



US 20040054272A1

(19) **United States**

(12) **Patent Application Publication**
Messing

(10) **Pub. No.: US 2004/0054272 A1**

(43) **Pub. Date: Mar. 18, 2004**

(54) **CATHETER WITH AN IRRIGATED
COMPOSITE TIP ELECTRODE**

Publication Classification

(75) Inventor: **Katie Messing**, San Jose, CA (US)

(51) **Int. Cl.⁷** **A61B 5/04; A61B 18/14**

(52) **U.S. Cl.** **600/374; 606/41**

Correspondence Address:

Bingham McCutchen, LLP

Suite 1800

Three Embarcadero

San Francisco, CA 94111-4067 (US)

(57) **ABSTRACT**

(73) Assignee: **Scimed Life Systems, Inc.**

(21) Appl. No.: **10/641,776**

(22) Filed: **Aug. 14, 2003**

Various catheter designs with irrigated tip electrodes are provided for reducing the heating of the tip resulting from RF biasing. The electrode tip of the catheter may be comprised of a highly thermal conductivity layer covered by a biologically compatible material and having irrigation or irrigation channels for removing excess thermal energy from the catheter tip and the surrounding area of the catheter tip. The catheter tip may be designed with multiple irrigation channels, multiple channel pathways, and/or exterior shapes to improve the cooling of the tip. These approaches may be used individually or in combination to produce a catheter tip with improved heat dissipation characteristics.

Related U.S. Application Data

(63) Continuation of application No. 09/896,730, filed on Jun. 28, 2001, now Pat. No. 6,611,699.

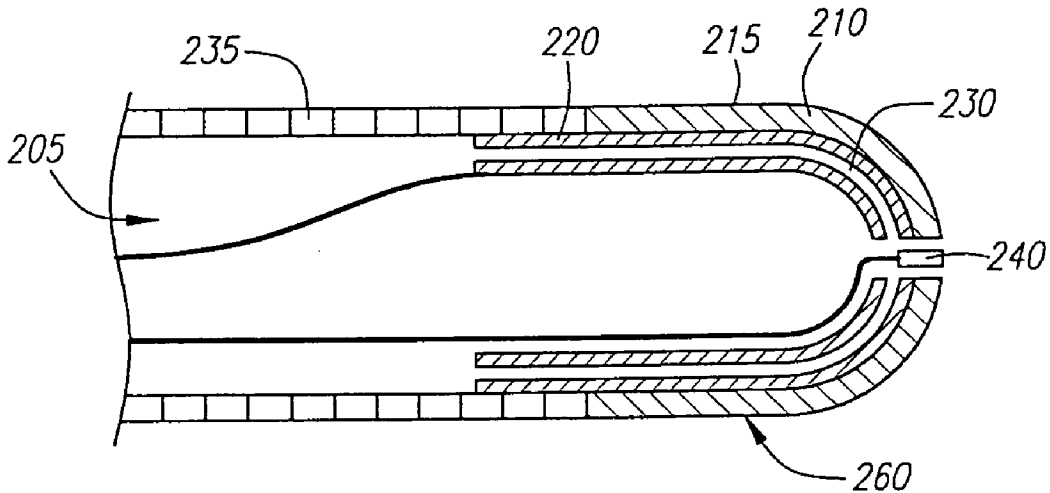

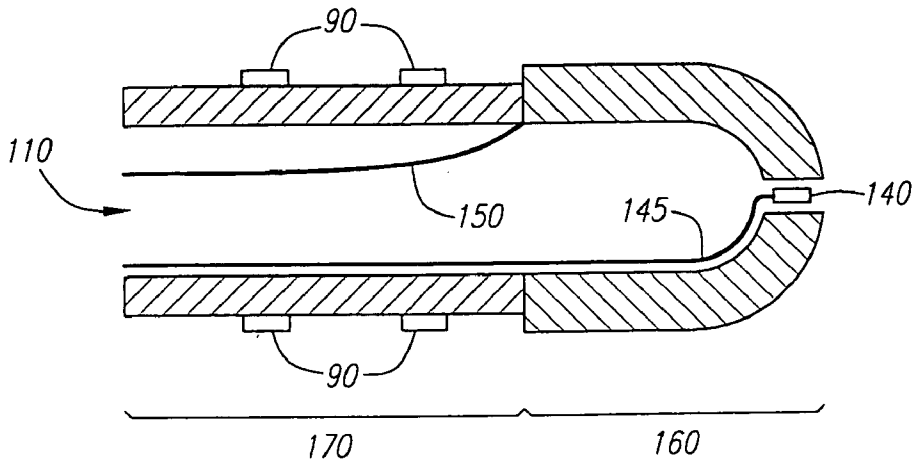

FIG. 1
(PRIOR ART)

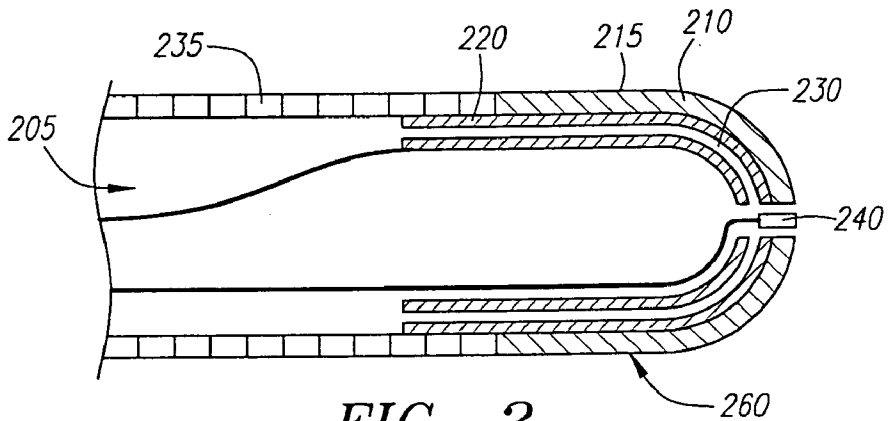

FIG. 2

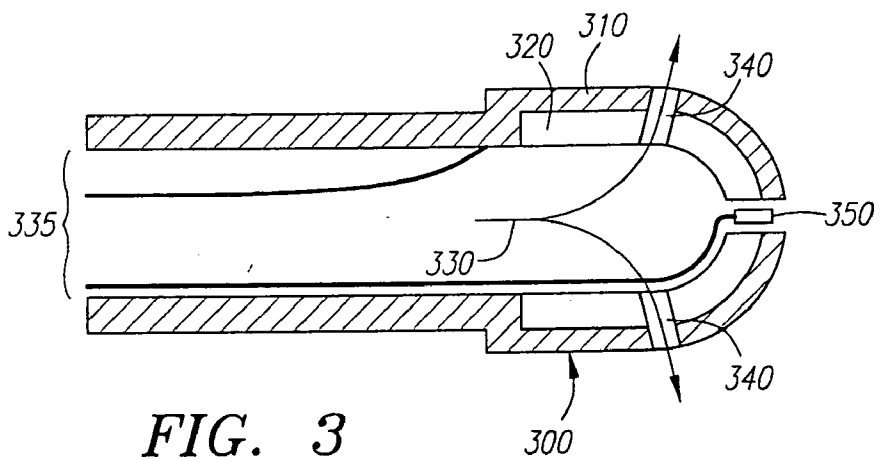

FIG. 3

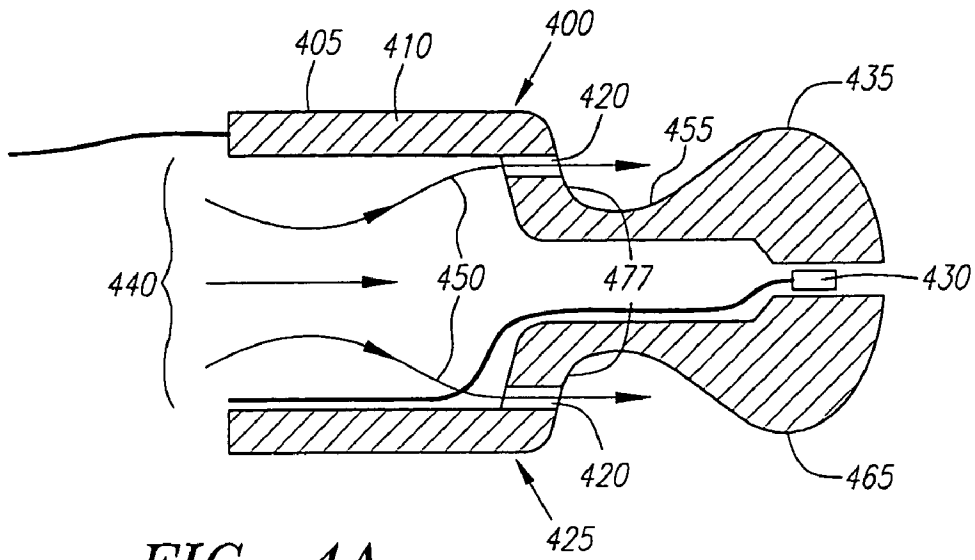

FIG. 4A

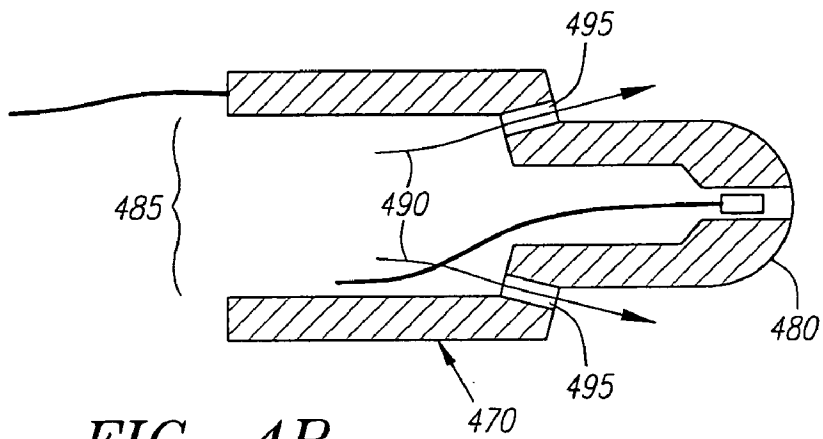

FIG. 4B

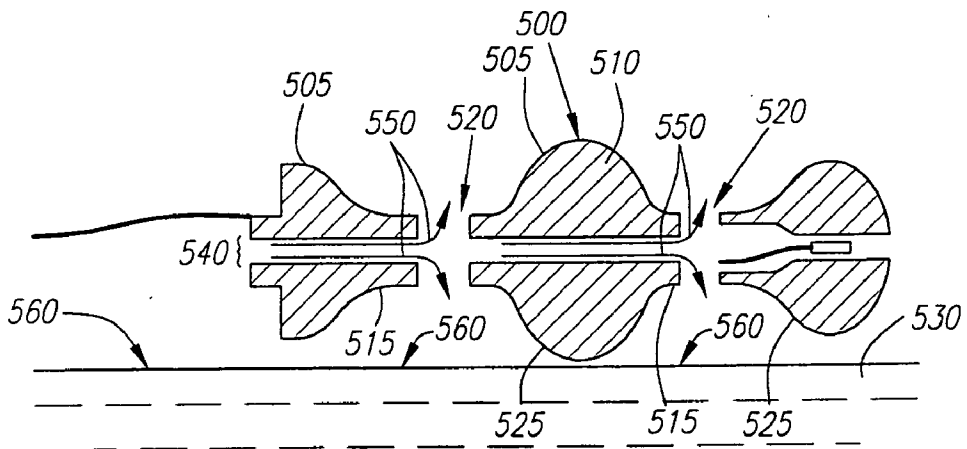

FIG. 5

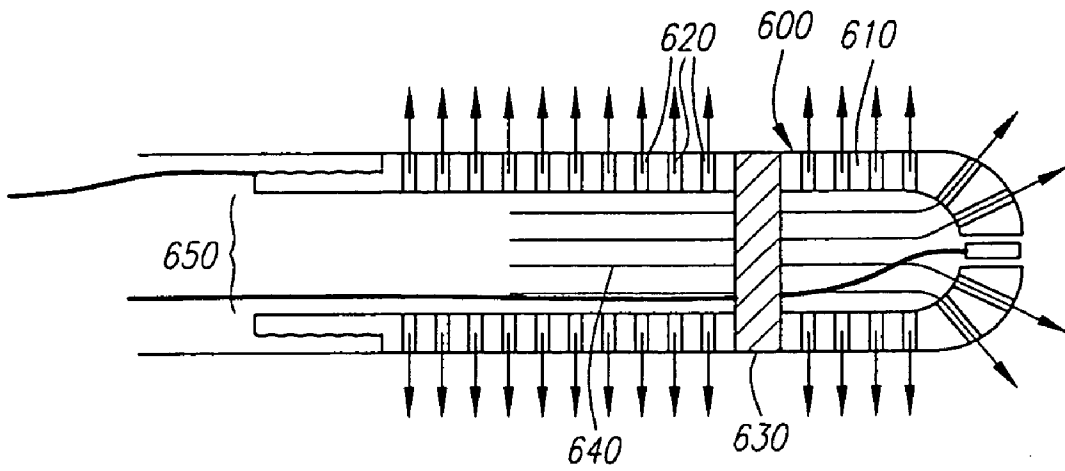

FIG. 6

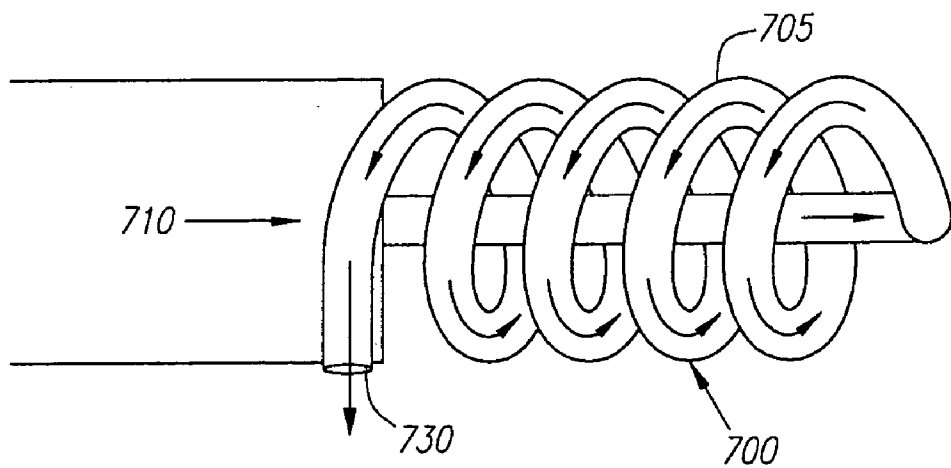

FIG. 7

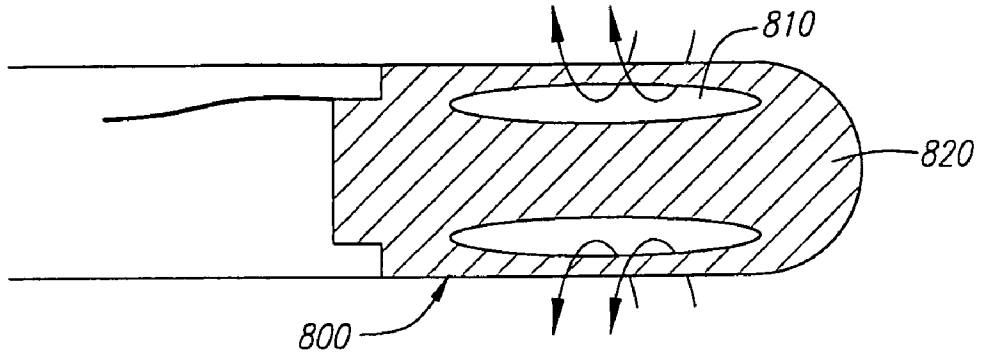

FIG. 8

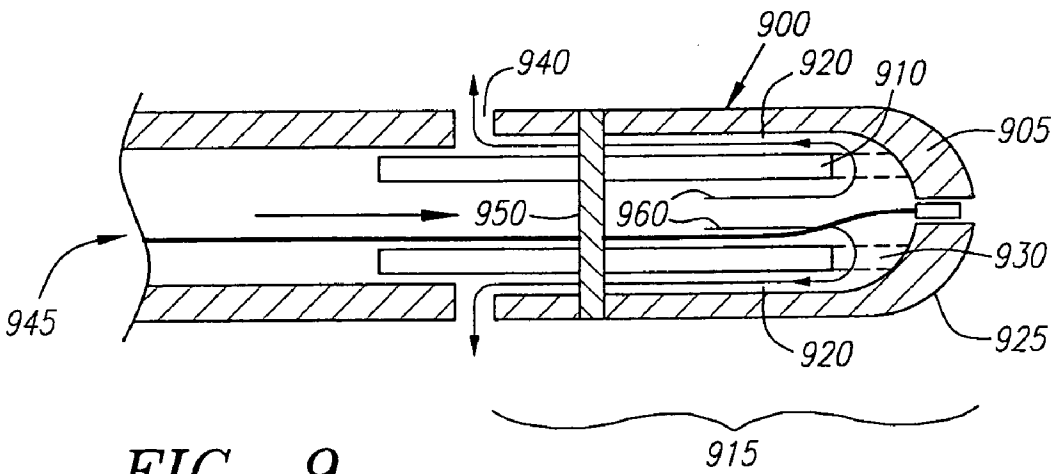

FIG. 9

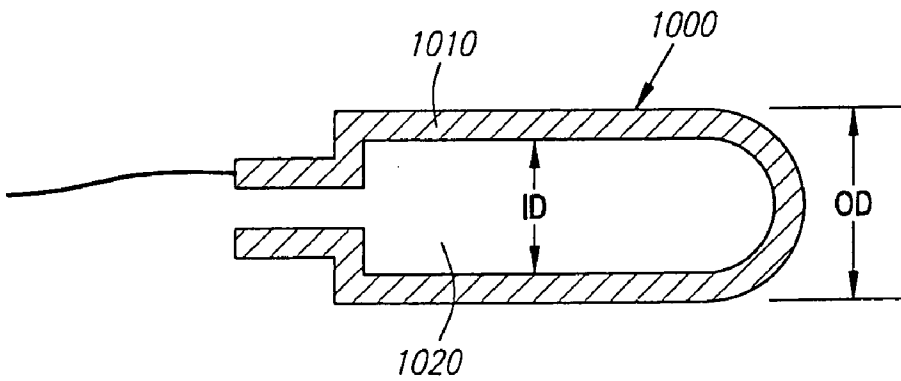

FIG. 10

CATHETER WITH AN IRRIGATED COMPOSITE TIP ELECTRODE

TECHNICAL FIELD

[0001] The present invention generally relates to catheters. More specifically, the present invention relates to an improved catheter that may be used in mapping and ablation procedures of biological tissues.

BACKGROUND OF THE INVENTION

[0002] For many years, catheters have had widespread application in the medical field. For example, mapping and ablation catheters have been extensively used in the treatment of cardiac arrhythmia. Cardiac arrhythmia treatments help restore the normal operation of the heart in pumping blood to the body. Mapping and ablation catheters play a critical role in these highly delicate treatments.

[0003] Typically, the catheters used in mapping and ablation procedures are steerable electrophysiological (“EP”) catheters that may be precisely positioned anywhere in the heart. These catheters are generally used during two distinct phases of treatment for heart arrhythmia. In one phase of treatment, the catheters are used to map the heart by locating damaged tissue cells. This involves the locating of damaged cells by steering the catheter to selected locations throughout the heart and detecting irregularities in the propagation of electrical wave impulses during contraction of the heart (a procedure commonly referred to as “mapping”). During the other phase of treatment, the same catheters are typically used to create scarring lesions at the location where damaged cells have been found (a procedure commonly referred to as “ablation”).

[0004] Ablation procedures using EP catheters are typically performed using radio frequency (“RF”) energy. In this regard, an EP catheter has one or more ablation electrodes located at its distal end. The physician directs energy from the electrode through myocardial tissue either to an indifferent electrode, such as a large electrode placed on the chest of the patient (in a uni-polar electrode arrangement), or to an adjacent electrode (in a bipolar electrode arrangement) to ablate the tissue. Once a certain temperature has been attained, resistance heating of the tissue located adjacent the one or more electrodes occurs, producing lesions at the targeted tissue.

[0005] Referring to FIG. 1, a conventional catheter that may be used in mapping and ablation procedures is provided. FIG. 1 shows the distal end of a catheter. The catheter distal end comprises a body member 170, for example, a plastic tubing, and an electrode tip 160, attached to the distal end of the body member 170. A RF wire 150 runs through an irrigation channel 110, or alternatively through a separate lumen formed within the body member 170, and is connected to the electrode tip 160. At the distal end of the electrode tip 160 is a sensor 140, for example, a thermistor or a thermocouple, which is in thermal contact with the electrode tip 160. A sensor wire 145 extends from the sensor 140 back through the irrigation channel 110, or alternatively through a separate lumen formed within the body member 170. Ring electrodes 90 may be mounted around the body member 170. The electrode tip 160 is used to provide RF energy to heart tissues during ablation procedures. The RF wire connects the electrode tip 160 to a RF power supply

(not shown). The ring electrodes 90 may be used together with the electrode tip 160 for mapping procedures.

[0006] Conventional catheters, such as those used for mapping and ablation procedures, are typically made entirely from a biologically compatible material, for example, a platinum iridium alloy (90 percent/10 percent). In general, however, the thermal conductivity of a platinum iridium alloy is not as high as that of other materials, such as copper or gold. One possible approach to increasing the thermal conductivity of an electrode is to form it from a material that is both biologically compatible and highly thermally conductive. However, many materials that are both biologically compatible and have highly thermal conductivity characteristics, such as gold, tend to be expensive.

[0007] As a result, catheter tips made entirely from economically feasible materials may be inefficient at dissipating excess thermal energy, thus creating thermal issues. Specifically, when excessive thermal energy is applied to a catheter electrode during ablation procedures, blood protein and other biological tissue may coagulate on the electrode, creating an embolic hazard. Such build up of coagulant on the electrode also hinders the transmission of RF energy from the electrode into the target tissue, thereby reducing the effectiveness of the ablation procedure. Ideally, it would be preferable to be able to focus the RF energy entirely on the targeted heart tissues without damaging the surrounding tissues or blood cells. That is, it would be highly preferable to be able to generate a good size lesion at a specifically defined area without altering, damaging, or destroying other surrounding tissue or blood.

[0008] In addition, it is generally desirable to be able to minimize the amount of time it takes to complete an ablation procedure. Typically, the longer it takes to complete an ablation procedure, the greater the health risk to the patient. Unfortunately, the time it takes to perform an ablation procedure may be related to how much thermal energy is directed towards the targeted tissue. That is, the greater the thermal energy directed towards the targeted tissue, the quicker the procedure can be performed. However, the amount of thermal energy that may be applied to the targeted tissue may be limited by damage that may potentially occur to the surrounding blood cells and tissues at highly thermal energy levels. For the above reasons, an EP catheter that is able to efficiently dissipate excess heat would be highly desirable.

SUMMARY OF THE INVENTION

[0009] The present inventions are directed to medical ablation electrodes that are capable of more efficiently dissipating heat during an ablation procedure.

[0010] In accordance with a first aspect of the present inventions, a medical ablation electrode comprises a biologically compatible outer layer, e.g., platinum iridium alloy, and a thermally conductive inner layer, e.g., copper. An irrigation channel is in contact with the inner layer for channeling cooling fluid. Preferably, the inner layer is in contact with the outer layer, e.g., by plating the outer layer onto the inner layer. In this manner, the conductive inner layer provides a highly conductive medium for increased heat dissipation from the electrode surface and its surrounding space, to an irrigating fluid flowing through the irrigation

channel. The irrigating fluid then quickly removes the heat from the electrode during a heating operation, for example, during ablation.

[0011] In accordance with a second aspect of the present inventions, a medical ablation electrode comprises a thermally conductive proximal section having a substantially distally facing wall, and an irrigation channel formed within the proximal section for channeling cooling fluid. The electrode further comprises a thermally conductive distal section and one or more irrigation exit ports that extend through the distally facing wall of the proximal section. Thus, when cooling fluid is conveyed through the irrigation channel, it flows out through the exit ports over the exterior surface of the distal section, dissipating heat from the electrode.

[0012] In accordance with a third aspect of the present inventions, a medical ablation electrode comprises a thermally conductive housing having one or more concave sections and one or more convex sections, an irrigation channel formed within the housing for channeling cooling fluid, and one or more irrigation exit ports adjacent the one or more concave sections of the housing. In this manner, cooling regions are provided between the concave sections and the tissue to be ablated during the ablation process, whereby cooling fluid conveyed out of the exit ports from the irrigation channel enters the cooling areas to cool the tissue.

[0013] In accordance with a fourth aspect of the present inventions, a medical ablation electrode comprises a spiral-shaped thermally conductive irrigation tube having an irrigation channel. In this manner, the area of the irrigation channel exposed to the cooling fluid is maximized. In this case, the housing may form a single unitary structure that can be composed essentially of a biologically compatible material, which otherwise may not be feasible absent the additional cooling of the electrode.

[0014] In accordance with a fifth aspect of the present inventions, a medical ablation electrode comprises a thermally conductive rigid housing and one or more flow-through channels formed by an external surface of the rigid housing for channeling biological fluids over the external surface. As a result, the external surface of the rigid housing is increased by use of the flow-through channels.

[0015] In accordance with a sixth aspect of the present inventions, a medical ablation electrode comprises an inner cylinder having an inner irrigation channel extending there-through for channeling cooling fluid. The electrode further comprises an outer cap that is mounted in a concentrically overlapping arrangement with the inner cylinder, such that an annular irrigation channel is formed between an inner surface of the outer cap and an outer surface of the inner cylinder for channeling the cooling fluid. In this manner, the cooling fluid flows over the inner and outer surfaces of the inner cylinder, thereby maximizing thermal dissipation of the heat into the cooling fluid. In a preferred embodiment, the inner cylinder and outer cap are composed of a thermally conductive biologically compatible material, and are mounted to each other using a pin. The electrode can further include one or more irrigation exit ports that are in fluid communication with the annular irrigation channel.

[0016] In accordance with a seventh aspect of the present inventions, a medical ablation electrode comprises a ther-

mally conductive housing, and an irrigation channel formed in the housing for channeling cooling fluid. The housing in thin-walled, i.e., the wall of the housing has a thickness that is less than the diameter of the irrigation channel divided by the number 2. In this manner, the heat transfer rate through the housing wall is increased, thereby increasing the amount of thermal energy dissipated into the cooling fluid.

[0017] Thus, as can be seen, that in accordance with the second through seventh aspects of the present inventions, the electrode structure can be composed essentially of a biologically compatible material, which otherwise may not be feasible absent the additional cooling of the electrode and/or tissue. Alternatively, however, the housing can be composed of a highly thermally conductive inner layer and biologically compatible outer layer, or can be composed purely of a highly thermally conductive, but biologically compatible material, such as gold, to further increase the cooling of the electrode.

BRIEF DESCRIPTION OF THE DRAWINGS

[0018] FIG. 1 is a cross-sectional view of a conventional catheter tip electrode used for mapping and ablation procedures.

[0019] FIG. 2 is a cross-sectional view of an internally irrigated catheter tip electrode comprising a biologically compatible outer layer and a thermally conductive inner layer.

[0020] FIG. 3 is a cross-sectional view of a flushing irrigating catheter tip electrode comprising a biologically compatible outer layer and a thermally conductive inner layer.

[0021] FIGS. 4A and 4B are cross-sectional views of self-cooling catheter tip electrodes, wherein the external surfaces of the electrodes are cooled by irrigation exit ports.

[0022] FIG. 5 is a cross-sectional view of a tissue-cooling catheter tip electrode, wherein the external surface comprises concave regions with irrigation exit ports for cooling surrounding tissue.

[0023] FIG. 6 is a cross-sectional view of a tissue-cooling catheter tip electrode comprising multiple irrigation exit ports.

[0024] FIG. 7 is a side view of a spiral shaped catheter tip electrode.

[0025] FIG. 8 is a cross-sectional view of a catheter tip electrode with flow-through channels.

[0026] FIG. 9 is a cross-sectional view of a catheter tip electrode with an outer cap and an inner cylinder forming an annular irrigation channel therebetween.

[0027] FIG. 10 is a cross-sectional view of a "thin-walled" catheter tip electrode.

DESCRIPTION OF THE PREFERRED EMBODIMENTS

[0028] The present invention is directed towards a catheter device having a biologically compatible irrigated tip electrode. Such catheters may be used in, for example, mapping and ablation procedures of the human heart.

[0029] In a preferred embodiment of the present invention a catheter with an efficiently cooled tip is provided. Efficient cooling of a catheter tip electrode is achieved by combining two techniques for improving the cooling efficiency of the electrode. First, the electrode is constructed using components that have highly thermal conductivity and are compatible with biological fluids and tissues. Specifically, the electrode is composed of components that are made from highly conductive but non-biologically compatible materials that are encased or covered with a layer of biologically compatible material, e.g., a composite tip. By using highly thermal conductivity materials to construct the electrode, the thermal energy that may build up on the surface of the electrode and the surrounding area (where blood and tissue may be present) may be quickly dissipated. The electrode is also irrigated such that the heat present at the tip is quickly and efficiently carried away from the tip (two exemplary ways to irrigate an electrode will be discussed below—"internal irrigation" and "flushing irrigation").

[0030] Referring now to FIG. 2, one embodiment of a catheter incorporating the principles of the present invention is illustrated. The catheter is shown comprising a catheter tip electrode 260 that includes a biologically compatible outer layer 210 and a highly thermal conductivity inner layer 220. A temperature sensor 240, for example, a thermistor or a thermocouple, may be located at the distal end of the electrode 260. Other sensors, such as a 3D sensor (not shown), may also be placed at the distal end of the electrode 260. The biologically compatible outer layer 210 may be, for example, 90 percent platinum/10 percent iridium alloy. The outer layer 210 may, of course, be made from biologically compatible material other than a platinum iridium alloy. For example, gold and gold alloys, platinum and platinum alloys, titanium, tungsten, stainless steel, etc. may also be used for the outer layer. The highly thermal conductivity inner layer 220 may be, for example, pure copper, silver, or a copper or silver alloy. Other highly thermal conductivity materials other than copper or silver may be used for the inner layer. The proximal end of the inner layer 220 is exposed, such that the distal end of a catheter tube 235 can be bonded thereto.

[0031] The outer layer 210 may be thin, for example, in the range of microns, and may be placed over the inner layer 220 by, for example, plating techniques. Alternative methods of forming the tip may also be used. Preferably, the technique provides a good thermal and electrical connection between the outer layer 210 and inner layer 220. Details on general composite catheter tip electrodes are disclosed in U.S. Pat. No. 6,099,524 issued to Lipson et al., which is hereby expressly incorporated by reference as if fully set forth herein.

[0032] For purposes of irrigation, an irrigation channel 230 runs through the inner layer 220 to provide a flow path for irrigating fluids such as saline. The irrigation channel 230 is in fluid communication with an irrigation lumen 205, which extends proximally through the catheter tube 235 to a suitable pump (not shown). The irrigation channel 230 can be formed using any suitable method, such as machining or wax molding. As the irrigating fluid flows through the irrigation channel 230, it removes the heat being dissipated by the inner layer 220. For example, when the catheter of FIG. 2 is used in ablation procedures, excess heat may build up at the outer layer surface 215 and in the surrounding

space (which may include blood and tissue). The excess heat will readily transfer through the highly conductive inner layer 220 and dissipate into the irrigating fluid flowing through the irrigation channel 230. The temperature and flow rate of the irrigating fluid can be of any suitable value, e.g., in the range of 30° C.-33° C., or alternatively room temperature, and 30-40 cc/min, or even lower, respectively.

[0033] By using an electrode with a core material (e.g., inner layer 220) that has highly thermal conductivity, several advantages may be realized. For example, the use of a highly conductive inner (core) material may result in a more efficient dissipation of heat energy, thus requiring a lower flow rate for the irrigating fluid. A lower flow rate would benefit the system because lower pump pressure would be required. This may thus lower the cost of the fluid pump, which is used to set the flow rate. A low flow rate decreases the chance of catheter failure due to lower pressure, thus making the catheter more safe for the patient. Also, because of improved heat dissipation, an irrigation fluid having higher temperature may be used. This will eliminate or reduce the need to cool the irrigation fluid temperature. For example, under the same power settings during ablation, the flow rate of the irrigating fluid may be lower than a tip made from a less conductive biologically compatible material. Furthermore, the present invention provides an irrigated catheter that delivers more power to the targeted tissue during ablation procedure without the need for increasing the flow rate of the irrigating fluid, thereby improving its efficiency at producing lesions.

[0034] The method of cooling the electrode 260 with an internal irrigation channel illustrated in FIG. 2 is commonly referred to as "internal irrigation". In internal irrigation, the irrigating fluid will not exit the electrode 260 and flow out of the catheter. Instead, the irrigating fluid stays completely within the catheter and is typically re-circulated. Thus, the same fluid may be used over and over again to cool the electrode 260.

[0035] Referring now to FIG. 3, another embodiment of the present invention is illustrated. In FIG. 3, a catheter is shown with a "flushing irrigation" catheter tip electrode 300 comprising a biologically compatible outer layer 310 and a thermally conductive inner layer 320 similar to the catheter tip electrode of FIG. 2. Unlike the electrode of FIG. 2, however, no irrigation channel runs through the inner layer 320. Rather, the irrigation fluid flows through an irrigation channel 335 formed by the inner surface of the inner layer 320 (where the RF wire and steering mechanism is typically situated) and exit out of exit ports 340, which extend through both the inner layer 320 and outer layer 310. Thus, the exit ports 340 provide an exit for the irrigation fluid flowing through the irrigation channel 335 via flow path 330. Again, a sensor 350, such as a thermistor, may be located at the distal end of the tip and the irrigation channel 335 may contain a 3D sensor (not shown).

[0036] Preferably, the walls of the irrigation channel 335 and/or exit ports 340 are covered by a layer of biologically compatible material, to ensure that there will be no adverse interaction between the highly conductive inner layer 320 (which is not biocompatible) and the cooling fluid, as well as any biological fluids and/or tissues, present in the irrigation channel 335 and exit ports 340.

[0037] The present invention, as embodied in FIG. 3, allows the excess heat in the outer layer 310 and in the

outside space (which typically comprises of blood and tissue) immediately adjacent to the outer layer **310**, to be dissipated through the inner layer **320** and into the irrigating fluid as it flows through the irrigation channel **335** and exits the exit ports **340**. Upon exiting the exit ports **340**, the irrigating fluid will mix with the body fluid (e.g., blood) in the surrounding outside space.

[0038] The electrode **300** described in **FIG. 3** is one type of “flushing irrigation” catheter and is commonly referred to as a “showerhead” catheter tip electrode. The highly thermal conductivity inner layer **320** again has the benefits as described in reference to the embodiment of **FIG. 2**. In this case it is further advantageous for the patient, since the inner layer **320** allows the use of less irrigating fluid, thereby minimizing the fluid that enters the patient’s body.

[0039] Other showerhead tip designs are also contemplated by the present invention and are described below. Referring to **FIG. 4A**, a catheter tip electrode **425** that “cools itself” is provided. The electrode **425** comprises a housing **410** composed essentially of a biologically compatible material, such as a platinum-iridium alloy. Alternatively, the housing **410** can be formed of a highly thermally conductive inner layer and a biologically compatible outer layer, much like the electrodes shown in **FIGS. 2 and 3**. Of course, the housing **410** may also be formed of both a highly conductive and biologically compatible (e.g., gold), in which case there would be no need to cover such a material with a biologically compatible material.

[0040] The housing **410** comprises a proximal section **405** and a distal section **435**. The proximal section **405** comprises an irrigation channel **440** and a distally facing surface **455**. The distal section **435** is mushroom-shaped, i.e., it comprises a neck **455** and head **465**. The electrode **400** comprises irrigation exit ports **420**, which extend through the distally facing surface **455** of the proximal section **405**. Thus, an irrigating fluid, for example, a saline solution, flows through the irrigation channel **440** via flow path **450** and exits the electrode **400** through exit ports **420** proximal the distal end **435**. As the irrigating fluid flows through the irrigation channel **440**, the irrigating fluid takes away the thermal energy being dissipated from the housing **410**. As the irrigating fluid exits the electrode **400** it is directed to flow over the head **465** of the distal section **435** to “cool itself.” At the distal end of the electrode **400** is a sensor **430**, for example, a thermistor or a thermocouple, which is in thermal contact with the electrode tip **160**.

[0041] Alternatively, a catheter tip electrode **470** may be shaped such that a distal section **480** is straight rather than mushroom-shaped, as illustrated in **FIG. 4B**. The electrode **470** comprises a proximal section **475** with an irrigation channel **485** and a substantially distally facing surface **477**. Thus, an irrigating fluid, for example, a saline solution, flows through an irrigation channel **485** via flow path **490** and exits the electrode **470** through exit ports **495** extending through the distally facing surface **477** proximal the distal end **480**. As the irrigating fluid exits the electrode **470**, it is directed to flow over the straight distal end **480** to “cool itself.”

[0042] Referring now to **FIG. 5**, a catheter tip electrode **500** that “cools the surrounding tissue” is provided. This is achieved by forming the electrode **500** with an undulating outer surface **505**, i.e., alternating between convex sections

525 and concave sections **515**. The electrode **500** comprises a housing **510** composed essentially of a biologically compatible material, such as a platinum-iridium alloy. Alternatively, the housing **510** can be formed of a highly thermally conductive inner layer and a biologically compatible outer layer, much like the electrodes shown in **FIGS. 2 and 3**. Of course, the housing **510** may also be formed of both a highly conductive and biologically compatible (e.g., gold), in which case there would be no need to cover such a material with a biologically compatible material.

[0043] In any case, the irrigating fluid flows through the irrigation channel **540** via flow paths **550** and exits the electrode **500** through exit ports **520** in the concave sections **515** of the tip housing **510**. As the irrigating fluid exits the electrode **500** it cools the surrounding tissues **530**, e.g., at cooling areas **560**. Thus, cooling fluid that may otherwise be blocked by direct tissue contact when using a level irrigated catheter tip, is delivered to the pertinent tissue substantially unimpeded.

[0044] Referring to **FIG. 6**, another catheter tip electrode **600** comprises a housing **610** made of a non-conductive material, e.g., plastic, that preferably withstand tissue temperatures without deforming. The housing **610** comprises a large number of irrigation exit ports **620** to provide sufficient cooling. Of course, the tip housing **610** may comprise a composite tip with a highly thermal conductive core (e.g., inner layer) covered by a biological compatible material. This tip housing **610** design, however, may be comprised entirely of biologically compatible material, since sufficient cooling is obtained through the use of a plethora of exit ports **620** in the housing **610**. That is, an irrigating fluid flows through the irrigation channel **650** via flow paths **640** and exits the catheter through the exit ports **620** in the housing **610**. The large number of exit ports **620** allows for reduced irrigation fluid flow and higher irrigation fluid temperature. This embodiment may also include a ring electrode **630** disposed around the housing **610**, so that mapping may occur. Using this catheter tip design, the cooling liquid could be used as the source of RF energy that is applied to the tissue during ablation procedures.

[0045] Referring to **FIG. 7**, a catheter tip electrode **700** comprises a spiral shape irrigation tube **705** composed essentially of biologically compatible material, such as a platinum-iridium alloy. Alternatively, the irrigation tube **705** can be formed of a highly thermally conductive inner layer and a biologically compatible outer layer, much like the electrodes shown in **FIGS. 2 and 3**. Of course, the irrigation tube **705** may also be formed of both a highly conductive and biologically compatible (e.g., gold), in which case there would be no need to cover such a material with a biologically compatible material.

[0046] The irrigating fluid flows through a passage **710** in the spiral irrigation tube **705** and exits the electrode **700** out through exit port **730**, thereby cooling the inner surface of the tube **705**. The wall of the spiral irrigation tube **705** is thin, thereby allowing the cooling fluid to run along a path closer to the surface of the electrode **700**, causing greater cooling than an electrode cooled more towards the inner part thereof. Thus, the spherical design of this embodiment provides a larger cooling surface area resulting in improved cooling efficiency.

[0047] Although in **FIG. 7** the irrigating fluid is shown to be exiting through the outlet **730**, the fluid does not have to

exit the electrode **700**. Rather, the cooling fluid may be re-circulated by directing the outlet **730** back through the catheter tubing to a pump. That is, the electrode **700** may be configured as an internally irrigated tip. Further, the shape of the spiral may vary (e.g., spacing between loops) and the cross-section of the hollow channel can also vary (e.g., circular, oval, etc.). Referring to **FIG. 8**, another embodiment having a catheter design with improved catheter tip cooling will be described. In this design, an electrode **800** comprises a tip housing **820** with "flow through" channels **810**. Unlike the previously disclosed electrode designs, the flow through channels **810** of the catheter in **FIG. 8** are not connected to an internal irrigation channel, but rather is a through channel for the external fluids (e.g., blood) to flow through. As such, the electrode cooling is accomplished in a first instance by the natural circulation of the surrounding fluid (i.e., blood). Alternatively, this embodiment could be combined with one or more of the other embodiments for even more enhanced tip cooling by internally circulating an irrigating fluid. For example, the tip housing **820** may comprise a thermally conductive core covered by a biological compatible material (not shown), such that the thermally conductive core is not in direct contact with the surrounding biological liquid and/or tissue. Of course, if the conductive core is biologically compatible, a biologically compatible material need not be used to cover the core. In any case, the electrode **800** is designed such that the through channels (or passageways) increase the surface area of the electrode **800**, allowing for quicker cooling.

[**0048**] Referring now to **FIG. 9**, yet another embodiment for an improved cooling of a catheter tip electrode **900** is provided. In this design, the irrigating fluid exits from an exit port **940**, which is located at the proximal end of the electrode **900**, rather than through exit ports located at the distal end. The electrode **900** comprises an inner cylinder and a concentrically overlapping outer cap **905**, which are attached together by a pin **950** that extends laterally there-through. Thus, an annular entry port **930** is formed between a distal end **925** of the outer cap **905** and the distal end of the inner cylinder **910**, and an annular channel **920**, which is in fluid communication with the annular channel **920**, is formed between the inner surface of the outer cap **905** and the outer surface of the inner cylinder **910**. It should be noted that the outer cap **905** and inner cylinder **910** may overlap anywhere in region **915**, such that the channel **920** is formed. Following flow path **960**, the irrigating fluid enters the electrode **900** from a proximal irrigation channel **945** within the inner cylinder **910** and flows towards the distal end **925** of the outer cap **905**, where it enters into the annular entry port **930**, through the annular channel **920**, and out the exit ports **940**. As a result, the electrode **900** is cooled.

[**0049**] The outer cap **905** is composed essentially of biologically compatible material, such as a platinum-iridium alloy. Alternatively, the outer cap **905** is formed of a highly thermally conductive inner layer and a biologically compatible outer layer, much like the electrodes shown in **FIGS. 2 and 3**. Of course, the outer cap **905** may also be formed of both a highly conductive and biologically compatible (e.g., gold), in which case there would be no need to cover such a material with a biologically compatible material.

[**0050**] Referring to **FIG. 10**, yet another embodiment for an improved cooled catheter tip electrode **1000** is shown. In this design, the walls of the electrode **1000** are thinned to

improve the cooling rate of the electrode during irrigated procedures. The electrode **1000** includes a housing **1010** having an irrigation channel **1020**. The housing **1010** has an inner diameter (ID) defined by its inner surface, and an outer diameter (OD) defined by its outer surface. Thus, the wall thickness of the housing **1010** can be defined as $t=(OD-ID)/2$. In the preferred embodiment, the wall of the housing **1010** is considered "thin-walled," which for the purposes of this specification is an ablation electrode, each wall of which exhibits a thickness t that is less than $ID/2$. Preferably the wall thickness t of the housing **1010** is less than $ID/4$ and more preferably less than $ID/10$. Thus, the cooling effects of irrigating fluid flowing through the electrode **1000** will be greater than that for electrodes that are not "thin-walled."

[**0051**] Specifically, the heat rate of conduction through a cylindrical wall can be described by the following equation: $q=(2\pi Lk*\Delta T)(\ln(r_2/r_1))$, where L =length, k =thermal conductivity, ΔT =difference in temperature across the wall of the cylinder, $r_1=ID/2$, and $r_2=OD/2$. In comparing the heat rate of conduction between a conventional electrode, which typically has an ID and OD of 0.050 and 0.105 inches, respectively (i.e., $r_1=0.025$ " and $r_2=0.0525$ "") with exemplary ID and OD values of the electrode **1000** of 0.08750 and 0.105 inches, respectively (i.e., $r_1=0.04375$ " and $r_2=0.0525$ "), the increase in heat rate between the conventional electrode and the electrode **1000** (equal to $[1/\ln(r_2/r_1)]_{new}/\ln(r_2/r_1)_{conv}$) is 4.069 greater. As a result, the electrode **1000** is capable of producing larger volume lesion than conventional electrodes.

[**0052**] Although particular embodiments of the present invention have been shown and described, it will be understood that it is not intended to limit the invention to the preferred embodiments and it will be obvious to those skilled in the art that various changes and modifications may be made without departing from the spirit and scope of the present invention. Thus, the invention is intended to cover alternatives, modifications, and equivalents, which may be included within the spirit and scope of the invention as defined by the claims.

What is claimed is:

1. A medical ablation electrode, comprising:
 - a biologically compatible outer layer;
 - a thermally conductive inner layer; and
 - an irrigation channel in contact with said inner layer for channeling cooling fluid.
2. The electrode of claim 1, wherein said outer layer is platinum iridium alloy.
3. The electrode of claim 2, wherein said platinum iridium alloy is composed of approximately 90 percent platinum and 10 percent iridium.
4. The electrode of claim 3, wherein said inner layer is copper.
5. The electrode of claim 1, wherein said outer layer is plated onto said inner layer.
6. The electrode of claim 1, wherein said inner layer is in contact with said outer layer, whereby said inner layer dissipates heat from said outer layer to fluid flowing through said irrigation channel.
7. The electrode of claim 1, wherein said irrigation channel is formed through said inner layer.
8. The electrode of claim 1, wherein an inner surface of said inner layer forms said irrigation channel.

9. The electrode of claim 1, further comprising an irrigation exit port extending laterally through said inner and outer layers, said exit port being in fluid communication with said irrigation channel.

10. The electrode of claim 9, wherein said irrigation channel comprises a wall that is covered by a layer of a biologically compatible material.

11. The electrode of claim 1, further comprising a RF ablation wire electrically coupled to said inner layer.

12. A medical ablation electrode, comprising:

a thermally conductive proximal section having a substantially distally facing wall;

an irrigation channel formed within said proximal section for channeling cooling fluid;

a thermally conductive distal section having an exterior surface; and

one or more irrigation exit ports extending through said distally facing wall proximal to said distal section, whereby said cooling fluid is flowed over said exterior surface of said distal section when said cooling fluid is conveyed through said irrigation channel.

13. The electrode of claim 12, wherein said distal section comprises a neck and a head, said neck being mounted to said distally facing wall.

14. The electrode of claim 12, wherein said distal section has a substantially uniform diameter.

15. The electrode of claim 12, wherein said proximal and distal sections form a single unibody structure.

16. The electrode of claim 12, wherein said proximal and distal sections consist essentially of a biologically compatible material.

17. The electrode of claim 12, further comprising a RF wire electrically coupled to said proximal section.

18. A medical ablation electrode, comprising:

a thermally conductive housing having one or more concave sections and one or more convex sections;

an irrigation channel formed within said housing for channeling cooling fluid;

one or more irrigation exit ports adjacent said one or more concave sections of said housing, said one or more exit ports being in fluid communication with said irrigation channel.

19. The electrode of claim 18, wherein said one or more concave sections comprises a plurality of concave sections, and said one or more irrigation exit ports comprises a plurality of irrigation exit ports.

20. The electrode of claim 18, wherein said housing forms a unibody structure.

21. The electrode of claim 18, wherein said housing consists essentially of a biologically compatible material.

22. The electrode of claim 18, further comprising a RF wire electrically coupled to said housing.

23. A medical ablation electrode, comprising:

a thermally conductive irrigation tube having an irrigation channel for channeling cooling fluid, said irrigation tube having a spiral shape.

24. The electrode of claim 23, wherein said irrigation tube comprises an exit port.

25. The electrode of claim 23, wherein said irrigation tube consists essentially of a biologically compatible material.

26. The electrode of claim 23, further comprising a RF wire electrically coupled to said irrigation tube.

27. A medical ablation electrode, comprising:

a thermally conductive rigid housing; and

one or more flow-through channels formed by an external surface of said rigid housing for channeling biological fluids over said external surface adjacent said flow-through channels.

28. The electrode of claim 27, wherein said one or more flow-through channels extend laterally through said rigid housing.

29. The electrode of claim 27, wherein said rigid housing consists essentially of a biologically compatible material.

30. The electrode of claim 27, further comprising a RF wire electrically coupled to said rigid housing.

31. A medical ablation electrode, comprising:

an inner cylinder;

an inner irrigation channel extending through said inner cylinder for channeling cooling fluid;

an outer cap mounted in a concentrically overlapping arrangement with said inner cylinder, and

an annular irrigation channel formed between an inner surface of said outer cap and an outer surface of said inner cylinder for channeling said cooling fluid, wherein said annular irrigation channel is in fluid communication with said inner irrigation channel.

32. The electrode of claim 31, further comprising one or more irrigation exit ports in fluid communication with said annular irrigation channel.

33. The electrode of claim 31, further comprising a pin that extends through said inner cylinder and said outer cap for mounting said outer cap to said inner cylinder.

34. The electrode of claim 31, further comprising an annular entry port formed between a distal end of said outer cap and a distal end of said inner cylinder, wherein said entry port is in fluid communication with said inner irrigation channel.

35. The electrode of claim 31, wherein said inner cylinder and outer cap are composed of a thermally conductive material.

36. The electrode of claim 31, wherein said outer cap consists essentially of a biologically compatible material.

37. The electrode of claim 31, further comprising a RF ablation wire electrically coupled to said inner cylinder.

38. A medical ablation electrode, comprising:

a thermally conductive housing comprising a wall; and

an irrigation channel formed in said housing for channeling cooling fluid;

wherein said housing wall has a thickness that is less than a diameter of said irrigation channel divided by the number 2.

39. The electrode of claim 38, wherein said housing consists essentially of a biologically compatible material.

40. The electrode of claim 38, further comprising a RF ablation wire electrically coupled to said housing.

41. The electrode of claim 38, wherein said housing wall has a thickness that is less than a diameter of said irrigation channel divided by 4.

42. The electrode of claim 38, wherein said housing wall has a thickness that is less than a diameter of said irrigation channel divided by 10.

* * * * *