

Oct. 21, 1969

T. P. JAKUBOWSKI ET AL

3,473,253

BUBBLE BLOWING DEVICE

Filed Feb. 28, 1967

2 Sheets-Sheet 1

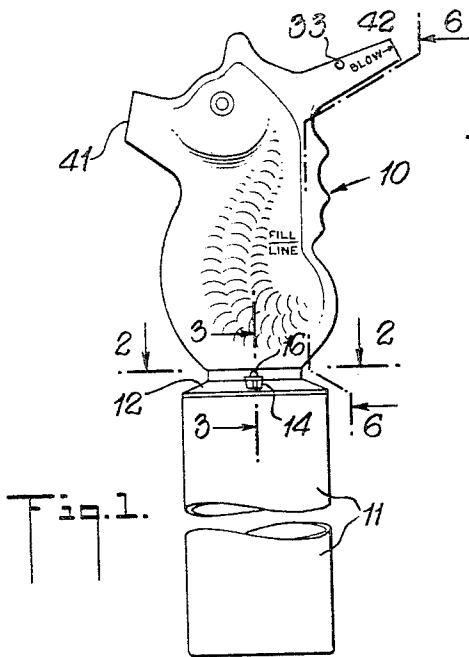

Fig. 2.

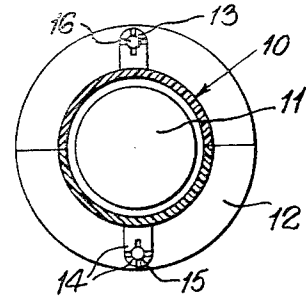

Fig. 3.

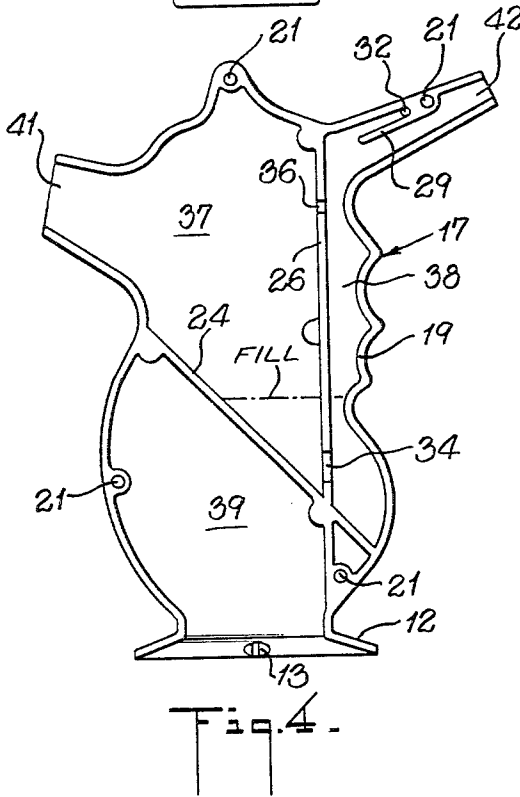
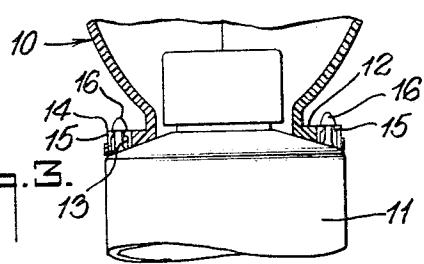

Fig. 4.

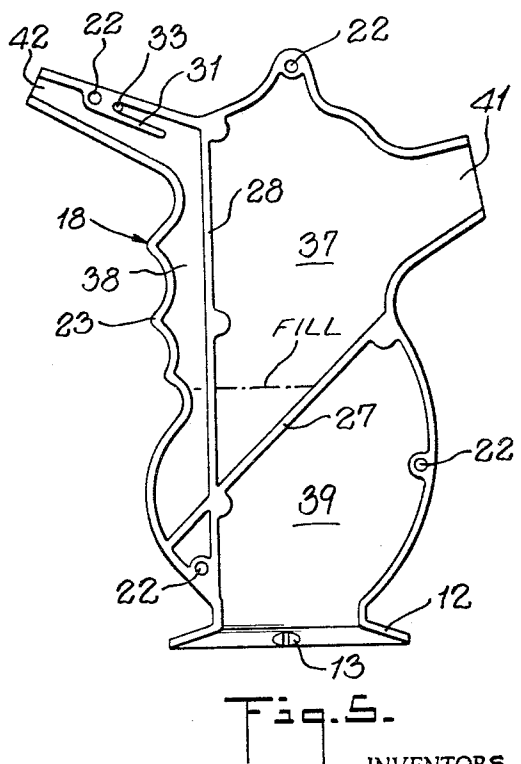

Fig. 5.

INVENTORS
 THEODORE P. JAKUBOWSKI
 KENNETH E. ANDREOTTA
 BY
Leo C. Krasinski
 ATTORNEY

Oct. 21, 1969

T. P. JAKUBOWSKI ET AL

3,473,253

BUBBLE BLOWING DEVICE

Filed Feb. 28, 1967

2 Sheets-Sheet 2

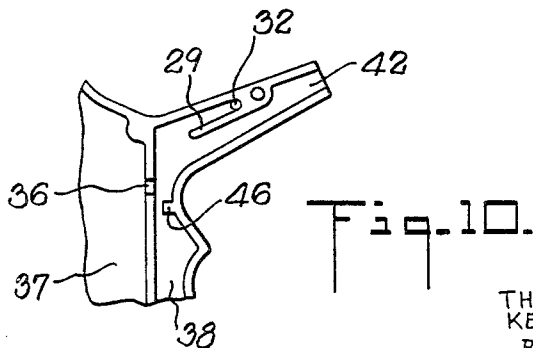
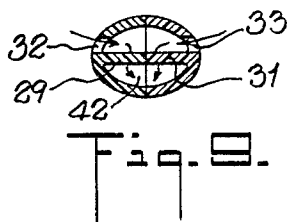
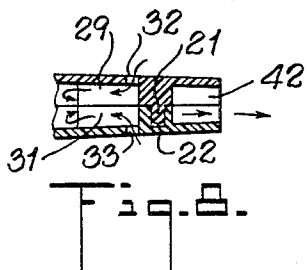
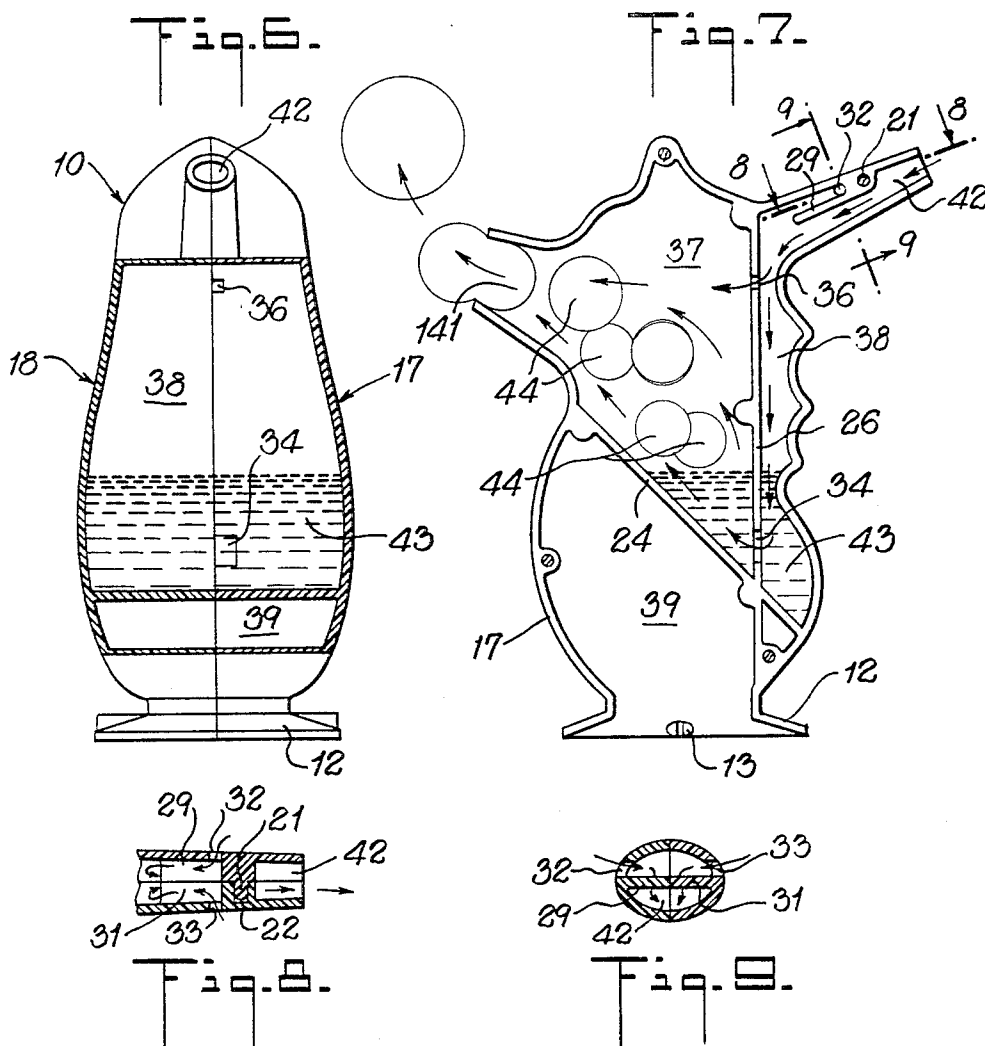

INVENTORS
THEODORE P. JAKUBOWSKI
KENNETH E. ANDREOTTA
BY
Leo C. Krazinski
ATTORNEY

1

2

3,473,253

BUBBLE BLOWING DEVICE

Theodore P. Jakubowski, Clifton, and Kenneth E. Andretta, Little Falls, N.J., assignors, by mesne assignments, to Theodore P. Jakubowski, Clifton, N.J.
 Filed Feb. 28, 1967, Ser. No. 618,807
 Int. Cl. A63h 33/28

U.S. Cl. 46—7

2 Claims

ABSTRACT OF THE DISCLOSURE

A bubble blowing device having a reservoir for a bubble forming solution with an air inlet passageway into the reservoir and with an exit passageway for emission of bubbles, wherein the air inlet passageway is provided with a safety vent above the reservoir for preventing aspiration of the solution and with a baffle for deflecting input air past said vent.

BACKGROUND OF THE INVENTION

Field of invention

The invention relates to soap bubble blowing devices having a reservoir for the solution and an air chamber thereabove with the bubbles being formed in the air chamber and blown therefrom into the atmosphere.

DESCRIPTION OF PRIOR ART

The instant invention is an improvement over the bubble blowing device of Patent No. 2,587,895. Patents representative of the bubble blowing art are Blair 1,124,204, Cohn 1,389,098, Evans 1,504,186, Bloxom 1,962,801 and Wister 2,711,612.

SUMMARY OF THE INVENTION

This invention relates to a device for blowing bubbles and has for its primary object to provide a simple and comparatively inexpensive toy particularly for children.

It is evident that many factors enter into the production of a practical bubble blowing device, such as the minimal number of parts required, the relationship between the volume of the reservoir containing the bubble forming solution and that of the air space above the reservoir in order to produce the desired bubble size, and especially the necessity for preventing inhalation by the child of any of the bubble forming solution.

It is accordingly another object of the invention to provide a readily assembled, two part moulded device for producing large enough bubbles wherein the child blowing the bubbles can inhale air without at the same time inhaling some of the bubble liquid, as in some of the prior art bubble devices.

It is a further object of the invention to provide an ornamental bubble blowing device which is attractive to children and which also includes the advantages features mentioned hereinbefore.

With the above objects in view, one embodiment of the invention discloses a hollow receptacle of ornamental design, such as a sea horse, having two substantially identical sections that are readily fitted together to form two useful compartments of the invention, one compartment including an entrance passageway and the other compartment a bubble forming chamber with an exit passageway, in which a reservoir for the bubble forming solution is provided in the lower portion of both compartments with an optimal air space thereabove for the formation of bubbles. A vertical wall separating both compartments includes two openings therethrough, one within the lower reservoir portion for blowing air through the solution to form the bubbles and the other opening at the upper por-

tion of the bubble forming chamber for blowing the formed bubbles out through the exit passageway into the atmosphere. The entrance passageway adjacent its upper end has a third opening as a safety vent for preventing aspiration of the bubble forming solution and a baffle for directing input air past the third opening.

BRIEF DESCRIPTION OF THE DRAWINGS

A more complete understanding of the invention will be obtained from the following description of a preferred embodiment thereof, taken in connection with the accompanying drawings, in which:

FIG. 1 is an elevational view of a bubble blowing device of the invention mounted upon a receptacle containing a supply of bubble forming solution;

FIGS. 2 and 3 are enlarged sectional views taken along lines 2—2 and 3—3, respectively, of FIG. 1 in the direction of the arrows, illustrating means for removably mounting the device onto the receptacle containing a supply of the bubble forming solution;

FIG. 4 is an enlarged rear half section of the device shown in FIG. 1;

FIG. 5 is an enlarged front half section of the device shown in FIG. 1, turned 180°;

FIG. 6 is an enlarged vertical sectional view taken along line 6—6 of FIG. 1 in the direction of the arrows;

FIG. 7 is an enlarged rear half section, similar to FIG. 4, illustrating operation of the device of FIG. 1;

FIG. 8 is a longitudinal sectional view taken along line 8—8 of FIG. 7 in the direction of the arrows, illustrating air flow adjacent the vent opening and baffle during aspiration;

FIG. 9 is a vertical sectional view taken along line 9—9 of FIG. 7 in the direction of the arrows, also illustrating air flow adjacent the vent opening and baffle during aspiration; and

FIG. 10 is a fragmentary elevational view of an upper portion of FIG. 4 illustrating use of a second baffle in the inlet passageway.

DESCRIPTION OF PREFERRED EMBODIMENT

Referring now to the drawings in detail, particularly to FIGS. 1, 2 and 3, there is shown a bubble blowing device 10 preferably of ornamental design, one such being depicted as a sea horse in FIG. 1, removably mounted upon a receptacle 11, which contains a supply of bubble forming solution. The device 10 is formed at its base with a skirt 12 having diametrically spaced openings 13. At each opening 13 a cluster of four upstanding prongs 14 having inturned flanges 15 at their upper ends are provided in the skirt 12 for removal securement by corresponding upright detents 16 formed at the top of the supply receptacle 11. The device 10 is preferably formed of plastic material, such as styrene, and in view of the flexibility of this material the device 10 can be readily removed from the receptacle 11 by a child in exerting slight pressure on the top of the device 10 with one hand while holding the receptacle 11 in the other hand.

Referring to FIGS. 4 and 5, it will be seen that the device 10 is constituted by two substantially identical half sections 17 and 18, the peripheral face 19 of section 17 being formed with projecting pins 21 that mate with corresponding openings 22 formed in the peripheral face 23 of section 18. Interiorly each of the half sections 17 and 18 is formed with wall portions to provide separate compartments, section 17 having a diagonal wall 24 and a vertical wall 26 that is adapted to abut diagonal wall 27 and vertical wall 28, respectively, of section 18. Also, section 17 includes a wall 29 adapted to abut a wall 31 in section 18 to form a baffle, as will appear hereinafter,

3

beneath two spaced vent openings 32, 33 respectively in sections 17 and 18. Section 17 includes a fluid opening 34 and an air inlet opening 36 in vertical wall 26. It is evident that upon applying a suitable adhesive to the peripheral faces 19 and 23 and faces of walls 24, 27 and 26, 28 and 29, 31 and then assembling both of said sections together the design 10, shown in FIG. 1, is formed into a liquid tight receptacle having two useful compartments 37 and 38 for the purposes of this invention, as will appear hereinafter. The area 39 below the diagonal walls 24 and 27 is open to the atmosphere, as will be evident from FIGS. 6 and 7.

The operation of the above bubble blower will be readily apparent from FIGS. 1, 6, 7, 8 and 9. Assume, for example, that the device 10 was initially assembled to its supply receptacle 11, as shown in FIG. 1, and that it has been disengaged therefrom by tilting it with respect to the receptacle 11 and separating the prongs 14 from the detents 16. The bubble forming fluid is then poured from the receptacle 11 into the device, preferably through the exit passageway 41, until the liquid reaches the "Fill Line" in the lower portions of compartments 37 and 38, as seen in FIG. 7. The device 10 is now ready for the formation of bubbles, which is readily accomplished by blowing air into the inlet passageway 42, as indicated by the arrows, a portion of the air passing down through compartment 38 into the liquid 43 and through opening 34 into compartment 37 to cause formation of bubbles 44 in the upper portion of compartment 37. Another portion of the air blown through inlet passageway 42 passes through inlet opening 36 and into compartment 37 to force the formed bubbles 44 therein up through exit passageway 41 and into the atmosphere where the bubbles assume a larger formation. It will be evident that, as long as air is blown into the device 10, bubbles will be discharged therefrom, so that the tendency is to keep blowing air as long as the child's lungs can do so. But it has been found that the child tends to inhale or suck air from the bubble blower and in doing so inhales some of the bubble forming solution 43.

To overcome this aspirating problem the device 10 herein includes two safety vent openings 32 and 33, one on each upper side of the inlet passageway 42 and partially isolated therefrom by the baffle 29, 31. Accordingly, as air is blown into the inlet passageway 42, the baffle 29, 31 prevents the in-blown air from passing into the vent openings 32, 33. However, when the child attempts to inhale air from the device, passage of the inhaled air more readily comes from the atmosphere through the safety vent openings 32, 33 around the baffle 29, 31 and

4

thence through the inlet passageway 42, as is seen in FIGS. 8 and 9, rather than through either of the openings 34, 36. Since it is well known that air will move more readily than liquid, the vent openings 32, 33 provide a readily available source for the inhaled air and thereby make it more difficult for the bubble liquid to be inhaled. Thus, the child in using the device of this invention does not inhale any of the bubble forming liquid 43.

As a further precaution in eliminating possible intake of the solution 43, a second baffle 46, see FIG. 10, is provided at the top of compartment 38 and just below inlet opening 36, so that still greater resistance to inhalation of the solution 43 is presented. Also, the second baffle 46 acts as a restriction for controlling air flow into the fluid opening 34.

What is claimed is:

1. A device for blowing bubbles comprising, in combination, a receptacle, a reservoir in said receptacle for a bubble forming solution, said receptacle having an air space above said reservoir, an air inlet passageway in said receptacle having an opening below the level of the solution therein for forming a succession of bubbles that rise in the space above the solution, an exit passageway for emission of said bubbles from the reservoir, and said inlet passageway having a second opening above said first opening and above the level of said solution for supplying air for impelling the bubbles out of the reservoir into the exit passageway and into the atmosphere, the improvement wherein said inlet passageway includes means with a third opening above said second opening as a safety vent for preventing some of said solution from being aspirated during operation of said device, said air inlet passageway means includes a baffle adjacent said third opening for deflecting inlet air past said third opening.

2. A device in accordance with claim 1, wherein said inlet passageway includes a second baffle adjacent said second opening for controlling emission of bubbles through said exit passageway.

References Cited

UNITED STATES PATENTS

2,015,301	9/1935	Delvaux	46—7
2,118,748	5/1938	Warham	46—6
2,587,895	3/1952	Quinn et al.	46—7
3,021,639	2/1962	Allen et al.	46—7
2,711,612	6/1955	Wister	46—7

F. BARRY SHAY, Primary Examiner

C. R. WENTZEL, Assistant Examiner