



US00D624004S

(12) **United States Design Patent**
Farber

(10) **Patent No.:** **US D624,004 S**

(45) **Date of Patent:** **** Sep. 21, 2010**

- (54) **ANTI-SWAY BICYCLE MOUNT**
- (75) Inventor: **Robert Farber**, Montreal (CA)
- (73) Assignee: **Swiss Cargo Industries S.A. Inc.**, St. Jean, Quebec (CA)

6,840,418	B2 *	1/2005	Robins et al.	224/537
6,988,645	B1 *	1/2006	Nusbaum et al.	224/519
7,213,731	B1 *	5/2007	Kolda	224/537
7,469,808	B2 *	12/2008	Morales et al.	224/555
D612,320	S *	3/2010	Flaherty et al.	D12/408
2007/0057001	A1 *	3/2007	Wang	224/536
2007/0235487	A1 *	10/2007	Bogoslofski et al.	224/533

(**) Term: **14 Years**

* cited by examiner

(21) Appl. No.: **29/355,972**

Primary Examiner—Susan M Lee

Assistant Examiner—Linda G. Brooks

(22) Filed: **Feb. 17, 2010**

(74) *Attorney, Agent, or Firm*—Husch Blackwell Sanders Welsh & Katz

(51) **LOC (9) Cl.** **12-11**

(52) **U.S. Cl.** **D12/408**

(58) **Field of Classification Search** D12/406-408, D12/111, 223; 224/42.11, 515, 545, 519, 224/495, 502, 505, 506, 522, 535-537, 548, 224/552, 553, 567, 572, 324, 935, 924, 421, 224/425-427, 496, 497, 499, 490-493, 533, 224/400, 412, 419, 441-443, 447, 448, 450, 224/451, 454, 456, 459, 461, 331, 319; 280/202, 280/288.4, 304.5

See application file for complete search history.

(56) **References Cited**

U.S. PATENT DOCUMENTS

5,259,542	A *	11/1993	Newbold et al.	224/324
D447,997	S *	9/2001	Ferman et al.	D12/408
6,386,407	B1 *	5/2002	Erickson et al.	224/282
6,431,423	B1 *	8/2002	Allen et al.	224/509
6,616,023	B1 *	9/2003	Dahl et al.	224/537

(57) **CLAIM**

The ornamental design for an anti-sway bicycle mount, as shown and described.

DESCRIPTION

FIG. 1 is a front perspective view of an anti-sway bicycle mount showing the new design;

FIG. 2 is a side elevational view thereof;

FIG. 3 is an opposite side elevational view thereof;

FIG. 4 is a front elevational view thereof;

FIG. 5 is a rear elevational view thereof;

FIG. 6 is a top plan view thereof;

FIG. 7 is a bottom plan view thereof; and,

FIG. 8 is a rear perspective view thereof.

1 Claim, 5 Drawing Sheets

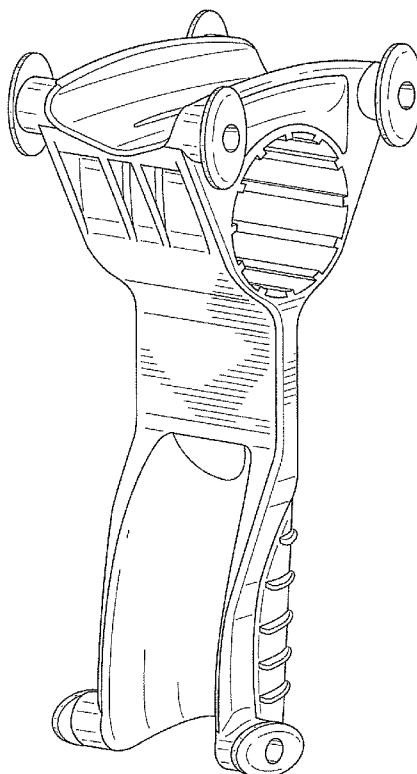

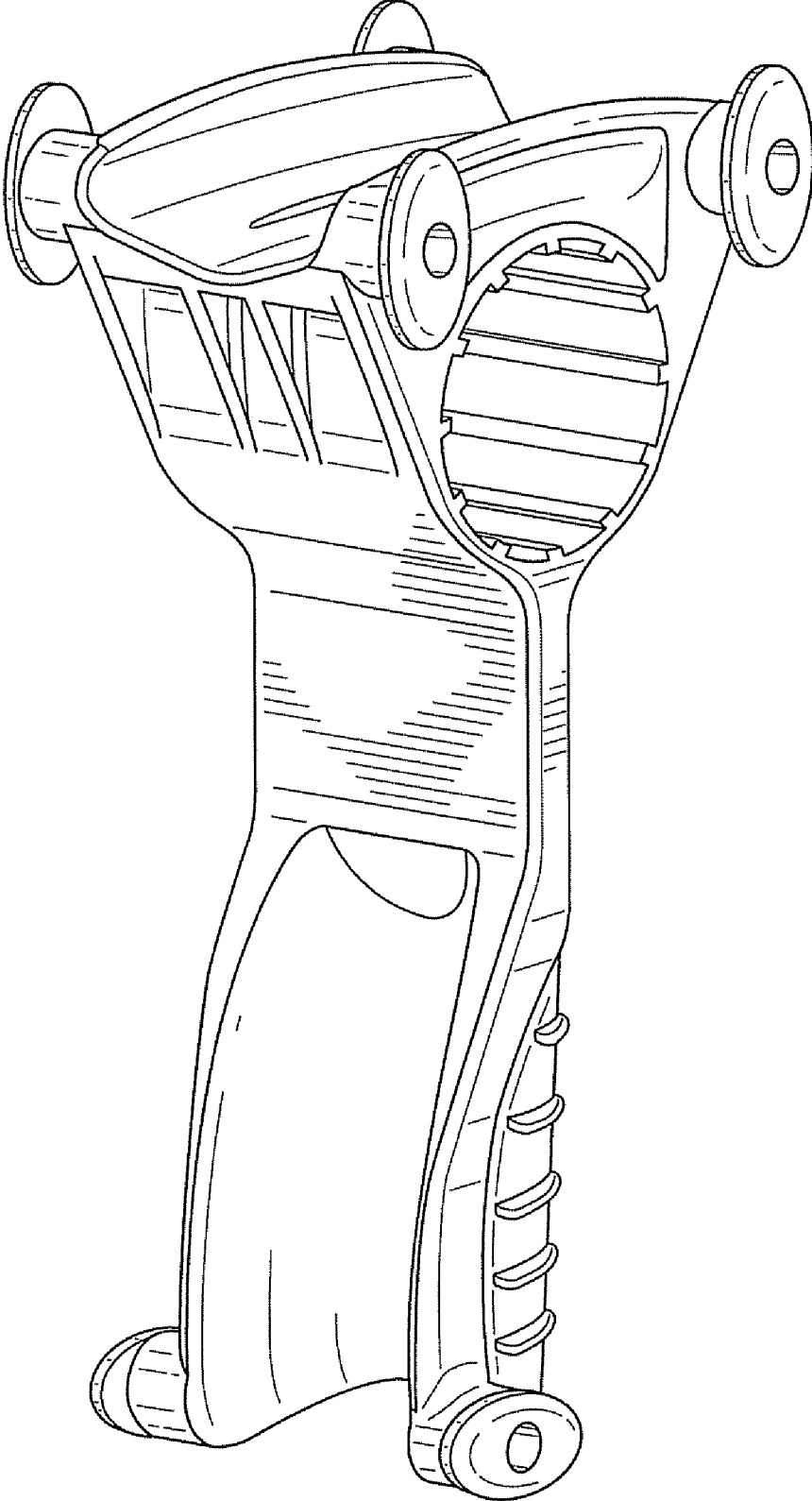

FIG. 1

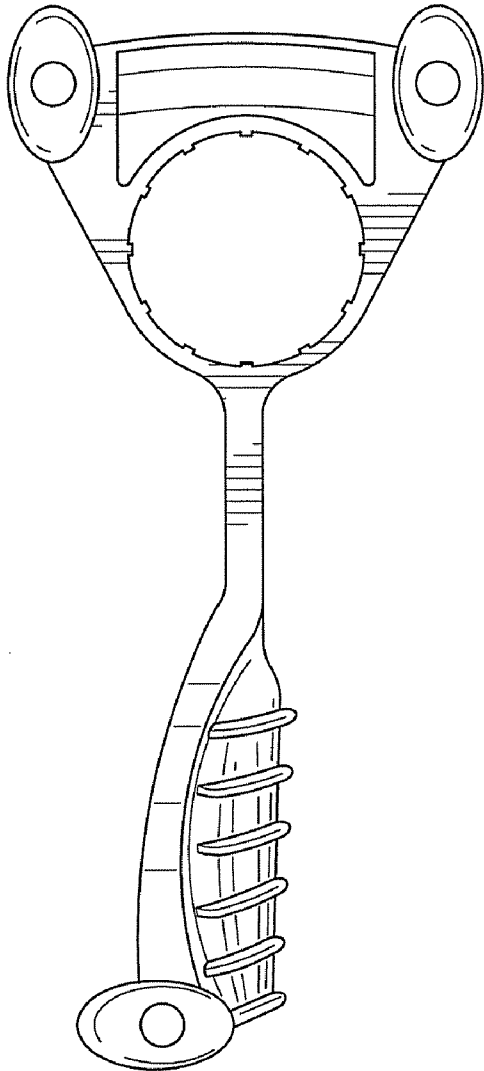

FIG. 2

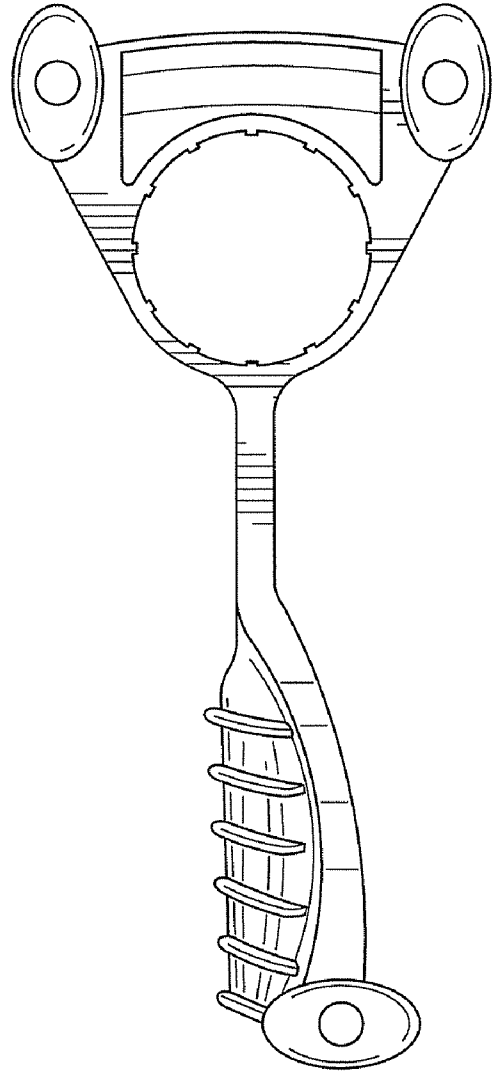

FIG. 3

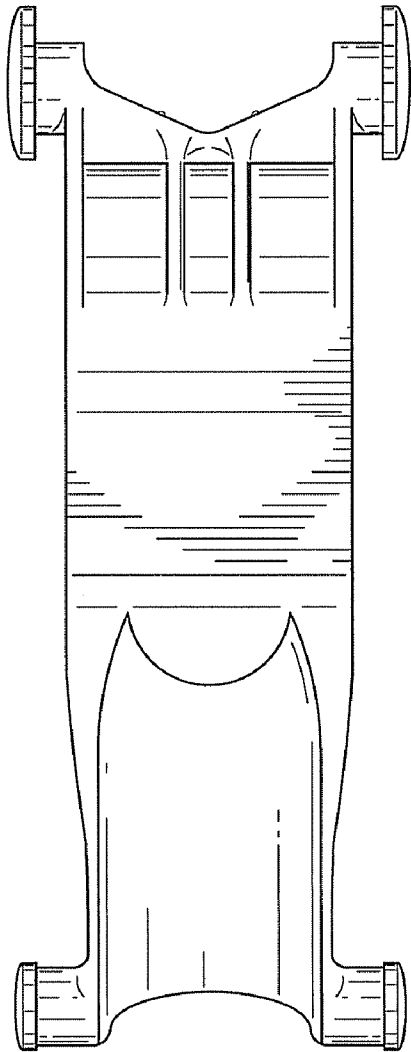

FIG. 4

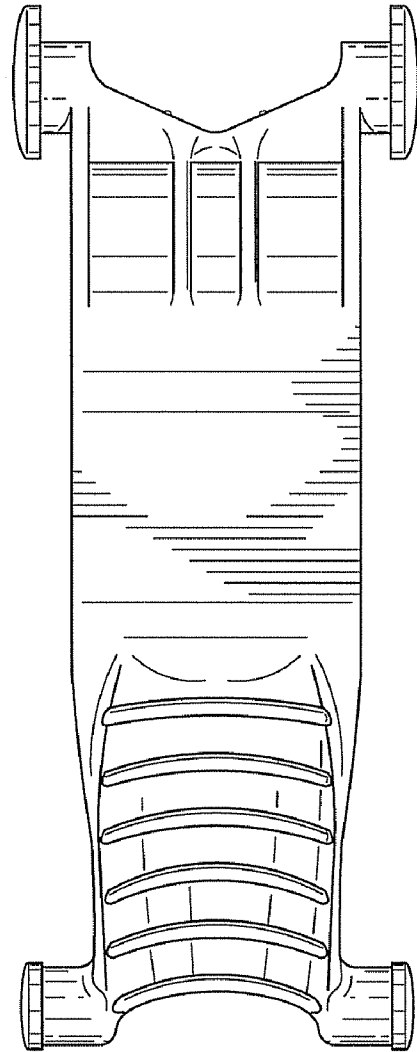

FIG. 5

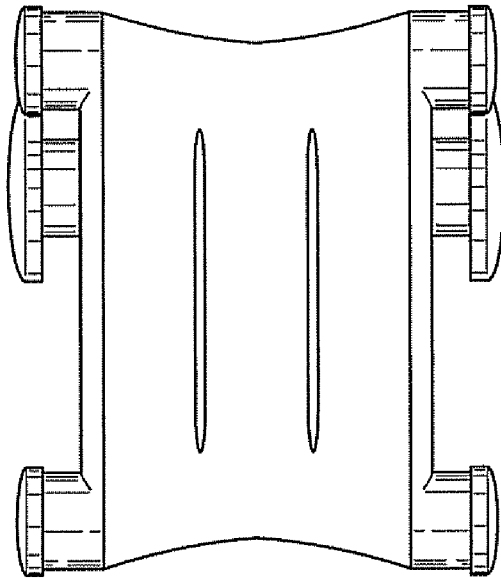

FIG. 6

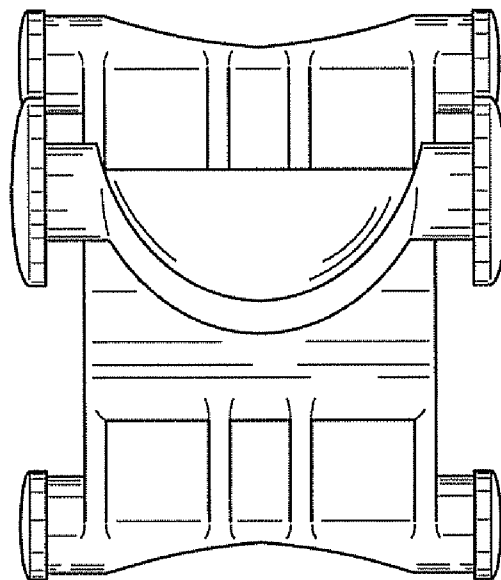

FIG. 7

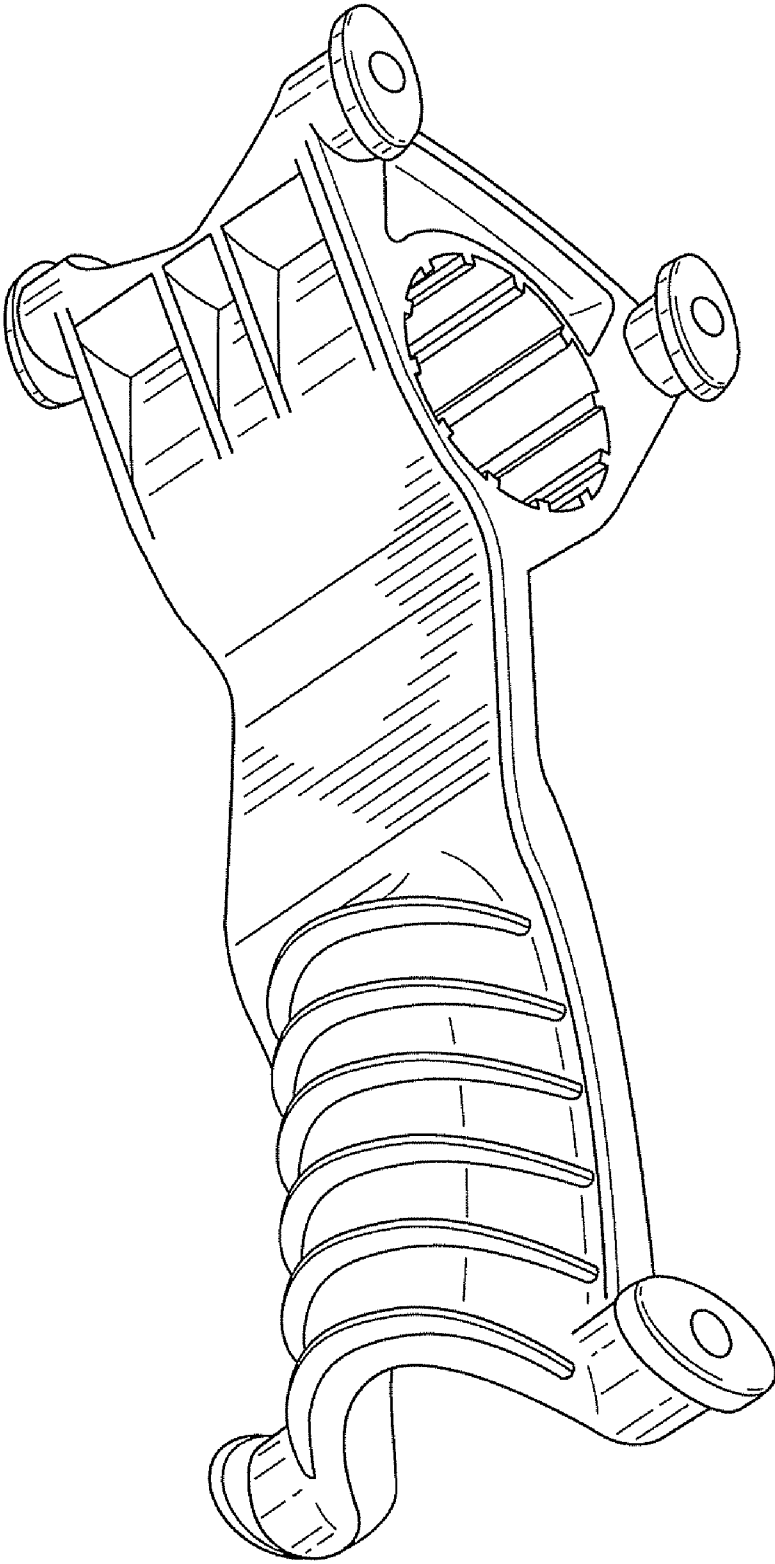

FIG. 8