

**EUROPEAN PATENT APPLICATION**

Application number: 89117777.6

Int. Cl.<sup>5</sup>: **D21G 1/00**

Date of filing: 26.09.89

Priority: 29.09.88 JP 245524/88

Date of publication of application:  
04.04.90 Bulletin 90/14

Designated Contracting States:  
**DE FR SE**

Applicant: **JUJO PAPER CO., LTD.**  
**No. 4-1, Oji 1-chome**  
**Kita-ku Tokyo(JP)**

Inventor: **Abe, Tsuyoshi c/o Jujo Paper Co., Ltd.**  
**Technology Development Center 21-1, Oji 5-chome**  
**Kita-ku Tokyo(JP)**  
Inventor: **Kobayashi, Jun c/o Jujo Paper Co., Ltd.**  
**Technology Development Center 21-1, Oji 5-chome**  
**Kita-ku Tokyo(JP)**

Representative: **Kador & Partner**  
**Corneliusstrasse 15**  
**D-8000 München 5(DE)**

**Calendering apparatus for paper making process.**

A calendering apparatus in which a nip portion is formed by a chilled roll (1, 21), a backing roll (2, 22) and an endless elastic belt (3, 23) arranged over the chilled roll and the backing roll, wherein a paper sheet (10) to be treated passes between the chilled roll and the endless elastic belt, and thus a paper sheet having a remarkably improved smoothness and gloss can be obtained by the calendering apparatus of the present invention using an endless elastic belt having a relatively long length, without the disadvantage of a heat build-up occurring in a usual calendering treatment.

**Fig. 3**

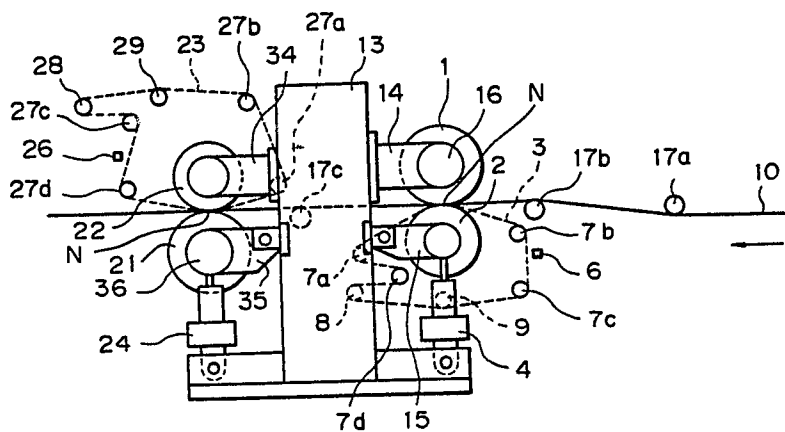

Xerox Copy Centre

## CALENDERING APPARATUS FOR PAPER MAKING PROCESS

## BACKGROUND OF THE INVENTION

## 1. Field of the Invention

5 The present invention relates to a calendering apparatus for a paper making process. More particularly, the present invention relates to a calendering apparatus used for improving the surface properties of a paper sheet by applying a smoothness, a gloss or the like to a surface of the paper sheet.

## 2. Description of the Related Art

Many types of calendering apparatuses are used in a paper making process; typical of which are a machine calender, i.e., a chilled nip calender, and a supercalender.

15 The machine calender is arranged directly down stream of a drying part in a paper making machine, i.e., in an on-line arrangement to improve the surface properties of the paper sheet, and includes at least a nip formed by two chilled rolls made of a steel.

In the supercalender the chilled roll is arranged in a vertical direction alternately with an elastic roll, and the supercalender is used as an apparatus independent of the paper making machine, i.e., in an off-line arrangement. The supercalender applies several nips to the paper under a high pressure, and is used to produce a paper sheet having a superior smoothness, such as a gravure printing paper.

20 Further, a soft nip calender apparatus including a nip formed by the elastic roll and the chilled roll as a pair has been developed, and is used in an on-line arrangement like the machine calender.

The supercalender is usually driven off-line at a low speed, due to the need to take into consideration 25 for deterioration of the elastic roll when operated under a high pressure and multiple nips conditions. Therefore, in a calendering treatment of the paper sheet, the machine calender or the soft nip calender are most widely used.

The function of the soft nip calender using the elastic roll is clearly different from that of the machine calender with regard to improving the surface properties of a paper sheet, and this difference will 30 be explained with reference to Figs. 1 and 2. In the figures, a change in the surface of the paper sheet caused by a treatment with the machine calender is illustrated by a cross section in a widthwise direction perpendicular to a running direction of the paper sheet in Fig. 1, and a change caused by the soft nip calender is illustrated in Fig. 2, in the same manner as in Fig. 1.

A cross section in the widthwise direction of the paper sheet before the calendering treatment is 35 illustrated in Fig. 1(A) and Fig. 2(A) respectively. As can be seen in Fig. 1(A) and Fig. 2(A), a thickness of the paper sheet just after a drying process is irregular; i.e., the paper sheet 10 has thick portions 10a and thin portions 10b. A cross sectional shape of the paper sheet 10 after being nipped by two chilled rolls 50 of the machine calender is illustrated in Fig. 1(B), and a cross sectional shape of the paper sheet 10 after being nipped by a chilled roll 50 and an elastic roll 51 of the soft nip calender is illustrated in Fig. 2(B). In 40 the former case, a surface layer of the thick portion 10a of the paper sheet 10 is made smooth by a pressing action of the chilled roll, but since a surface layer of the thin portion 10b of the paper sheet 10 does not come into contact with the chilled roll 50, small untreated portions remain on the paper sheet 10. In the latter case, when the paper sheet 10 is pressed with the chilled roll 50 and the elastic roll 51, a surface 11a opposite to the chilled roll 50 of the paper sheet 10 is made flat by the even cylindrical surface 45 of the chilled roll 50, and irregular shape of the surface 11a before the calendering operation is transferred to and duplicated at another surface 11b of the paper sheet 10. The elastic roll 51 is deformed in accordance with the duplicated irregular shape of the surface 11b, due to its own elasticity, and accordingly, the surface 11a is made and remains smooth during the first stage of the calendering treatment and has a required gloss. The paper sheet 10 is then again treated by another calendering unit in which the chilled roll 50 and the elastic roll are arranged in a reversed relationship, and thus the surface 11b is made flat. 50 Accordingly, both surfaces 11a and 11b are then smooth and have the desired gloss.

The cross sectional shapes of the paper sheets after receiving the calendering treatment are illustrated in Figs. 1(C) and 2(C). As can be seen from Fig. 1(C), the paper sheet treated with the machine calender has substantially the same thickness but the density and surface properties thereof are irregular. Further as can be seen from Fig. 2(C), the paper sheet treated with the soft nip calender has an irregular thickness but

the density is constant, and thus the surface properties are improved in that the surface smoothness is uniform. Portions 12 to which the calendering treatment of the surface layer of the paper sheet in Fig. 1(C) and Fig. 2(C) is applied are shown by hatching.

5 The surface of the paper sheet is made smoother by the soft nip calender, and therefore, the printability of the paper sheet treated with the soft nip calender is superior to that of the paper sheet treated with the machine calender.

Nevertheless the soft nip calender has the following drawbacks. First the elastic roll of the soft nip calender is constructed by a layer of a synthetic resin having a high thermal resistance covering a metallic roll. The synthetic resin layer has an extremely low conductivity and a large coefficient of thermal expansion compared with those of the surface of the metal roll. Therefore, when the paper sheet in which a distribution of a water content and/or a weight per unit area of the paper sheet is irregular, or in which small fiber blocks are included, is treated with the soft nip calender, heat is retained by portions of the elastic roll in contact with thick portions of the paper sheet, and accordingly problems such as peeling at a boundary between the metallic roll and the synthetic resin layer, or the elastic roll becomes useless because the heated portion of the synthetic resin layer cannot resume its original shape, due to heat stress hysteresis, will occur.

Note the calendering treatment should not be carried out at a high temperature and a high pressure, as this will shorten the working life of the elastic roll. In particular, when the elastic roll is used on-line in an apparatus in which the running speed of the paper sheet is very high, the condition of the elastic roll must be closely observed at all times.

20 Consequentially, although the use of the elastic roll provide a superior effect, when the calendering apparatus including the elastic roll is continuously used in an actual industrial operation, often the use of the elastic roll does not provide a satisfactory calendering treatment capable of producing a paper sheet having a desired quality.

25

#### SUMMARY OF THE INVENTION

An object of the present invention is to solve the above problem caused by the elastic roll and to provide a calendering apparatus capable of producing a paper sheet having the same level of quality as that of a paper sheet treated by a calendering apparatus including the elastic roll.

Therefore, according to the present invention, there is provided a calendering apparatus for a paper making process including at least a nip constituted by two rolls, wherein the two rolls are a chilled roll and a backing roll, and an endless elastic belt having a longer length than a circumferential length of the backing roll is arranged over a nip portion of the backing roll so that the endless elastic belt is moved by a rotation of the backing roll and nips a paper sheet with the chilled roll at the nip portion thereof.

35 The calendering apparatus in accordance with the present invention can be applied to a paper sheet without a coating layer on a surface thereof and a paper sheet with a coating layer on a surface thereof. The later paper sheet includes an art paper, a coated paper, or a recording paper such as a heat sensitive recording paper, a pressure sensitive recording paper, and an ink jet recording paper.

40 In the calendering apparatus in accordance with the present invention, when a paper sheet passes through a nip portion, a surface of the paper sheet (hereinafter referred to as a front surface) is pressed by the chilled roll, and another surface of the paper sheet (hereinafter referred to as a back surface) is pressed by the endless elastic belt. In this case, any irregularities of the front surface, i.e., concave portions and convex portion of the front surface, are made uniform, and these irregularities of the front surface are transferred to the back surface, whereby the irregularities of the front surface of the paper sheet are added to the irregularities of the back surface. This amplified irregularity of the back surface is completely observed by an elasticity of the endless elastic belt, and accordingly, the chilled roll can apply uniform a smoothness and gloss to the front surface not having irregularities.

45 A partial heat build-up may be generated in the endless elastic belt upon applying the surface treatment, but since the endless elastic belt has a relatively long length compared with a circumferential length of the backing roll, i.e., the endless elastic belt has a portion not in contact with the nipping portion, a heated portion of the endless elastic belt is sequentially dissipated or cooled when not in contact with the chilled roll, whereby heat stress in the endless elastic belt is reduced and the elasticity of the endless elastic is recovered. This portion is then circulated until in contact with the nipping portion. Therefore, according to the present invention, an abnormal high temperature and a deformation of the endless elastic belt is prevented. Note, to lower the temperature of the endless elastic belt, preferably a cooling device is arranged at a position near to a pathway of the endless elastic belt.

55

## BRIEF DESCRIPTION OF THE DRAWINGS

Figures 1(A) to 1(C) are cross sectional views illustrating various changes of cross sections in a widthwise direction perpendicular to a running direction of paper sheets during a conventional calendering treatment of the paper sheet;

Figs. 2(A) to 2(C) are cross sectional views illustrating various changes of cross sections in a widthwise direction perpendicular to a running direction of paper sheets during a calendering treatment of a paper sheet in accordance with the present invention;

Fig. 3 is a schematic front view illustrating an embodiment of a calendering apparatus in accordance with the present invention; and,

Figs. 4 to 9 are schematic views illustrating various arrangements of an endless elastic belt in the calendering apparatus in accordance with the present invention.

## DESCRIPTION OF THE PREFERRED EMBODIMENTS

The calendering apparatus in accordance with the present invention is described in detail with reference to the attached drawings illustrating an embodiment of the calendering apparatus of the present invention.

As shown in Fig. 3 illustrating an embodiment of a calendering apparatus in accordance with the present invention, a chilled roll 1 is rotatably mounted on a calender frame 13 through a fitting arm 14. A backing roll 2 arranged in a mutually opposing state in a vertical direction at a position below the chilled roll 1 is mounted on a movable fitting arm 15 having end pivotably arranged on the calender frame 13. The backing roll 2 is provided with a device for rotating the backing roll 2 (not shown). Further a drive portion of a lift up device 4 is fixed to a free end of the movable fitting arm 15, whereby the movable fitting arm 15 is swung up about the pivoting point by a pressure of the lift up device 4, and the backing roll 2 is brought into contact with the chilled roll 1 under pressure. An endless elastic belt 3 is arranged such that portion of the endless elastic belt 3 covers a nipping portion N or the backing roll 2 while pressing the against the backing roll, and the elastic belt 3 runs over the backing roll 2, retaining rolls 7a, 7b, 7c and 7d, a stretching roll 8, and a guide roll 9. When the free end of the movable fitting arm 15 is swung up by the lift up device 4, the pathway of the endless elastic belt 3 is adjusted by a change of a position of the guide roll 9, and a tension of the endless elastic belt 3 is adjusted by a change of a position of the stretching roll 8.

The chilled roll 1 includes a heating means 13 heated by a heating medium, such as steam, hot water, electric induction or the like. Further, a cooling device 6 such as an air shower, a water spraying device or the like is arranged at a position near to a pathway of the endless elastic belt 3, so that a cooling action is applied toward the heated endless elastic belt 33 and the heated endless elastic belt 33 is suitably cooled. Sheet rolls 17a, 17b are arranged to supply the paper sheet 10 between the chilled roll 1 and the endless elastic belt 3.

When the paper sheet 10 is treated by a calender having only one set of rolls composed of the chilled roll 1, the backing roll 2 and the endless elastic belt, 3 as described above, the surface in contact with the chilled roll 1 of the paper sheet, i.e., the front surface thereof, is made smooth compared with the surface in contact with the endless elastic roll 3, i.e., the back surface thereof.

Therefore, when it is necessary to provide both surfaces of the paper sheet with the same smoothness, preferably a second set of rolls in which the components are arranged in reverse to those of the first set of rolls, and the paper sheet is passed through the second set of rolls after being treated by the first set of rolls. In Fig. 1, the second set rolls is arranged at the side of the calender frame 11 from which the paper sheet is output. In the second set of rolls, the endless elastic belt 23 is in contact with the paper sheet 10 from above, and the backing roll 22 over which the endless elastic belt 23 is arranged is mounted on a movable fitting arm 34 mounted at a upper position of a pathway of the paper sheet 10. The backing roll 22 is connected with a device for rotating the backing roll 22 (not shown). The endless elastic belt 23 is arranged over the backing roll 22, retaining rolls 27a, 27b, 27c and 27d, a stretching roll 28, and a guide roll 29, is pressed against a surface of the backing roll 22 under a tension adjustable by the stretching roll 28. A cooling device 26 is mounted at a position near to the pathway of the endless elastic belt 23. The chilled roll 34 including a heating means 36 is pivotally arranged on a calender frame 13 via a movable fitting arm 34, and can be brought into contact with the backing roll 22, under pressure, by an upward operation of a lift up device 24.

When the above described calendering apparatus is operated by a rotation of the backing rolls 2 and 22 and the paper sheet 10 is supplied to the calendering apparatus, the front surface of the paper sheet 10 is treated by the first set of rolls and the back surface of the paper sheet is treated by the second set of rolls. At this stage, the lift up devices 4 and 24 lift corresponding movable fitting devices 15 or 25 upward,

respectively, and accordingly the backing roll 2 is pressed against the chilled roll 1 and the chilled roll 21 is pressed against the backing roll 22. Since the endless elastic belt 3 and 23 are arranged over the backing rolls and 22, respectively, the paper sheet 10 is pressed between the endless elastic belts 3 and 23 and the chilled rolls 1 and 21, to smooth the surfaces thereof. That is, when the paper sheet is pressed against the chilled rolls 1 and 21, all irregularities of both surface of the paper sheet 10 are absorbed by the endless elastic belts 3 and 23, and thus the chilled roll 1 and 21 can smooth the surfaces of the paper sheet and apply the gloss to those surfaces. The surfaces of the paper sheet treated with the calendering apparatus illustrated in Fig. 3 are the same as those of the paper sheet described with reference to Fig. 2.

Preferably, the backing roll 2 and 22 are metallic rolls, and the chilled roll per se may be used as the backing roll or a crown controlled roll may be used to adjust a thickness of the paper sheet. The chilled roll has no elasticity on a surface thereof, and the heating devices 16 and 36 can be omitted depending on the quality of the paper sheet to be manufactured.

The structure of the endless elastic belts 3,23 is not limited, and the endless elastic belt is usually formed by adhering or coating a synthetic resin having a heat resistance, a pressure resistance, and a good compression elasticity, to a fabric made of fibers having a heat resistance. Also, preferably the surface of the endless elastic belt is polished to a surface roughness of between 1  $\mu\text{m}$  and 20  $\mu\text{m}$ . A preferable range of the elasticity of the synthetic resin is a shore hardness D of between 50 and 75. The hardness may be adjusted in accordance with the type of resin used, or a type or a quantity of an additive added to the resin. Generally, the lower the hardness, the better the smoothness and a gloss of the paper sheet, but preferably the elasticity of the resin has is at least capable of following a surface roughness of the paper sheet to be treated. Accordingly, when the hardness of the resin is too low, plastic deformation may occur, and thus the life of the belt may be shortened. If the hardness of the resin is too high, the belt cannot follow the surface roughness of the paper sheet to be treated and the desired smoothness and gloss cannot be obtained.

The thickness of the synthetic resin layer of the belt can be made thinner, to control heat build-up and prolong the life of the elastic belt, but a surface treated with such an endless elastic belt will probably have a surface similar to a surface treated with a chilled nip calender. Conversely, if the thickness of the synthetic resin layer of the belt is made thicker, the surface of the paper sheet is improved, but if the thickness of the belt is too thick, the durability of the belt is poor. Therefore, a preferable thickness of the synthetic resin layer is between 1 mm and 10 mm. An endless elastic belt having a synthetic resin layer on both side thereof is suitable for a polishing operation, because the synthetic resin layer opposite to the synthetic resin layer to be polished can be firmly held on a polishing table during the polishing operation. If the endless elastic belt having a sufficient strength can be obtained by only the synthetic resin layer, it is not necessary to use the base fabric. Further, it is possible to use a belt made of a rubber, a metal or the like in stead of the base fabric.

With regard to a method of rotating or driving the pair of rolls or the endless elastic belt, a rotating or drive apparatus may be arranged at either one of the pair of rolls or at the endless elastic belt. Preferably, a rotating device is provided at the pair of rolls and a drive device at the endless elastic belt, to lower the load imposed on the endless elastic belt at a start of the operation of the apparatus.

Figures 4 - 9 illustrates various examples of the arrangement of endless elastic belt.

In the arrangement illustrated in Fig. 4, the second set of rolls includes a chilled roll 21, a backing roll 22, and an endless elastic belt 23 arranged in reverse to the arrangement of a first set of rolls including a chilled roll 1, a backing roll 2 and an endless elastic belt 3. In the case, both surfaces of a paper sheet 10 are treated in the same way as described with reference to Fig. 3.

In the arrangement illustrated in Fig. 5, one side surface of a paper sheet is treated twice by two chilled rolls of two sets of rolls, to provide a smoother surface. In this case, one endless elastic belt is used for both sets of rolls and is used as a guide for the paper sheet. In the arrangement illustrated in Fig. 6, four nips are use to twice treat each surface. Namely, two backing rolls 2a, and 2b are arranged with a chilled roll 1, and an endless elastic belt 3 is arranged over the two backing rolls 2a and 2b and the chilled roll 1, and two backing rolls 22a and 22b are arranged with the chilled roll 21 and two endless empty belts 23a and 23b are independently arranged over the two backing roll 22a and 22b.

In the arrangement illustrated in Fig. 7 a paper sheet 10 pretreated by a machine calender 4 is treated by a set of rolls having the same arrangement as that illustrated in an upper portion in Fig. 7, to treat the same surface of the paper sheet with two nips. In the arrangement illustrated in Fig. 8, two of rolls including four nips, are arranged with a chilled roll 1, to treat both surfaces of the paper sheet 10. Three endless elastic belts 3a, 3b, and 3c are used for a chilled roll 1 to make the four nips in an upper portion of this arrangement, and the four nips are formed between the chilled roll 21 and an endless elastic belt 23 in a lower portion thereof.

In the arrangement illustrated in Fig. 9, the calendering apparatus in accordance with the present invention is combined with a conventional machine calender. In the arrangement, two backing roll 2a and 2b and two endless elastic belts 3a, 3b are alternately arranged over two chilled rolls 1a and 1b, in place of an elastic roll used in the conventional machine calender, and a paper sheet 10 dried by a dryer 41 is supplied in an on-line fashion. The conventional machine calender can be easily converted to an calendering device in accordance with the present invention.

The above arrangements of the components constituting the calendering apparatus in accordance with the present invention are only examples, and it is apparent that the present invention can be attained by suitable combination of any of the above, in accordance with the desired qualities of the paper sheets to be treated.

The following tests were performed to show the different effects obtained by the calendering apparatus in accordance with the present invention and a conventional chilled nip calender.

Examples 1, and 2 of the present invention were produced by the calendering apparatus having the constitution illustrated in Fig. 3, by changing a shore hardness of the endless elastic belt. The composition of the endless elastic belt was as follows:

#### Base Fabric

Warp Yarn, i.e., a yarn parallel to a running direction of the belt: Nylon monofilament having a diameter of 0.43 mm  
Weft Yarn: Nylon monofilament having a diameter of 0.52 mm  
Weaving pattern: Double face fabric  
Thickness: 1.8 mm

#### Coating

A urethane resin was coated on a surface of the base fabric by an extruder so that the urethane resin is permeated the base fabric, and the surface was polished.

Thickness of the surface layer of the urethane resin: 1.67 mm

Shore hardness D of the surface of the urethane resin: 70 (Example 1)

55 (Example 2)

Roughness of the polished surface of the urethane resin: 16  $\mu\text{m}$

In the comparative Example, a conventional chilled nip calender having two nips was used.

The calendering treatments of Examples 1, 2 and Comparative Example were performed by treating a free sheet having a weight per unit area of 64 g/m<sup>2</sup> with two nips at a line pressure of 56 kg/cm and a roll temperature of 70 °C, and a running speed of the paper of 1000 m/sec.

The results of the above tests are shown in Table 1.

Table 1

Properties of Paper Sheet		Example	Example 2	Comparative Example Chilled Nip Calender
		Shore hardness D	Shore hardness D	
		70	55	
Mean Density (g/cm <sup>2</sup> )		0.82	0.81	0.84
Smoothness (Sec)	F	64.8	68.6	56.3
	W	61.4	65.7	39.3
Gloss (%)	F	10.8	11.2	7.9
	W	9.7	10.3	6.0
Note				
Smoothness: JIS P-8119				
Gloss : JIS P-8142				
F : Surface in contact with a felt during the paper making process				
W : Surface in contact with a wire during the paper making process				

As can be seen from Table 1, the paper sheets treated with the calendering apparatus in accordance with the present invention have a superior smoothness and gloss, and differences between the smoothness and the gloss of the front surface denoted as F in Table 1 and the back surface denoted as W in Table 1 are small.

It is apparent that it is possible to improve the smoothness and the gloss of the paper sheet by the treatment using the calendering apparatus of the present invention, compared with the treatment using the conventional chilled nip calender, and to remarkably increase the working life of an elastic belt opposing the chilled roll, compared with a conventional elastic roll. Further, since a treatment under a high pressure and a high temperature can be performed in the calendering apparatus in accordance with the present invention, it become possible to produce a paper sheet having remarkably improved qualities and printability.

### Claims

1. A calendering apparatus for a paper making process including at least a nip (N) constituted by two rolls (1, 21; 2, 2a, 2b, 22), characterized in that said two rolls (1, 21; 2, 2a, 2b, 22) comprise a chilled roll (1, 21) and backing roll (2, 2a, 2b, 22), and an endless elastic belt (3, 3a, 3b, 3c, 23, 23a, 23b) having a longer length than a circumferential length of the backing roll (2, 2a, 2b, 22) is arranged over a nip portion (N) of the backing roll (2, 2a, 2b, 22) so that the endless elastic belt (3, 3a, 3b, 3c, 23, 23a, 23b) can be moved by a rotation of the backing roll (2, 2a, 2b, 22) and nips a paper sheet (10) against the chilled roll (1, 21) at a nip portion (N) thereof.

2. A calendering apparatus according to claim 1, characterized in that said chilled roll (1, 21) includes a heating means (16, 36).

3. A calendering apparatus according to claim 1, characterized in that two nips (N) are formed by arranging two backing rolls (2, 2a, 2b, 22) and at least an endless elastic belt (3, 3a, 3b, 3c, 23, 23a, 23b) against two positions of a circumferential surface of a chilled roll (1, 21), whereby a calendering treatment of a surface of the paper sheet (10) is performed twice.

4. A calendering apparatus according to claim 1, characterized in that two sets of rolls (1, 21; 2, 2a, 2b, 22) including at least a nip (N) respectively, are arranged so that a calendering treatment can be applied to both surfaces of the paper sheet (10).

5. A calendering apparatus according to claim 1, characterized in that a cooling device (6, 26) is arranged at a position near to a pathway of the endless elastic belt (3, 3a, 3b, 3c, 23, 23a, 23b), to cool the endless elastic belt (3, 3a, 3b, 3c, 23, 23a, 23b).

6. A calendering apparatus according to claim 5, characterized in that the cooling device (6, 26) is an

air shower.

7. A calendering apparatus according to claim 5, characterized in that the cooling device (6, 26) is a water spraying device.

5

10

15

20

25

30

35

40

45

50

55

*Fig. 1 (A)*

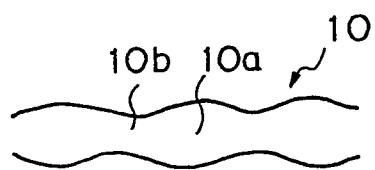

*Fig. 2 (A)*

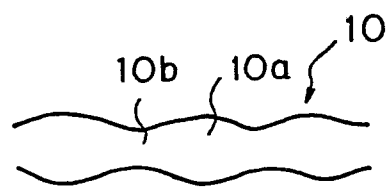

*Fig. 1 (B)*

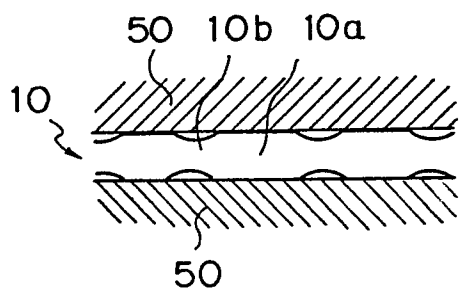

*Fig. 2 (B)*

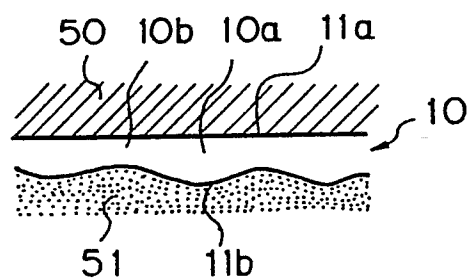

*Fig. 1 (C)*

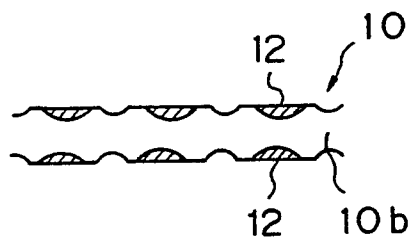

*Fig. 2 (C)*

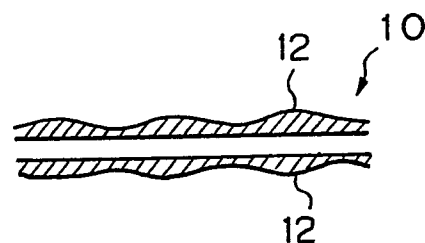

Fig. 3

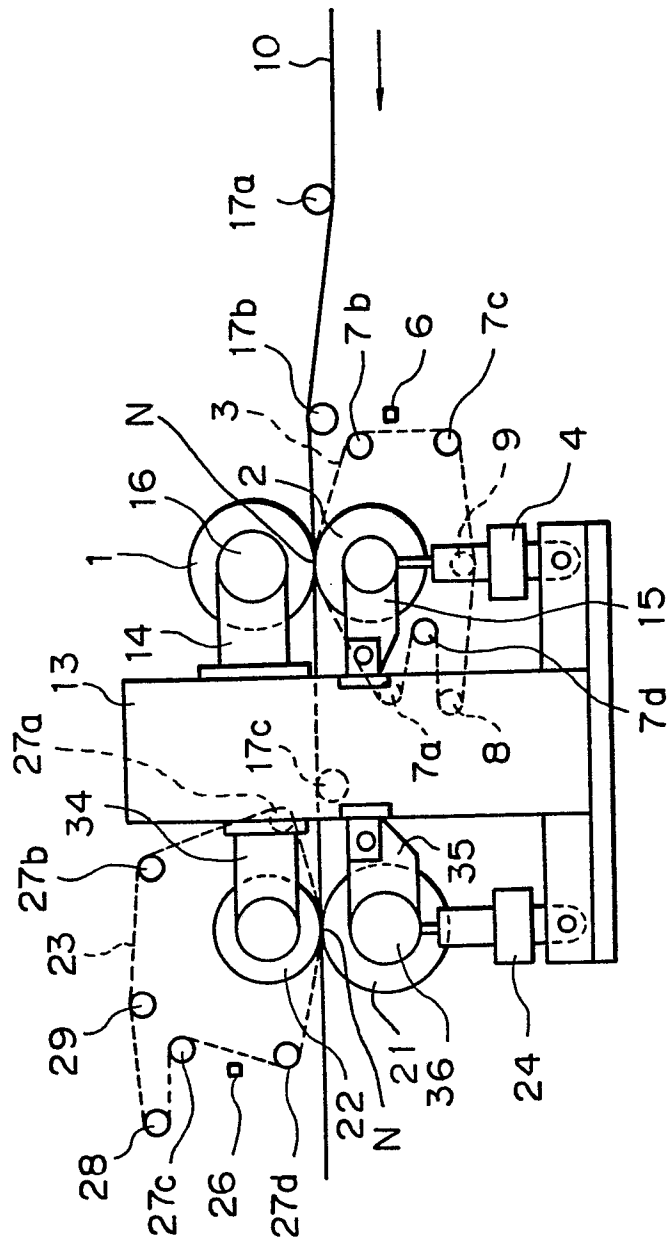

Fig. 4

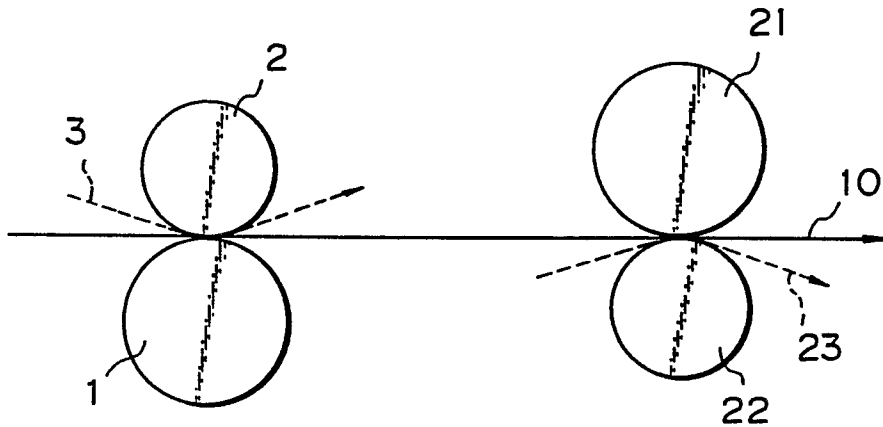

Fig. 5

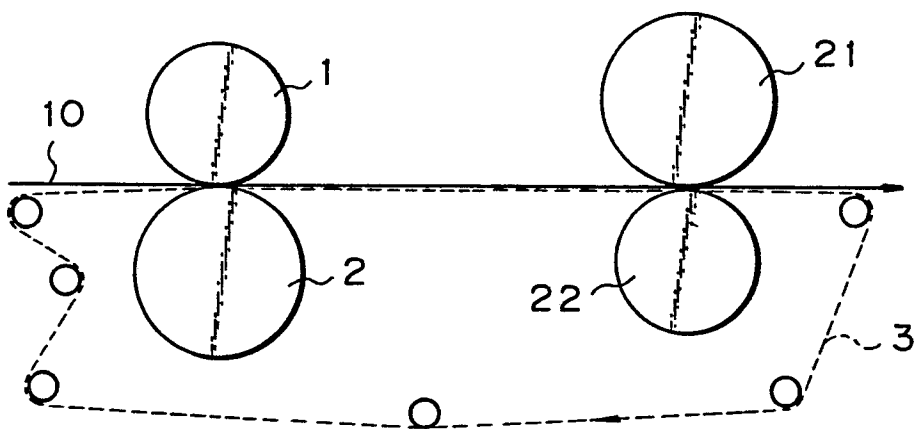

Fig. 6

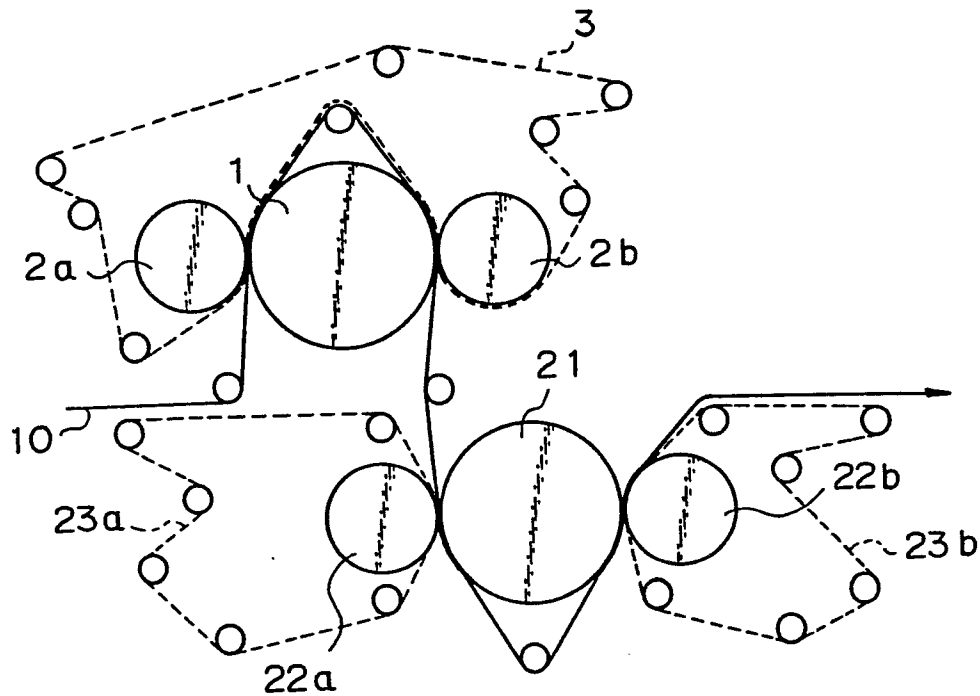
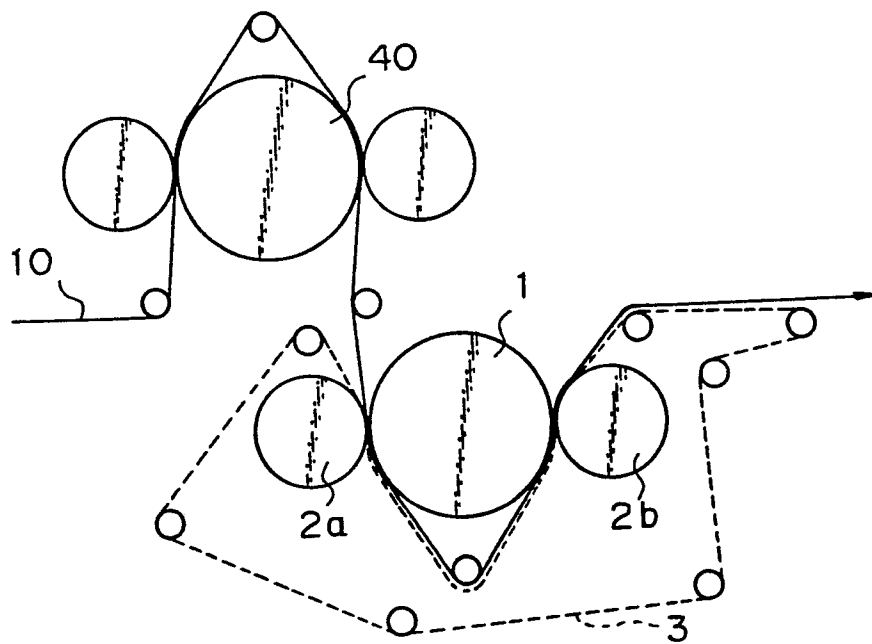
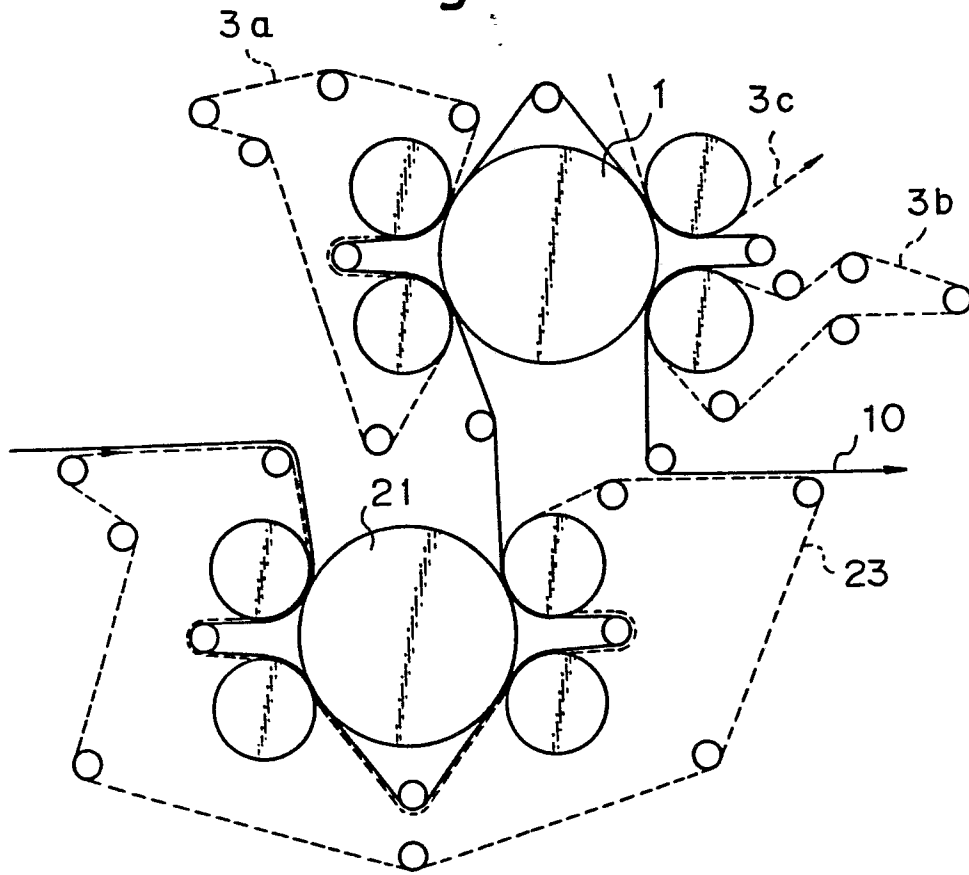

Fig. 7



**Fig. 8**



**Fig. 9**

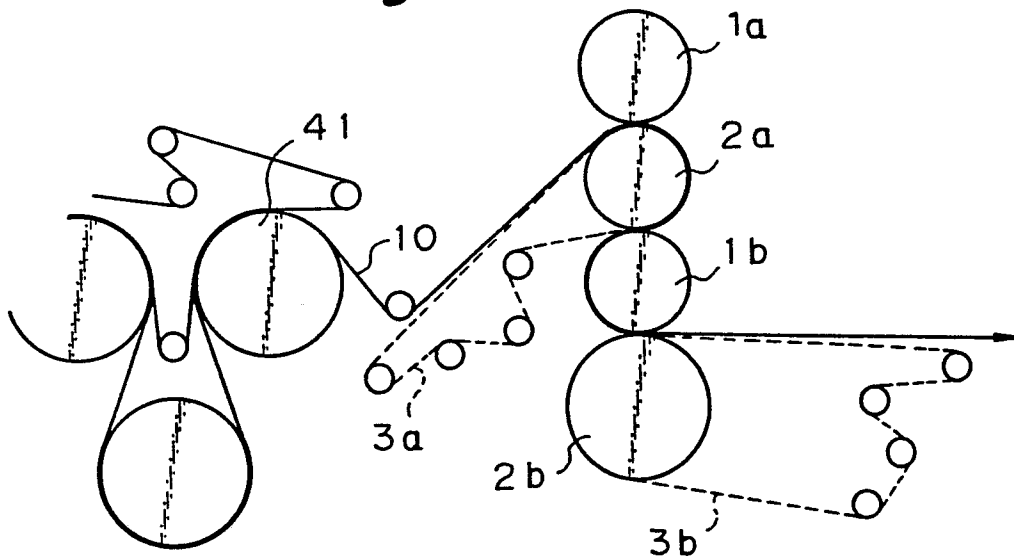



DOCUMENTS CONSIDERED TO BE RELEVANT			
Category	Citation of document with indication, where appropriate, of relevant passages	Relevant to claim	CLASSIFICATION OF THE APPLICATION (Int. Cl.5)
X	FR-A-2588293 (OY WARTSILA) * the whole document *	1, 4	D21G1/00
A	----	3	
X	GB-A-968938 (KUSTERS) * the whole document *	1-3, 5	
			TECHNICAL FIELDS SEARCHED (Int. Cl.5)
			D21G
The present search report has been drawn up for all claims			
Place of search THE HAGUE		Date of completion of the search 09 NOVEMBER 1989	Examiner DE RIJCK F.
<b>CATEGORY OF CITED DOCUMENTS</b> X : particularly relevant if taken alone Y : particularly relevant if combined with another document of the same category A : technological background O : non-written disclosure P : intermediate document		T : theory or principle underlying the invention E : earlier patent document, but published on, or after the filing date D : document cited in the application I : document cited for other reasons ..... & : member of the same patent family, corresponding document	