



- (51) **International Patent Classification:**  
*G02F 1/1335* (2006.01) *G02F 1/1333* (2006.01)
- (21) **International Application Number:**  
PCT/CN2016/082900
- (22) **International Filing Date:**  
20 May 2016 (20.05.2016)
- (25) **Filing Language:** English
- (26) **Publication Language:** English
- (30) **Priority Data:**  
201520876963.8 5 November 2015 (05.11.2015) CN
- (71) **Applicants:** **BOE TECHNOLOGY GROUP CO., LTD.** [CN/CN]; No.10 Jiuxianqiao Rd., Chaoyang District, Beijing 100015 (CN). **BOE OPTICAL SCIENCE AND TECHNOLOGY CO., LTD.** [CN/CN]; No.2 Haitang Street, Suzhou Industrial Park, Suzhou, Jiangsu 215021 (CN).
- (72) **Inventors:** **CHEN, Huafeng**; No.9 Dize Rd., BDA, Beijing 100176 (CN). **WU, Chunming**; No.9 Dize Rd., BDA, Beijing 100176 (CN).
- (74) **Agent:** **TEE & HOWE INTELLECTUAL PROPERTY ATTORNEYS**; Yuan CHEN, 10th Floor, Tower D, Min-

sheng Financial Center, 28 Jianguomennei Avenue, Dongcheng District, Beijing 100005 (CN).

- (81) **Designated States** (*unless otherwise indicated, for every kind of national protection available*): AE, AG, AL, AM, AO, AT, AU, AZ, BA, BB, BG, BH, BN, BR, BW, BY, BZ, CA, CH, CL, CN, CO, CR, CU, CZ, DE, DK, DM, DO, DZ, EC, EE, EG, ES, FI, GB, GD, GE, GH, GM, GT, HN, HR, HU, ID, IL, IN, IR, IS, JP, KE, KG, KN, KP, KR, KZ, LA, LC, LK, LR, LS, LU, LY, MA, MD, ME, MG, MK, MN, MW, MX, MY, MZ, NA, NG, NI, NO, NZ, OM, PA, PE, PG, PH, PL, PT, QA, RO, RS, RU, RW, SA, SC, SD, SE, SG, SK, SL, SM, ST, SV, SY, TH, TJ, TM, TN, TR, TT, TZ, UA, UG, US, UZ, VC, VN, ZA, ZM, ZW.
- (84) **Designated States** (*unless otherwise indicated, for every kind of regional protection available*): ARIPO (BW, GH, GM, KE, LR, LS, MW, MZ, NA, RW, SD, SL, ST, SZ, TZ, UG, ZM, ZW), Eurasian (AM, AZ, BY, KG, KZ, RU, TJ, TM), European (AL, AT, BE, BG, CH, CY, CZ, DE, DK, EE, ES, FI, FR, GB, GR, HR, HU, IE, IS, IT, LT, LU, LV, MC, MK, MT, NL, NO, PL, PT, RO, RS, SE, SI, SK, SM, TR), OAPI (BF, BJ, CF, CG, CI, CM, GA, GN, GQ, GW, KM, ML, MR, NE, SN, TD, TG).

**Published:**  
— with international search report (Art. 21(3))

(54) **Title:** BACKLIGHT ASSEMBLY AND DISPLAY APPARATUS

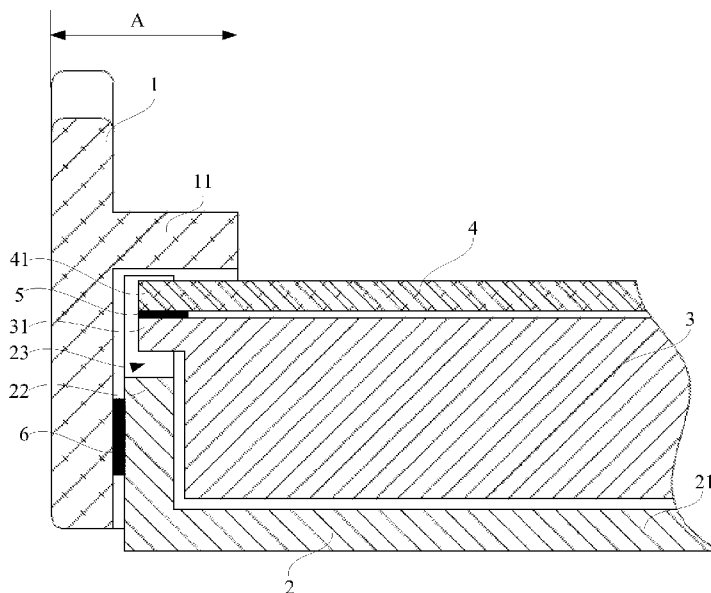

FIG. 2

(57) **Abstract:** A backlight assembly includes: a frame (1) with at least one support bar (11) configured to support a display panel; a light guide plate (3) with at least one support portion (31) protruding from at least one side of the light guide plate (3); and a film assembly (4) including an optical film (11) between the at least one support bar (11) and the light guide plate (3), wherein the optical film is provided with at least one flange (41) protruding from at least one side of the film assembly (4) and over the at least one support portion (31) on a surface of the at least one support portion (31) facing the at least one support bar (11).



## BACKLIGHT ASSEMBLY AND DISPLAY APPARATUS

### CROSS-REFERENCE TO RELATED APPLICATION

**[001]** The present application claims priority to Chinese Patent Application No. 5 201520876963.8 filed on November 5, 2015, the disclosure of which is hereby incorporated by reference in its entirety.

### TECHNICAL FIELD

**[002]** The present disclosure relates generally to display technologies, and more 10 specifically to a backlight assembly and a display apparatus.

### BACKGROUND

**[003]** In many applications, a relatively flat structure, such as a panel, a diaphragm, etc., may need to be securely fixed onto other structures. For example, a liquid 15 crystal display (LCD) apparatus may need a backlight module to provide light to the liquid crystals for modulation. A typical backlight module may include a light source, such as a light-emitting diode (LED) light source, a light guide plate to guide the light from the light source, and an optical film assembly configured to diffuse the light. With the continuous advancement of the LCD technologies, the 20 LED backlight module is moving towards the direction of narrower bezels, which may make it more difficult to secure the backlight module. This may become a more prominent issue in vehicle onboard display applications, where a more stable structure of the backlight module may be needed.

**[004]** In a first mounting method, the optical film assembly is arranged above the 25 frame in the backlight module. In a second mounting method, the optical film assembly is disposed below the frame in the backlight module.

**[005]** In existing technologies, as a result of the methods of mounting the optical film in the backlight module, the distance from an edge of an effective display area

of the display apparatus to an edge of the light guide plate can be relatively small. As such, shadowing and uneven lighting can occur near mounting brackets of the backlight module. Therefore, it may be difficult to design the display apparatus with narrow bezels using the conventional mounting methods.

5

## SUMMARY

**[006]** In an aspect, a backlight assembly is provided including: a frame with at least one support bar configured to support a display panel; a light guide plate with at least one support portion protruding from at least one side of the light guide plate; and a film assembly comprising an optical film between the at least one support bar and the light guide plate, wherein the optical film is provided with at least one flange protruding from at least one side of the optical film assembly and over the at least one support portion on a surface of the at least one support portion facing the at least one support bar.

10  
**[007]** In some embodiments, the backlight assembly further comprises: a backplane with a bottom plate and at least one side plate surrounding the bottom plate; wherein each of the at least one side plate of the backplane comprises at least one slot configured to hold the at least one support portion and the at least one flange.

**[008]** In some embodiments, the at least one slot has a shape configured to fit with the at least one flange and the at least one support portion.

**[009]** In some embodiments, the shape of the at least one slot is rectangular.

**[010]** In some embodiments, the at least one flange of the optical film is over the at least one support portion via at least one shading tape.

25  
**[011]** In some embodiments, wherein each flange corresponds to one support portion.

**[012]** In some embodiments, a surface area of the support portion is no less than a surface area of the flange.

**[013]** In some embodiments, the surface area of the support portion equals the

surface area of the flange.

**[014]** In some embodiments, the at least one flange and the at least one support portion both have a substantially same shape.

5 **[015]** In some embodiments, the shape is one of rectangle, square, semicircle, or trapezoid.

**[016]** In some embodiments, the at least one support portion of the light guide plate is evenly spaced along each of the at least one side of the light guide plate.

10 **[017]** In some embodiments, the backplane has a U-shaped cross section; and the at least one support portion is over the at least one side plate of the backplane at an end surface facing the at least one support bar.

**[018]** In some embodiments, a side surface of a protruding end of the at least one support portion is aligned with an outer wall of the at least one side plate of the backplane.

15 **[019]** In some embodiments, the at least one support portion is mounted over the at least one side plate of the backplane via adhesive bonding.

**[020]** In some embodiments, the backplane and the frame are coupled via adhesive bonding.

**[021]** In some embodiments, the backplane and the frame are coupled via a double-sided adhesive tape.

20 **[022]** In some embodiments, the backplane and the frame are coupled via snap-fit connection.

**[023]** In some embodiments, the backplane and the frame are integrally formed.

**[024]** In some embodiments, the frame is formed by injection molding on the backplane.

25 **[025]** In another aspect, a display apparatus is provided, comprising the abovementioned backlight assembly.

**[026]** Other embodiments and implementations may become apparent in view of the following descriptions and the attached drawings.

## BRIEF DESCRIPTION OF THE DRAWINGS

[027] To more clearly illustrate some of the embodiments, the following is a brief description of the drawings. The drawings in the following descriptions are only illustrative of some embodiments. For those of ordinary skill in the art, without the premise of inventive efforts, other drawings of other embodiments can become apparent based on these drawings.

[028] FIG. 1 is a schematic diagram of a conventional backlight module with an optical film mounted under a frame.

[029] FIG. 2 is a schematic diagram of a structure of part of a backlight assembly according to some embodiments.

[030] FIG. 3 is a schematic diagram of a coupling between support portions of the light guide plate and the side plate of the backplane in the backlight assembly of FIG. 2.

[031] FIG. 4 is a schematic diagram of amounting structure of the optical film in a backlight assembly according to some other embodiments.

[032] FIG. 5 is a schematic diagram of the coupling of between the support portions of the light guide plate and the side plate of the backplane in the backlight assembly of FIG. 4.

## DETAILED DESCRIPTION

[033] In the following, with reference to the drawings of various embodiments disclosed herein, the technical solutions of the embodiments of the disclosure will be described in a clear and fully understandable way. It is obvious that the described embodiments are merely a portion but not all of the embodiments of the disclosure. Based on the described embodiments of the disclosure, those ordinarily skilled in the art can obtain other embodiment(s), which come(s) within the scope sought for protection by the disclosure.

**[034]** In a conventional backlight module, the relatively short distance between the edge of the light guide plate and the edge of the effective display area can result in issues such as shadowing and uneven lighting near the regions of mounting brackets. Dark stripes and bright spots may appear as a result. The conventional structure also makes it difficult to achieve narrow-border designs for the display apparatus.

**[035]** FIG. 1 illustrates a conventional backlight module with an optical film assembly 400 mounted under a frame 100. In this configuration, the frame 100 fastens a light guide plate 300 and the optical film assembly 400 underneath, and supports the display panel above the light guide plate 300.

**[036]** A backplane 200 is provided with a mounting bracket 220 on its sidewall, for mounting and positioning the film assembly 400. To support the mounting bracket 220, a backplane 200 is provided with a step 210. In order to make room for the step 210 and the mounting bracket 220 arranged on the backplane 200, the edge of light guide plate 300 needs to be close to the edge of the effective display area of the display apparatus. This can result in shadowing and uneven lighting near the regions of mounting brackets of the fixing structure, and make it difficult to achieve narrow-border designs for the display apparatus.

**[037]** To overcome at least some of the drawbacks in existing technologies, the present disclosure provides a backlight assembly including a fixing structure, and a display apparatus containing the backlight assembly. In the fixing structure, the film assembly is mounted via the light guide plate, which can alleviate the problems shadowing and uneven lighting, reduce the width of the support bar on the frame, and facilitate narrow-boarder designs for the display apparatus.

**[038]** Refer to FIGS. 2-5 for a fixing structure according to some embodiments of the disclosure. The fixing structure comprises a frame 1, a backplane 2, a light guide plate 3, and a film assembly 4. In some embodiments, the film assembly comprises an optical film or an optical diaphragm, for example when the fixing structure is configured as a backlight assembly of a display apparatus. The backlight assembly may also be referred to as a backlight module. The backlight

assembly can have a modular structure, or can comprise a plurality of components. The backlight assembly can also be provided as a kit including different components.

5 [039] The frame 1 can be provided with at least one support bar 11, configured to provide support to a display panel. The film assembly 4 is disposed between the at least one support bar 11 and the light guide plate 3, and at least one flange 41 is arranged on at least one side of the film assembly 4.

10 [040] In some embodiments, the fixing structure can be configured in a modular fashion and include different components. For example, the structure can be used as a backlight module for a display apparatus. In some embodiments, the structure can be used in other applications, such as securing a panel and providing mechanical support to the panel. The panel can be an electronic device, a piece of painting, or any other delicate structure that can be assembled and secured according to various embodiments disclosed herein.

15 [041] In some embodiments, the frame can be a mold frame, a plastic frame, or other frames known to those of ordinary skills in the art. In some embodiments, the flange 41 can be a rim, a protrusion, or have other shapes.

20 [042] The light guide plate 3 can be provided with at least one support portion 31. The at least one flange 41 of the film assembly 4 can be mounted on the at least one support portion 31 of the light guide plate 3 on a side facing the support bar 11 of the frame 1.

25 [043] As a result of the mounting of the flange 41 of the film assembly 4 on the support portion 31 of the light guide plate 3, the film assembly 4 can be mounted via the light guide plate 3. This configuration substantially eliminates the need for arranging mounting brackets and steps on the sidewall of the backplane, thereby reducing the distance from the light guide plate 3 and the film assembly 4 to the sidewall of the frame 1, allowing for a closer arrangement of the light guide plate 3 and the film assembly 4 to the sidewall of the frame 1.

30 [044] As such, the support bar 11 on the frame 1 can be configured to have a relatively small width in its shadowing of the edge of light guide plate 3, which can

reduce or eliminate the problems of shadowing and uneven lighting. In addition, reduction of the width (shown as “A” in FIGS. 2 and 4) of the support bar 11 of the frame 1 helps to achieve narrow-border designs for display apparatuses.

5 [045] In some embodiments, as shown in FIGS. 2 and 4, the at least one flange 41 of the film assembly 4 is attached via at least one shading tape 5 to the at least one support portion 31 of the light guide plate 3 on a side facing the support bar 11.

10 [046] In some embodiments, the flange 41 and the support portion 31 can both be shaped as rectangle, square, semicircle, or trapezoid, and can be configured to have the same shape, to facilitate mounting the at least one flange 41 of the film assembly 4 with the at least one support portion 31 of the light guide plate 3.

15 [047] In some embodiments, the film assembly 4 can be provided with a plurality of flanges 41. The light guide plate 3 can be provided with a plurality of support portions 31. The plurality of flanges 41 and the plurality of support portions 31 can have a one-to-one correspondence. For example, each flange 41 corresponds to one support portion 31, and each support portion 31 corresponds to one flange 41. The plurality of support portions 31 of the light guide plate 3 and the plurality of flanges 41 of the film assembly 4 can be coupled in one-to-one connections.

20 [048] For each connection between one support portion 31 and one flange 41, the support portion 31 can be configured to have a support surface having an area greater than, or equal to, an area of a matching surface of the flange 41, allowing for a sufficiently strong coupling between the matching surface of the flange 41 and the support surface of the support portion 31.

25 [049] In some embodiments, the film assembly 4 can have all four sides as mounting sides. In some other embodiments, the film assembly 4 can have a pair of opposite sides as mounting sides.

[050] In some embodiments, as shown in FIG. 3 and FIG. 5, the plurality of support portion 31 that correspond to each mounting side of the film assembly 4 can be evenly spaced along the mounting side.

[051] In some embodiments, as shown in FIG. 2 and FIG. 4, the fixing structure is

configured as part of a backlight assembly of a display apparatus. The backlight assembly comprises a frame 1, a backplane 2, a light guide plate 3, and a film assembly including the optical film 4. The frame 1 is provided with at least one support bar 11, configured to provide support to a display panel. The optical film 4 is disposed between the at least one support bar 11 and the light guide plate 3. At least one flange 41 is arranged on at least one side of the optical film 4. The light guide plate 3 is provided with at least one support portion 31. The at least one flange 41 of the optical film 4 is mounted on the at least one support portion 31 of the light guide plate 3 on a side facing the support bar 11 of the frame 1. The backplane 2 comprises a bottom plate 21 and at least one side plate 22 which surrounds the bottom plate 21, and the backplane 2 has a “U”-shaped cross section.

**[052]** In some embodiments, as shown in FIG. 4, each of the at least one support portion 31 is disposed over the end surface of the side plate 22 of the backplane 2 that corresponds to the support portion 31, and the support portion 31 and the side plate 22 can be connected via adhesive bonding.

**[053]** In some embodiments, as shown in FIG. 4 and FIG. 5, the protruding end of each of the at least one support portion 31 is configured to align with the outer wall of the side plate 22 of the backplane 2.

**[054]** In some embodiments, as shown in FIG. 2 and FIG. 3, the side plate 22 of the backplane 2 can be provided with at least one slot 23 corresponding to the at least one support portion 31. Each slot 23 can correspond to one support portion 31, and each support portion 31 can correspond to one slot 23.

**[055]** A protruding end of each of the at least one support portion 31 of the light guide plate 3, as well as each of the at least one flange 41 of the optical film 4, extends into each of the at least one slot 23 on the side plate 22 of the backplane 2. Such a configuration can simplify installation and mounting of the light guide plate 3, and constrain or limit movement of the light guide plate 3 and the optical film 4, thereby facilitating speed and efficiency of the assembly process.

**[056]** In some embodiments, to facilitate the extension of the at least one support portion 31 and the at least one flange 41 into the at least one slots 23 in a

corresponding manner, the at least one slot 23 can be arranged to have a rectangular shape that is fit with the at least one flange 41 and the at least one support portion 31.

5 [057] In some embodiments, the frame 1 and the backplane 2 in the backlight assembly as described above can be connected by bonding, as shown in FIG. 2 and FIG. 4, where the side plate 22 of the backplane 2 and the frame 1 can be bonded with a double-sided adhesive tape 6. In some other embodiments, the backplane 2 and the frame 1 can be coupled via a snap-fit connection. The backplane 2 and the frame 1 can also be integrally formed to be a one-piece structure; for example, 10 after the backplane 2 is manufactured, the frame 1 can be formed integrally by injection molding on the backplane 2.

[058] It should be noted that the various structural shapes, sizes, etc. described above in the various embodiments of the disclosure are only schematic and illustrative of the structures, and should not to be interpreted as limitations. In 15 practice, deviations introduced during manufacturing are within the scope of protection of this disclosure. For example, the rectangular, square, semi-circular, or trapezoidal shapes can have rounded corners, and can have variations in the lengths of sides and in their respective ratios. In some embodiments, the fixing structure or the backlight assembly can be provided as a kit of components, to be 20 assembled into the backlight assembly, and the display apparatus.

[059] Although specific embodiments have been described above in detail, the description is merely for purposes of illustration. It should be appreciated, therefore, that many aspects described above are not intended as required or essential elements unless explicitly stated otherwise. Various modifications of, 25 and equivalent acts corresponding to, the disclosed aspects of the exemplary embodiments, in addition to those described above, can be made by a person of ordinary skill in the art, having the benefit of the present disclosure, without departing from the spirit and scope of the disclosure defined in the following claims, the scope of which is to be accorded the broadest interpretation so as to 30 encompass such modifications and equivalent structures.

## CLAIMS

1. A backlight assembly, comprising:  
a frame with at least one support bar configured to support a display panel;  
5 a light guide plate with at least one support portion protruding from at least one side of the light guide plate; and  
a film assembly comprising an optical film between the at least one support bar and the light guide plate, wherein the optical film is provided with at least one flange protruding from at least one side of the optical film assembly and over the at least one  
10 support portion on a surface of the at least one support portion facing the at least one support bar.
2. The backlight assembly of Claim 1, further comprising:  
a backplane with a bottom plate and at least one side plate surrounding the bottom  
15 plate;  
wherein each of the at least one side plate of the backplane comprises at least one slot configured to hold the at least one support portion and the at least one flange.
3. The backlight assembly of Claim 2, wherein the at least one slot has a shape  
20 configured to fit with the at least one flange and the at least one support portion.
4. The backlight assembly of Claim 3, wherein the shape of the at least one slot is rectangular.
- 25 5. The backlight assembly of Claim 1, wherein the at least one flange of the optical film is over the at least one support portion via at least one shading tape.
6. The backlight assembly of Claim 1, wherein each flange corresponds to one support portion.
- 30 7. The backlight assembly of Claim 1, wherein a surface area of the support portion is no less than a surface area of the flange.

8. The backlight assembly of Claim 7, wherein the surface area of the support portion equals the surface area of the flange.
9. The backlight assembly of Claim 1, wherein the at least one flange and the at least one support portion both have a substantially same shape.
10. The backlight assembly of Claim 9, wherein the shape is one of rectangle, square, semicircle, or trapezoid.
11. The backlight assembly of Claim 1, wherein the at least one support portion of the light guide plate is evenly spaced along each of the at least one side of the light guide plate.
12. The backlight assembly of Claim 2, wherein:  
the backplane has a U-shaped cross section; and  
the at least one support portion is over the at least one side plate of the backplane at an end surface facing the at least one support bar.
13. The backlight assembly of Claim 12, wherein a side surface of a protruding end of the at least one support portion is aligned with an outer wall of the at least one side plate of the backplane.
14. The backlight assembly of Claim 13, wherein the at least one support portion is mounted over the at least one side plate of the backplane via adhesive bonding.
15. The backlight assembly of Claim 2, wherein the backplane and the frame are coupled via adhesive bonding.
16. The backlight assembly of Claim 15, wherein the backplane and the frame are coupled via a double-sided adhesive tape.
17. The backlight assembly of Claim 2, wherein the backplane and the frame are coupled via snap-fit connection.

18. The backlight assembly of Claim 2, wherein the backplane and the frame are integrally formed.

5 19. The backlight assembly of Claim 18, wherein the frame is formed by injection molding on the backplane.

20. A display apparatus, comprising the backlight assembly of any one of Claims 1-19.

10

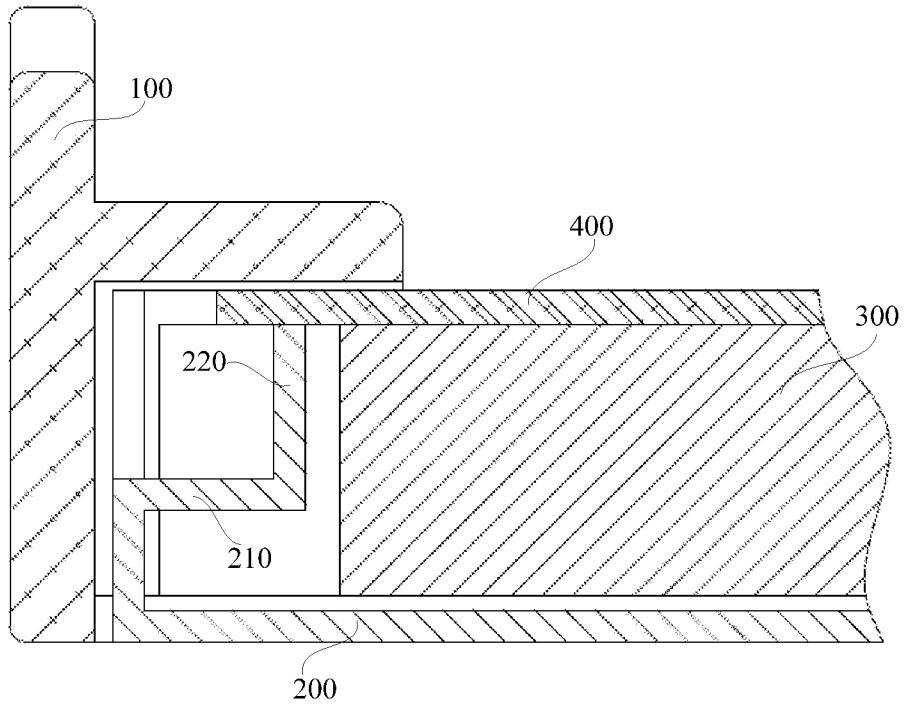

**FIG. 1 (Prior Art)**

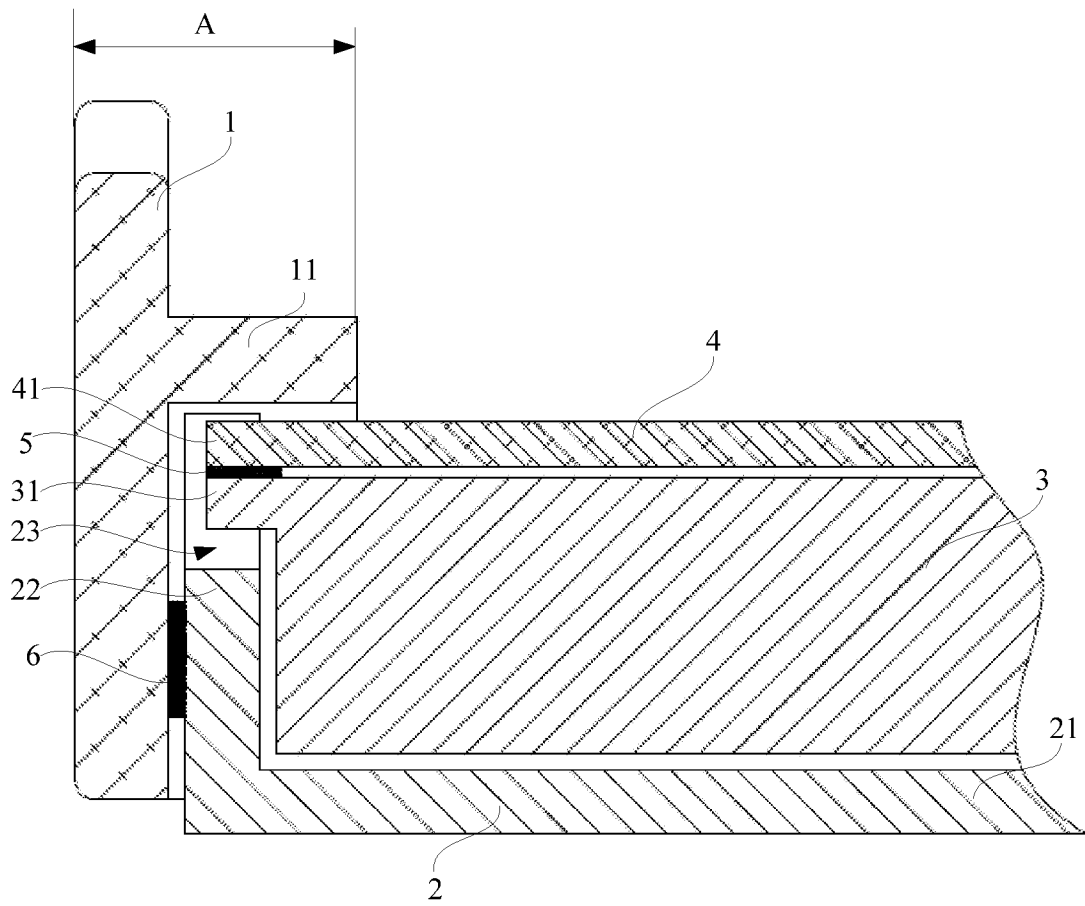
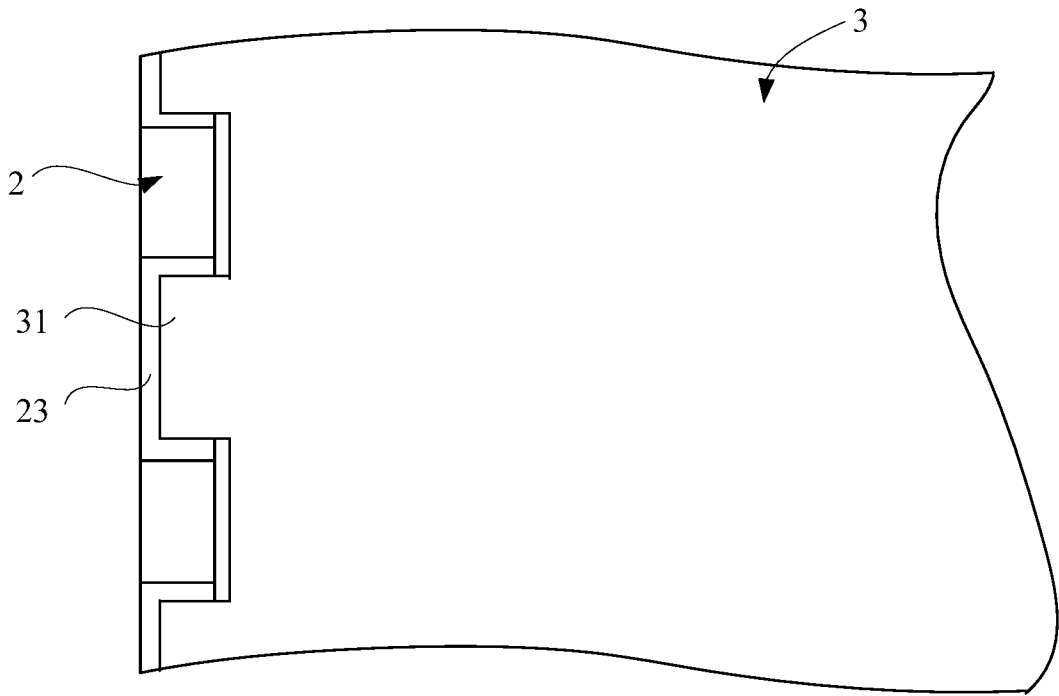

FIG. 2



**FIG. 3**

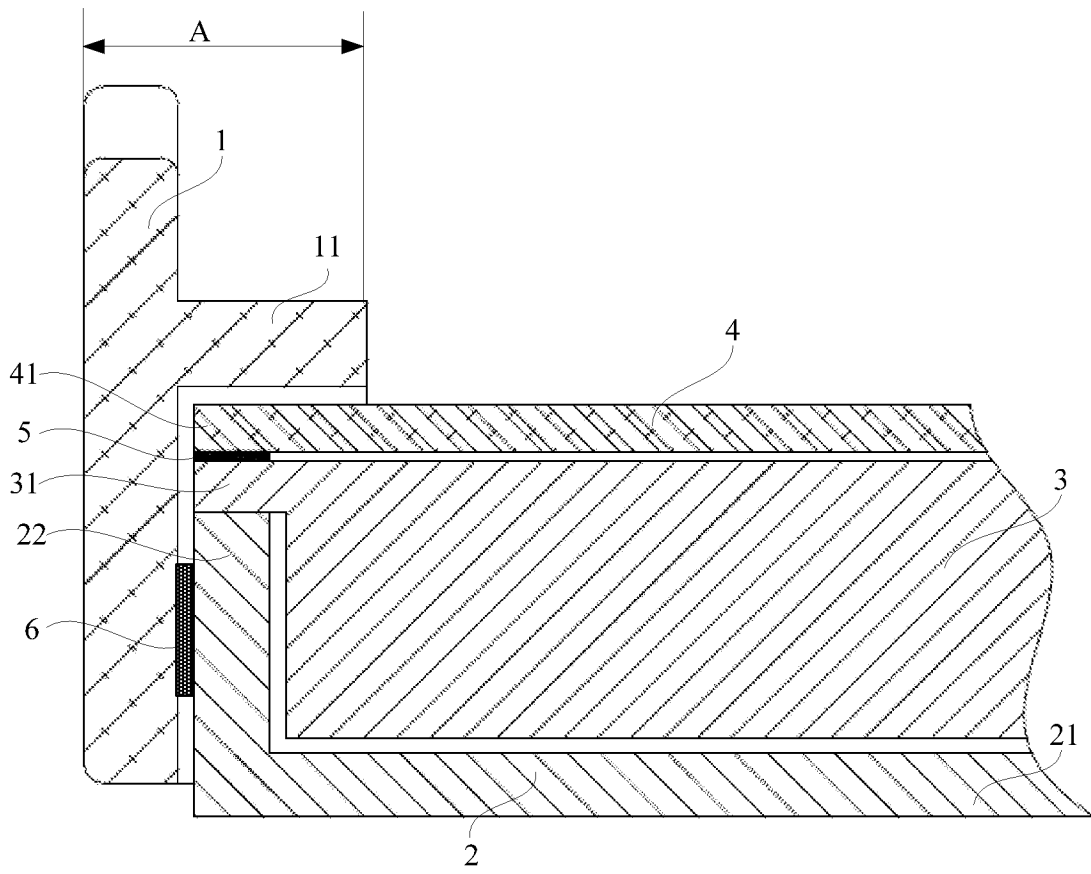

FIG. 4

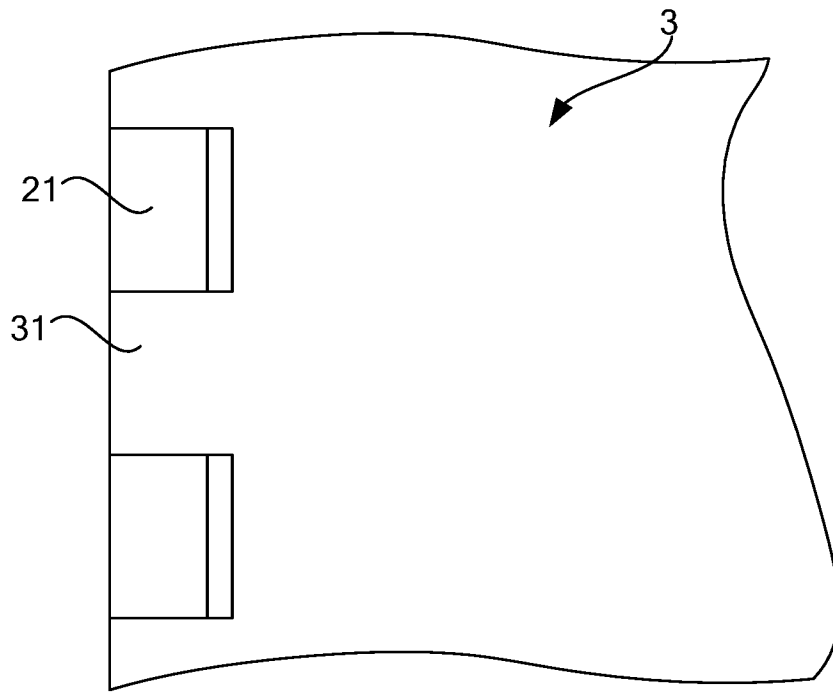

FIG. 5

## INTERNATIONAL SEARCH REPORT

International application No.

**PCT/CN2016/082900**

<b>A. CLASSIFICATION OF SUBJECT MATTER</b>		
G02F 1/1335(2006.01)i; G02F 1/1333(2006.01)i		
According to International Patent Classification (IPC) or to both national classification and IPC		
<b>B. FIELDS SEARCHED</b>		
Minimum documentation searched (classification system followed by classification symbols) G02F G09G G09F F21V F21S		
Documentation searched other than minimum documentation to the extent that such documents are included in the fields searched		
Electronic data base consulted during the international search (name of data base and, where practicable, search terms used) WUEC;CNABS;CNTXT;VEN;TWABS:LCD lightguide optical diffus+ protrud+ support+ superpos+ backplane backlight		
<b>C. DOCUMENTS CONSIDERED TO BE RELEVANT</b>		
Category*	Citation of document, with indication, where appropriate, of the relevant passages	Relevant to claim No.
Y	CN 202057922 U (SHENZHEN CHINA STAR OPTOELECTRONICS TECH) 30 November 2011 (2011-11-30) description, paragraphs [0021] to [0030] and figures 1-3	1-20
Y	CN 200972512 Y (SHENGHUA SCIENCE & TECHNOLOGY CO LTD) 07 November 2007 (2007-11-07) description, page 3, line 20 to page 6, line 9 and figures 2-11	1-20
PX	CN 205067925 U (BOECT TECHNOLOGY CO LTD ET AL.) 02 March 2016 (2016-03-02) the whole document	1-20
A	JP 2013186983 A (SHARP KK) 19 September 2013 (2013-09-19) the whole document	1-20
A	US 5923457 A (GENTEX CORP) 13 July 1999 (1999-07-13) the whole document	1-20
<input type="checkbox"/> Further documents are listed in the continuation of Box C. <input checked="" type="checkbox"/> See patent family annex.		
* Special categories of cited documents: "A" document defining the general state of the art which is not considered to be of particular relevance "E" earlier application or patent but published on or after the international filing date "L" document which may throw doubts on priority claim(s) or which is cited to establish the publication date of another citation or other special reason (as specified) "O" document referring to an oral disclosure, use, exhibition or other means "P" document published prior to the international filing date but later than the priority date claimed "T" later document published after the international filing date or priority date and not in conflict with the application but cited to understand the principle or theory underlying the invention "X" document of particular relevance; the claimed invention cannot be considered novel or cannot be considered to involve an inventive step when the document is taken alone "Y" document of particular relevance; the claimed invention cannot be considered to involve an inventive step when the document is combined with one or more other such documents, such combination being obvious to a person skilled in the art "&" document member of the same patent family		
Date of the actual completion of the international search <b>19 August 2016</b>		Date of mailing of the international search report <b>31 August 2016</b>
Name and mailing address of the ISA/CN <b>STATE INTELLECTUAL PROPERTY OFFICE OF THE P.R.CHINA 6, Xitucheng Rd., Jimen Bridge, Haidian District, Beijing 100088 China</b>		Authorized officer <b>XIE,Fei</b>
Facsimile No. <b>(86-10)62019451</b>		Telephone No. <b>(86-10)62089907</b>

**INTERNATIONAL SEARCH REPORT**  
**Information on patent family members**

International application No.

**PCT/CN2016/082900**

Patent document cited in search report			Publication date (day/month/year)	Patent family member(s)			Publication date (day/month/year)
CN	202057922	U	30 November 2011	US	8558963	B2	15 October 2013
				WO	2012145956	A1	01 November 2012
				US	2013208208	A1	15 August 2013
				US	2012152982	A1	21 June 2012
CN	200972512	Y	07 November 2007	None			
CN	205067925	U	02 March 2016	None			
JP	2013186983	A	19 September 2013	JP	5931512	B2	08 June 2016
US	5923457	A	13 July 1999	None			