



(11) **EP 2 241 830 A3**

(12) **EUROPEAN PATENT APPLICATION**

(88) Date of publication A3:
30.04.2014 Bulletin 2014/18

(51) Int Cl.:
F24F 1/00 (2011.01)

(43) Date of publication A2:
20.10.2010 Bulletin 2010/42

(21) Application number: **10001910.8**

(22) Date of filing: **22.02.2010**

(84) Designated Contracting States:
AT BE BG CH CY CZ DE DK EE ES FI FR GB GR HR HU IE IS IT LI LT LU LV MC MK MT NL NO PL PT RO SE SI SK SM TR
Designated Extension States:
AL BA RS

(71) Applicant: **Mitsubishi Electric Corporation**
Tokyo 100-8310 (JP)

(72) Inventor: **Adachi, Yusuke**
Tokyo 100-8310 (JP)

(30) Priority: **31.03.2009 JP 2009084746**

(74) Representative: **Pfenning, Meinig & Partner GbR**
Patent- und Rechtsanwälte
Theresienhöhe 13
80339 München (DE)

(54) **Outdoor unit of air conditioner**

(57) There is provided an outdoor unit in which high operation reliability is ensured by cooling a heat sink having heat radiation fins effectively, and preventing damages of a power module due to heat. An outdoor unit 1 includes a partition plate 3 provided upright so as to extend from a bottom plate 2 of the outdoor unit 1 to halfway to a top thereof; an electric component box 14 placed on the partition plate 3 and configured to divide the interior of the outdoor unit into a machinery chamber M and a heat exchanger chamber H in cooperation with the partition plate; an electronic substrate 13 stored in the electric component box; a compressor 4 provided in the machinery chamber; a propeller fan 6 and a heat exchanger 5 provided in the heat exchanger chamber; in which an electric component partition plate 15 configured to divide the interior of the electric component box and the heat exchanger chamber is inclined so that an extended line thereof toward a front surface of the outdoor unit intersects a line of projection of a front edge of a vane 12 of the propeller fan, the electronic substrate is fixed to the electric component partition plate, a heat sink 17 being in contact with the back side of the electronic substrate is fixed to extend in parallel to the electric component partition plate, a plurality of heat radiation fins 16 are formed on one surface of the heat sink so as to project therefrom toward the heat exchanger chamber and extend in parallel to a flow of air on the electric component partition plate.

FIG. 1

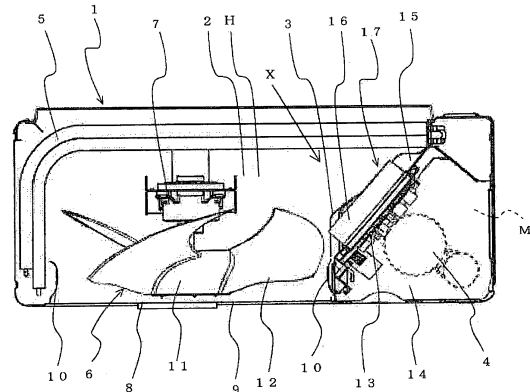

ANNEX TO THE EUROPEAN SEARCH REPORT
ON EUROPEAN PATENT APPLICATION NO.

EP 10 00 1910

This annex lists the patent family members relating to the patent documents cited in the above-mentioned European search report. The members are as contained in the European Patent Office EDP file on
The European Patent Office is in no way liable for these particulars which are merely given for the purpose of information.

26-03-2014

Patent document cited in search report		Publication date	Patent family member(s)	Publication date
EP 1956310	A1	13-08-2008	AU 2006309660 A1	10-05-2007
			CN 101297162 A	29-10-2008
			EP 1956310 A1	13-08-2008
			JP 3985835 B2	03-10-2007
			JP 2007127380 A	24-05-2007
			KR 20080068092 A	22-07-2008
			US 2009122499 A1	14-05-2009
			WO 2007052786 A1	10-05-2007

WO 2006054547	A1	26-05-2006	NONE	

JP H1026372	A	27-01-1998	NONE	

JP H09287778	A	04-11-1997	JP 3047810 B2	05-06-2000
			JP H09287778 A	04-11-1997

JP H09236286	A	09-09-1997	JP 3039360 B2	08-05-2000
			JP H09236286 A	09-09-1997

EP 1684023	A1	26-07-2006	AU 2004280422 A1	21-04-2005
			CN 1864036 A	15-11-2006
			EP 1684023 A1	26-07-2006
			JP 3698152 B2	21-09-2005
			JP 2005114244 A	28-04-2005
			KR 20060060049 A	02-06-2006
			US 2007006610 A1	11-01-2007
			WO 2005036064 A1	21-04-2005

EPO FORM P0459

For more details about this annex : see Official Journal of the European Patent Office, No. 12/82