



- (51) International Patent Classification: Not classified
- (21) International Application Number: PCT/IN2013/000271
- (22) International Filing Date: 22 April 2013 (22.04.2013)
- (25) Filing Language: English
- (26) Publication Language: English
- (30) Priority Data: 1598/CHE/2012 23 April 2012 (23.04.2012) IN
- (71) Applicant: EKO TECHNOLOGIES LIMITED [IN/IN]; #504,Trendset Towers,Road No.2, Banjara Hills, Hyderabad 500034 (IN).
- (72) Inventor: N.S., Chandrasekhar; #504,Trendset Towers,Road No.2, Banjara Hills, Hyderabad 500034 (IN).

KR, KZ, LA, LC, LK, LR, LS, LT, LU, LY, MA, MD, ME, MG, MK, MN, MW, MX, MY, MZ, NA, NG, NI, NO, NZ, OM, PA, PE, PG, PH, PL, PT, QA, RO, RS, RU, RW, SC, SD, SE, SG, SK, SL, SM, ST, SV, SY, TH, TJ, TM, TN, TR, TT, TZ, UA, UG, US, UZ, VC, VN, ZA, ZM, ZW.

(84) Designated States (unless otherwise indicated, for every kind of regional protection available): ARIPO (BW, GH, GM, KE, LR, LS, MW, MZ, NA, RW, SD, SL, SZ, TZ, UG, ZM, ZW), Eurasian (AM, AZ, BY, KG, KZ, RU, TJ, TM), European (AL, AT, BE, BG, CH, CY, CZ, DE, DK, EE, ES, FI, FR, GB, GR, HR, HU, IE, IS, IT, LT, LU, LV, MC, MK, MT, NL, NO, PL, PT, RO, RS, SE, SI, SK, SM, TR), OAPI (BF, BJ, CF, CG, CI, CM, GA, GN, GQ, GW, ML, MR, NE, SN, TD, TG).

Declarations under Rule 4.17:

- as to the identity of the inventor (Rule 4.17(i))
- as to applicant's entitlement to apply for and be granted a patent (Rule 4.17(ii))
- of inventorship (Rule 4.17(iv))

Published:

- without international search report and to be republished upon receipt of that report (Rule 48.2(g))

- (81) Designated States (unless otherwise indicated, for every kind of national protection available): AE, AG, AL, AM, AO, AT, AU, AZ, BA, BB, BG, BH, BN, BR, BW, BY, BZ, CA, CH, CL, CN, CO, CR, CU, CZ, DE, DK, DM, DO, DZ, EC, EE, EG, ES, FI, GB, GD, GE, GH, GM, GT, HN, HR, HU, ID, IL, IN, IS, JP, KE, KG, KM, KN, KP,

(54) Title: SYSTEM AND METHOD FOR CONCENTRATING SOLAR RAYS TO GENERATE SOLAR POWER

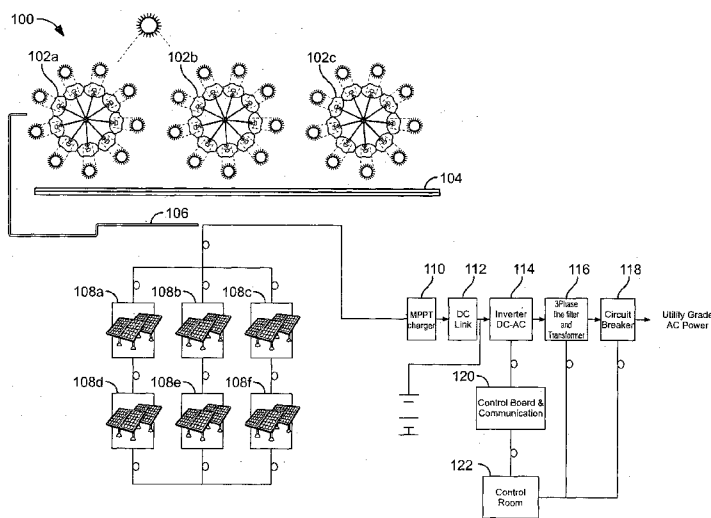

(57) Abstract: A system and a method for concentrating solar rays to generate solar power are disclosed. The system includes multiple optical cassegrain lens vertically and horizontally mounted in a stable tubular structure and configured to concentrate solar rays, a mirror positioned below the tubular structure for enabling the plurality of optical lenses to integrate direct sun rays, diffused sun rays and reflected sunrays. The system further includes multiple solar panels vertically stacked in a secured environment to receive the solar rays concentrated by the multiple optical cassegrain lens for generating a solar power, optical fiber cables connected between the plurality of optical compound lens and the plurality of solar panels for routing the concentrated solar rays and a charger connected to the plurality of solar panels for driving the generated solar power.



TECHNICAL FIELD OF THE INVENTION

[0001] The present invention generally relates to a solar power generating systems. More particularly, the present invention relates to a system and method for concentrating solar rays to generate solar power.

Background of the invention

[0002] In general there are many sources of generating electricity from natural resources such as wind systems, solar systems and the like. Them the most easily available source for generating electricity is solar power which uses the heat or light sources for supporting the life on the earth by generating electricity. Moreover, in recent years there has been a phenomenal advance in manufacturing new solar power generation plants.

[0003] Conventionally, there exist various types of apparatuses for gathering sunlight. There are different types of light conducting sections for guiding the gathered sunlight to the green houses and residences, one among them which is most frequently used in conventional solar power generation means was through ducts. But using ducts as a light conducting means is very complicated process especially for installing it in the building it costs a lot and also destroys a portion of the building. Hence the current technology generates solar power by illuminating the solar cells and thus generating power. This solution calls for large area of solar farm where the solar PV panels (both conventional and concentrated) are deployed in the fields and power is generated. In the case of concentrated solar power the lense and PV cell track the sun movement over the day, also some cases over the year by means of active single axis /two axis trackers.

[0004] Typically, to overcome the above mentioned problem of light conducting means an optical fiber cable is later used as the other guiding means for generating solar power without any destruction. Further conventional method used for gathering sunlight include placing panels on the roof top of a building for collecting large amount of sunlight and transferring it to the invertors and batteries by a wired medium through an optical fiber cable for generating solar power.

[0005] Conventional, methods for generating solar power mostly use the concentrated photo voltaic technology by the illuminated solar cells in the photovoltaic array. The conventional PV systems are pointed directly to the sun, because they work by focusing sunlight onto a targeted area for generating power in fixed inclinations and therefore require trackers to follow the sun's trajectory throughout the day. The flat-plate solar panels covers the entire surface with costly semiconductor material and the most efficient silicon panels require semiconductor material twice the area of an entire PV system to provide an equivalent amount of power. Thus by exposing panels to the direct sunlight, life time of the panels is very low and the amount of power generated in convention methods has low efficiency and also the above mentioned convention method lags in concentrating the solar radiations emitted from the sun light in all directions.

[0006] In the light of aforementioned limitations, there exists a need for an enhanced technology which concentrates the solar radiations in all the 360 directions for generating by increasing the intensity of the received solar energy.

Brief Summary of the Invention

[0007] the following presents a simplified summary of the disclosure in order to provide a basic understanding to the reader. This summary is not an extensive overview of the disclosure and it does not identify key/critical elements of the invention or delineate the scope of the invention. Its sole purpose is to present some concepts disclosed herein in a simplified form as a prelude to the more detailed description that is presented later.

[0008] Amore complete appreciation of the present invention and the scope thereof can be obtained from the accompanying drawings which are briefly summarized below and the following detailed description of the presently preferred embodiments.

[0009] In accordance with a non limiting exemplary aspect, this proposed technology uses relatively inexpensive optics such as mirrors and lenses to focus light from a broad collection area onto a smaller area.

[0010] An exemplary embodiment of the invention is to generate at least 5 to 50 times more solar power compared to conventional photovoltaic technology.

[0011] An exemplary embodiment of the invention is to have long life of power generation by a semiconductor surface area which is about one 10 to 50 times greater than that of 'one-sun' flat-plate panels composed of silicon solar cells.

[0012] An exemplary embodiment of the invention is to store solar panels inside a building in a conditioned vertically stacked environment to reduce the cost of maintenance and space (real estate).

[0013] An exemplary embodiment of the invention uses a cassegrain which is an inexpensive optics to drastically reduce the amount of expensive semiconductor material needed to produce each watt of electricity. In the cassegrain lenses are used to collect the sunlight and concentrate it to 50 to 100 times of its usual intensity onto conventional solar PV panels which are vertically stacked, under a thermally controlled environment.

[0014] An exemplary embodiment of the invention provides higher efficiencies and lower overall system costs than traditional photovoltaic system in sunny and dry climates.

[0015] An exemplary embodiment of the invention provides modular and seamlessly expandable growth potential in conventional photovoltaic technology.

[0016] A system and a method for concentrating solar rays to generate solar power are disclosed. According to a first aspect, the system includes a plurality of optical compound lens vertically and horizontally mounted in a stable triangular and tubular structure and configured to concentrate solar rays. The plurality of optical cassegrain lens includes an octagonal panel or a cylindrical panel and the like configured to capturing solar rays in 360 degrees.

[0017] According to the first aspect, the system includes a mirror positioned below the tubular structure for enabling the plurality of optical lenses to integrate a plurality of direct sun rays, a plurality of diffused sun rays and a plurality of reflected sun rays.

[0018] According to the first aspect, the system includes a plurality of solar panels vertically stacked in a secured environment to receive the solar rays concentrated by the plurality of optical cassegrain expander lens for generating a solar power.

[0019] According to the first aspect, the system includes a plurality of optical fiber cables connected between the plurality of optical cassegrain lens and the plurality of solar panels for routing the concentrated solar rays. The system further includes a beam coupler positioned between the array of fiber optic cables and the solar panel to compensate a transmission loss in the plurality of fiber optic cables

[0020] According to the first aspect, the system includes at least one charger connected to the plurality of solar panels for driving the generated solar power.

[0021] According to the first aspect, the system includes at least one or more Maximum power point charger connected to the plurality of solar panels and the battery/ Load for driving the generated solar power.

[0022] According to a second aspect, a method for concentrating solar rays to generate solar power is disclosed. The method includes concentrating a plurality of integrated solar rays by a plurality of vertically and horizontally mounted optical cassegrain lens. The plurality of cassegrain lens mounted on a stable tabular structure.

[0023] According to the second aspect, the method includes integrating incident solar rays, diffused solar rays and reflected rays by placing a mirror below the stable tabular structure for concentrating the plurality of optical cassegrain lens.

[0024] According to the second aspect, the method includes routing the concentrated solar rays through a plurality of optical fiber cables for transmitting to a plurality of solar panels vertically stacked in a secured environment. The plurality of solar panels generates a solar power utilizing the concentrated rays. The step of routing the concentrated solar rays includes a step of redistributing the concentrated rays to the plurality of solar panels.

[0025] According to the second aspect, the method further includes a step of charging the at least one maximum power point charger with the generated solar power.

Brief Description of the Drawings

[0026] Other objects and advantages of the present invention will become apparent to those skilled in the art upon reading the following detailed description of the preferred embodiments, in conjunction with the accompanying drawings, wherein like reference numerals have been used to designate like elements, and wherein:

[0027] FIG.1 is a diagram depicting an overview of a system for concentrating solar rays to generate solar power

[0028] FIG.2 is a diagram depicting a combination of an optical compound lens and a mirror for integrating the solar rays.

[0029] FIG.3 is a diagram depicting configuration of compound lens in a cassegrain configuration for concentrating the solar radiations.

[0030] FIG.4 is a diagram depicting a combination of multiple fiber optic cables connected to multiple beam connectors for transmitting the concentrated solar rays to the multiple solar panels.

Detail description of the invention

[0031] It is to be understood that the present disclosure is not limited in its application to the details of construction and the arrangement of components set forth in the following description or illustrated in the drawings. The present disclosure is capable of other embodiments and of being practiced or of being carried out in various ways. Also, it is to be understood that the phraseology and terminology used herein is for the purpose of description and should not be regarded as limiting.

[0032] The use of “including”, “comprising” or “having” and variations thereof herein is meant to encompass the items listed thereafter and equivalents thereof as well as additional items. The terms “a” and “an” herein do not denote a limitation of quantity, but rather denote the presence of at least one of the referenced item. Further, the use of terms “first”, “second”, and “third”, and the like, herein do not denote any order, quantity, or importance, but rather are used to distinguish one element from another.

[0033] Referring to FIG.1 is a diagram 100 depicting an overview of a system for concentrating solar rays to generate solar power. According to a non-limiting exemplary embodiment of the present subjectmatter, the system includes an array of individual focused lens 102a, 102b and 102c positioned over a mirror 104, multiple solar panels 108a, 108b, 1008c, 108d, 108e and 108f and a fiber optic cable 106 acts as a guiding means for transmitting or routing the concentrated solar rays to the solar panels 108a, 108b, 1008c, 108d, 108e and 108f to generate solar power.

[0034] In accordance with a non-limiting exemplary implementation of the present subject matter, the optical compound lenses 102a, 102b and 102c are arranged in a cassegrain configuration on a tubular structure and positioned vertically and horizontally on the rooftop of a building. The array of individual focused lens 102a, 102b and 102c are positioned over a mirror 104 for concentrating the direct, diffused and reflected rays in all directions i.e., in 360 degrees. The concentrated solar rays are guided through a flexible light pipes such as an optical fiber cable 106 and the like and transmitted to the multiple solar panels 108a, 108b, 1008c, 108d, 108e and 108f. The multiple solar panels 108a, 108b, 1008c, 108d, 108e and 108f are vertically stacked in a cool protected place and positioned inside a building in a controlled environment.

[0035] According to a non-limiting exemplary implementation of the present subject matter, the solar panels 108a, 108b, 1008c, 108d, 108e and 108f are coupled to a maximum power point tracking charger also referred as MPPT charger 110 for tracking the maximum power from the solar panels 108a, 108b, 1008c, 108d, 108e and 108f. The power tracked by the MPPT charger 110 is transmitted to a DC link 112 which is further connected to an inverter 114 for converting DC power to AC. The converted AC power is transmitted to a control room 122 through a control board communication device 120 or a 3 phase line filter and transformer 116, where the control board 120 consists of switches and dials for controlling the electrical devices in a building. A circuit breaker module 118 can also be placed between the 3 phase line filter 116 and control room 122 for transmitting converted AC power and this module 118 is used for controlling the automatically operated switches from damage caused by overload. The modules 116, 118 and 120 connected between the inverter 114 and control room 122 for compensating the transmission loss of solar power.

[0036] Referring to FIG.2 is a diagram 200 depicting a combination of an optical compound lens and a mirror for integrating the solar rays. According to a non limiting exemplary embodiment of the present subjectmatter, the system includes an optical compound lens 202 positioned above the mirror 204 on the rooftop of a building.

[0037] In accordance with a non-limiting exemplary implementation of the present subject matter, the system includes an optical compound lens 202 which can be octagonal or cylindrical and are vertically and horizontally mounted on the roof top of a building for concentrating solar rays. A mirror 204 is positioned at the bottom of the optical compound lens 202 for concentrating the directed, diffused and reflected solar rays in all directions i.e., in 360 degrees. The concentrated solar rays are guided through an optical fiber cable and the like to the multiple solar panels which are vertically stacked and positioned inside a building in a controlled environment for generating solar power.

[0038] Referring to FIG.3 is a diagram 300 depicting configuration of compound lens in a cassegrain configuration for concentrating the solar radiations. According to a non-limiting exemplary embodiment of the present subjectmatter, the system includes an individual focused lens 302 in an array positioned above the mirror 304 and a fiber optic cable 306 serving as a guiding means between the each individual focused lens and a solar panel.

[0039] In accordance with a non-limiting exemplary implementation of the present subject matter, the system includes an individual focused lens 302 configured in a cassegrain configuration on a tubular structure and are vertically and horizontally mounted on the rooftop of a building. A mirror 304 is positioned at the bottom of the array of individual focused lens for concentrating the directed, diffused and reflected rays in all directions i.e., in 360 degrees. The concentrated solar rays of each individual focused lens 302 are guided through an each optical fiber cable 306 to one or more solar panels and the array of focused lens are guided by the multiple optical fiber cables for transmitting the concentrated solar rays to the multiple solar panels.

[0040] Referring to FIG.4 is a diagram 400 depicting a combination of multiple fiber optic cables connected to multiple beam connectors for transmitting the concentrated solar rays to the multiple solar panels. According to a non limiting exemplary embodiment of the present subjectmatter, the system includes multiple fiber optic cables 402 connected to a beam connector 404 for transmitting the concentrated solar rays to a solar panel 406.

[0041] In accordance with a non-limiting exemplary implementation of the present subject matter, the system includes the multiple fiber optic cables 402 configured to act as a guiding or routing medium between the optical compound lens and a solar panel 406 for transmitting the concentrated solar rays. The concentrated beam transmitted in the optical fiber cable 402 is combined through a branch or stem of a other concentrated beam known as beam connector 404 which is used for compensating the transmission loss in the fiber optic cable 402. The beam connectors 404 are further connected to vertically stacked solar panels which are positioned inside a building in a controlled environment. The solar rays transmitted to the solar panels 406 are further connected to the MPPT charger for tracking maximum power from panels and generating solar power in a building.

[0042] While specific embodiments of the invention have been shown and described in detail to illustrate the inventive principles, it will be understood that the invention may be embodied otherwise without departing from such principles.

Claims:

1. A system for concentrating solar rays to generate solar power, the system comprising:
 - a plurality of optical compound lens vertically and horizontally mounted in a stable tubular structure and configured to concentrate solar rays;
 - a mirror positioned below the tubular structure for enabling the plurality of optical lenses to integrate a plurality of direct sun rays, a plurality of diffused sun rays and a plurality of reflected sunrays;
 - a plurality of solar panels vertically stacked in a secured environment to receive the solar rays concentrated by the plurality of optical compound lens for generating a solar power; and
 - an array of a plurality of optical fiber cables connected between the plurality of optical compound lens and the plurality of solar panels for routing the concentrated solar rays; and at least one charger connected to the plurality of solar panels for driving the generated solar power;
2. The system of claim 1, wherein the plurality of optical cassegrain lense comprising at least one of: an octagonal panel; and a cylindrical panel; configured to capturing solar rays in 360 degrees.
3. The system of claim 1 further comprising a plurality of concentrating adaptors for converging the concentrated solar rays converges to the plurality of solar panels.
4. The system of claim 1, wherein at least one beam connector positioned between the array of the plurality of optical fiber cables and the solar panel to compensate a transmission loss in the plurality of fiber optic cables.
5. The system of claim 1, wherein the at least one charger connected to an inverter.

6. A method for integrating concentrated solar rays to generate solar power comprising:

concentrating a plurality of integrated solar rays by a plurality of vertically and horizontally mounted optical compound lens, whereby the plurality of compound lens mounted on a stable tabular structure;

integrating a plurality of incident solar rays; a plurality of direct solar rays and a plurality of reflected compound rays by placing a mirror below the stable tabular structure for concentrating the plurality of optical cassegrain lense; and

routing the concentrated solar rays through an array of a plurality of optical fiber cables for transmitting to a plurality of solar panels vertically stacked in a secured environment, whereby the plurality of solar panels generate a solar power utilizing the concentrated rays.

7. The method of claim 6, wherein the step of routing the concentrated solar rays comprising a step of re distributing the concentrated rays to the plurality of solar panels.
8. The method of claim 6 further comprising a step of charging the at least one charger with the generated solar power.
9. The method of claim 6 further comprising a step of redistributing the completely captured solar rays to each individual panel by a plurality of optical fiber cables.
10. The method of claim 6 further comprising a step of converging the concentrated solar rays converges to the plurality of solar panels through a plurality of concentrating adaptors.

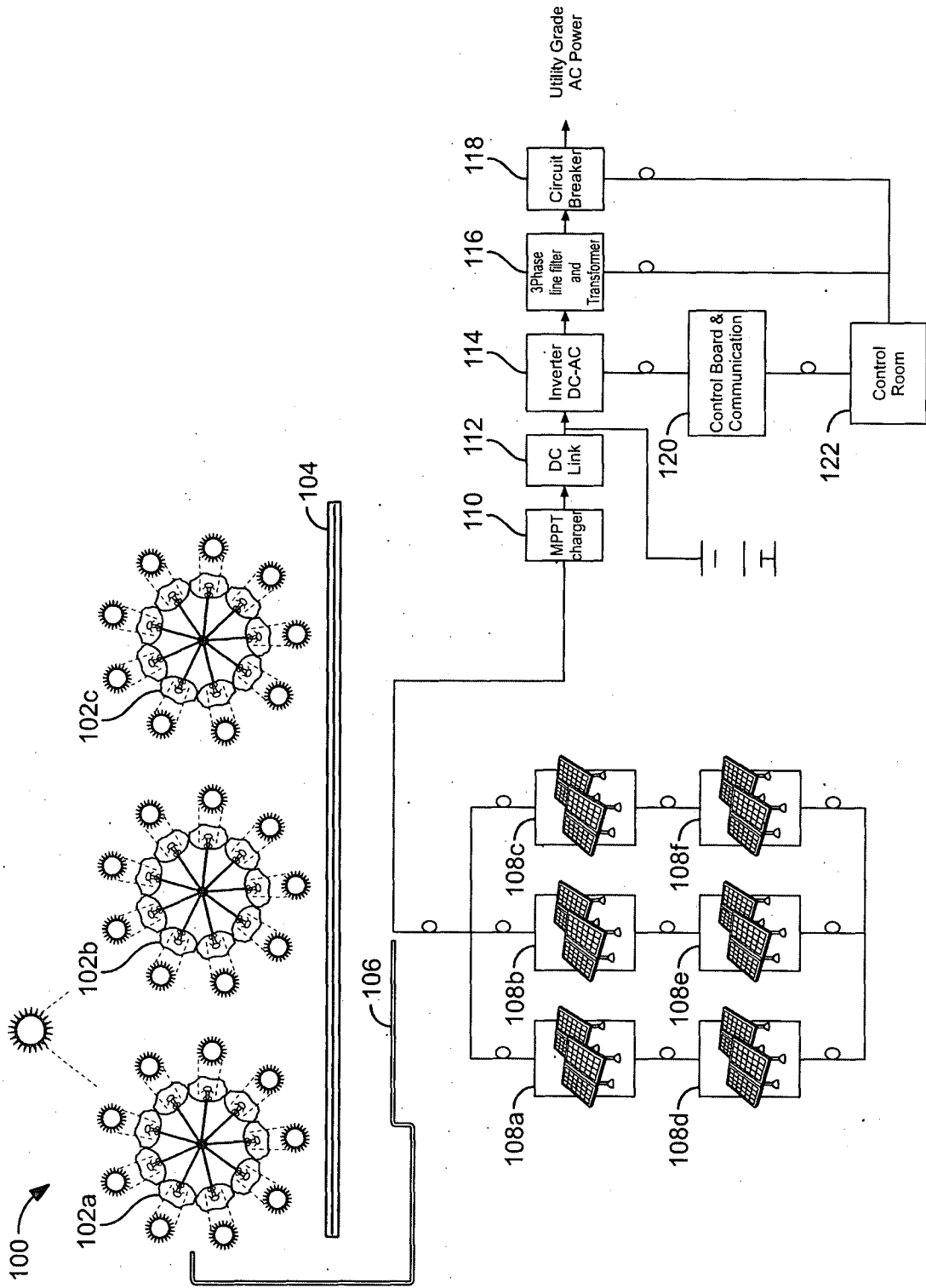

FIG. 1

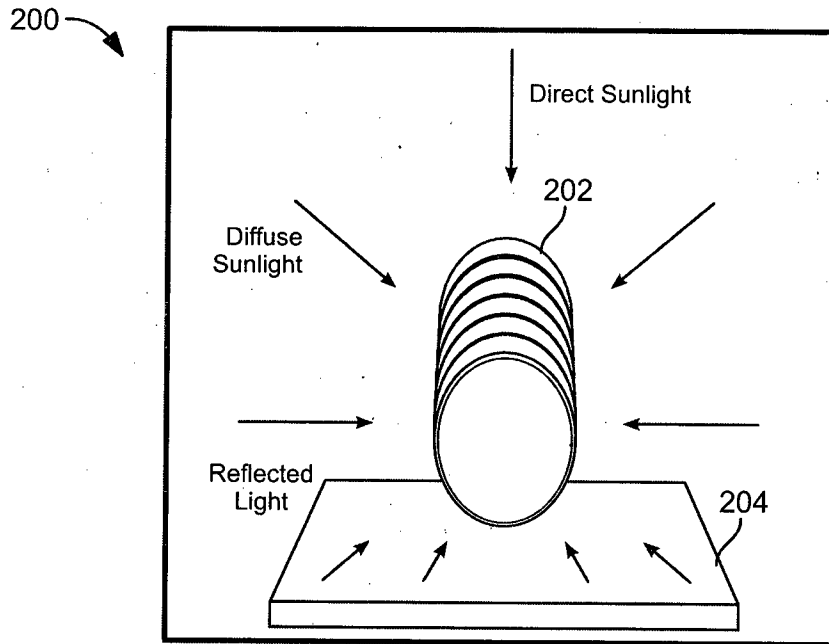

FIG. 2

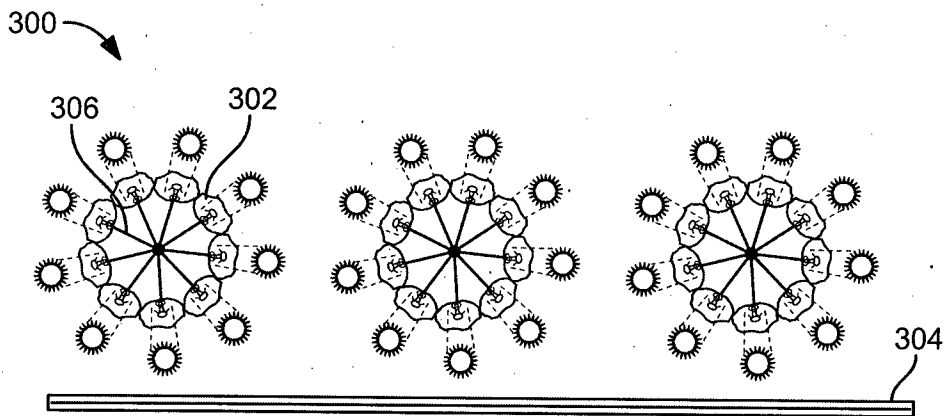

FIG. 3

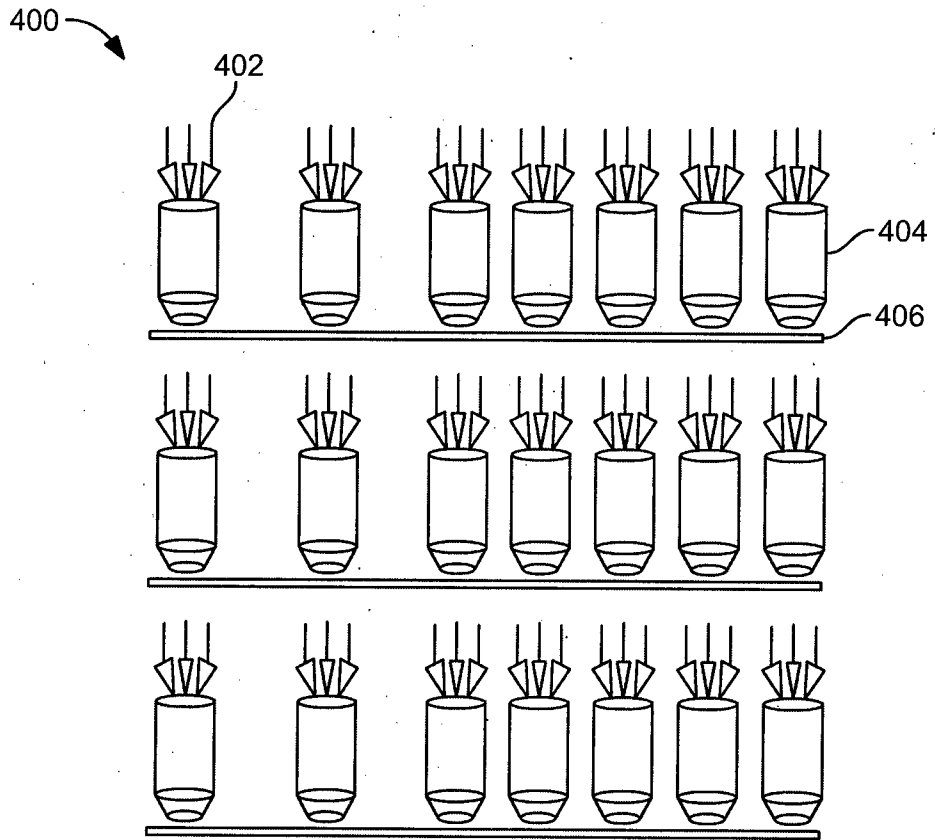

FIG. 4