

(19) World Intellectual Property Organization
International Bureau



(43) International Publication Date
20 January 2005 (20.01.2005)

PCT

(10) International Publication Number
WO 2005/006808 A1

(51) International Patent Classification⁷: H04R 3/00,
G10L 21/02

SPRIET, Ann [BE/BE]; Nieuwstraat 20, B-8870 IZEGEM (BE). MOONEN, Marc [BE/BE]; Termeredellelaan 7, B-3020 HERENT/WINKSELE (BE). WOUTERS, Jan [BE/BE]; Leming 125, B-3320 HOLSBEEK (BE).

(21) International Application Number:
PCT/BE2004/000103

(74) Agents: VAN MALDEREN, Eric et al.; OFFICE VAN MALDEREN, Place Reine Fabiola 6/1, B-1083 BRUXELLES (BE).

(22) International Filing Date: 12 July 2004 (12.07.2004)

(25) Filing Language: English

(81) Designated States (unless otherwise indicated, for every kind of national protection available): AE, AG, AL, AM, AT, AU, AZ, BA, BB, BG, BR, BW, BY, BZ, CA, CH, CN, CO, CR, CU, CZ, DE, DK, DM, DZ, EC, EE, EG, ES, FI, GB, GD, GE, GH, GM, HR, HU, ID, IL, IN, IS, JP, KE, KG, KP, KR, KZ, LC, LK, LR, LS, LT, LU, LV, MA, MD, MG, MK, MN, MW, MX, MZ, NA, NI, NO, NZ, OM, PG, PH, PL, PT, RO, RU, SC, SD, SE, SG, SK, SL, SY, TJ, TM, TN, TR, TT, TZ, UA, UG, US, UZ, VC, VN, YU, ZA, ZM, ZW.

(26) Publication Language: English

(30) Priority Data:
2003903575 11 July 2003 (11.07.2003) AU
2004901931 8 April 2004 (08.04.2004) AU

(71) Applicant (for all designated States except US): COCHLEAR LIMITED [AU/AU]; 14-16, Mars Road, LANE COVE, New South Wales 2066 (AU).

(84) Designated States (unless otherwise indicated, for every kind of regional protection available): ARIPO (BW, GH, GM, KE, LS, MW, MZ, NA, SD, SL, SZ, TZ, UG, ZM, ZW), Eurasian (AM, AZ, BY, KG, KZ, MD, RU, TJ, TM),

(72) Inventors; and

(75) Inventors/Applicants (for US only): DOCLO, Simon [BE/BE]; Groene Wandeling 19, B-2970 SCHILDE (BE).

[Continued on next page]

(54) Title: METHOD AND DEVICE FOR NOISE REDUCTION

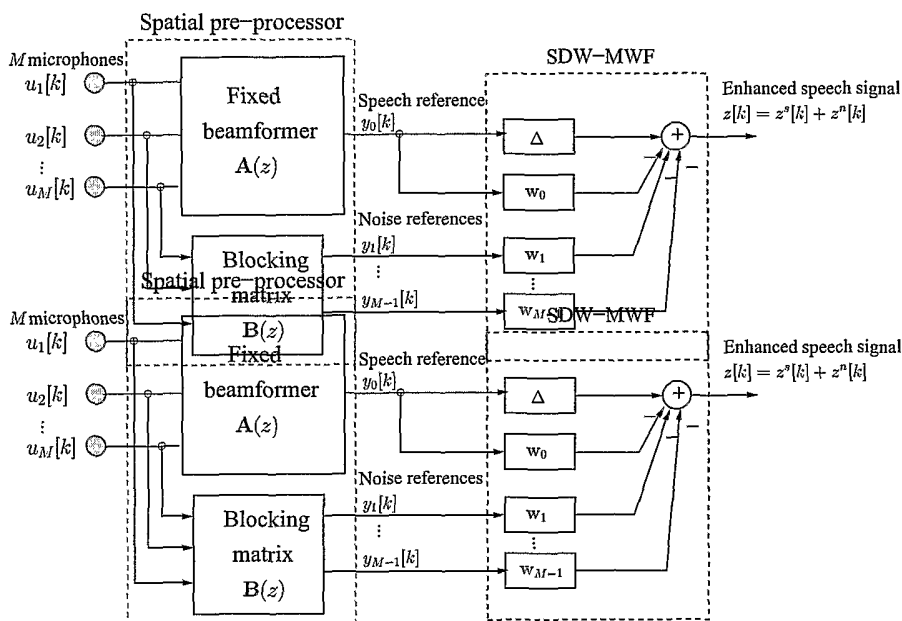

(57) Abstract: The present invention is related to a method to reduce noise in a noisy speech signal, comprising the steps of - applying at least two versions of the noisy speech signal to a first filter. The first filter outputs a speech reference signal and at least one noise reference signal, - applying a filtering operation to each of the at least one noise reference signals, and - subtracting from the speech reference signal each of the filtered noise reference signals. The filtering operation is performed with filters having filter coefficients determined by taking into account speech leakage contributions in the at least one noise reference signal.

WO 2005/006808 A1



European (AT, BE, BG, CH, CY, CZ, DE, DK, EE, ES, FI, FR, GB, GR, HU, IE, IT, LU, MC, NL, PL, PT, RO, SE, SI, SK, TR), OAPI (BF, BJ, CF, CG, CI, CM, GA, GN, GQ, GW, ML, MR, NE, SN, TD, TG).

— *before the expiration of the time limit for amending the claims and to be republished in the event of receipt of amendments*

Published:

— *with international search report*

For two-letter codes and other abbreviations, refer to the "Guidance Notes on Codes and Abbreviations" appearing at the beginning of each regular issue of the PCT Gazette.

5

METHOD AND DEVICE FOR NOISE REDUCTION

Field of the invention

10 [0001] The present invention is related to a method and device for adaptively reducing the noise in speech communication applications.

State of the art

15 [0002] In speech communication applications, such as teleconferencing, hands-free telephony and hearing aids, the presence of background noise may significantly reduce the intelligibility of the desired speech signal. Hence, the use of a noise reduction algorithm is necessary. Multi-
20 microphone systems exploit spatial information in addition to temporal and spectral information of the desired signal and noise signal and are thus preferred to single microphone procedures. Because of aesthetic reasons, multi-microphone techniques for e.g., hearing aid applications go
25 together with the use of small-sized arrays. Considerable noise reduction can be achieved with such arrays, but at the expense of an increased sensitivity to errors in the assumed signal model such as microphone mismatch, reverberation, ... (see e.g. *Stadler & Rabinowitz, 'On the
30 potential of fixed arrays for hearing aids', J. Acoust. Soc. Amer., vol. 94, no. 3, pp. 1332-1342, Sep. 1993*) In hearing aids, microphones are rarely matched in gain and phase. Gain and phase differences between microphone

characteristics can amount up to 6 dB and 10°, respectively.

[0003] A widely studied multi-channel adaptive noise reduction algorithm is the *Generalised Sidelobe Canceller* (GSC) (see e.g. *Griffiths & Jim, 'An alternative approach to linearly constrained adaptive beamforming', IEEE Trans. Antennas Propag., vol. 30, no. 1, pp. 27-34, Jan. 1982* and *US-5473701 'Adaptive microphone array'*). The GSC consists of a fixed, spatial pre-processor, which includes a fixed beamformer and a blocking matrix, and an adaptive stage based on an Adaptive Noise Canceller (ANC). The ANC minimises the output noise power while the blocking matrix should avoid speech leakage into the noise references. The standard GSC assumes the desired speaker location, the microphone characteristics and positions to be known, and reflections of the speech signal to be absent. If these assumptions are fulfilled, it provides an undistorted enhanced speech signal with minimum residual noise. However, in reality these assumptions are often violated, resulting in so-called speech leakage and hence speech distortion. To limit speech distortion, the ANC is typically adapted during periods of noise only. When used in combination with small-sized arrays, e.g., in hearing aid applications, an additional robustness constraint (see *Cox et al., 'Robust adaptive beamforming', IEEE Trans. Acoust. Speech and Signal Processing', vol. 35, no. 10, pp. 1365-1376, Oct. 1987*) is required to guarantee performance in the presence of small errors in the assumed signal model, such as microphone mismatch. A widely applied method consists of imposing a Quadratic Inequality Constraint to the ANC (QIC-GSC). For Least Mean Squares (LMS) updating, the Scaled Projection Algorithm (SPA) is a simple and effective technique that imposes this constraint. However,

using the QIC-GSC goes at the expense of less noise reduction.

- [0004] A *Multi-channel Wiener Filtering* (MWF) technique has been proposed (see *Doclo & Moonen, 'GSVD-based optimal filtering for single and multimicrophone speech enhancement', IEEE Trans. Signal Processing, vol. 50, no. 9, pp. 2230-2244, Sep. 2002*) that provides a Minimum Mean Square Error (MMSE) estimate of the desired signal portion in one of the received microphone signals.
- 10 In contrast to the ANC of the GSC, the MWF is able to take speech distortion into account in its optimisation criterion, resulting in the *Speech Distortion Weighted Multi-channel Wiener Filter* (SDW-MWF). The (SDW-)MWF technique is uniquely based on estimates of the second
- 15 order statistics of the recorded speech signal and the noise signal. A robust speech detection is thus again needed. In contrast to the GSC, the (SDW-)MWF does not make any a priori assumptions about the signal model such that no or a less severe robustness constraint is needed to
- 20 guarantee performance when used in combination with small-sized arrays. Especially in complicated noise scenarios such as multiple noise sources or diffuse noise, the (SDW-)MWF outperforms the GSC, even when the GSC is supplemented with a robustness constraint.
- 25 [0005] A possible implementation of the (SDW-)MWF is based on a *Generalised Singular Value Decomposition* (GSVD) of an input data matrix and a noise data matrix. A cheaper alternative based on a *QR Decomposition* (QRD) has been proposed in *Rombouts & Moonen, 'QRD-based unconstrained*
- 30 *optimal filtering for acoustic noise reduction', Signal Processing, vol. 83, no. 9, pp. 1889-1904, Sep. 2003.* Additionally, a subband implementation results in improved intelligibility at a significantly lower cost compared to the fullband approach. However, in contrast to the GSC and

the QIC-GSC, no cheap stochastic gradient based implementation of the (SDW-)MWF is available yet. In Nordholm et al., 'Adaptive microphone array employing calibration signals: an analytical evaluation', *IEEE Trans. Speech, Audio Processing*, vol. 7, no. 3, pp. 241-252, May 1999, an LMS based algorithm for the MWF has been developed. However, said algorithm needs recordings of calibration signals. Since room acoustics, microphone characteristics and the location of the desired speaker change over time, frequent re-calibration is required, making this approach cumbersome and expensive. Also an LMS based SDW-MWF has been proposed that avoids the need for calibration signals (see Florencio & Malvar, 'Multichannel filtering for optimum noise reduction in microphone arrays', *Int. Conf. on Acoust., Speech, and Signal Proc., Salt Lake City, USA*, pp. 197-200, May 2001). This algorithm however relies on some independence assumptions that are not necessarily satisfied, resulting in degraded performance.

[0006] The GSC and MWF techniques are now presented more in detail.

Generalised Sidelobe Canceller (GSC)

[0007] Fig. 1 describes the concept of the Generalised Sidelobe Canceller (GSC), which consists of a fixed, spatial pre-processor, i.e. a fixed beamformer $A(z)$ and a blocking matrix $B(z)$, and an ANC. Given M microphone signals

$$u_i[k] = u_i^s[k] + u_i^n[k], \quad i=1, \dots, M \quad (\text{equation 1})$$

with $u_i^s[k]$ the desired speech contribution and $u_i^n[k]$ the noise contribution, the fixed beamformer $A(z)$ (e.g. delay-and-sum) creates a so-called speech reference

$$y_0[k] = y_0^s[k] + y_0^n[k], \quad (\text{equation 2})$$

by steering a beam towards the direction of the desired signal, and comprising a speech contribution $y_0^s[k]$ and a noise contribution $y_0^n[k]$. The blocking matrix $B(z)$ creates
 5 $M-1$ so-called noise references

$$y_i[k] = y_i^s[k] + y_i^n[k], \quad i=1, \dots, M-1 \quad (\text{equation 3})$$

by steering zeroes towards the direction of the desired signal source such that the noise contributions $y_i^n[k]$ are dominant compared to the speech leakage contributions $y_i^s[k]$.
 10 In the sequel, the superscripts s and n are used to refer to the speech and the noise contribution of a signal. During periods of speech + noise, the references $y_i[k]$, $i=0 \dots M-1$ contain speech + noise. During periods of noise only, the references only consist of a noise component,
 15 i.e. $y_i[k] = y_i^n[k]$. The second order statistics of the noise signal are assumed to be quite stationary such that they can be estimated during periods of noise only.

[0008] To design the fixed, spatial pre-processor, assumptions are made about the microphone characteristics,
 20 the speaker position and the microphone positions and furthermore reverberation is assumed to be absent. If these assumptions are satisfied, the noise references do not contain any speech, i.e., $y_i^s[k] = 0$, for $i=1, \dots, M-1$. However, in practice, these assumptions are often violated (e.g. due
 25 to microphone mismatch and reverberation) such that speech leaks into the noise references. To limit the effect of such speech leakage, the ANC filter $\mathbf{w}_{1:M-1} \in C^{(M-1)L \times 1}$

$$\mathbf{w}_{1:M-1}^H = [\mathbf{w}_1^H \quad \mathbf{w}_2^H \quad \dots \quad \mathbf{w}_{M-1}^H] \quad (\text{equation 4})$$

where

$$30 \quad \mathbf{w}_i = [w_i[0] \quad w_i[1] \quad \dots \quad w_i[L-1]]^T, \quad (\text{equation 5})$$

with L the filter length, is adapted during periods of noise only. (Note that in a time-domain implementation the input signals of the adaptive filter $\mathbf{w}_{1:M-1}$ and the filter $\mathbf{w}_{1:M-1}$ are real. In the sequel the formulas are generalised to complex input signals such that they can also be applied to a subband implementation.) Hence, the ANC filter $\mathbf{w}_{1:M-1}$ minimises the output noise power, i.e.

$$\mathbf{w}_{1:M-1} = \arg \min_{\mathbf{w}_{1:M-1}} E \left\{ \left| y_0^n[k-\Delta] - \mathbf{w}_{1:M-1}^H[k] \mathbf{y}_{1:M-1}^n[k] \right|^2 \right\} \quad (\text{equation 6})$$

leading to

$$\mathbf{w}_{1:M-1} = E \left\{ \mathbf{y}_{1:M-1}^n[k] \mathbf{y}_{1:M-1}^{n,H}[k] \right\}^{-1} E \left\{ \mathbf{y}_{1:M-1}^n[k] y_0^{n,*}[k-\Delta] \right\}, \quad (\text{equation 7})$$

where

$$\mathbf{y}_{1:M-1}^{n,H}[k] = \left[y_1^{n,H}[k] \quad y_2^{n,H}[k] \quad \dots \quad y_{M-1}^{n,H}[k] \right] \quad (\text{equation 8})$$

$$\mathbf{y}_i^n[k] = \left[y_i^n[k] \quad y_i^n[k-1] \quad \dots \quad y_i^n[k-L+1] \right]^T \quad (\text{equation 9})$$

and where Δ is a delay applied to the speech reference to allow for non-causal taps in the filter $\mathbf{w}_{1:M-1}$. The delay Δ is usually set to $\lceil \frac{L}{2} \rceil$, where $\lceil x \rceil$ denotes the smallest integer equal to or larger than x . The subscript $1:M-1$ in $\mathbf{w}_{1:M-1}$ and $\mathbf{y}_{1:M-1}$ refers to the subscripts of the first and the last channel component of the adaptive filter and input vector, respectively.

[0009] Under ideal conditions ($y_i^s[k]=0, i=1, \dots, M-1$), the GSC minimises the residual noise while not distorting the desired speech signal, i.e. $z^s[k]=y_0^s[k-\Delta]$. However, when used in combination with small-sized arrays, a small error in the assumed signal model (resulting in $y_i^s[k] \neq 0, i=1, \dots, M-1$) already suffices to produce a significantly distorted output speech signal $z^s[k]$

$$z^s[k] = y_0^s[k-\Delta] - \mathbf{w}_{1:M-1}^H \mathbf{y}_{1:M-1}^s[k], \quad (\text{equation 10})$$

even when only adapting during noise-only periods, such that a robustness constraint on $\mathbf{w}_{1:M-1}$ is required. In

addition, the fixed beamformer $A(z)$ should be designed such that the distortion in the speech reference $y_0^s[k]$ is minimal for all possible model errors. In the sequel, a delay-and-sum beamformer is used. For small-sized arrays, this
 5 beamformer offers sufficient robustness against signal model errors, as it minimises the noise sensitivity. The noise sensitivity is defined as the ratio of the spatially white noise gain to the gain of the desired signal and is often used to quantify the sensitivity of an algorithm
 10 against errors in the assumed signal model. When statistical knowledge is given about the signal model errors that occur in practice, the fixed beamformer and the blocking matrix can be further optimised.

[0010] A common approach to increase the robustness
 15 of the GSC is to apply a Quadratic Inequality Constraint (QIC) to the ANC filter $\mathbf{w}_{1:M-1}$, such that the optimisation criterion (eq.6) of the GSC is modified into

$$\mathbf{w}_{1:M-1} = \arg \min_{\mathbf{w}_{1:M-1}} E \left\{ \left| y_0^n[k-\Delta] - \mathbf{w}_{1:M-1}^H[k] \mathbf{y}_{1:M-1}^n[k] \right|^2 \right\} \quad (\text{equation 11})$$

subject to $\mathbf{w}_{1:M-1}^H \mathbf{w}_{1:M-1} \leq \beta^2$.

The QIC avoids excessive growth of the filter coefficients
 20 $\mathbf{w}_{1:M-1}$. Hence, it reduces the undesired speech distortion when speech leaks into the noise references.

The QIC-GSC can be implemented using the adaptive *scaled projection algorithm (SPA)*: at each update step, the quadratic constraint is applied to the newly obtained ANC
 25 filter by scaling the filter coefficients by $\frac{\beta}{\|\mathbf{w}_{1:M-1}\|}$ when $\mathbf{w}_{1:M-1}^H \mathbf{w}_{1:M-1}$ exceeds β^2 . Recently, Tian et al. implemented the quadratic constraint by using variable loading ('Recursive least squares implementation for LCMP Beamforming under quadratic constraint', *IEEE Trans. Signal Processing*, vol. 49, no. 6, pp. 1138-1145, June 2001). For Recursive Least
 30 Squares (RLS), this technique provides a better

approximation to the optimal solution (eq.11) than the scaled projection algorithm.

Multi-Channel Wiener Filtering (MWF)

5

[0011] The Multi-channel Wiener filtering (MWF) technique provides a Minimum Mean Square Error (MMSE) estimate of the desired signal portion in one of the received microphone signals. In contrast to the GSC, this
10 filtering technique does not make any a priori assumptions about the signal model and is found to be more robust. Especially in complex noise scenarios such as multiple noise sources or diffuse noise, the MWF outperforms the GSC, even when the GSC is supplied with a robustness
15 constraint.

[0012] The MWF $\bar{\mathbf{w}}_{1:M} \in C^{ML \times 1}$ minimises the Mean Square Error (MSE) between a delayed version of the (unknown) speech signal $u_i^s[k-\Delta]$ at the i -th (e.g. first) microphone and the sum $\bar{\mathbf{w}}_{1:M}^H \mathbf{u}_{1:M}[k]$ of the M filtered microphone signals,
20 i.e.

$$\bar{\mathbf{w}}_{1:M} = \arg \min_{\bar{\mathbf{w}}_{1:M}} E \left\{ \left| u_i^s[k-\Delta] - \bar{\mathbf{w}}_{1:M}^H \mathbf{u}_{1:M}[k] \right|^2 \right\}, \quad (\text{equation 12})$$

leading to

$$\bar{\mathbf{w}}_{1:M} = E \{ \mathbf{u}_{1:M}[k] \mathbf{u}_{1:M}^H[k] \}^{-1} E \{ \mathbf{u}_{1:M}[k] u_i^{s,*}[k-\Delta] \}, \quad (\text{equation 13})$$

with

$$\bar{\mathbf{w}}_{1:M}^H = \left[\bar{\mathbf{w}}_1^H \quad \bar{\mathbf{w}}_2^H \quad \text{L} \quad \bar{\mathbf{w}}_M^H \right], \quad (\text{equation 14})$$

$$\mathbf{u}_{1:M}^H[k] = \left[\mathbf{u}_1^H[k] \quad \mathbf{u}_2^H[k] \quad \text{L} \quad \mathbf{u}_M^H[k] \right], \quad (\text{equation 15})$$

$$\mathbf{u}_i[k] = \left[u_i[k] \quad u_i[k-1] \quad \text{L} \quad u_i[k-L+1] \right]^T. \quad (\text{equation 16})$$

where $u_i[k]$ comprise a speech component and a noise component.

[0013] An equivalent approach consists in estimating a delayed version of the (unknown) noise signal $u_i^n[k-\Delta]$ in the i -th microphone, resulting in

$$\mathbf{w}_{1:M} = \arg \min_{\mathbf{w}_{1:M}} E \left\{ \left| u_i^n[k-\Delta] - \mathbf{w}_{1:M}^H \mathbf{u}_{1:M}[k] \right|^2 \right\}, \text{ (equation 17)}$$

5 and

$$\mathbf{w}_{1:M} = E \{ \mathbf{u}_{1:M}[k] \mathbf{u}_{1:M}^H[k] \}^{-1} E \{ \mathbf{u}_{1:M}[k] u_i^{s,*}[k-\Delta] \}, \text{ (equation 18)}$$

where

$$\mathbf{w}_{1:M}^H = \left[\mathbf{w}_1^H \quad \mathbf{w}_2^H \quad \dots \quad \mathbf{w}_M^H \right]. \text{ (equation 19)}$$

The estimate $z[k]$ of the speech component $u_i^s[k-\Delta]$ is then
 10 obtained by subtracting the estimate $\mathbf{w}_{1:M}^H \mathbf{u}_{1:M}[k]$ of $u_i^n[k-\Delta]$ from the delayed, i -th microphone signal $u_i[k-\Delta]$, i.e.

$$z[k] = u_i[k-\Delta] - \mathbf{w}_{1:M}^H \mathbf{u}_{1:M}[k]. \text{ (equation 20)}$$

This is depicted in Fig. 2 for $u_i^n[k-\Delta] = u_i^n[k-\Delta]$.

[0014] The residual error energy of the MWF equals

15
$$E \{ |e[k]|^2 \} = E \left\{ \left| u_i^s[k-\Delta] - \bar{\mathbf{w}}_{1:M}^H \mathbf{u}_{1:M}[k] \right|^2 \right\}, \text{ (equation 21)}$$

and can be decomposed into

$$E \left\{ \left| u_i^s[k-\Delta] - \bar{\mathbf{w}}_{1:M}^H \mathbf{u}_{1:M}^s[k] \right|^2 \right\} + E \left\{ \left| \bar{\mathbf{w}}_{1:M}^H \mathbf{u}_{1:M}^n[k] \right|^2 \right\} \text{ (equation 22)}$$

ε_d^2 ε_n^2

where ε_d^2 equals the speech distortion energy and ε_n^2 the residual noise energy. The design criterion of the MWF can
 20 be generalised to allow for a trade-off between speech distortion and noise reduction, by incorporating a weighting factor μ with $\mu \in [0, \infty]$

$$\bar{\mathbf{w}}_{1:M} = \arg \min_{\bar{\mathbf{w}}_{1:M}} E \left\{ \left| u_i^s[k-\Delta] - \bar{\mathbf{w}}_{1:M}^H \mathbf{u}_{1:M}^s[k] \right|^2 \right\} + \mu E \left\{ \left| \bar{\mathbf{w}}_{1:M}^H \mathbf{u}_{1:M}^n[k] \right|^2 \right\}. \text{ (equation 23)}$$

The solution of (eq.23) is given by

25
$$\bar{\mathbf{w}}_{1:M} = E \left\{ \mathbf{u}_{1:M}^s[k] \mathbf{u}_{1:M}^{s,H}[k] + \mu \mathbf{u}_{1:M}^n[k] \mathbf{u}_{1:M}^{n,H}[k] \right\}^{-1} E \left\{ \mathbf{u}_{1:M}^s[k] u_i^{s,*}[k-\Delta] \right\}. \text{ (equation 24)}$$

[0015] Equivalently, the optimisation criterion for $\mathbf{w}_{1:M-1}$ in (eq.17) can be modified into

$$\mathbf{w}_{1:M} = \arg \min_{\mathbf{w}_{1:M}} E \left\{ \left| \mathbf{w}_{1:M}^H \mathbf{u}_{1:M}^s[k] \right|^2 \right\} + \mu E \left\{ \left| u_i^n[k-\Delta] - \mathbf{w}_{1:M}^H \mathbf{u}_{1:M}^n[k] \right|^2 \right\}, \quad (\text{equation 25})$$

resulting in

$$\mathbf{w}_{1:M} = E \left\{ \mathbf{u}_{1:M}^n[k] \mathbf{u}_{1:M}^{n,H}[k] + \frac{1}{\mu} \mathbf{u}_{1:M}^s[k] \mathbf{u}_{1:M}^{s,H}[k] \right\}^{-1} E \left\{ \mathbf{u}_{1:M}^n[k] u_i^{n,*}[k-\Delta] \right\}. \quad (\text{equation 26})$$

In the sequel, (eq.26) will be referred to as the *Speech*
 5 *Distortion Weighted* Multi-channel Wiener Filter (SDW-MWF).

The factor $\mu \in [0, \infty]$ trades off speech distortion versus noise reduction. If $\mu=1$, the MMSE criterion (eq.12) or (eq.17) is obtained. If $\mu>1$, the residual noise level will be reduced at the expense of increased speech distortion.

10 By setting μ to ∞ , all emphasis is put on noise reduction and speech distortion is completely ignored. Setting μ to 0 on the other hand, results in no noise reduction.

[0016] In practice, the correlation matrix $E \left\{ \mathbf{u}_{1:M}^s[k] \mathbf{u}_{1:M}^{s,H}[k] \right\}$ is unknown. During periods of speech, the
 15 inputs $u_i[k]$ consist of speech + noise, i.e., $u_i[k] = u_i^s[k] + u_i^n[k], i=1, \dots, M$. During periods of noise, only the noise component $u_i^n[k]$ is observed. Assuming that the speech signal and the noise signal are uncorrelated, $E \left\{ \mathbf{u}_{1:M}^s[k] \mathbf{u}_{1:M}^{s,H}[k] \right\}$ can be estimated as

$$20 \quad E \left\{ \mathbf{u}_{1:M}^s[k] \mathbf{u}_{1:M}^{s,H}[k] \right\} = E \left\{ \mathbf{u}_{1:M}[k] \mathbf{u}_{1:M}^H[k] \right\} - E \left\{ \mathbf{u}_{1:M}^n[k] \mathbf{u}_{1:M}^{n,H}[k] \right\}, \quad (\text{equation 27})$$

where the second order statistics $E \left\{ \mathbf{u}_{1:M}[k] \mathbf{u}_{1:M}^H[k] \right\}$ are estimated during speech + noise and the second order statistics $E \left\{ \mathbf{u}_{1:M}^n[k] \mathbf{u}_{1:M}^{n,H}[k] \right\}$ during periods of noise only. As for the GSC, a robust speech detection is thus needed.

25 Using (eq.27), (eq.24) and (eq.26) can be re-written as:

$$\begin{aligned} \bar{\mathbf{w}}_{1:M} = & \left(E \left\{ \mathbf{u}_{1:M}[k] \mathbf{u}_{1:M}^H[k] \right\} + (\mu-1) E \left\{ \mathbf{u}_{1:M}^n[k] \mathbf{u}_{1:M}^{n,H}[k] \right\} \right)^{-1} \\ & \times \left(E \left\{ \mathbf{u}_{1:M}[k] u_i^{n,*}[k-\Delta] \right\} - E \left\{ \mathbf{u}_{1:M}^n[k] u_i^{n,*}[k-\Delta] \right\} \right) \end{aligned} \quad (\text{equation 28})$$

$$\text{and } \mathbf{w}_{1:M} = \left(\frac{1}{\mu} E\{\mathbf{u}_{1:M}[k]\mathbf{u}_{1:M}^H[k]\} + \left(1 - \frac{1}{\mu}\right) E\{\mathbf{u}_{1:M}^n[k]\mathbf{u}_{1:M}^{n,H}[k]\} \right)^{-1} E\{\mathbf{u}_{1:M}^n[k]u_i^{n,*}[k-\Delta]\}.$$

(equation 29)

The Wiener filter may be computed at each time instant k by means of a Generalised Singular Value Decomposition (GSVD) of a speech + noise and noise data matrix. A cheaper recursive alternative based on a QR-decomposition is also available. Additionally, a subband implementation increases the resulting speech intelligibility and reduces complexity, making it suitable for hearing aid applications.

Aims of the invention

[0017] The present invention aims to provide a method and device for adaptively reducing the noise, especially the background noise, in speech enhancement applications, thereby overcoming the problems and drawbacks of the state-of-the-art solutions.

Summary of the invention

[0018] The present invention relates to a method to reduce noise in a noisy speech signal, comprising the steps of

- applying at least two versions of the noisy speech signal to a first filter, whereby that first filter outputs a speech reference signal and at least one noise reference signal,
- applying a filtering operation to each of the at least one noise reference signals, and
- subtracting from the speech reference signal each of the filtered noise reference signals,

characterised in that the filtering operation is performed with filters having filter coefficients determined by

taking into account speech leakage contributions in the at least one noise reference signal.

[0019] In a typical embodiment the at least two versions of the noisy speech signal are signals from at least two microphones picking up the noisy speech signal.

[0020] Preferably the first filter is a spatial pre-processor filter, comprising a beamformer filter and a blocking matrix filter.

[0021] In an advantageous embodiment the speech reference signal is output by the beamformer filter and the at least one noise reference signal is output by the blocking matrix filter.

[0022] In a preferred embodiment the speech reference signal is delayed before performing the subtraction step.

[0023] Advantageously a filtering operation is additionally applied to the speech reference signal, where the filtered speech reference signal is also subtracted from the speech reference signal.

[0024] In another preferred embodiment the method further comprises the step of regularly adapting the filter coefficients. Thereby the speech leakage contributions in the at least one noise reference signal are taken into account or, alternatively, both the speech leakage contributions in the at least one noise reference signal and the speech contribution in the speech reference signal.

[0025] The invention also relates to the use of a method to reduce noise as described previously in a speech enhancement application.

[0026] In a second object the invention also relates to a signal processing circuit for reducing noise in a noisy speech signal, comprising

- a first filter having at least two inputs and arranged for outputting a speech reference signal and at least one noise reference signal,
 - a filter to apply the speech reference signal to and
 - 5 filters to apply each of the at least one noise reference signals to, and
 - summation means for subtracting from the speech reference signal the filtered speech reference signal and each of the filtered noise reference signals.
- 10 [0027] Advantageously, the first filter is a spatial pre-processor filter, comprising a beamformer filter and a blocking matrix filter.
- [0028] In an alternative embodiment the beamformer filter is a delay-and-sum beamformer.
- 15 [0029] The invention also relates to a hearing device comprising a signal processing circuit as described. By hearing device is meant an acoustical hearing aid (either external or implantable) or a cochlear implant.
- 20 Short description of the drawings
- [0030] Fig. 1 represents the concept of the Generalised Sidelobe Canceller.
- [0031] Fig. 2 represents an equivalent approach of multi-channel Wiener filtering.
- 25 [0032] Fig. 3 represents a Spatially Pre-processed SDW-MWF.
- [0033] Fig. 4 represents the decomposition of SP-SDW-MWF with w_0 in a multi-channel filter w_d and single-channel postfilter e_1-w_0 .
- 30 [0034] Fig. 5 represents the set-up for the experiments.

[0035] Fig. 6 represents the influence of $1/\mu$ on the performance of the SDR GSC for different gain mismatches Υ_2 at the second microphone.

[0036] Fig. 7 represents the influence of $1/\mu$ on the performance of the SP-SDW-MWF with w_0 for different gain mismatches Υ_2 at the second microphone.

[0037] Fig. 8 represents the $\Delta\text{SNR}_{\text{intellig}}$ and $\text{SD}_{\text{intellig}}$ for QIC-GSC as a function of β^2 for different gain mismatches Υ_2 at the second microphone.

10 [0038] Fig. 9 represents the complexity of TD and FD Stochastic Gradient (SG) algorithm with LP filter as a function of filter length L per channel; $M=3$ (for comparison, the complexity of the standard NLMS ANC and SPA are depicted too).

15 [0039] Fig. 10 represents the performance of different FD Stochastic Gradient (FD-SG) algorithms; (a) Stationary speech-like noise at 90° ; (b) Multi-talker babble noise at 90° .

[0040] Fig. 11 represents the influence of the LP filter on performance of FD stochastic gradient SP-SDW-MWF ($1/\mu=0.5$) without w_0 and with w_0 . Babble noise at 90° .

[0041] Fig. 12 represents the convergence behaviour of FD-SG for $\lambda=0$ and $\lambda=0.9998$. The noise source position suddenly changes from 90° to 180° and vice versa.

25 [0042] Fig. 13 represents the performance of FD stochastic gradient implementation of SP-SDW-MWF with LP filter ($\lambda=0.9998$) in a multiple noise source scenario.

[0043] Fig. 14 represents the performance of FD SPA in a multiple noise source scenario.

30 [0044] Fig. 15 represents the SNR improvement of the frequency-domain SP-SDW-MWF (Algorithm 2 and Algorithm 4) in a multiple noise source scenario.

[0045] Fig. 16 represents the speech distortion of the frequency-domain SP-SDW-MWF (Algorithm 2 and Algorithm 4) in a multiple noise source scenario.

5 Detailed description of the invention

[0046] The present invention is now described in detail. First, the proposed adaptive multi-channel noise reduction technique, referred to as Spatially Pre-processed Speech Distortion Weighted Multi-channel Wiener filter, is
10 described.

[0047] A first aspect of the invention is referred to as *Speech Distortion Regularised GSC* (SDR-GSC). A new design criterion is developed for the adaptive stage of the GSC: the ANC design criterion is supplemented with a
15 regularisation term that limits speech distortion due to signal model errors. In the SDR-GSC, a parameter μ is incorporated that allows for a trade-off between speech distortion and noise reduction. Focussing all attention towards noise reduction, results in the standard GSC,
20 while, on the other hand, focussing all attention towards speech distortion results in the output of the fixed beamformer. In noise scenarios with low SNR, adaptivity in the SDR-GSC can be easily reduced or excluded by increasing attention towards speech distortion, i.e., by decreasing
25 the parameter μ to 0. The SDR-GSC is an alternative to the QIC-GSC to decrease the sensitivity of the GSC to signal model errors such as microphone mismatch, reverberation, ... In contrast to the QIC-GSC, the SDR-GSC shifts emphasis towards speech distortion when the amount of speech leakage
30 grows. In the absence of signal model errors, the performance of the GSC is preserved. As a result, a better noise reduction performance is obtained for small model errors, while guaranteeing robustness against large model errors.

[0048] In a next step, the noise reduction performance of the SDR-GSC is further improved by adding an extra adaptive filtering operation w_0 on the speech reference signal. This generalised scheme is referred to as

5 *Spatially Pre-processed Speech Distortion Weighted Multi-channel Wiener Filter* (SP-SDW-MWF). The SP-SDW-MWF is depicted in Fig. 3 and encompasses the MWF as a special case. Again, a parameter μ is incorporated in the design criterion to allow for a trade-off between speech

10 distortion and noise reduction. Focussing all attention towards speech distortion, results in the output of the fixed beamformer. Also here, adaptivity can be easily reduced or excluded by decreasing μ to 0. It is shown that

-in the absence of speech leakage and for infinitely long

15 filter lengths- the SP-SDW-MWF corresponds to a cascade of a SDR-GSC with a Speech Distortion Weighted Single-channel Wiener filter (SDW-SWF). In the presence of speech leakage, the SP-SDW-MWF with w_0 tries to preserve its performance: the SP-SDW-MWF then contains extra filtering operations

20 that compensate for the performance degradation due to speech leakage. Hence, in contrast to the SDR-GSC (and thus also the GSC), performance does not degrade due to microphone mismatch. Recursive implementations of the (SDW-)MWF exist that are based on a GSVD or QR decomposition.

25 Additionally, a subband implementation results in improved intelligibility at a significantly lower complexity compared to the fullband approach. These techniques can be extended to implement the SDR-GSC and, more generally, the SP-SDW-MWF.

30 [0049] In this invention, cheap *time-domain and frequency-domain stochastic gradient implementations* of the SDR-GSC and the SP-SDW-MWF are proposed as well. Starting from the design criterion of the SDR-GSC, or more generally, the SP-SDW-MWF, a time-domain stochastic

gradient algorithm is derived. To increase the convergence speed and reduce the computational complexity, the algorithm is implemented in the frequency-domain. To reduce the large excess error from which the stochastic gradient
5 algorithm suffers when used in highly non-stationary noise, a low pass filter is applied to the part of the gradient estimate that limits speech distortion. The low pass filter avoids a highly time-varying distortion of the desired speech component while not degrading the tracking
10 performance needed in time-varying noise scenarios. Experimental results show that the low pass filter significantly improves the performance of the stochastic gradient algorithm and does not compromise the tracking of changes in the noise scenario. In addition, experiments
15 demonstrate that the proposed stochastic gradient algorithm preserves the benefit of the SP-SDW-MWF over the QIC-GSC, while its computational complexity is comparable to the NLMS based scaled projection algorithm for implementing the QIC. The stochastic gradient algorithm with low pass filter
20 however requires data buffers, which results in a large memory cost. The memory cost can be decreased by approximating the regularisation term in the frequency-domain using (diagonal) correlation matrices, making an implementation of the SP-SDW-MWF in commercial hearing aids
25 feasible both in terms of complexity as well as memory cost. Experimental results show that the stochastic gradient algorithm using correlation matrices has the same performance as the stochastic gradient algorithm with low pass filter.

30

Spatially pre-processed SDW Multi-channel Wiener Filter

Concept

[0050] Fig. 3 depicts the Spatially pre-processed, Speech Distortion Weighted Multi-channel Wiener filter (SP-SDW-MWF). The SP-SDW-MWF consists of a fixed, spatial pre-processor, i.e. a fixed beamformer $A(z)$ and a blocking matrix $B(z)$, and an adaptive Speech Distortion Weighted Multi-channel Wiener filter (SDW-MWF). Given M microphone signals

$$u_i[k] = u_i^s[k] + u_i^n[k], i = 1, \dots, M \quad (\text{equation 30})$$

10 with $u_i^s[k]$ the desired speech contribution and $u_i^n[k]$ the noise contribution, the fixed beamformer $A(z)$ creates a so-called speech reference

$$y_0[k] = y_0^s[k] + y_0^n[k], \quad (\text{equation 31})$$

by steering a beam towards the direction of the desired
 15 signal, and comprising a speech contribution $y_0^s[k]$ and a noise contribution $y_0^n[k]$. To preserve the robustness advantage of the MWF, the fixed beamformer $A(z)$ should be designed such that the distortion in the speech reference $y_0^s[k]$ is minimal for all possible errors in the assumed
 20 signal model such as microphone mismatch. In the sequel, a delay-and-sum beamformer is used. For small-sized arrays, this beamformer offers sufficient robustness against signal model errors as it minimises the noise sensitivity. Given statistical knowledge about the signal model errors that
 25 occur in practice, a further optimised filter-and-sum beamformer $A(z)$ can be designed. The blocking matrix $B(z)$ creates $M-1$ so-called noise references

$$y_i[k] = y_i^s[k] + y_i^n[k], \quad i = 1, \dots, M-1 \quad (\text{equation 32})$$

by steering zeroes towards the direction of interest such
 30 that the noise contributions $y_i^n[k]$ are dominant compared to the speech leakage contributions $y_i^s[k]$. A simple technique

to create the noise references consists of pairwise subtracting the time-aligned microphone signals. Further optimised noise references can be created, e.g. by minimising speech leakage for a specified angular region
 5 around the direction of interest instead of for the direction of interest only (e.g. for an angular region from -20° to 20° around the direction of interest). In addition, given statistical knowledge about the signal model errors that occur in practice, speech leakage can be minimised for
 10 all possible signal model errors.

[0051] In the sequel, the superscripts s and n are used to refer to the speech and the noise contribution of a signal. During periods of speech + noise, the references $y_i[k]$, $i=0,\dots,M-1$ contain speech + noise. During periods of
 15 noise only, $y_i[k]$, $i=0,\dots,M-1$ only consist of a noise component, i.e. $y_i[k]=y_i^n[k]$. The second order statistics of the noise signal are assumed to be quite stationary such that they can be estimated during periods of noise only.

[0052] The SDW-MWF filter $w_{0:M-1}$

$$20 \quad \mathbf{w}_{0:M-1} = \left(\frac{1}{\mu} E\{\mathbf{y}_{0:M-1}^s[k] \mathbf{y}_{0:M-1}^{s,H}[k]\} + E\{\mathbf{y}_{0:M-1}^n[k] \mathbf{y}_{0:M-1}^{n,H}[k]\} \right)^{-1} E\{\mathbf{y}_{0:M-1}^n[k] \mathbf{y}_0^{n,*}[k-\Delta]\},$$

(equation 33)

with

$$\mathbf{w}_{0:M-1}^H[k] = [\mathbf{w}_0^H[k] \quad \mathbf{w}_1^H[k] \quad \dots \quad \mathbf{w}_{M-1}^H[k]], \quad (\text{equation 34})$$

$$\mathbf{w}_i[k] = [w_i[0] \quad w_i[1] \quad \dots \quad w_i[L-1]]^T \quad (\text{equation 35})$$

$$25 \quad \mathbf{y}_{0:M-1}^H[k] = [\mathbf{y}_0^H[k] \quad \mathbf{y}_1^H[k] \quad \dots \quad \mathbf{y}_{M-1}^H[k]], \quad (\text{equation 36})$$

$$\mathbf{y}_i[k] = [y_i[k] \quad y_i[k-1] \quad \dots \quad y_i[k-L+1]]^T, \quad (\text{equation 37})$$

provides an estimate $\mathbf{w}_{0:M-1}^H \mathbf{y}_{0:M-1}[k]$ of the noise contribution $y_0^n[k-\Delta]$ in the speech reference by minimising the cost function $J(\mathbf{w}_{0:M-1})$

$$J(\mathbf{w}_{0:M-1}) = \frac{1}{\mu} E \left\{ \left\| \mathbf{w}_{0:M-1}^H \mathbf{y}_{0:M-1}^s[k] \right\|^2 \right\}_{\varepsilon_d^2} + E \left\{ \left\| y_0^r[k-\Delta] - \mathbf{w}_{0:M-1}^H \mathbf{y}_{0:M-1}^n[k] \right\|^2 \right\}_{\varepsilon_n^2} \tag{equation 38}$$

The subscript $0:M-1$ in $\mathbf{w}_{0:M-1}$ and $\mathbf{y}_{0:M-1}$ refers to the subscripts of the first and the last channel component of the adaptive filter and the input vector, respectively. The term ε_d^2 represents the speech distortion energy and ε_n^2 the residual noise energy. The term $\frac{1}{\mu} \varepsilon_d^2$ in the cost function (eq.38) limits the possible amount of speech distortion at the output of the SP-SDW-MWF. Hence, the SP-SDW-MWF adds robustness against signal model errors to the GSC by taking speech distortion explicitly into account in the design criterion of the adaptive stage. The parameter $\frac{1}{\mu} \in [0, \infty)$ trades off noise reduction and speech distortion: the larger $1/\mu$, the smaller the amount of possible speech distortion. For $\mu=0$, the output of the fixed beamformer $A(z)$, delayed by Δ samples is obtained. Adaptivity can be easily reduced or excluded in the SP-SDW-MWF by decreasing μ to 0 (e.g., in noise scenarios with very low signal-to-noise Ratio (SNR), e.g., -10 dB, a fixed beamformer may be preferred.) Additionally, adaptivity can be limited by applying a QIC to $\mathbf{w}_{0:M-1}$.

[0053] Note that when the fixed beamformer $A(z)$ and the blocking matrix $B(z)$ are set to

$$\mathbf{A}(z) = [1 \ 0 \ \dots \ 0]^H \tag{equation 39}$$

$$\mathbf{B}(z) = \begin{bmatrix} 0 & 1 & 0 & L & 0 \\ 0 & 0 & 0 & 0 & M \\ M & 0 & 0 & 1 & 0 \\ 0 & L & 0 & 0 & 1 \end{bmatrix}^H, \tag{equation 40}$$

one obtains the original SDW-MWF that operates on the received microphone signals $u_i[k], i=1, \dots, M$.

[0054] Below, the different parameter settings of the SP-SDW-MWF are discussed. Depending on the setting of the parameter μ and the presence or the absence of the filter \mathbf{w}_0 , the GSC, the (SDW-)MWF as well as in-between solutions such as the Speech Distortion Regularised GSC (SDR-GSC) are obtained. One distinguishes between two cases, i.e. the case where no filter \mathbf{w}_0 is applied to the speech reference (filter length $L_0=0$) and the case where an additional filter \mathbf{w}_0 is used ($L_0 \neq 0$).

10

SDR-GSC, i.e., SP-SDW-MWF without \mathbf{w}_0

[0055] First, consider the case *without* \mathbf{w}_0 , i.e. $L_0=0$. The solution for $\mathbf{w}_{1:M-1}$ in (eq.33) then reduces to

$$\arg \min_{\mathbf{w}_{1:M-1}} \frac{1}{\mu} E \left\{ \left\| \mathbf{w}_{1:M-1}^H \mathbf{y}_{1:M-1}^s[k] \right\|_{\varepsilon_d^2}^2 \right\} + E \left\{ \left\| \mathbf{y}_0^n[k-\Delta] - \mathbf{w}_{1:M-1}^H \mathbf{y}_{1:M-1}^n[k] \right\|_{\varepsilon_n^2}^2 \right\}, \quad (\text{equation 41})$$

15 leading to

$$\mathbf{w}_{1:M-1} = \left(\frac{1}{\mu} E \left\{ \mathbf{y}_{1:M-1}^s[k] \mathbf{y}_{1:M-1}^{s,H}[k] \right\} + E \left\{ \mathbf{y}_{1:M-1}^n[k] \mathbf{y}_{1:M-1}^{n,H}[k] \right\} \right)^{-1} E \left\{ \mathbf{y}_{1:M-1}^n[k] \mathbf{y}_0^{n,*}[k-\Delta] \right\} \quad (\text{equation 42})$$

where ε_d^2 is the speech distortion energy and ε_n^2 the residual noise energy.

20 [0056] Compared to the optimisation criterion (eq.6) of the GSC, a regularisation term

$$\frac{1}{\mu} E \left\{ \left\| \mathbf{w}_{1:M-1}^H \mathbf{y}_{1:M-1}^s[k] \right\|^2 \right\} \quad (\text{equation 43})$$

has been added. This regularisation term limits the amount of speech distortion that is caused by the filter $\mathbf{w}_{1:M-1}$ when speech leaks into the noise references, i.e. $y_i^s[k] \neq 0, i=1, \dots, M-1$. In the sequel, the SP-SDW-MWF with $L_0=0$ is therefore referred to as the *Speech Distortion Regularized GSC (SDR-GSC)*. The smaller μ , the smaller the resulting amount of speech distortion will be. For $\mu=0$, all

25

emphasis is put on speech distortion such that $z[k]$ is equal to the output of the fixed beamformer $A(z)$ delayed by Δ samples. For $\mu=\infty$ all emphasis is put on noise reduction and speech distortion is not taken into account. This corresponds to the standard GSC. Hence, the SDR-GSC encompasses the GSC as a special case.

[0057] The regularisation term (eq.43) with $1/\mu \neq 0$ adds robustness to the GSC, while not affecting the noise reduction performance in the absence of speech leakage:

- 10 • In the absence of speech leakage, i.e., $y_i^s[k]=0, i=1,\dots,M-1$, the regularisation term equals 0 for all $w_{1:M-1}$ and hence the residual noise energy ε_n^2 is effectively minimised. In other words, in the absence of speech leakage, the GSC solution is
- 15 obtained.
- In the presence of speech leakage, i.e., $y_i^s[k] \neq 0, i=1,\dots,M-1$, speech distortion is explicitly taken into account in the optimisation criterion (eq.41) for the adaptive filter $w_{1:M-1}$, limiting speech
- 20 distortion while reducing noise. The larger the amount of speech leakage, the more attention is paid to speech distortion.

To limit speech distortion alternatively, a QIC is often imposed on the filter $w_{1:M-1}$. In contrast to the SDR-GSC, the QIC acts irrespective of the amount of speech leakage $y^s[k]$ that is present. The constraint value β^2 in (eq.11) has to be chosen based on the largest model errors that may occur. As a consequence, noise reduction performance is compromised even when no or very small model errors are present. Hence, the QIC is more conservative than the SDR-GSC, as will be shown in the experimental results.

SP-SDW-MWF with filter w_0

[0058] Since the SDW-MWF (eq.33) takes speech distortion explicitly into account in its optimisation criterion, an additional filter w_0 on the speech reference
 5 $y_0[k]$ may be added. The SDW-MWF (eq.33) then solves the following more general optimisation criterion

$$w_{0:M-1} = \arg \min_{w_{0:M-1}} E \left\{ \left[y_0^n[k-\Delta] - \begin{bmatrix} w_0^H & w_{1:M-1}^H \end{bmatrix} \begin{bmatrix} y_0^n[k] \\ y_{1:M-1}^n[k] \end{bmatrix} \right]^2 \right\}_{\varepsilon_n^2} + \frac{1}{\mu} E \left\{ \left[\begin{bmatrix} w_0^H & w_{1:M-1}^H \end{bmatrix} \begin{bmatrix} y_0^s[k] \\ y_{1:M-1}^s[k] \end{bmatrix} \right]^2 \right\}_{\varepsilon_d^2}$$

(equation 44)

where $w_{0:M-1}^H = [w_0^H \ w_{1:M-1}^H]$ is given by (eq.33).

10 [0059] Again, μ trades off speech distortion and noise reduction. For $\mu=\infty$ speech distortion ε_d^2 is completely ignored, which results in a zero output signal. For $\mu=0$ all emphasis is put on speech distortion such that the output signal is equal to the output of the fixed beamformer
 15 delayed by Δ samples.

In addition, the observation can be made that in the absence of speech leakage, i.e., $y_i^s[k]=0, i=1,\dots,M-1$, and for infinitely long filters $w_i, i=0,\dots,M-1$, the SP-SDW-MWF (with w_0) corresponds to a cascade of an SDR-GSC and an SDW
 20 single-channel WF (SDW-SWF) postfilter. In the presence of speech leakage, the SP-SDW-MWF (with w_0) tries to preserve its performance: the SP-SDW-MWF then contains extra filtering operations that compensate for the performance degradation due to speech leakage. This is illustrated in
 25 Fig. 4. It can e.g. be proven that, for infinite filter lengths, the performance of the SP-SDW-MWF (with w_0) is not affected by microphone mismatch as long as the desired

speech component at the output of the fixed beamformer $\mathbf{A}(z)$ remains unaltered.

Experimental results

5 [0060] The theoretical results are now illustrated by means of experimental results for a hearing aid application. First, the set-up and the performance measures used, are described. Next, the impact of the different parameter settings of the SP-SDW-MWF on the performance and
10 the sensitivity to signal model errors is evaluated. Comparison is made with the QIC-GSC.

[0061] Fig. 5 depicts the set-up for the experiments. A three-microphone Behind-The-Ear (BTE) hearing aid with three omnidirectional microphones (Knowles
15 FG-3452) has been mounted on a dummy head in an office room. The interspacing between the first and the second microphone is about 1 cm and the interspacing between the second and the third microphone is about 1.5 cm. The reverberation time T_{60dB} of the room is about 700 ms for a
20 speech weighted noise. The desired speech signal and the noise signals are uncorrelated. Both the speech and the noise signal have a level of 70 dB SPL at the centre of the head. The desired speech source and noise sources are positioned at a distance of 1 meter from the head: the
25 speech source in front of the head (0°), the noise sources at an angle θ w.r.t. the speech source (see also Fig. 5). To get an idea of the average performance based on directivity only, stationary speech and noise signals with the same, average long-term power spectral density are
30 used. The total duration of the input signal is 10 seconds of which 5 seconds contain noise only and 5 seconds contain both the speech and the noise signal. For evaluation purposes, the speech and the noise signal have been recorded separately.

[0062] The microphone signals are pre-whitened prior to processing to improve intelligibility, and the output is accordingly de-whitened. In the experiments, the microphones have been calibrated by means of recordings of an anechoic speech weighted noise signal positioned at 0°, measured while the microphone array is mounted on the head. A delay-and-sum beamformer is used as a fixed beamformer, since -in case of small microphone interspacing - it is known to be very robust to model errors. The blocking matrix **B** pairwise subtracts the time aligned calibrated microphone signals.

[0063] To investigate the effect of the different parameter settings (i.e. μ , \mathbf{w}_0) on the performance, the filter coefficients are computed using (eq.33) where $E\{\mathbf{y}_{0:M-1}^s \mathbf{y}_{0:M-1}^{s,H}\}$ is estimated by means of the clean speech contributions of the microphone signals. In practice, $E\{\mathbf{y}_{0:M-1}^s \mathbf{y}_{0:M-1}^{s,H}\}$ is approximated using (eq.27). The effect of the approximation (eq.27) on the performance was found to be small (i.e. differences of at most 0.5 dB in intelligibility weighted SNR improvement) for the given data set. The QIC-GSC is implemented using variable loading RLS. The filter length L per channel equals 96.

[0064] To assess the performance of the different approaches, the broadband intelligibility weighted SNR improvement is used, defined as

$$\Delta \text{SNR}_{\text{intellig}} = \sum_i I_i (\text{SNR}_{i,\text{out}} - \text{SNR}_{i,\text{in}}), \quad (\text{equation 45})$$

where the band importance function I_i expresses the importance of the i -th one-third octave band with centre frequency f_i^c for intelligibility, $\text{SNR}_{i,\text{out}}$ is the output SNR (in dB) and $\text{SNR}_{i,\text{in}}$ is the input SNR (in dB) in the i -th one third octave band (*ANSI S3.5-1997, American National Standard Methods for Calculation of the Speech*

Intelligibility Index'). The intelligibility weighted SNR reflects how much intelligibility is improved by the noise reduction algorithm, but does not take into account speech distortion.

- 5 [0065] To measure the amount of speech distortion, we define the following intelligibility weighted spectral distortion measure

$$SD_{\text{intellig}} = \sum_i I_i SD_i \quad (\text{equation 46})$$

- with SD_i the average spectral distortion (dB) in i -th one-
10 third band, measured as

$$SD_i = \int_{2^{-1/6} f_i^c}^{2^{1/6} f_i^c} |10 \log_{10} G^s(f)| df / [(2^{1/6} - 2^{-1/6}) f_i^c], \quad (\text{equation 47})$$

- with $G^s(f)$ the power transfer function of speech from the input to the output of the noise reduction algorithm. To exclude the effect of the spatial pre-processor, the
15 performance measures are calculated w.r.t. the output of the fixed beamformer.

- [0066] The impact of the different parameter settings for μ and w_0 on the performance of the SP-SDW-MWF is illustrated for a five noise source scenario. The five
20 noise sources are positioned at angles 75° , 120° , 180° , 240° , 285° w.r.t. the desired source at 0° . To assess the sensitivity of the algorithm against errors in the assumed signal model, the influence of microphone mismatch, e.g., gain mismatch of the second microphone, on the performance
25 is evaluated. Among the different possible signal model errors, microphone mismatch was found to be especially harmful to the performance of the GSC in a hearing aid application. In hearing aids, microphones are rarely matched in gain and phase. Gain and phase differences
30 between microphone characteristics of up to 6 dB and 10° , respectively, have been reported.

SP-SDW-MWF without w_0 (SDR-GSC)

[0067] Fig. 6 plots the improvement $\Delta SNR_{intellig}$ and the speech distortion $SD_{intellig}$ as a function of $1/\mu$ obtained by the SDR-GSC (i.e., the SP-SDW-MWF without
5 filter w_0) for different gain mismatches γ_2 at the second microphone. In the absence of microphone mismatch, the amount of speech leakage into the noise references is limited. Hence, the amount of speech distortion is low for all μ . Since there is still a small amount of speech
10 leakage due to reverberation, the amount of noise reduction and speech distortion slightly decreases for increasing $1/\mu$, especially for $1/\mu > 1$. In the presence of microphone mismatch, the amount of speech leakage into the noise references grows. For $1/\mu=0$ (GSC), the speech gets
15 significantly distorted. Due to the cancellation of the desired signal, also the improvement $\Delta SNR_{intellig}$ degrades. Setting $1/\mu > 0$ improves the performance of the GSC in the presence of model errors without compromising performance in the absence of signal model errors. For the given set-
20 up, a value $1/\mu$ around 0.5 seems appropriate for guaranteeing good performance for a gain mismatch up to 4dB.

SP-SDW-MWF with filter w_0

25 [0068] Fig. 7 plots the performance measures $\Delta SNR_{intellig}$ and $SD_{intellig}$ of the SP-SDW-MWF with filter w_0 . In general, the amount of speech distortion and noise reduction grows for decreasing $1/\mu$. For $1/\mu=0$, all emphasis is put on noise reduction. As also illustrated by Fig. 7,
30 this results in a total cancellation of the speech and the noise signal and hence degraded performance. In the absence of model errors, the settings $L_0=0$ and $L_0 \neq 0$ result - except for $1/\mu=0$ - in the same $\Delta SNR_{intellig}$, while the distortion

for the SP-SDW-MWF with w_0 is higher due to the additional single-channel SDW-SWF. For $L_0 \neq 0$ the performance does -in contrast to $L_0=0$ - not degrade due to the microphone mismatch.

5 [0069] Fig. 8 depicts the improvement $\Delta \text{SNR}_{\text{intellig}}$ and the speech distortion $\text{SD}_{\text{intellig}}$, respectively, of the QIC-GSC as a function of β^2 . Like the SDR-GSC, the QIC increases the robustness of the GSC. The QIC is independent of the amount of speech leakage. As a consequence,
10 distortion grows fast with increasing gain mismatch. The constraint value β should be chosen such that the maximum allowable speech distortion level is not exceeded for the largest possible model errors. Obviously, this goes at the expense of reduced noise reduction for small model errors.
15 The SDR-GSC on the other hand, keeps the speech distortion limited for all model errors (see Fig. 6). Emphasis on speech distortion is increased if the amount of speech leakage grows. As a result, a better noise reduction performance is obtained for small model errors, while
20 guaranteeing sufficient robustness for large model errors. In addition, Fig. 7 demonstrates that an additional filter w_0 significantly improves the performance in the presence of signal model errors.

[0070] In the previously discussed embodiments a
25 generalised noise reduction scheme has been established, referred to as *Spatially pre-processed, Speech Distortion Weighted Multi-channel Wiener Filter (SP-SDW-MWF)*, that comprises a fixed, spatial pre-processor and an adaptive stage that is based on a SDW-MWF. The new scheme
30 encompasses the GSC and MWF as special cases. In addition, it allows for an in-between solution that can be interpreted as a Speech Distortion Regularised GSC (SDR-GSC). Depending on the setting of a trade-off parameter μ

and the presence or absence of the filter w_0 on the speech reference, the GSC, the SDR-GSC or a (SDW-)MWF is obtained. The different parameter settings of the SP-SDW-MWF can be interpreted as follows:

- 5 • Without w_0 , the SP-SDW-MWF corresponds to an SDR-GSC: the ANC design criterion is supplemented with a regularisation term that limits the speech distortion due to signal model errors. The larger $1/\mu$, the smaller the amount of distortion. For $1/\mu=0$,
- 10 distortion is completely ignored, which corresponds to the GSC-solution. The SDR-GSC is then an alternative technique to the QIC-GSC to decrease the sensitivity of the GSC to signal model errors. In contrast to the QIC-GSC, the SDR-GSC shifts emphasis towards speech
- 15 distortion when the amount of speech leakage grows. In the absence of signal model errors, the performance of the GSC is preserved. As a result, a better noise reduction performance is obtained for small model errors, while guaranteeing robustness against large
- 20 model errors.
- * Since the SP-SDW-MWF takes speech distortion explicitly into account, a filter w_0 on the speech reference can be added. It can be shown that -in the absence of speech leakage and for infinitely long
- 25 filter lengths- the SP-SDW-MWF corresponds to a cascade of an SDR-GSC with an SDW-SWF postfilter. In the presence of speech leakage, the SP-SDW-MWF with w_0 tries to preserve its performance: the SP-SDW-MWF then contains extra filtering operations that compensate
- 30 for the performance degradation due to speech leakage. In contrast to the SDR-GSC (and thus also the GSC), the performance does not degrade due to microphone mismatch.

Experimental results for a hearing aid application confirm the theoretical results. The SP-SDW-MWF indeed increases the robustness of the GSC against signal model errors. A comparison with the widely studied QIC-GSC demonstrates
5 that the SP-SDW-MWF achieves a better noise reduction performance for a given maximum allowable speech distortion level.

Stochastic gradient implementations

10 [0071] Recursive implementations of the (SDW-)MWF have been proposed based on a GSVD or QR decomposition. Additionally, a subband implementation results in improved intelligibility at a significantly lower cost compared to the fullband approach. These techniques can be extended to
15 implement the SP-SDW-MWF. However, in contrast to the GSC and the QIC-GSC, no cheap stochastic gradient based implementation of the SP-SDW-MWF is available. In the present invention, time-domain and frequency-domain stochastic gradient implementations of the SP-SDW-MWF are
20 proposed that preserve the benefit of matrix-based SP-SDW-MWF over QIC-GSC. Experimental results demonstrate that the proposed stochastic gradient implementations of the SP-SDW-MWF outperform the SPA, while their computational cost is limited.

25 [0072] Starting from the cost function of the SP-SDW-MWF, a time-domain stochastic gradient algorithm is derived. To increase the convergence speed and reduce the computational complexity, the stochastic gradient algorithm is implemented in the frequency-domain. Since the
30 stochastic gradient algorithm suffers from a large excess error when applied in highly time-varying noise scenarios, the performance is improved by applying a low pass filter to the part of the gradient estimate that limits speech distortion. The low pass filter avoids a highly time-

varying distortion of the desired speech component while not degrading the tracking performance needed in time-varying noise scenarios. Next, the performance of the different frequency-domain stochastic gradient algorithms is compared. Experimental results show that the proposed stochastic gradient algorithm preserves the benefit of the SP-SDW-MWF over the QIC-GSC. Finally, it is shown that the memory cost of the frequency-domain stochastic gradient algorithm with low pass filter is reduced by approximating the regularisation term in the frequency-domain using (diagonal) correlation matrices instead of data buffers. Experiments show that the stochastic gradient algorithm using correlation matrices has the same performance as the stochastic gradient algorithm with low pass filter.

15

Stochastic gradient algorithm

Derivation

[0073] A stochastic gradient algorithm approximates the steepest descent algorithm, using an instantaneous gradient estimate. Given the cost function (eq.38), the steepest descent algorithm iterates as follows (note that in the sequel the subscripts $0:M-1$ in the adaptive filter $\mathbf{w}_{0:M-1}$ and the input vector $\mathbf{y}_{0:M-1}$ are omitted for the sake of conciseness):

$$\begin{aligned} \mathbf{w}[n+1] &= \mathbf{w}[n] + \frac{\rho}{2} \left(-\frac{\partial J(\mathbf{w})}{\partial \mathbf{w}} \right)_{\mathbf{w}=\mathbf{w}[n]} \\ &= \mathbf{w}[n] + \rho \left(E\{\mathbf{y}^n[k] \mathbf{y}_0^{n,*}[k-\Delta]\} - E\{\mathbf{y}^n[k] \mathbf{y}^{n,H}[k]\} \mathbf{w}[n] - \frac{1}{\mu} E\{\mathbf{y}^s[k] \mathbf{y}^{s,H}[k]\} \mathbf{w}[n] \right), \end{aligned}$$

(equation 48)

with $\mathbf{w}[k], \mathbf{y}[k] \in C^{NL \times 1}$, where N denotes the number of input channels to the adaptive filter and L the number of filter taps per channel. Replacing the iteration index n by a time

30

index k and leaving out the expectation values $E\{.\}$, one obtains the following update equation

$$\mathbf{w}[k+1] = \mathbf{w}[k] + \rho \left\{ \mathbf{y}^n[k](y_0^{n,*}[k-\Delta] - \mathbf{y}^{n,H}[k]\mathbf{w}[k]) - \frac{1}{\mu} \mathbf{y}^s[k] \mathbf{y}^{s,H}[k] \mathbf{w}[k] \right\} + \mathbf{r}[k] \quad \text{(equation 49)}$$

5 For $1/\mu=0$ and no filter \mathbf{w}_0 on the speech reference, (eq.49) reduces to the update formula used in GSC during periods of noise only (i.e., when $y_i[k]=y_i^n[k], i=0,\dots,M-1$). The additional term $\mathbf{r}[k]$ in the gradient estimate limits the speech distortion due to possible signal model errors.

10 [0074] Equation (49) requires knowledge of the correlation matrix $\mathbf{y}^s[k] \mathbf{y}^{s,H}[k]$ or $E\{\mathbf{y}^s[k] \mathbf{y}^{s,H}[k]\}$ of the clean speech. In practice, this information is not available. To avoid the need for calibration, *speech + noise* signal vectors \mathbf{y}_{buf_i} are stored into a circular buffer $\mathbf{B}_i \in R^{N \times L_{buf_i}}$ during processing. During periods of noise only (i.e., when $y_i[k]=y_i^n[k], i=0,\dots,M-1$), the filter \mathbf{w} is updated using the following approximation of the term $\mathbf{r}[k]=\frac{1}{\mu} \mathbf{y}^s[k] \mathbf{y}^{s,H}[k] \mathbf{w}[k]$ in (eq.49)

$$\frac{1}{\mu} \mathbf{y}^s \mathbf{y}^{s,H}[k] \mathbf{w}[k] \approx \frac{1}{\mu} (\mathbf{y}_{buf_i} \mathbf{y}_{buf_i}^H[k] - \mathbf{y} \mathbf{y}^H[k]) \mathbf{w}[k], \quad \text{(equation 50)}$$

20 which results in the update formula

$$\mathbf{w}[k+1] = \mathbf{w}[k] + \rho \left\{ \mathbf{y}[k](y_0^*[k-\Delta] - \mathbf{y}^H[k]\mathbf{w}[k]) - \frac{1}{\mu} (\mathbf{y}_{buf_i} \mathbf{y}_{buf_i}^H[k] - \mathbf{y}[k] \mathbf{y}^H[k]) \mathbf{w}[k] \right\} + \mathbf{r}[k] \quad \text{(equation 51)}$$

In the sequel, a normalised step size ρ is used, i.e.

$$\rho = \frac{\rho'}{\frac{1}{\mu} |\mathbf{y}_{buf_i}^H[k] \mathbf{y}_{buf_i}[k] - \mathbf{y}^H[k] \mathbf{y}[k]| + \mathbf{y}^H[k] \mathbf{y}[k] + \delta}, \quad \text{(equation 52)}$$

where δ is a small positive constant. The absolute value $|\mathbf{y}_{buf_1}^H \mathbf{y}_{buf_1} - \mathbf{y}^H \mathbf{y}|$ has been inserted to guarantee a positive valued estimate of the clean speech energy $\mathbf{y}^{s,H}[k] \mathbf{y}^s[k]$. Additional storage of noise only vectors \mathbf{y}_{buf_2} in a second

5 buffer $\mathbf{B}_2 \in R^{M \times L_{buf_2}}$ allows to adapt \mathbf{w} also during periods of speech + noise, using

$$\mathbf{w}[k+1] = \mathbf{w}[k] + \rho \left\{ \mathbf{y}_{buf_2}[k] (\mathbf{y}_{0,buf_2}^*[k-\Delta] - \mathbf{y}_{buf_2}^H[k] \mathbf{w}[k]) + \frac{1}{\mu} (\mathbf{y}_{buf_2}[k] \mathbf{y}_{buf_2}^H[k] - \mathbf{y}[k] \mathbf{y}^H[k]) \mathbf{w}[k] \right\}$$

(equation 53)

10 with

$$\rho = \frac{\rho'}{\frac{1}{\mu} |\mathbf{y}^H[k] \mathbf{y}[k] - \mathbf{y}_{buf_2}^H[k] \mathbf{y}_{buf_2}[k]| + \mathbf{y}_{buf_2}^H[k] \mathbf{y}_{buf_2}[k] + \delta}. \quad \text{(equation 54)}$$

For reasons of conciseness only the update procedure of the time-domain stochastic gradient algorithms during noise only will be considered in the sequel, hence $\mathbf{y}[k] = \mathbf{y}^n[k]$.

15 The extension towards updating during speech + noise periods with the use of a second, noise only buffer \mathbf{B}_2 is straightforward: the equations are found by replacing the noise-only input vector $\mathbf{y}[k]$ by $\mathbf{y}_{buf_2}[k]$ and the speech + noise vector $\mathbf{y}_{buf_1}[k]$ by the input speech + noise vector

20 $\mathbf{y}[k]$.

It can be shown that the algorithm (eq.51) - (eq.52) is convergent in the mean provided that the step size ρ is smaller than $2/\lambda_{max}$ with λ_{max} the maximum eigenvalue of $E\{\frac{1}{\mu} \mathbf{y}_{buf_1} \mathbf{y}_{buf_1}^H + (1-\frac{1}{\mu}) \mathbf{y} \mathbf{y}^H\}$. The similarity of (eq.51) with standard

25 NLMS let us presume that setting $\rho < \frac{2}{\sum_i^{NL} \lambda_i}$, with λ_i , $i=1, \dots, NL$ the eigenvalues of $E\{\frac{1}{\mu} \mathbf{y}_{buf_1} \mathbf{y}_{buf_1}^H + (1-\frac{1}{\mu}) \mathbf{y} \mathbf{y}^H\} \in R^{NL \times NL}$, or -in case of FIR filters- setting

$$\rho < \frac{2}{\frac{1}{\mu}L \sum_{i=M-N}^{M-1} E\{y_{i,bu_f_1}^2[k]\} + (1-\frac{1}{\mu})L \sum_{i=M-N}^{M-1} E\{y_i^2[k]\}} \quad (\text{equation 55})$$

guarantees convergence in the mean square. Equation (55) explains the normalisation (eq.52) and (eq.54) for the step size ρ .

5 [0075] However, since generally

$$\mathbf{y}[k]\mathbf{y}^H[k] \neq \mathbf{y}_{bu_f_1}^n[k]\mathbf{y}_{bu_f_1}^{n,H}[k], \quad (\text{equation 56})$$

the instantaneous gradient estimate in (eq.51) is -compared to (eq.49)- additionally perturbed by

$$\frac{1}{\mu} \left(\mathbf{y}[k]\mathbf{y}^H[k] - \mathbf{y}_{bu_f_1}^n[k]\mathbf{y}_{bu_f_1}^{n,H}[k] \right) \mathbf{w}[k], \quad (\text{equation 57})$$

10 for $1/\mu \neq 0$. Hence, for $1/\mu \neq 0$, the update equations (eq.51)- (eq.54) suffer from a larger residual excess error than (eq.49). This additional excess error grows for decreasing μ , increasing step size ρ and increasing vector length LN of the vector \mathbf{y} . It is expected to be especially large for
 15 highly non-stationary noise, e.g. multi-talker babble noise.

Remark that for $\mu > 1$, an alternative stochastic gradient algorithm can be derived from algorithm (eq.51)-(eq.54) by invoking some independence assumptions. Simulations,
 20 however, showed that these independence assumptions result in a significant performance degradation, while hardly reducing the computational complexity.

Frequency-domain implementation

25 [0076] As stated before, the stochastic gradient algorithm (eq.51)-(eq.54) is expected to suffer from a large excess error for large ρ'/μ and/or highly time-varying noise, due to a large difference between the rank-one noise correlation matrices $\mathbf{y}^n[k]\mathbf{y}^{n,H}[k]$ measured at
 30 different time instants k . The gradient estimate can be improved by replacing

$$\mathbf{y}_{buf_1}[k]\mathbf{y}_{buf_1}^H[k]-\mathbf{y}[k]\mathbf{y}^H[k] \quad (\text{equation 58})$$

in (eq.51) with the time-average

$$\frac{1}{K} \sum_{l=k-K+1}^k \mathbf{y}_{buf_1}[l]\mathbf{y}_{buf_1}^H[l]-\frac{1}{K} \sum_{l=k-K+1}^k \mathbf{y}[l]\mathbf{y}^H[l], \quad (\text{equation 59})$$

where $\frac{1}{K} \sum_{l=k-K+1}^k \mathbf{y}_{buf_1}[l]\mathbf{y}_{buf_1}^H[l]$ is updated during periods of speech
 5 + noise and $\frac{1}{K} \sum_{l=k-K+1}^k \mathbf{y}[l]\mathbf{y}^H[l]$ during periods of noise only.
 However, this would require expensive matrix operations. A
 block-based implementation intrinsically performs this
 averaging:

$$\begin{aligned} \mathbf{w}[(k+1)K] = & \mathbf{w}[kK] + \frac{\rho}{K} \left[\sum_{i=0}^{K-1} \mathbf{y}[kK+i] \left(\mathbf{y}_0^*[kK+i-\Delta] - \mathbf{y}^H[kK+i] \mathbf{w}[kK] \right) \right. \\ & \left. - \frac{1}{\mu} \sum_{i=0}^{K-1} \left(\mathbf{y}_{buf_1}[kK+i] \mathbf{y}_{buf_1}^H[kK+i] - \mathbf{y}[kK+i] \mathbf{y}^H[kK+i] \right) \mathbf{w}[kK] \right]. \end{aligned}$$

10 (equation 60)

The gradient and hence also $\mathbf{y}_{buf_1}[k]\mathbf{y}_{buf_1}^H[k]-\mathbf{y}[k]\mathbf{y}^H[k]$ is averaged
 over K iterations prior to making adjustments to \mathbf{w} . This
 goes at the expense of a reduced (i.e. by a factor K)
 convergence rate.

15 [0077] The block-based implementation is
 computationally more efficient when it is implemented in
 the frequency-domain, especially for large filter lengths :
 the linear convolutions and correlations can then be
 efficiently realised by FFT algorithms based on overlap-
 20 save or overlap-add. In addition, in a frequency-domain
 implementation, each frequency bin gets its own step size,
 resulting in faster convergence compared to a time-domain
 implementation while not degrading the steady-state excess
 MSE.

25 [0078] Algorithm 1 summarises a frequency-domain
 implementation based on overlap-save of (eq.51)-(eq.54).
 Algorithm 1 requires $(3N+4)$ FFTs of length $2L$. By storing
 the FFT-transformed speech + noise and noise only vectors

in the buffers $\mathbf{B}_1 \in \mathbb{C}^{N \times L_{buf1}}$ and $\mathbf{B}_2 \in \mathbb{C}^{N \times L_{buf2}}$, respectively, instead of storing the time-domain vectors, N FFT operations can be saved. Note that since the input signals are real, half of the FFT components are complex-
 5 conjugated. Hence, in practice only half of the complex FFT components have to be stored in memory. When adapting during speech + noise, also the time-domain vector

$$[y_0[kL-\Delta] \quad L \quad y_0[kL-\Delta+L-1]]^T \quad (\text{equation 61})$$

should be stored in an additional buffer $\mathbf{B}_{2,0} \in \mathbb{R}^{1 \times \frac{L_{buf2}}{2}}$ during
 10 periods of noise-only, which -for $N=M$ - results in an additional storage of $\frac{L_{buf2}}{2}$ words compared to when the time-domain vectors are stored into the buffers \mathbf{B}_1 and \mathbf{B}_2 .

Remark that in Algorithm 1 a common trade-off parameter μ is used in all frequency bins. Alternatively, a different
 15 setting for μ can be used in different frequency bins. E.g. for SP-SDW-MWF with $w_0=0$, $1/\mu$ could be set to 0 at those frequencies where the GSC is sufficiently robust, e.g., for small-sized arrays at high frequencies. In that case, only a few frequency components of the regularisation terms
 20 $\mathbf{R}_i[k]$, $i=M-N, \dots, M-1$, need to be computed, reducing the computational complexity.

Algorithm 1: Frequency-domain stochastic gradient SP-SDW-MWF based on overlap-save

Initialisation:

$$\mathbf{W}_i[0] = [0 \quad L \quad 0]^T, \quad i = M - N, \dots, M - 1$$

$$5 \quad P_m[0] = \delta_m, \quad m = 0, \dots, 2L - 1$$

Matrix definitions:

$$\mathbf{g} = \begin{bmatrix} \mathbf{I}_L & \mathbf{0}_L \\ \mathbf{0}_L & \mathbf{0}_L \end{bmatrix}; \mathbf{k} = [\mathbf{0}_L \quad \mathbf{I}_L]; \mathbf{F} = 2L \times 2L \text{ DFT matrix};$$

For each new block of NL input samples:

◆ *If noise detected:*

$$10 \quad 1. \mathbf{F}[y_i[kL - L] \quad \dots \quad y_i[kL + L - 1]]^T, \quad i = M - N, \dots, M - 1 \rightarrow \text{noise buffer } \mathbf{B}_2$$

$$[y_0[kL - \Delta] \quad \dots \quad y_0[kL - \Delta + L - 1]]^T \rightarrow \text{noise buffer } \mathbf{B}_{2,0}$$

$$2. \mathbf{Y}_i^n[k] = \text{diag}\{\mathbf{F}[y_i[kL - L] \quad \dots \quad y_i[kL + L - 1]]^T\}, \quad i = M - N, \dots, M - 1$$

$$\mathbf{d}[k] = [y_0[kL - \Delta] \quad L \quad y_0[kL - \Delta + L - 1]]^T$$

Create $\mathbf{Y}_i[k]$ from data in speech + noise buffer \mathbf{B}_1 .

15 ◆ *If speech detected:*

$$1. \mathbf{F}[y_i[kL - L] \quad \dots \quad y_i[kL + L - 1]]^T, \quad i = M - N, \dots, M - 1 \rightarrow \text{speech + noise buffer } \mathbf{B}_1$$

$$2. \mathbf{Y}_i[k] = \text{diag}\{\mathbf{F}[y_i[kL - L] \quad \dots \quad y_i[kL + L - 1]]^T\}, \quad i = M - N, \dots, M - 1$$

Create $\mathbf{d}[k]$ and $\mathbf{Y}_i^n[k]$ from noise buffer $\mathbf{B}_{2,0}$ and \mathbf{B}_2

◆ *Update formula:*

$$20 \quad 1. \mathbf{e}_1[k] = \mathbf{kF}^{-1} \sum_{j=M-N}^{M-1} \mathbf{Y}_j^n[k] \mathbf{W}_j[k] = \mathbf{y}_{\text{out},1}$$

$$\mathbf{e}[k] = \mathbf{d}[k] - \mathbf{e}_1[k]$$

$$\mathbf{e}_2[k] = \mathbf{kF}^{-1} \sum_{j=M-N}^{M-1} \mathbf{Y}_j[k] \mathbf{W}_j[k] = \mathbf{y}_{\text{out},2}$$

$$\mathbf{E}_1[k] = \mathbf{Fk}^T \mathbf{e}_1[k]; \mathbf{E}_2[k] = \mathbf{Fk}^T \mathbf{e}_2[k]; \mathbf{E}[k] = \mathbf{Fk}^T \mathbf{e}[k]$$

$$2. \Lambda[k] = \frac{2\mu'}{L} \text{diag}\{P_0^{-1}[k], \dots, P_{2L-1}^{-1}[k]\}$$

$$25 \quad P_m[k] = \gamma P_m[k-1] + (1-\gamma) \left(\sum_{j=M-N}^{M-1} |\mathbf{Y}_{j,m}^n|^2 + \frac{1}{\mu} \left| \sum_{j=M-N}^{M-1} \left(|\mathbf{Y}_{j,m}|^2 - |\mathbf{Y}_{j,m}^n|^2 \right) \right| \right)$$

$$3. \mathbf{W}_i[k+1] = \mathbf{W}_i[k] + \mathbf{FgF}^{-1} \Lambda[k] \left\{ \mathbf{Y}_i^{n,H}[k] \mathbf{E}[k] - \frac{1}{\mu} \left(\mathbf{Y}_i^H \mathbf{E}_2[k] - \mathbf{Y}_i^{n,H} \mathbf{E}_1[k] \right) \right\},$$

$$(i=M-N, \dots, M-1)$$

◆ Output: $\mathbf{y}_0[k] = [y_0[kL-\Delta] \quad \dots \quad y_0[kL-\Delta+L-1]]^T$

- If noise detected: $\mathbf{y}_{\text{out}}[k] = \mathbf{y}_0[k] - \mathbf{y}_{\text{out},1}[k]$
- If speech detected: $\mathbf{y}_{\text{out}}[k] = \mathbf{y}_0[k] - \mathbf{y}_{\text{out},2}[k]$

5

Improvement 1: stochastic gradient algorithm with low pass filter

[0079] For spectrally stationary noise, the limited
 10 (i.e. $K=L$) averaging of (eq.59) by the block-based and
 frequency-domain stochastic gradient implementation may
 offer a reasonable estimate of the short-term speech
 correlation matrix $E\{\mathbf{y}^s \mathbf{y}^{s,H}\}$. However, in practical
 scenarios, the speech and the noise signals are often
 15 spectrally highly non-stationary (e.g. multi-talker babble
 noise) while their long-term spectral and spatial
 characteristics (e.g. the positions of the sources) usually
 vary more slowly in time. For these scenarios, a reliable
 estimate of the long-term speech correlation matrix
 20 $E\{\mathbf{y}^s \mathbf{y}^{s,H}\}$ that captures the spatial rather than the short-
 term spectral characteristics can still be obtained by
 averaging (eq.59) over $K \gg L$ samples. Spectrally highly non-
 stationary noise can then still be spatially suppressed by
 using an estimate of the long-term speech correlation
 25 matrix in the regularisation term $\mathbf{r}[k]$. A cheap method to
 incorporate a long-term averaging ($K \gg L$) of (eq.59) in the
 stochastic gradient algorithm is now proposed, by low pass
 filtering the part of the gradient estimate that takes
 speech distortion into account (i.e. the term $\mathbf{r}[k]$ in
 30 (eq.51)). The averaging method is first explained for the
 time-domain algorithm (eq.51)-(eq.54) and then translated
 to the frequency-domain implementation.

Assume that the long-term spectral and spatial characteristics of the noise are quasi-stationary during at least K speech + noise samples and K noise samples. A reliable estimate of the long-term speech correlation matrix $E\{\mathbf{y}^s \mathbf{y}^{s,H}\}$ is then obtained by (eq.59) with $K \gg L$. To avoid expensive matrix computations, $\mathbf{r}[k]$ can be approximated by

$$\frac{1}{K} \sum_{l=k-K+1}^{l=k} (\mathbf{y}_{buf_1}[l] \mathbf{y}_{buf_1}^H[l] - \mathbf{y}[l] \mathbf{y}^H[l]) \mathbf{w}[l]. \text{ (equation 62)}$$

Since the filter coefficients \mathbf{w} of a stochastic gradient algorithm vary slowly in time, (eq.62) appears a good approximation of $\mathbf{r}[k]$, especially for small step size ρ' . The averaging operation (eq.62) is performed by applying a low pass filter to $\mathbf{r}[k]$ in (eq.51):

$$\mathbf{r}[k] = \lambda \mathbf{r}[k-1] + (1-\lambda) \frac{1}{\mu} (\mathbf{y}_{buf_1}[k] \mathbf{y}_{buf_1}^H[k] - \mathbf{y}[k] \mathbf{y}^H[k]) \mathbf{w}[k], \text{ (equation 63)}$$

where $\lambda < 1$. This corresponds to an averaging window K of about $\frac{1}{1-\lambda}$ samples. The normalised step size ρ is modified into

$$\rho = \frac{\rho'}{r_{avg}[k] + \mathbf{y}^H[k] \mathbf{y}[k] + \delta} \text{ (equation 64)}$$

$$r_{avg}[k] = \lambda r_{avg}[k-1] + (1-\lambda) \frac{1}{\mu} |\mathbf{y}_{buf_1}^H[k] \mathbf{y}_{buf_1}[k] - \mathbf{y}^H[k] \mathbf{y}[k]|. \text{ (equation 65)}$$

Compared to (eq.51), (eq.63) requires $3NL-1$ additional MAC and extra storage of the $NL \times 1$ vector $\mathbf{r}[k]$.

[0080] Equation (63) can be easily extended to the frequency-domain. The update equation for $\mathbf{W}_i[k+1]$ in Algorithm 1 then becomes (Algorithm 2):

$$\mathbf{W}_i[k+1] = \mathbf{W}_i[k] + \mathbf{F} \mathbf{g} \mathbf{F}^{-1} \Delta[k] (\mathbf{Y}_i^{n,H}[k] \mathbf{E}[k] - \mathbf{R}_i[k]);$$

25

$$\mathbf{R}_i[k] = \lambda \mathbf{R}_i[k-1] + (1-\lambda) \frac{1}{\mu} (\mathbf{Y}_i^H[k] \mathbf{E}_2[k] - \mathbf{Y}_i^{n,H}[k] \mathbf{E}_1[k])$$

(equation 66)

with

$$\mathbf{E}[k] = \mathbf{F}\mathbf{k}^T \left(\mathbf{y}_0^n[k] - \mathbf{k}\mathbf{F}^{-1} \sum_{j=M-N}^{M-1} \mathbf{Y}_j^n[k] \mathbf{W}_j[k] \right); \quad (\text{equation 67})$$

$$\mathbf{E}_1[k] = \mathbf{F}\mathbf{k}^T \mathbf{k}\mathbf{F}^{-1} \sum_{j=M-N}^{M-1} \mathbf{Y}_j^n[k] \mathbf{W}_j[k]; \quad (\text{equation 68})$$

$$\mathbf{E}_2[k] = \mathbf{F}\mathbf{k}^T \mathbf{k}\mathbf{F}^{-1} \sum_{j=M-N}^{M-1} \mathbf{Y}_j[k] \mathbf{W}_j[k]. \quad (\text{equation 69})$$

5 and $\Lambda[k]$ computed as follows:

$$\Lambda[k] = \frac{2\rho'}{L} \text{diag} \{ P_0^{-1}[k], \dots, P_{2L-1}^{-1}[k] \} \quad (\text{equation 70})$$

$$P_m[k] = \gamma P_m[k-1] + (1-\gamma)(P_{1,m}[k] + P_{2,m}[k]) \quad (\text{equation 71})$$

$$P_{1,m}[k] = \sum_{j=M-N}^{M-1} |\mathbf{Y}_{j,m}^n[k]|^2 \quad (\text{equation 72})$$

$$P_{2,m}[k] = \lambda P_{2,m}[k-1] + (1-\lambda) \frac{1}{\mu} \left| \sum_{j=M-N}^{M-1} \left(|\mathbf{Y}_{j,m}[k]|^2 - |\mathbf{Y}_{j,m}^n[k]|^2 \right) \right|. \quad (\text{equation 73})$$

10 Compared to Algorithm 1, (eq.66) - (eq.69) require one extra $2L$ -point FFT and $8NL-2N-2L$ extra MAC per L samples and additional memory storage of a $2NL \times 1$ real data vector. To obtain the same time constant in the averaging operation as in the time-domain version with $K=1$, λ should equal $\frac{1}{\mu}$.

15 The experimental results that follow will show that the performance of the stochastic gradient algorithm is significantly improved by the low pass filter, especially for large λ .

[0081] Now the computational complexity of the
 20 different stochastic gradient algorithms is discussed. Table 1 summarises the computational complexity (expressed as the number of real multiply-accumulates (MAC), divisions (D), square roots (Sq) and absolute values (Abs)) of the time-domain (TD) and the frequency-domain (FD) Stochastic
 25 Gradient (SG) based algorithms. Comparison is made with standard NLMS and the NLMS based SPA. One complex multiplication is assumed to be equivalent to 4 real

multiplications and 2 real additions. A $2L$ -point FFT of a real input vector requires $2L \log_2 2L$ real MAC (assuming a radix-2 FFT algorithm).

Table 1 indicates that the TD-SG algorithm without filter w_0 and the SPA are about twice as complex as the standard ANC. When applying a Low Pass filter (LP) to the regularisation term, the TD-SG algorithm has about three times the complexity of the ANC. The increase in complexity of the frequency-domain implementations is less.

	Algorithm	update formula	step size adaptation
TD	NLMS ANC	$(2M - 2)L + 1$ MAC	$1D + (M - 1)L$ MAC
	NLMS based SPA	$4(M - 1)L + 1$ MAC + 1D + 1Sq	$1D + (M - 1)L$ MAC
	SG	$(4NL + 5)$ MAC	$1D + 1Abs + (2NL + 2)$ MAC
	SG with LP	$(7NL + 4)$ MAC	$1D + 1Abs + (2NL + 4)$ MAC
FD	NLMS ANC	$(10M - 7 - \frac{4(M-1)}{L}) + (6M - 2) \log_2 2L$ MAC	$1D + (2M + 2)$ MAC
	NLMS based SPA	$14M - 11 - \frac{4(M-1)}{L} + (6M - 2) \log_2 2L$ MAC + $1/L$ Sq + $1/LD$	$1D + (2M + 2)$ MAC
	SG (Algorithm 1)	$(18N + 6 - \frac{8N}{L}) + (6N + 8) \log_2 2L$ MAC	$1D + 1Abs + (4N + 4)$ MAC
	SG with LP (Algorithm 2)	$(26N + 4 - \frac{10N}{L}) + (6N + 10) \log_2 2L$ MAC	$1D + 1Abs + (4N + 6)$ MAC

10

Table 1

[0082] As an illustration, Fig. 9 plots the complexity (expressed as the number of Mega operations per second (Mops)) of the time-domain and the frequency-domain stochastic gradient algorithm with LP filter as a function of L for $M=3$ and a sampling frequency $f_s=16$ kHz. Comparison is made with the NLMS-based ANC of the GSC and the SPA. The complexity of the FD SPA is not depicted, since for small M , it is comparable to the cost of the FD-NLMS ANC. For

15

$L > 8$, the frequency-domain implementations result in a significantly lower complexity compared to their time-domain equivalents. The computational complexity of the FD stochastic gradient algorithm with LP is limited, making it
5 a good alternative to the SPA for implementation in hearing aids.

In Table 1 and Fig. 9 the complexity of the time-domain and the frequency-domain NLMS ANC and NLMS based SPA represents the complexity when the adaptive filter is only updated
10 during noise only. If the adaptive filter is also updated during speech + noise using data from a noise buffer, the time-domain implementations additionally require NL MAC per sample and the frequency-domain implementations additionally require 2 FFT and $(4L(M-1) - 2(M-1) + L)$ MAC per L
15 samples.

[0083] The performance of the different FD stochastic gradient implementations of the SP-SDW-MWF is evaluated based on experimental results for a hearing aid application. Comparison is made with the FD-NLMS based SPA.
20 For a fair comparison, the FD-NLMS based SPA is -like the stochastic gradient algorithms- also adapted during speech + noise using data from a noise buffer.

[0084] The set-up is the same as described before (see also Fig. 5). The performance of the FD stochastic
25 gradient algorithms is evaluated for a filter length $L=32$ taps per channel, $\rho'=0.8$ and $\gamma=0$. To exclude the effect of the spatial pre-processor, the performance measures are calculated w.r.t. the output of the fixed beamformer. The sensitivity of the algorithms against errors in the assumed
30 signal model is illustrated for microphone mismatch, e.g. a gain mismatch $\Upsilon_2=4$ dB of the second microphone.

[0085] Fig. 10(a) and (b) compare the performance of the different FD Stochastic Gradient (SG) SP-SDW-MWF

algorithms without \mathbf{w}_0 (i.e., the SDR-GSC) as a function of the trade-off parameter μ for a stationary and a non-stationary (e.g. multi-talker babble) noise source, respectively, at 90° . To analyse the impact of the approximation (eq.50) on the performance, the result of a FD implementation of (eq.49), which uses the clean speech, is depicted too. This algorithm is referred to as optimal FD-SG algorithm. Without Low Pass (LP) filter, the stochastic gradient algorithm achieves a worse performance than the optimal FD-SG algorithm (eq.49), especially for large $1/\mu$. For a stationary speech-like noise source, the FD-SG algorithm does not suffer too much from approximation (eq.50). In a highly time-varying noise scenario, such as multi-talker babble, the limited averaging of $\mathbf{r}[k]$ in the FD implementation does not suffice to maintain the large noise reduction achieved by (eq.49). The loss in noise reduction performance could be reduced by decreasing the step size ρ' , at the expense of a reduced convergence speed. Applying the low pass filter (eq.66) with e.g. $\lambda=0.999$ significantly improves the performance for all $1/\mu$, while changes in the noise scenario can still be tracked.

[0086] Fig. 11 plots the SNR improvement $\Delta\text{SNR}_{\text{intellig}}$ and the speech distortion $\text{SD}_{\text{intellig}}$ of the SP-SDW-MWF ($1/\mu=0.5$) with and without filter \mathbf{w}_0 for the babble noise scenario as a function of $\frac{1}{1-\lambda}$ where λ is the exponential weighting factor of the LP filter (see (eq.66)). Performance clearly improves for increasing λ . For small λ , the SP-SDW-MWF with \mathbf{w}_0 suffers from a larger excess error - and hence worse $\Delta\text{SNR}_{\text{intellig}}$ - compared to the SP-SDW-MWF without \mathbf{w}_0 . This is due to the larger dimensions of $E\{\mathbf{y}^s \mathbf{y}^{s,H}\}$.

[0087] The LP filter reduces fluctuations in the filter weights $\mathbf{W}_i[k]$ caused by poor estimates of the short-

term speech correlation matrix $E\{\mathbf{y}^s \mathbf{y}^{s,H}\}$ and/or by the highly non-stationary short-term speech spectrum. In contrast to a decrease in step size ρ' , the LP filter does not compromise tracking of changes in the noise scenario.

5 As an illustration, Fig. 12 plots the convergence behaviour of the FD stochastic gradient algorithm without \mathbf{w}_0 (i.e. the SDR-GSC) for $\lambda=0$ and $\lambda=0.9998$, respectively, when the noise source position suddenly changes from 90° to 180° . A gain mismatch Υ_2 of 4 dB was applied to the second

10 microphone. To avoid fast fluctuations in the residual noise energy ε_n^2 and the speech distortion energy ε_d^2 , the desired and the interfering noise source in this experiment are stationary, speech-like. The upper figure depicts the residual noise energy ε_n^2 as a function of the number of

15 input samples, the lower figure plots the residual speech distortion ε_d^2 during speech + noise periods as a function of the number of speech + noise samples. Both algorithms (i.e., $\lambda=0$ and $\lambda=0.9998$) have about the same convergence rate. When the change in position occurs, the algorithm

20 with $\lambda=0.9998$ even converges faster. For $\lambda=0$, the approximation error (eq.50) remains large for a while since the noise vectors in the buffer are not up to date. For $\lambda=0.9998$, the impact of the instantaneous large approximation error is reduced thanks to the low pass

25 filter.

[0088] Fig. 13 and Fig. 14 compare the performance of the FD stochastic gradient algorithm with LP filter ($\lambda=0.9998$) and the FD-NLMS based SPA in a multiple noise

30 talker babble noise sources positioned at angles $75^\circ, 120^\circ, 180^\circ, 240^\circ, 285^\circ$ w.r.t. the desired source at 0° . To assess the sensitivity of the algorithms against errors in the assumed signal model, the influence of microphone

mismatch, i.e. gain mismatch $\gamma_2=4\text{dB}$ of the second microphone, on the performance is depicted too. In Fig. 13, the SNR improvement $\Delta\text{SNR}_{\text{intellig}}$ and the speech distortion $\text{SD}_{\text{intellig}}$ of the SP-SDW-MWF with and without filter \mathbf{w}_0 is depicted as a function of the trade-off parameter $1/\mu$. Fig. 14 shows the performance of the QIC-GSC

$$\mathbf{w}^H \mathbf{w} \leq \beta^2 \quad (\text{equation 74})$$

for different constraint values β^2 , which is implemented using the FD-NLMS based SPA.

- 10 The SPA and the stochastic gradient based SP-SDW-MWF both increase the robustness of the GSC (i.e., the SP-SDW-MWF without \mathbf{w}_0 and $1/\mu=0$). For a given maximum allowable speech distortion $\text{SD}_{\text{intellig}}$, the SP-SDW-MWF with and without \mathbf{w}_0 achieve a better noise reduction performance than the SPA.
- 15 The performance of the SP-SDW-MWF with \mathbf{w}_0 is -in contrast to the SP-SDW-MWF without \mathbf{w}_0 - not affected by microphone mismatch. In the absence of model errors, the SP-SDW-MWF with \mathbf{w}_0 achieves a slightly worse performance than the SP-SDW-MWF without \mathbf{w}_0 . This can be explained by the fact that
- 20 with \mathbf{w}_0 , the estimate of $\frac{1}{\mu}E\{\mathbf{y}^s \mathbf{y}^{s,H}\}$ is less accurate due to the larger dimensions of $\frac{1}{\mu}E\{\mathbf{y}^s \mathbf{y}^{s,H}\}$ (see also Fig. 11). In conclusion, the proposed stochastic gradient implementation of the SP-SDW-MWF preserves the benefit of the SP-SDW-MWF over the QIC-GSC.

25

Improvement 2 : frequency-domain stochastic gradient algorithm using correlation matrices

- [0089] It is now shown that by approximating the regularisation term in the frequency-domain, (diagonal) speech and noise correlation matrices can be used instead of data buffers, such that the memory usage is decreased drastically, while also the computational complexity is
- 30

further reduced. Experimental results demonstrate that this approximation results in a small -positive or negative- performance difference compared to the stochastic gradient algorithm with low pass filter, such that the proposed
 5 algorithm preserves the robustness benefit of the SP-SDW-MWF over the QIC-GSC, while both its computational complexity and memory usage are now comparable to the NLMS-based SPA for implementing the QIC-GSC.

[0090] As the estimate of $\mathbf{r}[k]$ in (eq.51) proved to
 10 be quite poor, resulting in a large excess error, it was suggested in (eq. 59) to use an estimate of the average clean speech correlation matrix. This allows $\mathbf{r}[k]$ to be computed as

$$\mathbf{r}[k] = \frac{1}{\mu} (1 - \tilde{\lambda}) \sum_{l=0}^k \tilde{\lambda}^{k-l} (\mathbf{y}_{buf_1}[l] \mathbf{y}_{buf_1}^H[l] - \mathbf{y}^n[l] \mathbf{y}^{n,H}[l]) \cdot \mathbf{w}[k], \quad (\text{equation 75})$$

15 with $\tilde{\lambda}$ an exponential weighting factor. For stationary noise a small $\tilde{\lambda}$, i.e. $1/(1-\tilde{\lambda}) \sim NL$, suffices. However, in practice the speech and the noise signals are often spectrally highly non-stationary (e.g. multi-talker babble noise), whereas their long-term spectral and spatial
 20 characteristics usually vary more slowly in time. Spectrally highly non-stationary noise can still be spatially suppressed by using an estimate of the long-term correlation matrix in $\mathbf{r}[k]$, i.e. $1/(1-\tilde{\lambda}) \gg NL$.

In order to avoid expensive matrix operations for computing
 25 (eq.75), it was previously assumed that $\mathbf{w}[k]$ varies slowly in time, i.e. $\mathbf{w}[k] \approx \mathbf{w}[l]$, such that (eq.75) can be approximated with vector instead of matrix operations by directly applying a low pass filter to the regularisation term $\mathbf{r}[k]$, cf. (eq.63),

30
$$\mathbf{r}[k] = \frac{1}{\mu} (1 - \tilde{\lambda}) \sum_{l=0}^k \tilde{\lambda}^{k-l} (\mathbf{y}_{buf_1}[l] \mathbf{y}_{buf_1}^H[l] - \mathbf{y}^n[l] \mathbf{y}^{n,H}[l]) \cdot \mathbf{w}[l] \quad (\text{equation 76})$$

$$= \lambda[k-1] + (1-\lambda) \frac{1}{\mu} (\mathbf{y}_{buf_1}[k] \mathbf{y}_{buf_1}^H[k] - \mathbf{y}^n[k] \mathbf{y}^{n,H}[k]) \mathbf{w}[k]. \quad (\text{equation 77})$$

However, this assumption is actually not required in a frequency-domain implementation, as will now be shown.

[0091] The frequency-domain algorithm called
 5 Algorithm 2 requires large data buffers and hence the storage of a large amount of data (note that to achieve a good performance, typical values for the buffer lengths of the circular buffers \mathbf{B}_1 and \mathbf{B}_2 are 10000...20000). A substantial memory (and computational complexity) reduction
 10 can be achieved by the following two steps:

- When using (eq.75) instead of (eq.77) for calculating the regularisation term, correlation matrices instead of data samples need to be stored. The frequency-domain implementation of the resulting
 15 algorithm is summarised in Algorithm 3, where $2L \times 2L$ -dimensional speech and noise correlation matrices $\mathbf{S}_{ij}[k]$ and $\mathbf{S}_{ij}^n[k], i, j = M-N \dots M-1$ are used for calculating the regularisation term $\mathbf{R}_i[k]$ and (part of) the step size $\Lambda[k]$. These correlation matrices are updated
 20 respectively during speech + noise periods and noise only periods. When using correlation matrices, filter adaptation can only take place during noise only periods, since during speech + noise periods the desired signal cannot be constructed from the noise
 25 buffer \mathbf{B}_2 anymore. This first step however does not necessarily reduce the memory usage (NL_{buf1} for data buffers vs. $2(NL)^2$ for correlation matrices) and will even increase the computational complexity, since the correlation matrices are not diagonal.

- The correlation matrices in the frequency-domain can be approximated by diagonal matrices, since $\mathbf{F} \mathbf{k}^T \mathbf{k} \mathbf{F}^{-1}$
 30 in Algorithm 3 can be well approximated by $\mathbf{I}_{2L}/2$.

Hence, the speech and the noise correlation matrices are updated as

$$\mathbf{S}_{ij}[k] = \lambda \mathbf{S}_{ij}[k-1] + (1-\lambda) \mathbf{Y}_i^H[k] \mathbf{Y}_j[k] / 2, \quad (\text{equation 78})$$

$$\mathbf{S}_{ij}^n[k] = \lambda \mathbf{S}_{ij}^n[k-1] + (1-\lambda) \mathbf{Y}_i^{n,H}[k] \mathbf{Y}_j^n[k] / 2, \quad (\text{equation 79})$$

- 5 leading to a significant reduction in memory usage and computational complexity, while having a minimal impact on the performance and the robustness. This algorithm will be referred to as Algorithm 4.

Algorithm 3 Frequency-domain implementation with correlation matrices (without approximation)

Initialisation and matrix definitions:

$$\begin{aligned} \mathbf{W}_i[0] &= [0 \quad L \quad 0]^T, i = M - N \dots M - 1 \\ 5 \quad P_m[0] &= \delta_m, m = 0 \dots 2L - 1 \\ \mathbf{F} &= 2L \times 2L \text{-dimensional DFT matrix} \\ \mathbf{g} &= \begin{bmatrix} \mathbf{I}_L & \mathbf{0}_L \\ \mathbf{0}_L & \mathbf{0}_L \end{bmatrix}, \quad \mathbf{k} = [\mathbf{0}_L \quad \mathbf{I}_L] \end{aligned}$$

$\mathbf{0}_L = L \times L$ -dim. zero matrix, $\mathbf{I}_L = L \times L$ -dim. identity matrix

For each new block of L samples (per channel):

$$\begin{aligned} 10 \quad \mathbf{d}[k] &= [y_0[kL - \Delta] \quad L \quad y_0[kL - \Delta + L - 1]]^T \\ \mathbf{Y}_i[k] &= \text{diag} \left\{ \mathbf{F} [y_i[kL - L] \quad L \quad y_i[kL + L - 1]]^T \right\}, i = M - N \dots M - 1 \end{aligned}$$

Output signal:

$$\mathbf{e}[k] = \mathbf{d}[k] - \mathbf{k} \mathbf{F}^{-1} \sum_{j=M-N}^{M-1} \mathbf{Y}_j[k] \mathbf{W}_j[k], \quad \mathbf{E}[k] = \mathbf{F} \mathbf{k}^T \mathbf{e}[k]$$

If speech detected:

$$15 \quad \mathbf{S}_{ij}[k] = (1 - \lambda) \sum_{l=0}^k \lambda^{k-l} \mathbf{Y}_i^H[l] \mathbf{F} \mathbf{k}^T \mathbf{k} \mathbf{F}^{-1} \mathbf{Y}_j[l] = \lambda \mathbf{S}_{ij}[k-1] + (1 - \lambda) \mathbf{Y}_i^H[k] \mathbf{F} \mathbf{k}^T \mathbf{k} \mathbf{F}^{-1} \mathbf{Y}_j[k]$$

If noise detected: $\mathbf{Y}_i[k] = \mathbf{Y}_i^n[k]$

$$\mathbf{S}_{ij}^n[k] = (1 - \lambda) \sum_{l=0}^k \lambda^{k-l} \mathbf{Y}_i^{n,H}[l] \mathbf{F} \mathbf{k}^T \mathbf{k} \mathbf{F}^{-1} \mathbf{Y}_j^n[l] = \lambda \mathbf{S}_{ij}^n[k-1] + (1 - \lambda) \mathbf{Y}_i^{n,H}[k] \mathbf{F} \mathbf{k}^T \mathbf{k} \mathbf{F}^{-1} \mathbf{Y}_j^n[k]$$

Update formula (only during noise-only-periods):

$$\begin{aligned} \mathbf{R}_i[k] &= \frac{1}{\mu} \sum_{j=M-N}^{M-1} [\mathbf{S}_{ij}[k] - \mathbf{S}_{ij}^n[k]] \mathbf{W}_j[k], i = M - N \dots M - 1 \\ 20 \quad \mathbf{W}_i[k+1] &= \mathbf{W}_i[k] + \mathbf{F} \mathbf{g} \mathbf{F}^{-1} \Lambda[k] \left\{ \mathbf{Y}_i^{n,H}[k] \mathbf{E}[k] - \mathbf{R}_i[k] \right\}, i = M - N \dots M - 1 \end{aligned}$$

with

$$\begin{aligned} \Lambda[k] &= \frac{2\rho'}{L} \text{diag} \{ P_0^{-1}[k], \dots, P_{2L-1}^{-1}[k] \} \\ P_m[k] &= \gamma P_m[k-1] + (1 - \gamma) (P_{1,m}[k] + P_{2,m}[k]), m = 0 \dots 2L - 1 \\ P_{1,m}[k] &= \sum_{j=M-N}^{M-1} |Y_{j,m}^n[k]|^2, P_{2,m}[k] = \frac{1}{\mu} \left| \sum_{j=M-N}^{M-1} S_{jj,m}[k] - S_{jj,m}^n[k] \right|, m = 0 \dots 2L - 1 \end{aligned}$$

[0092] Table 2 summarises the computational complexity and the memory usage of the frequency-domain NLMS-based SPA for implementing the QIC-GSC and the frequency-domain stochastic gradient algorithms for implementing the SP-SDW-MWF (Algorithm 2 and Algorithm 4). The computational complexity is again expressed as the number of Mega operations per second (Mops), while the memory usage is expressed in kWords. The following parameters have been used: $M=3$, $L=32$, $f_s=16\text{kHz}$, $L_{buf1}=10000$,
10 (a) $N=M-1$, (b) $N=M$. From this table the following conclusions can be drawn:

- The computational complexity of the SP-SDW-MWF (Algorithm 2) with filter w_0 is about twice the complexity of the QIC-GSC (and even less if the filter w_0 is not used). The approximation of the regularisation term in Algorithm 4 further reduces the computational complexity. However, this only remains true for a small number of input channels, since the approximation introduces a quadratic term $O(N^2)$.
- Due to the storage of data samples in the circular speech + noise buffer B_1 , the memory usage of the SP-SDW-MWF (Algorithm 2) is quite high in comparison with the QIC-GSC (depending on the size of the data buffer L_{buf1} of course). By using the approximation of the regularisation term in Algorithm 4, the memory usage can be reduced drastically, since now diagonal correlation matrices instead of data buffers need to be stored. Note however that also for the memory usage a quadratic term $O(N^2)$ is present.

Algorithm	Computational complexity		Mops
	update formula	step size adaptation	
NLMS based SPA	$(14M - 11 - \frac{4(M-1)}{L}) + (6M - 2) \log_2 2L$ $MAC + 1/L Sq + 1/L D$	$(2M + 2) MAC + 1D$	2.16
SG with LP (Algorithm 2)	$(26N + 4 - \frac{10N}{L}) + (6N + 10) \log_2 2L$ MAC	$(4N + 6) MAC + 1D + 1Abs$	3.22 ^(a) , 4.27 ^(b)
SG with correlation matrices (Algorithm 4)	$(10N^2 + 13N - \frac{4N^2 + 3N}{L}) + (6N + 4) \log_2 2L$ MAC	$(2N + 4) MAC + 1D + 1Abs$	2.71 ^(a) , 4.31 ^(b)
	Memory usage		kWords
NLMS based SPA	$4(M - 1)L + 6L$		0.45
SG with LP (Algorithm 2)	$2NL_{buf_1} + 6LN + 7L$		40.61 ^(a) , 60.80 ^(b)
SG with correlation matrices (Algorithm 4)	$4LN^2 + 6LN + 7L$		1.12 ^(a) , 1.95 ^(b)

Table 2

[0093] It is now shown that practically no performance difference exists between Algorithm 2 and
5 Algorithm 4, such that the SP-SDW-MWF using the implementation with (diagonal) correlation matrices still preserves its robustness benefit over the GSC (and the QIC-GSC). The same set-up has been used as for the previous experiments.

10 The performance of the stochastic gradient algorithms in the frequency-domain is evaluated for a filter length $L=32$ per channel, $\rho'=0.8$, $\gamma=0.95$ and $\lambda=0.9998$. For all considered algorithms, filter adaptation only takes place during noise only periods. To exclude the effect of the
15 spatial pre-processor, the performance measures are calculated with respect to the output of the fixed beamformer. The sensitivity of the algorithms against errors in the assumed signal model is illustrated for

microphone mismatch, i.e. a gain mismatch $\gamma_2=4$ dB at the second microphone.

[0094] Fig. 15 and Fig. 16 depict the SNR improvement $\Delta\text{SNR}_{\text{intellig}}$ and the speech distortion $\text{SD}_{\text{intellig}}$ of the SP-SDW-MWF (with \mathbf{w}_0) and the SDR-GSC (without \mathbf{w}_0), implemented using Algorithm 2 (solid line) and Algorithm 4 (dashed line), as a function of the trade-off parameter $1/\mu$. These figures also depict the effect of a gain mismatch $\gamma_2=4$ dB at the second microphone. From these figures it can be observed that approximating the regularisation term in the frequency-domain only results in a small performance difference. For most scenarios the performance is even better (i.e. larger SNR improvement and smaller speech distortion) for Algorithm 4 than for Algorithm 2.

[0095] Hence, also when implementing the SP-SDW-MWF using the proposed Algorithm 4, it still preserves its robustness benefit over the GSC (and the QIC-GSC). E.g. it can be observed that the GSC (i.e. SDR-GSC with $1/\mu=0$) will result in a large speech distortion (and a smaller SNR improvement) when microphone mismatch occurs. Both the SDR-GSC and the SP-SDW-MWF add robustness to the GSC, i.e. the distortion decreases for increasing $1/\mu$. The performance of the SP-SDW-MWF (with \mathbf{w}_0) is again hardly affected by microphone mismatch.

CLAIMS

1. Method to reduce noise in a noisy speech signal, comprising the steps of
- applying at least two versions of said noisy speech signal to a first filter, said first filter outputting a speech reference signal and at least one noise reference signal,
 - applying a filtering operation to each of said at least one noise reference signals, and
 - subtracting from said speech reference signal each of said filtered noise reference signals,
- characterised in that said filtering operation is performed with filters having filter coefficients determined by taking into account speech leakage contributions in said at least one noise reference signal.
2. Method to reduce noise as in claim 1, wherein said at least two versions of said noisy speech signal are signals from at least two microphones picking up said noisy speech signal.
3. Method to reduce noise as in claim 1 or 2, wherein said first filter is a spatial pre-processor filter, comprising a beamformer filter and a blocking matrix filter.
4. Method to reduce noise as in claim 3, wherein said speech reference signal is output by said beamformer filter and said at least one noise reference signal is output by said blocking matrix filter.
5. Method to reduce noise as in any of the previous claims, wherein said speech reference signal is delayed before performing the subtraction step.
6. Method to reduce noise as in any of the previous claims, wherein additionally a filtering operation is applied to said speech reference signal and wherein said

filtered speech reference signal is also subtracted from said speech reference signal.

7. Method to reduce noise as in any of the previous claims, further comprising the step of regularly
5 adapting said filter coefficients, thereby taking into account said speech leakage contributions in said at least one noise reference signal or taking into account said speech leakage contributions in said at least one noise reference signal and said speech contribution in said
10 speech reference signal.

8. Use of a method to reduce noise as in any of the previous claims in a speech enhancement application.

9. Signal processing circuit for reducing noise in a noisy speech signal, comprising
15 • a first filter, said first filter having at least two inputs and being arranged for outputting a speech reference signal and at least one noise reference signal,
• a filter to apply said speech reference signal to and
20 filters to apply each of said at least one noise reference signals to, and
• summation means for subtracting from said speech reference signal said filtered speech reference signal and each of said filtered noise reference signals.

25 10. Signal processing circuit as in claim 9, wherein said first filter is a spatial pre-processor filter, comprising a beamformer filter and a blocking matrix filter.

30 11. Signal processing circuit as in claim 10, wherein said beamformer filter is a delay-and-sum beamformer.

12. Hearing device comprising a signal processing circuit as in any of the claims 9 to 11.

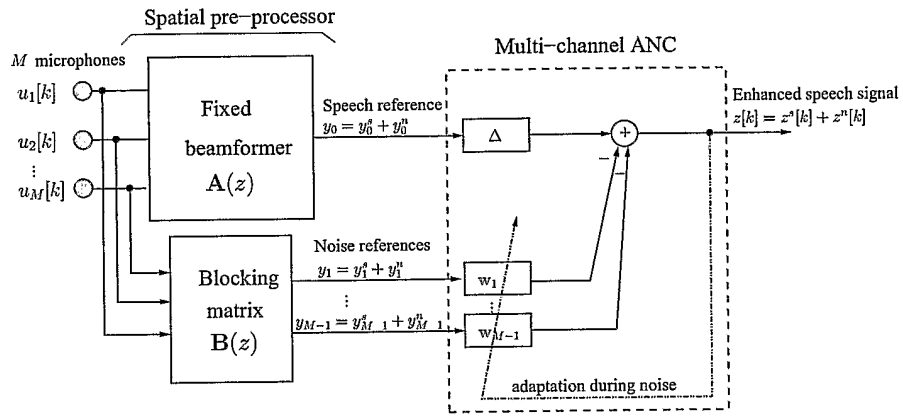

Fig. 1

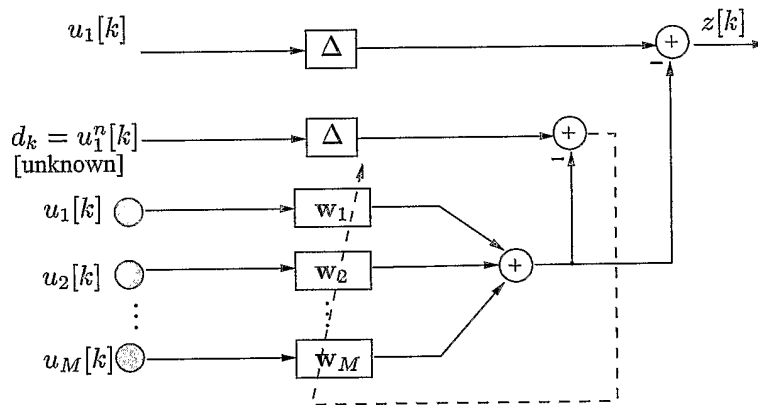

Fig. 2

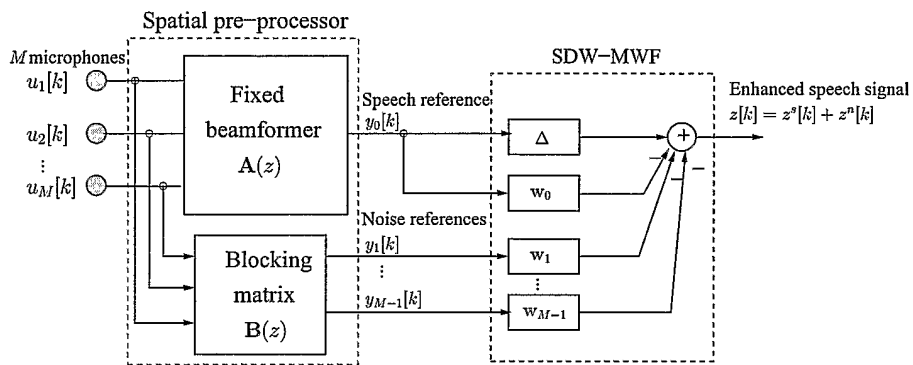

Fig. 3

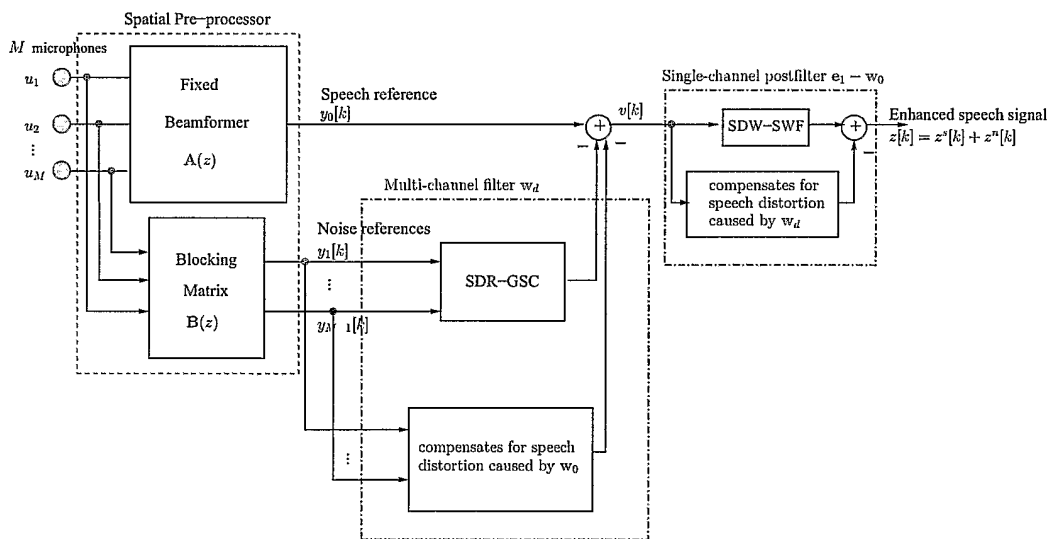

Fig. 4

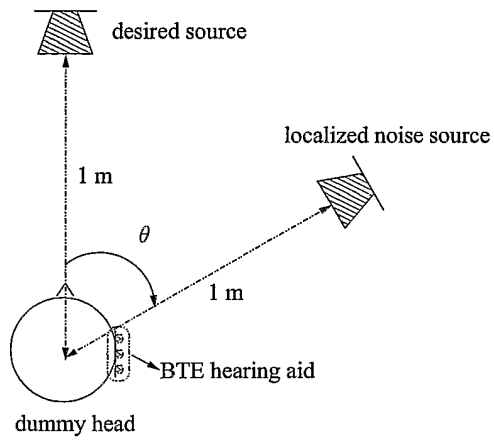

Fig. 5

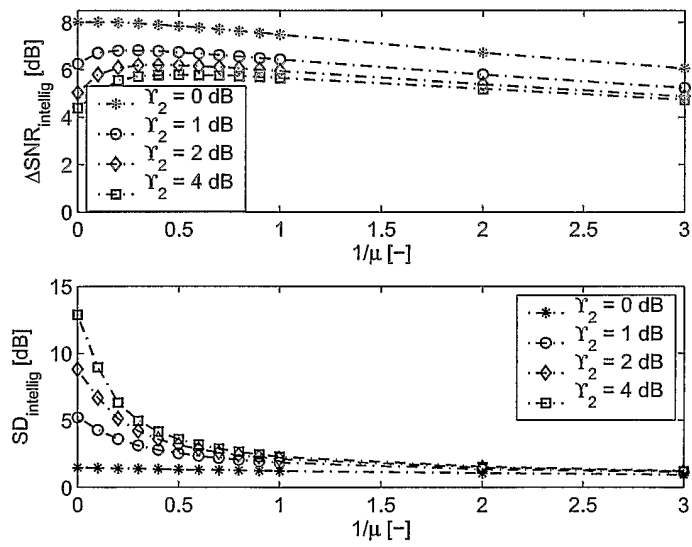

Fig. 6

4/8

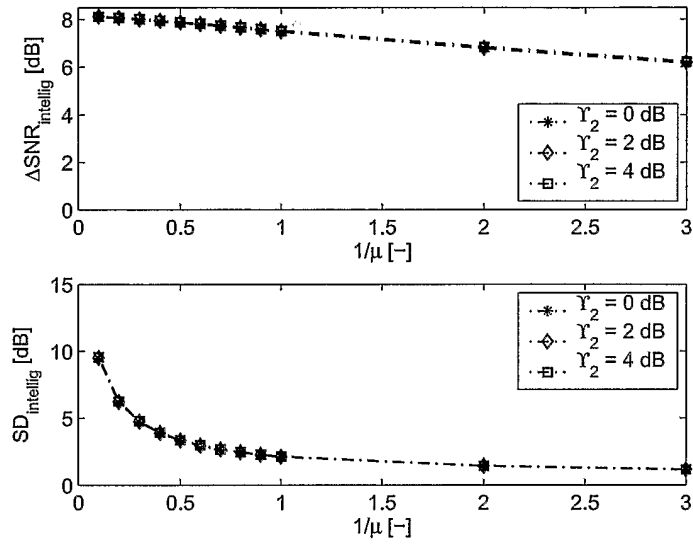

Fig. 7

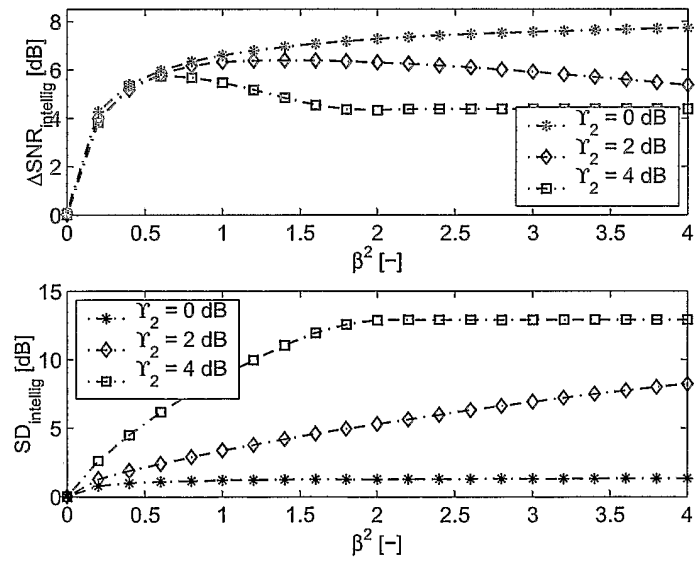

Fig. 8

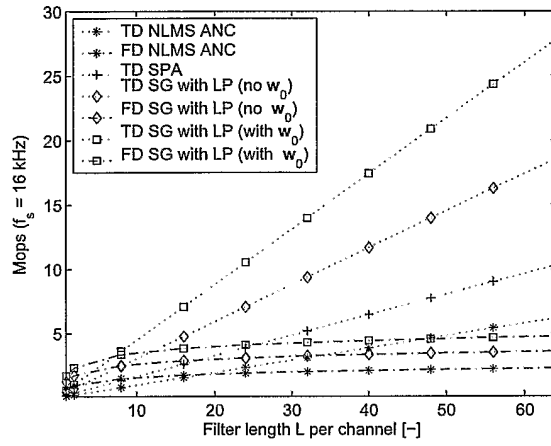

Fig. 9

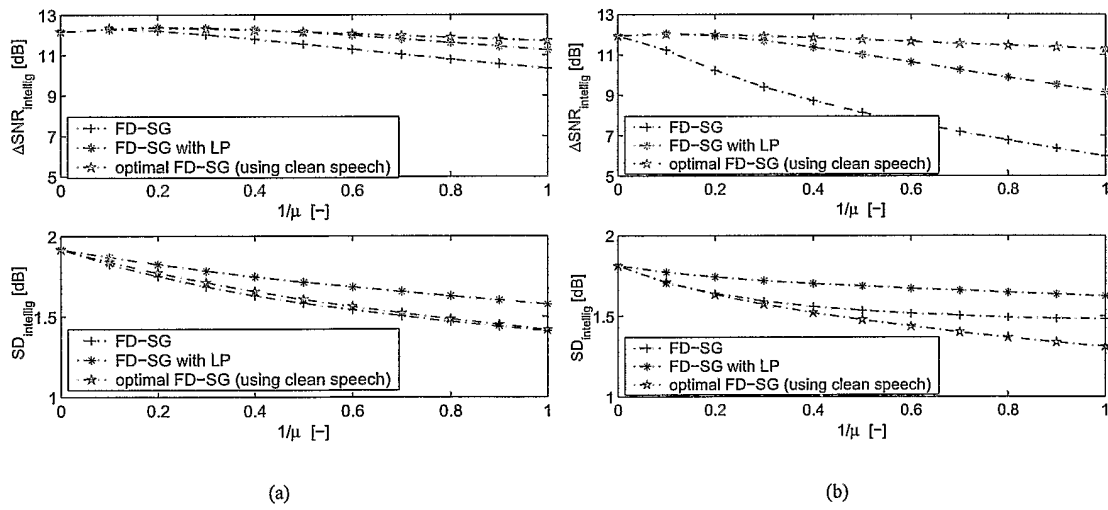

Fig. 10

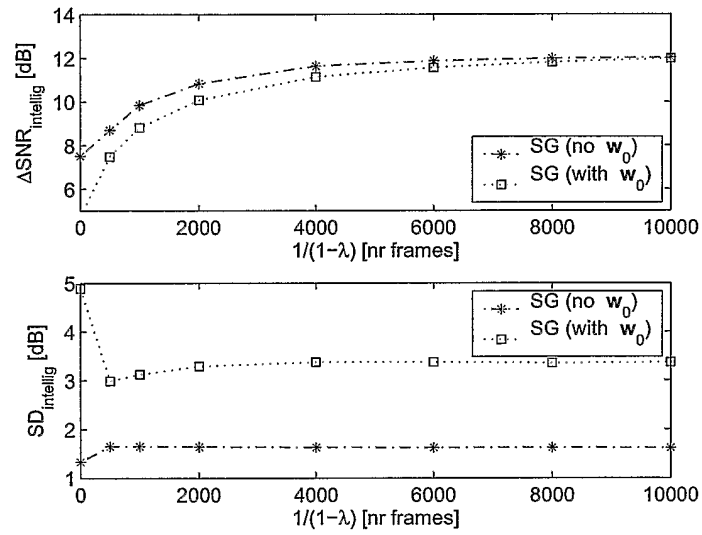

Fig. 11

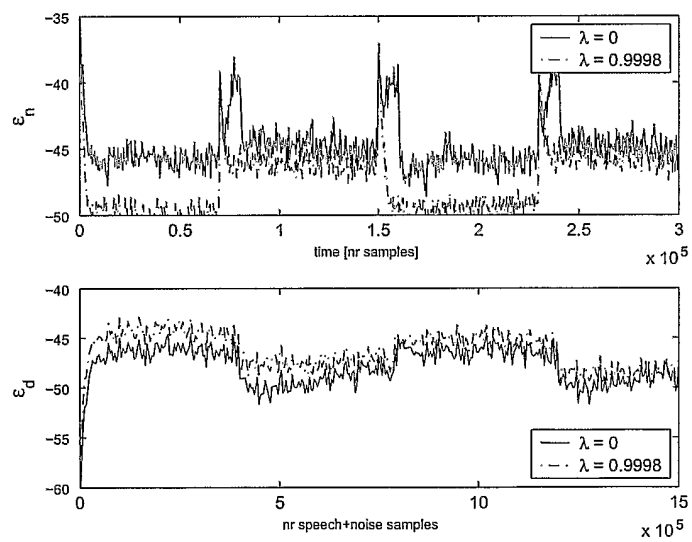

Fig. 12

7/8

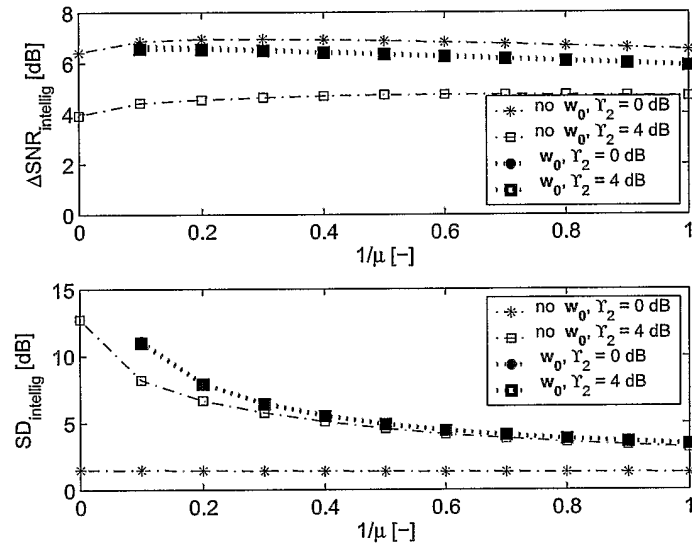

Fig. 13

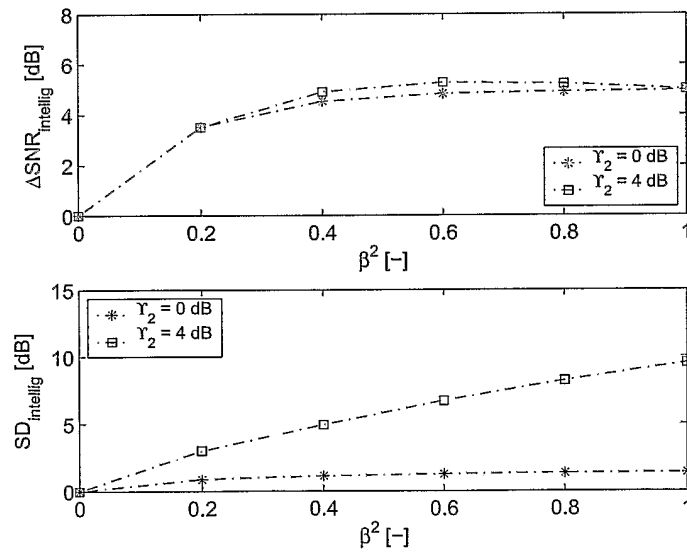

Fig. 14

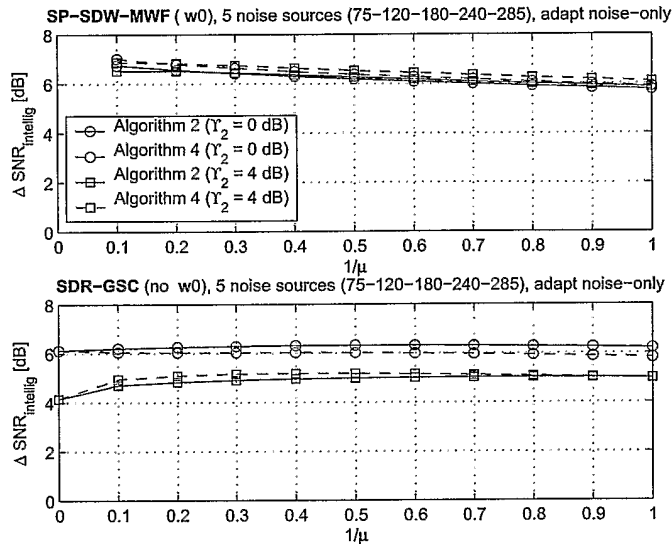

Fig. 15

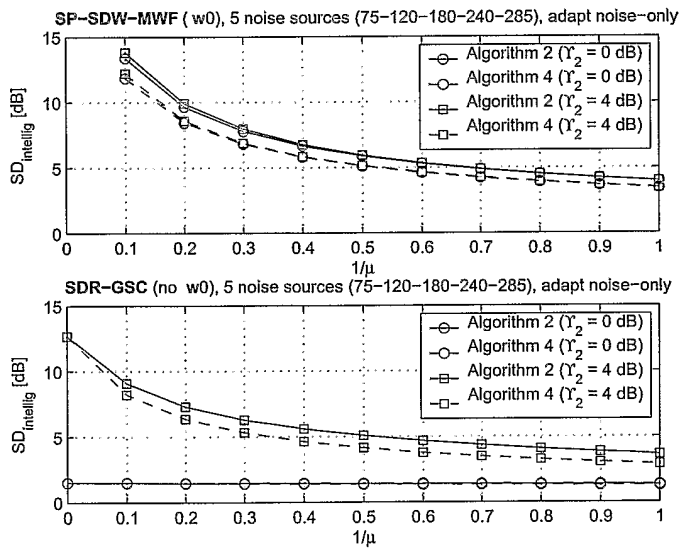

Fig. 16

INTERNATIONAL SEARCH REPORT

International Application No
PCT/BE2004/000103

A. CLASSIFICATION OF SUBJECT MATTER
IPC 7 H04R3/00 G10L21/02

According to International Patent Classification (IPC) or to both national classification and IPC

B. FIELDS SEARCHED

Minimum documentation searched (classification system followed by classification symbols)
IPC 7 G10L H04R

Documentation searched other than minimum documentation to the extent that such documents are included in the fields searched

Electronic data base consulted during the international search (name of data base and, where practical, search terms used)

EPO-Internal, WPI Data, PAJ, COMPENDEX, INSPEC

C. DOCUMENTS CONSIDERED TO BE RELEVANT

Category °	Citation of document, with indication, where appropriate, of the relevant passages	Relevant to claim No.
X	EP 0 700 156 A (NIPPON ELECTRIC CO) 6 March 1996 (1996-03-06) column 1, line 3 - column 3; claim 8 column 3, line 42 - column 9, line 21	1-5,7,8
Y		6,9-12
X	NEO W H ET AL: "Robust microphone arrays using subband adaptive filters" IEE PROCEEDINGS: VISION, IMAGE AND SIGNAL PROCESSING, INSTITUTION OF ELECTRICAL ENGINEERS, GB, vol. 149, no. 1, 21 February 2002 (2002-02-21), pages 17-25, XP006017903 ISSN: 1350-245X page 17 - page 21	1-5,7,8
Y		6,9-12

Further documents are listed in the continuation of box C.

Patent family members are listed in annex.

° Special categories of cited documents :

- *A* document defining the general state of the art which is not considered to be of particular relevance
- *E* earlier document but published on or after the international filing date
- *L* document which may throw doubts on priority claim(s) or which is cited to establish the publication date of another citation or other special reason (as specified)
- *O* document referring to an oral disclosure, use, exhibition or other means
- *P* document published prior to the international filing date but later than the priority date claimed

- *T* later document published after the international filing date or priority date and not in conflict with the application but cited to understand the principle or theory underlying the invention
- *X* document of particular relevance; the claimed invention cannot be considered novel or cannot be considered to involve an inventive step when the document is taken alone
- *Y* document of particular relevance; the claimed invention cannot be considered to involve an inventive step when the document is combined with one or more other such documents, such combination being obvious to a person skilled in the art.
- * & * document member of the same patent family

Date of the actual completion of the international search

22 November 2004

Date of mailing of the international search report

06/12/2004

Name and mailing address of the ISA
European Patent Office, P.B. 5818 Patentlaan 2
NL - 2280 HV Rijswijk
Tel. (+31-70) 340-2040, Tx. 31 651 epo nl,
Fax: (+31-70) 340-3016

Authorized officer

Peirs, K

INTERNATIONAL SEARCH REPORT

International Application No
PCT/BE2004/000103

C.(Continuation) DOCUMENTS CONSIDERED TO BE RELEVANT		
Category *	Citation of document, with indication, where appropriate, of the relevant passages	Relevant to claim No.
Y	US 2002/034310 A1 (HOU ZEZHANG) 21 March 2002 (2002-03-21) paragraph '0003! - paragraph '0016! -----	6,9-12
P,X	PROCEEDINGS OF THE 2003 INTERNATIONAL WORKSHOP ON ACOUSTIC ECHO AND NOISE CONTROL, 'Online! 8 September 2003 (2003-09-08), pages 147-150, XP002305847 SPATIALLY PRE-PROCESSED SPEECH DISTORTION WEIGHTED MULTI-CHANNEL WIENER FILTERING FOR NOISE REDUCTION IN HEARING AIDS Retrieved from the Internet: URL:http://www.kuleuven.ac.be/expor1/Lab/M embers/Spriet.php> 'retrieved on 2004-11-09! the whole document -----	1-12
A	US 5 953 380 A (IKEDA SHIGEJI) 14 September 1999 (1999-09-14) column 1, line 5 - column 4, line 56 column 5, line 6 - column 8, line 37 -----	1-12
A	OMOLOGO M ET AL: "Environmental conditions and acoustic transduction in hands-free speech recognition" SPEECH COMMUNICATION, AMSTERDAM, NL, vol. 25, no. 1-3, 1 August 1998 (1998-08-01), pages 75-95, XP004148066 ISSN: 0167-6393 page 76, column 1 - page 78, column 1 page 86, column 1 - page 88, column 1 -----	1-12
A	LIN L ET AL: "Speech denoising using perceptual modification of Wiener filtering" ELECTRONICS LETTERS, IEE STEVENAGE, GB, vol. 38, no. 23, 7 November 2002 (2002-11-07), pages 1486-1487, XP006019184 ISSN: 0013-5194 the whole document -----	1-12
A	LINK M J ET AL: "Robust real-time constrained hearing aid arrays" APPLICATIONS OF SIGNAL PROCESSING TO AUDIO AND ACOUSTICS, 1993. FINAL PROGRAM AND PAPER SUMMARIES., 1993 IEEE WORKSHOP ON NEW PALTZ, NY, USA 17-20 OCT. 1993, NEW YORK, NY, USA, IEEE, 17 October 1993 (1993-10-17), pages 81-84, XP010130073 ISBN: 0-7803-2078-6 the whole document -----	1-12

INTERNATIONAL SEARCH REPORT

Information on patent family members

International Application No

PCT/BE2004/000103

Patent document cited in search report	A	Publication date	Patent family member(s)	Publication date
EP 0700156	A	06-03-1996	CA 2157418 A1	02-03-1996
			DE 69526892 D1	11-07-2002
			DE 69526892 T2	19-12-2002
			EP 0700156 A2	06-03-1996
			JP 2720845 B2	04-03-1998
			JP 8122424 A	17-05-1996
			US 5627799 A	06-05-1997
US 2002034310	A1	21-03-2002	AU 4574001 A	24-09-2001
			CN 1418448 T	14-05-2003
			DE 10195933 T0	30-04-2003
			JP 2003527012 T	09-09-2003
			WO 0169968 A2	20-09-2001
US 5953380	A	14-09-1999	JP 2882364 B2	12-04-1999
			JP 10003298 A	06-01-1998
			CA 2207716 A1	14-12-1997