



US011128487B2

(12) **United States Patent**
Yamada

(10) **Patent No.:** **US 11,128,487 B2**
(45) **Date of Patent:** **Sep. 21, 2021**

(54) **CIRCUIT DEVICE, ELECTRONIC DEVICE, AND MOBILE BODY**

2012/40273; H04L 12/40013; H04L 7/0087; H03K 19/017509; B60R 16/023; G06F 1/266; G06F 13/4072

(71) Applicant: **SEIKO EPSON CORPORATION**, Tokyo (JP)

See application file for complete search history.

(72) Inventor: **Toshimichi Yamada**, Chino (JP)

(56) **References Cited**

(73) Assignee: **SEIKO EPSON CORPORATION**, Tokyo (JP)

U.S. PATENT DOCUMENTS

(*) Notice: Subject to any disclaimer, the term of this patent is extended or adjusted under 35 U.S.C. 154(b) by 189 days.

6,405,330 B1 * 6/2002 Hanf G05B 19/0423 714/712
8,421,501 B1 * 4/2013 Rien H03K 19/018521 326/81

(Continued)

(21) Appl. No.: **16/441,075**

FOREIGN PATENT DOCUMENTS

(22) Filed: **Jun. 14, 2019**

JP 2014-117077 A 6/2014

(65) **Prior Publication Data**

US 2019/0386846 A1 Dec. 19, 2019

OTHER PUBLICATIONS

Texas Instruments, "Voltage Level Translation Guide", 2011, Texas Instruments (Year: 2011).*

(30) **Foreign Application Priority Data**

Jun. 15, 2018 (JP) JP2018-114404

Primary Examiner — Paul H Masur

Assistant Examiner — Michael K Phillips

(74) Attorney, Agent, or Firm — Oliff PLC

(51) **Int. Cl.**

H04L 12/40 (2006.01)
H03K 19/0175 (2006.01)
H04L 29/08 (2006.01)
B60R 16/023 (2006.01)
H04L 7/00 (2006.01)
G06F 1/26 (2006.01)

(Continued)

(57) **ABSTRACT**

A circuit device includes a physical layer circuit coupled to a data bus, and a processing circuit that controls the physical layer circuit and performs communications processing through the data bus. The processing circuit operates with a voltage supplied from a ground line as a power supply voltage VSS on a low potential side, and the physical layer circuit operates based on a power supply voltage VSSA on the low potential side supplied from a power supply line not coupled to the ground line in the circuit device, and a power supply voltage HVDDA on a high potential side set with reference to the power supply voltage VSSA.

(52) **U.S. Cl.**

CPC **H04L 12/40** (2013.01); **B60R 16/023** (2013.01); **H03K 19/017509** (2013.01); **H04L 69/323** (2013.01); **G01R 19/165** (2013.01); **G01R 27/08** (2013.01); **G06F 1/266** (2013.01); **G06F 13/4072** (2013.01); **H04L 7/0087** (2013.01); **H04L 2012/40273** (2013.01)

(58) **Field of Classification Search**

CPC H04L 12/40; H04L 69/323; H04L

11 Claims, 13 Drawing Sheets

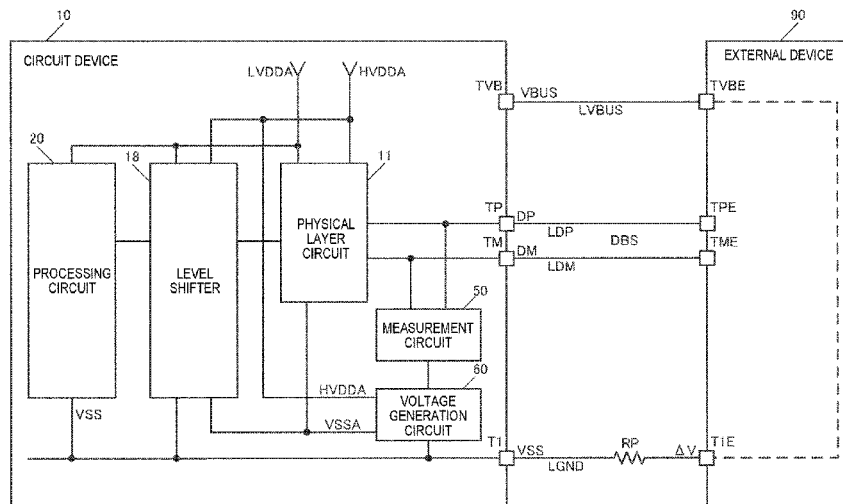

- (51) **Int. Cl.**
G06F 13/40 (2006.01)
G01R 27/08 (2006.01)
G01R 19/165 (2006.01)

(56) **References Cited**

U.S. PATENT DOCUMENTS

2010/0064148 A1* 3/2010 Ho H02J 1/00
713/300
2012/0044010 A1* 2/2012 Murakami H03K 19/017509
327/333
2012/0307931 A1* 12/2012 Johnson H04L 25/026
375/295
2013/0191566 A1* 7/2013 Kaestner G06F 13/426
710/104
2013/0285641 A1 10/2013 Mkrtychyan et al.
2015/0362944 A1* 12/2015 Sporck H02M 1/00
323/303
2016/0173092 A1* 6/2016 Trivedi H03K 19/017509
327/333
2016/0378154 A1 12/2016 Srivastava
2017/0025879 A1* 1/2017 Thompson G06F 1/266
2017/0366333 A1* 12/2017 Chan H04L 25/06

* cited by examiner

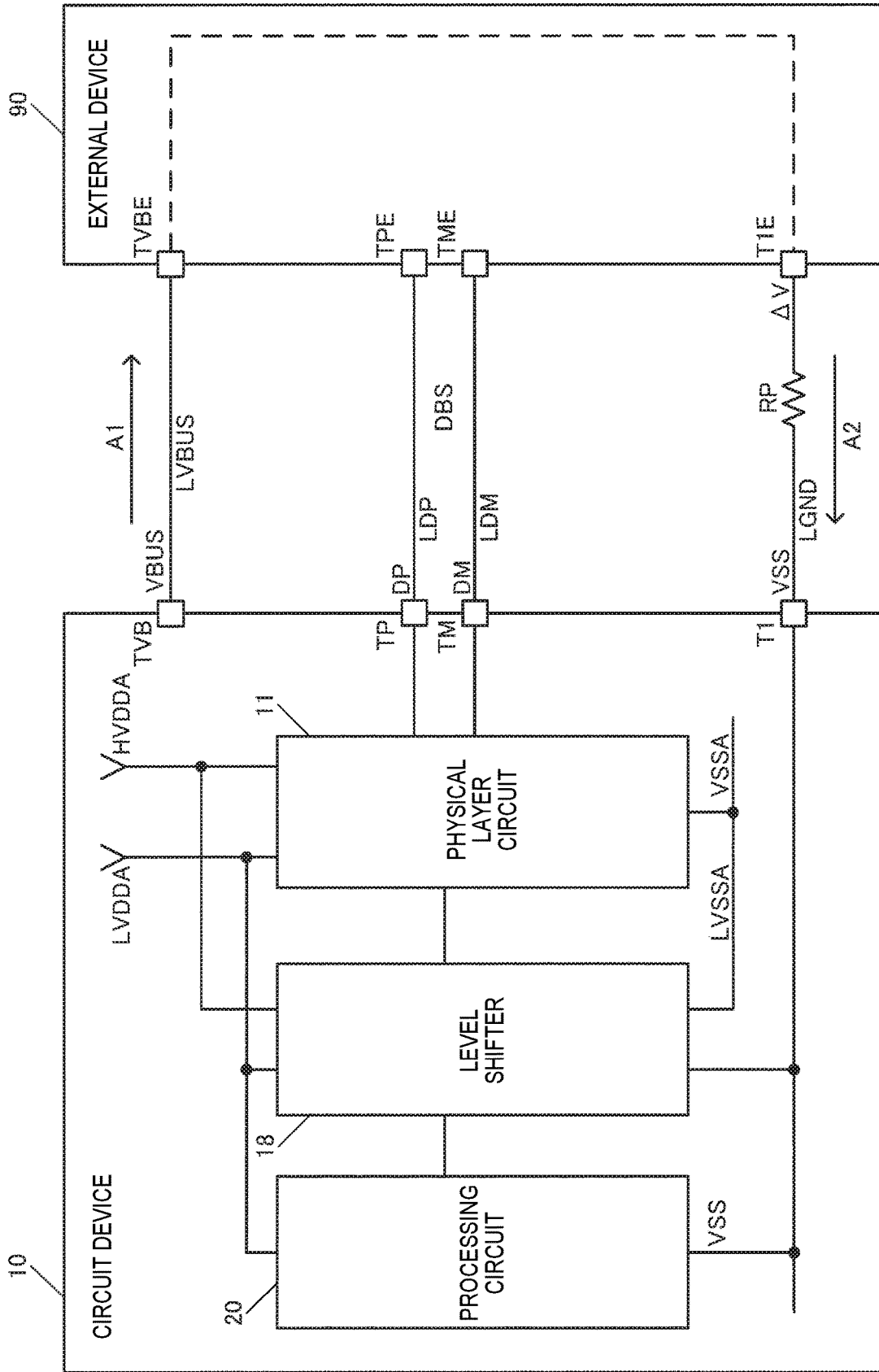

FIG. 1

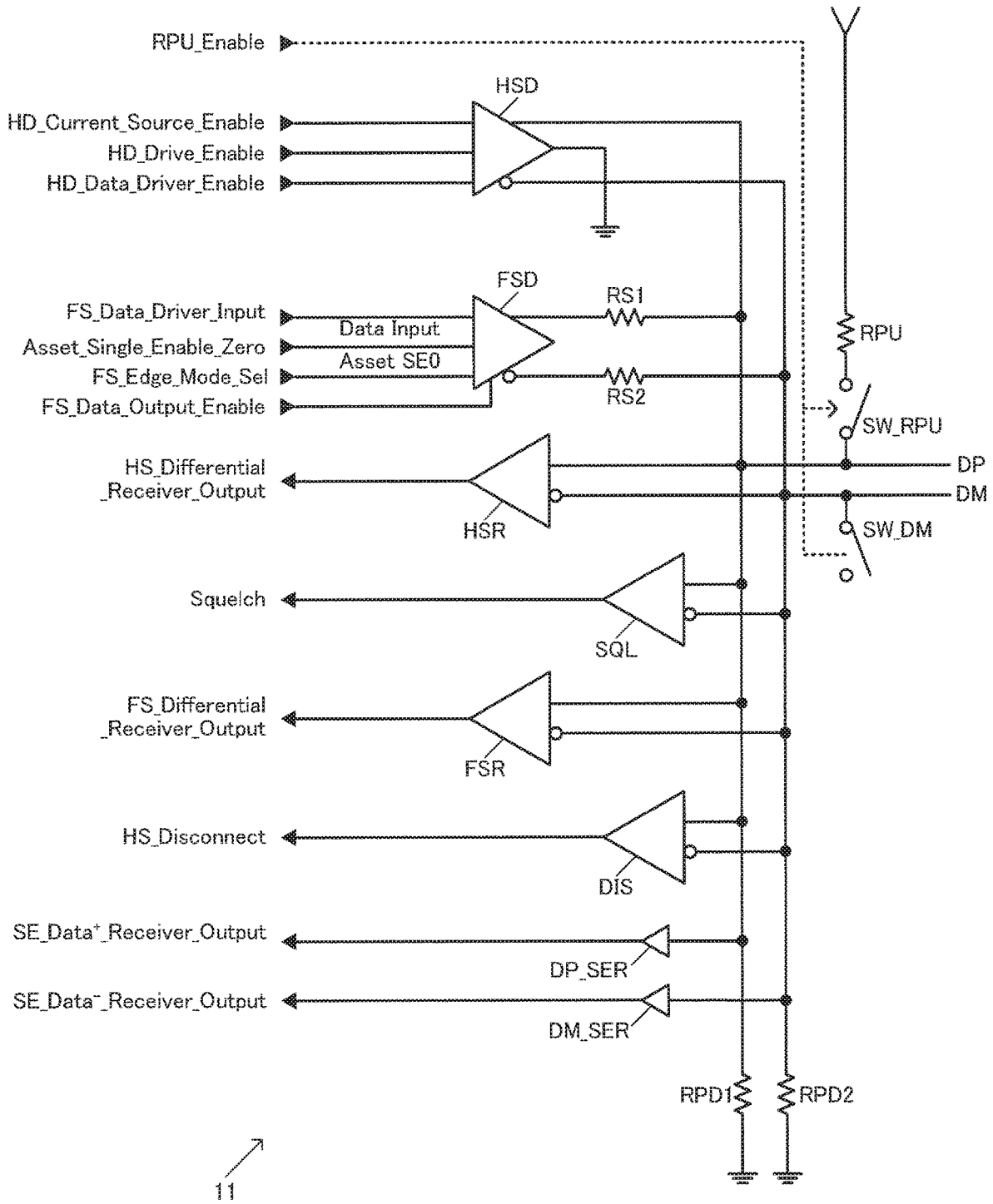

FIG. 2

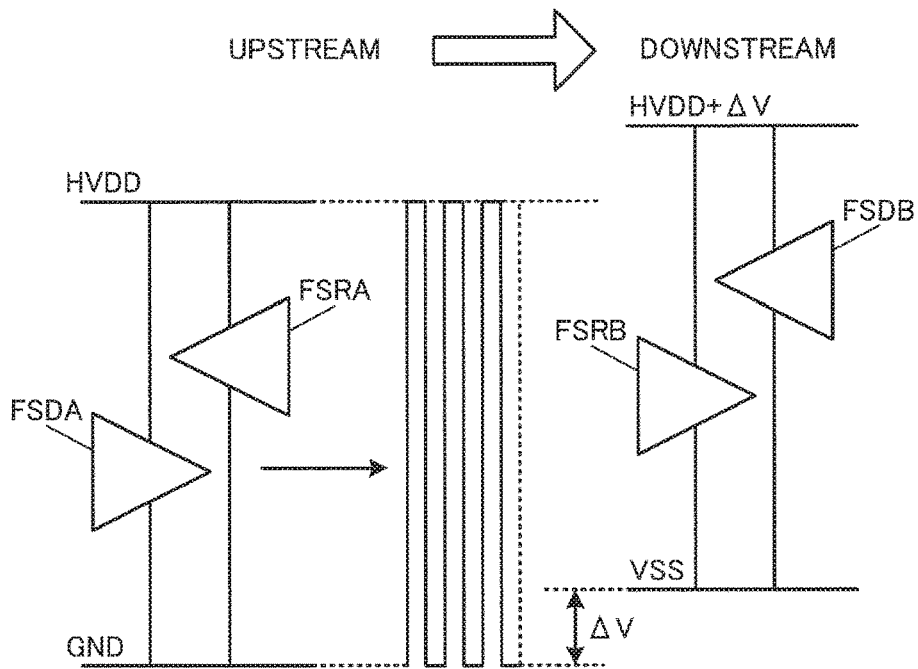

FIG. 3

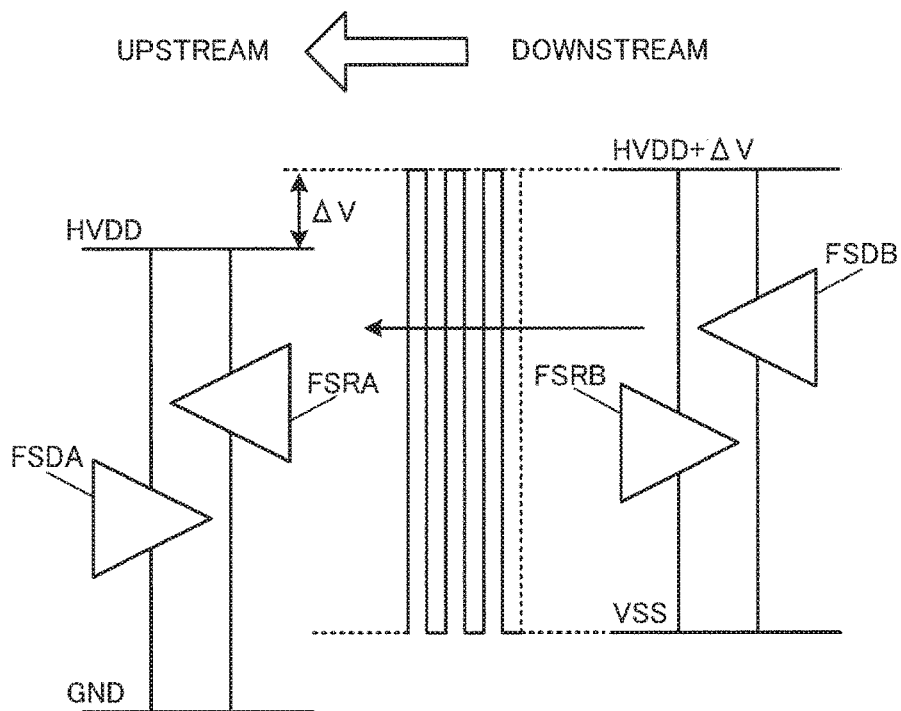

FIG. 4

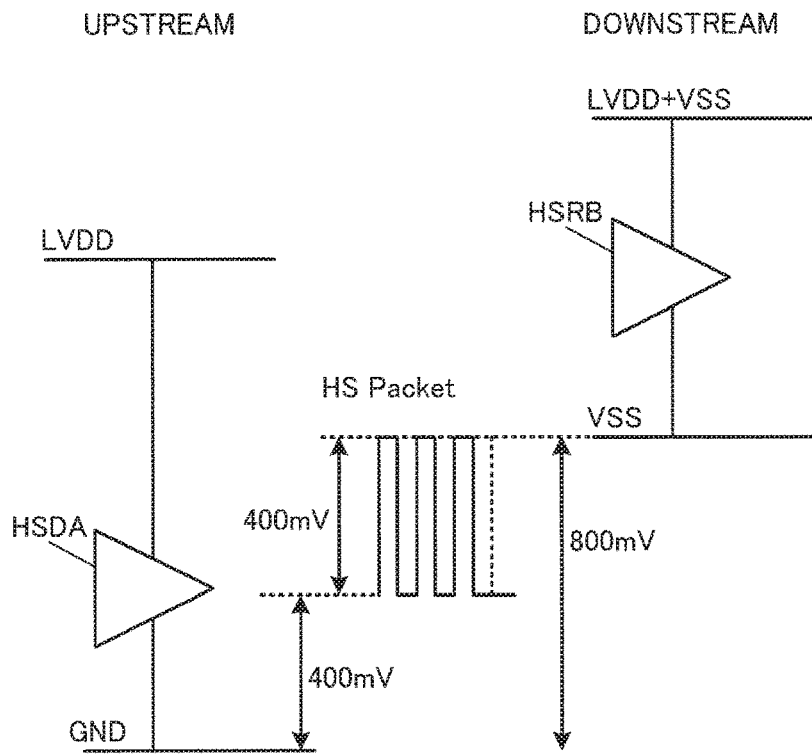

FIG. 5

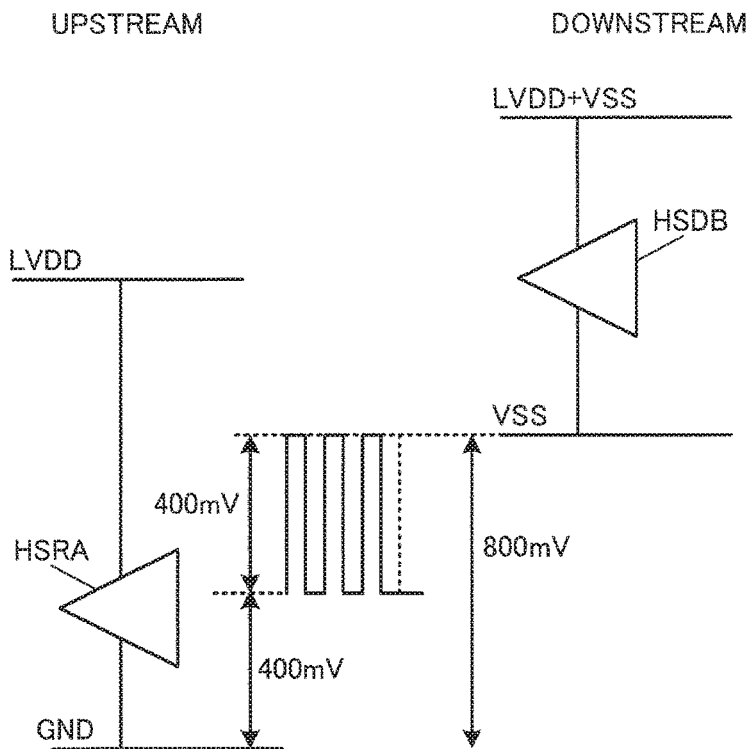

FIG. 6

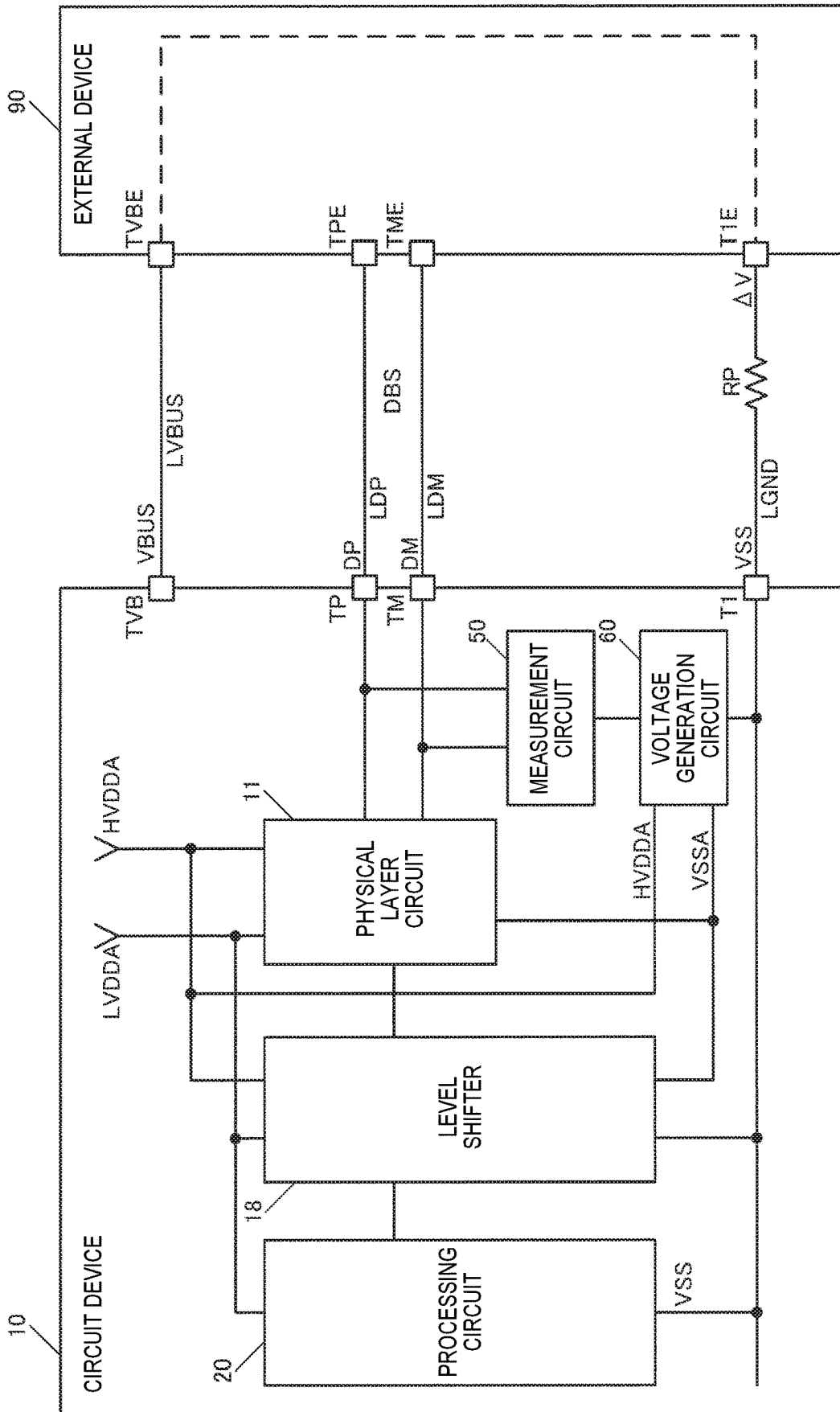

FIG. 7

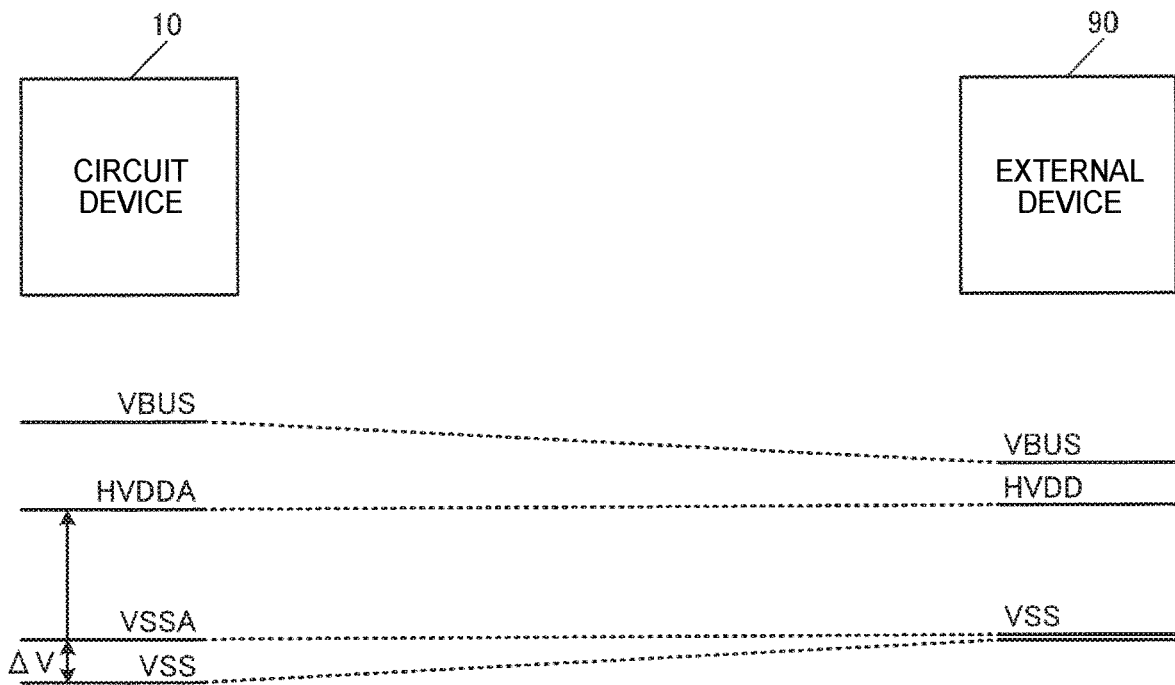

FIG. 8

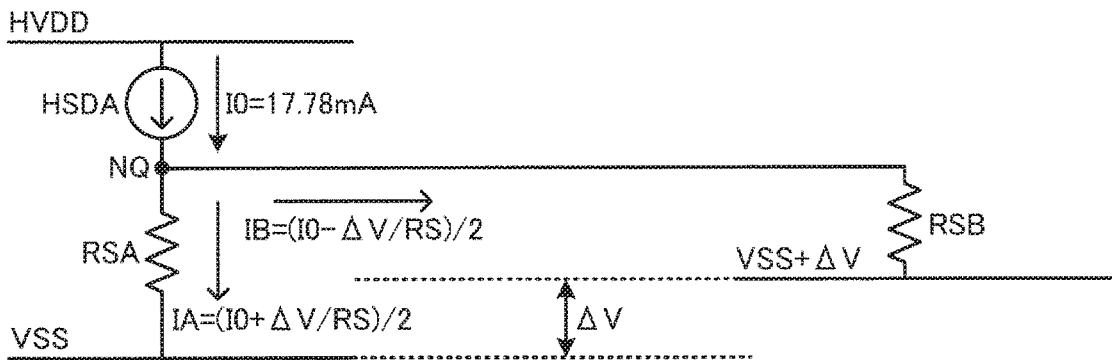

FIG. 9

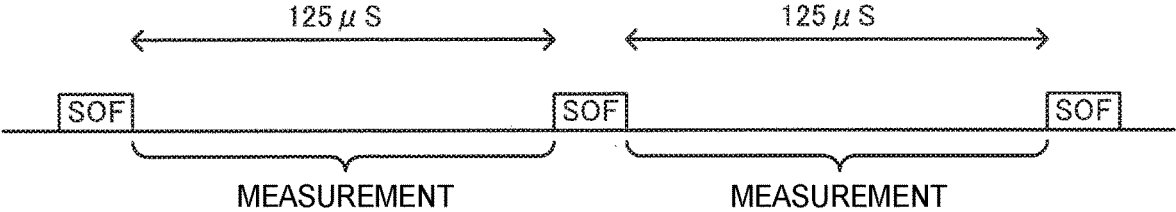

FIG. 10

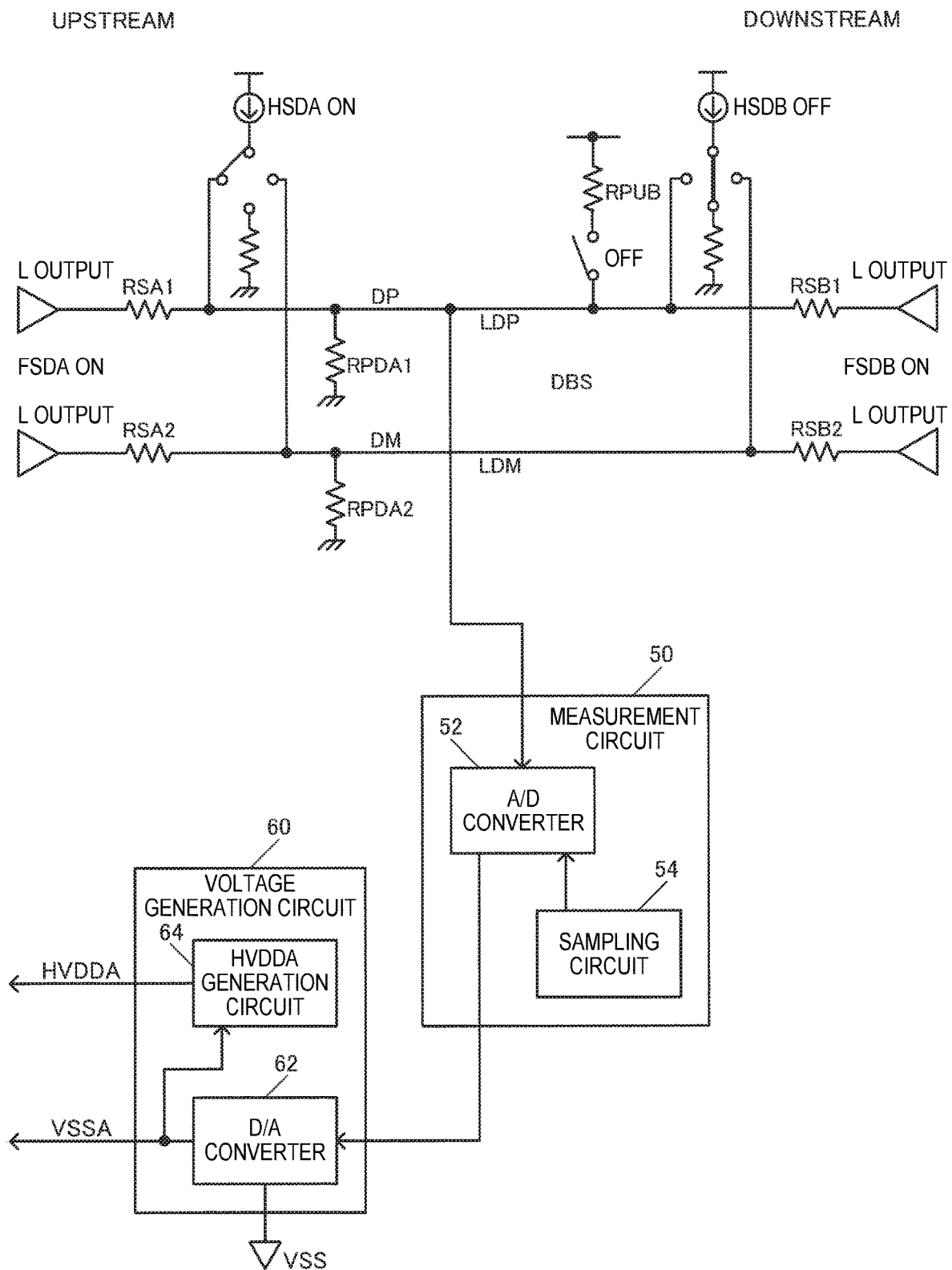

FIG. 11

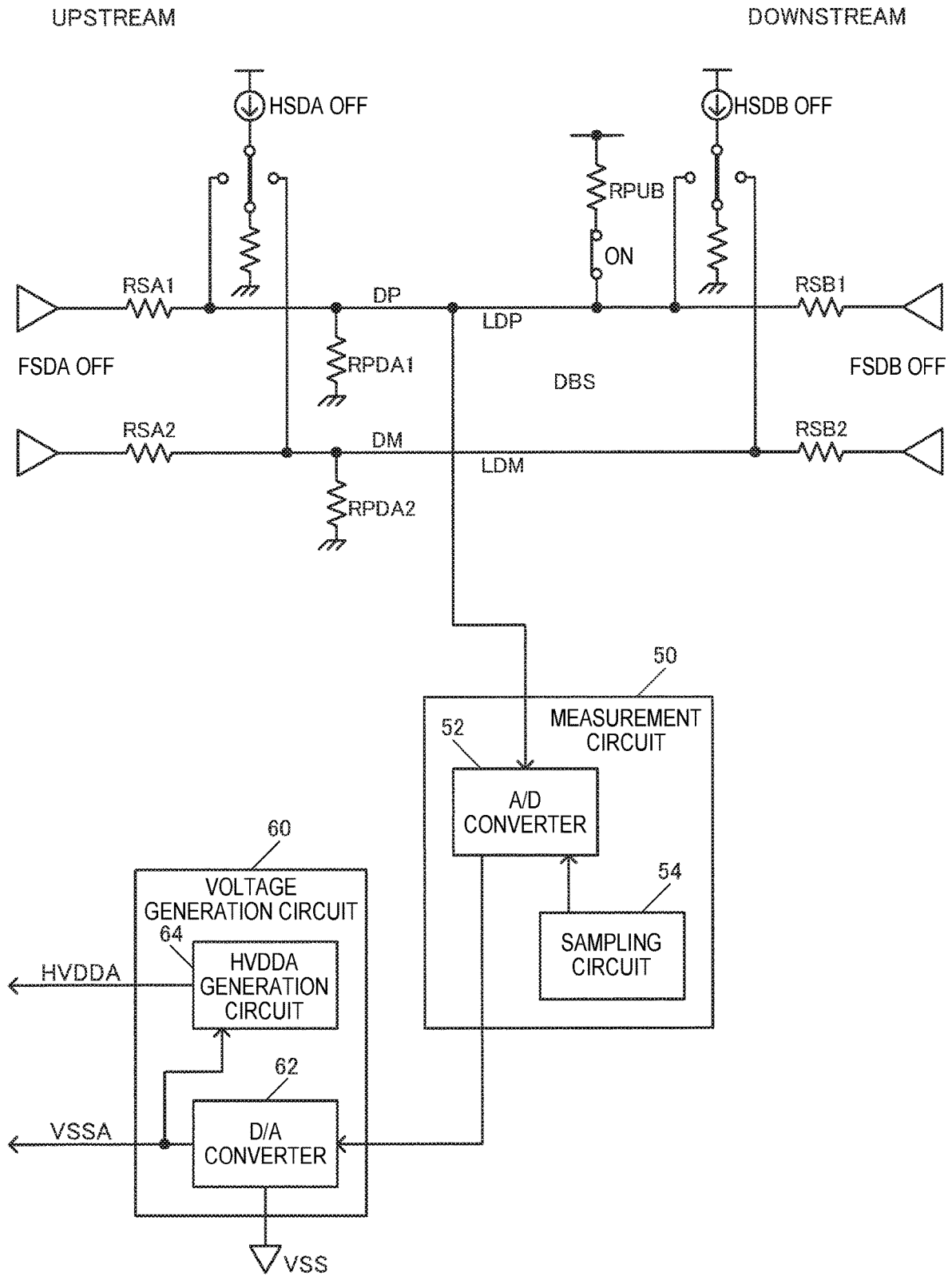

FIG. 12

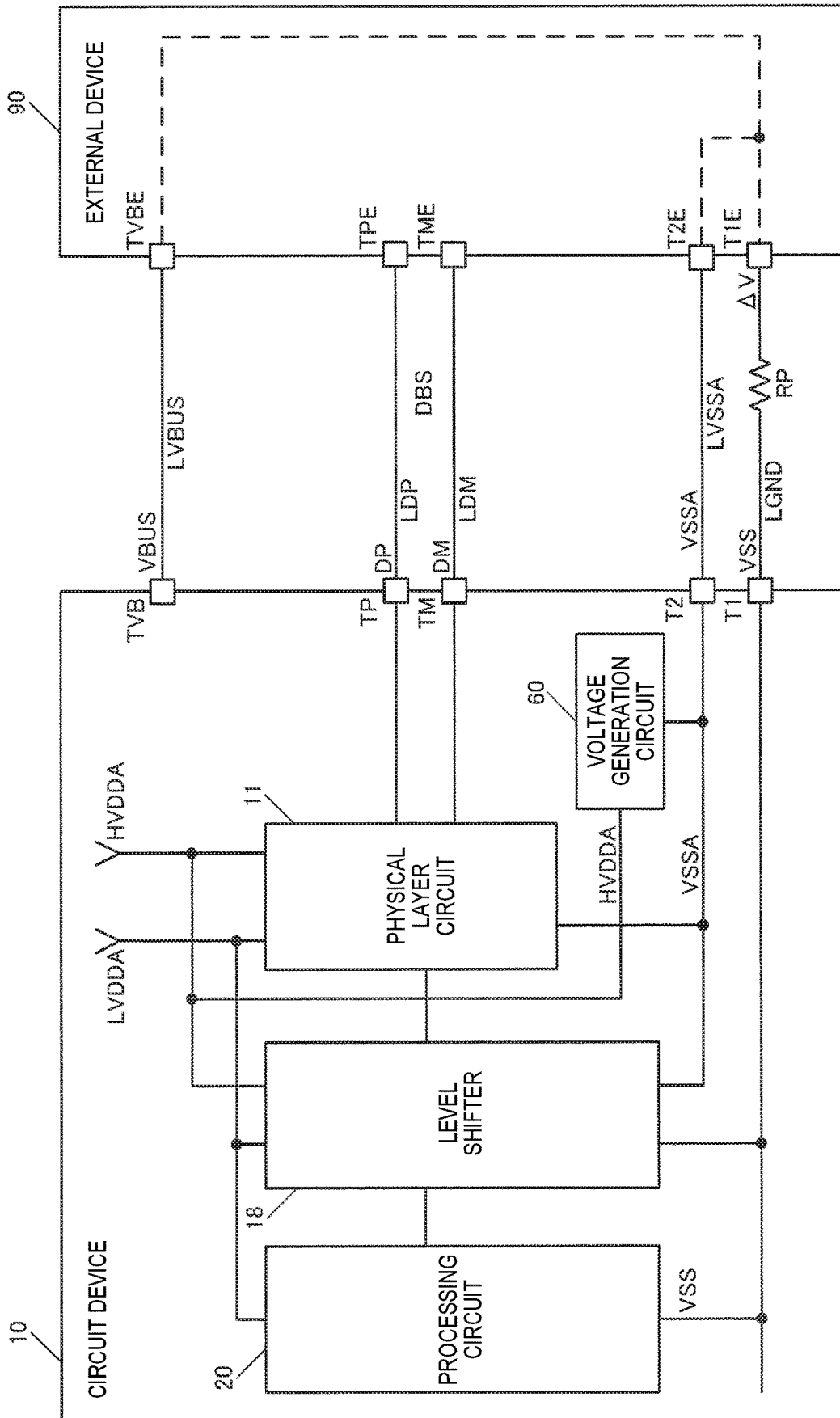

FIG. 13

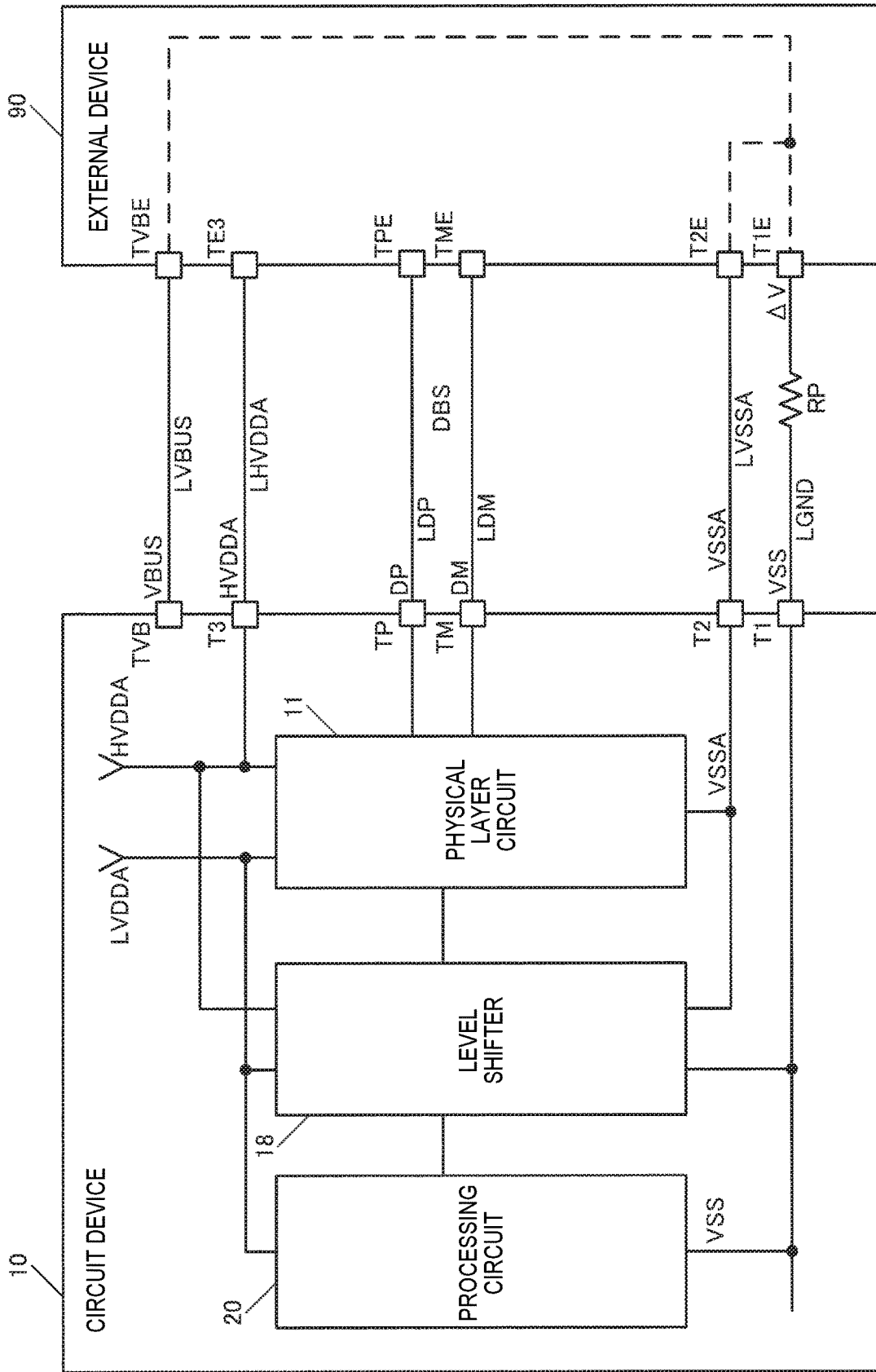

FIG. 14

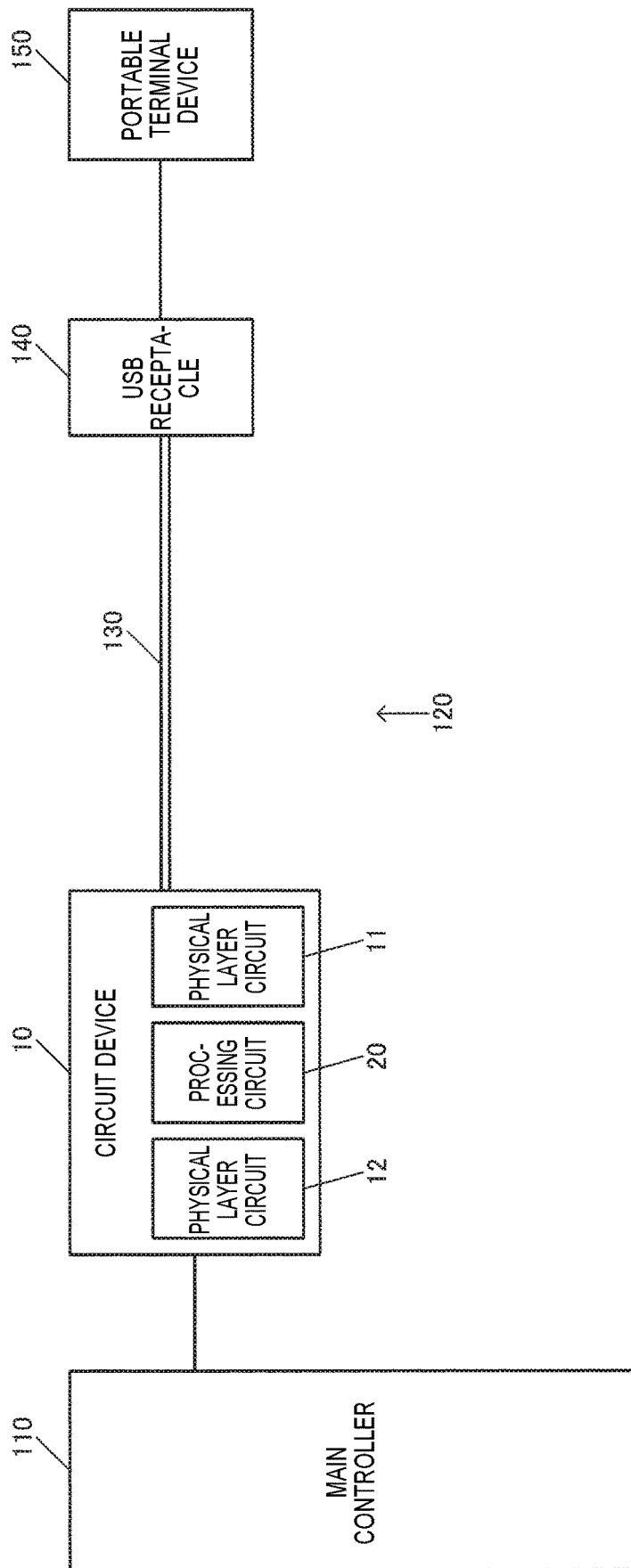

FIG. 15

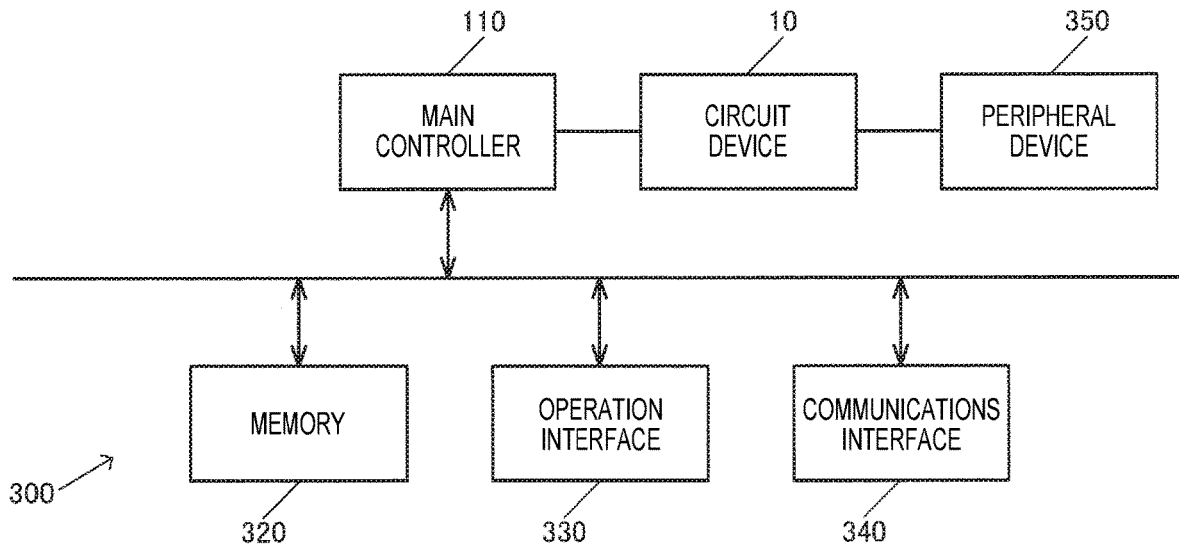

FIG. 16

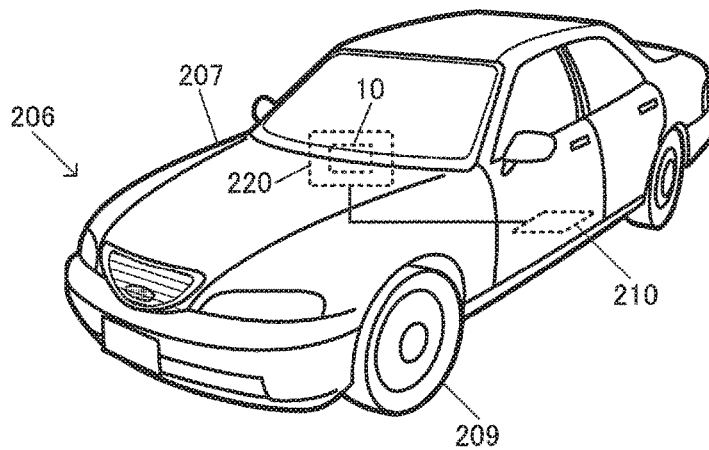

FIG. 17

CIRCUIT DEVICE, ELECTRONIC DEVICE, AND MOBILE BODY

The present application is based on, and claims priority from JP Application Serial Number 2018-114404, filed Jun. 15, 2018, the disclosure of which is hereby incorporated by reference herein in its entirety.

BACKGROUND

1. Technical Field

The present disclosure relates to a circuit device, an electronic device, and a mobile body, for example.

2. Related Art

In a circuit device that communicates using a physical layer circuit, there is a problem of a voltage drop in a cable. For example, JP-A-2014-117077 discloses a voltage drop compensation circuit capable of flexibly performing appropriate voltage compensation control according to a change in the resistance value of a vehicle USB cable. In this voltage drop compensation circuit, when power is supplied from a host through the USB cable, a switch is switched to couple the USB cable to a resistor, and the resistance value of the USB cable is detected. After a predetermined period of time, the switch is switched to couple the USB cable to a portable device, and a voltage drop compensation operation is performed based on the detected resistance value.

SUMMARY

However, the voltage drop compensation circuit of JP-A-2014-117077 focuses only on the problem of a VBUS voltage drop, and does not address the occurrence of problems such as a voltage drop in a ground line or a communications error due to a voltage drop in the ground line.

One aspect of the disclosure relates to a circuit device that includes a physical layer circuit coupled to a data bus; and a processing circuit that controls the physical layer circuit and performs communications processing through the data bus. The processing circuit operates with a voltage of a ground line as a power supply voltage on a low potential side, and the physical layer circuit operates based on a first power supply voltage on the low potential side supplied from a first power supply line not coupled to the ground line in the circuit device, and a second power supply voltage on a high potential side set with reference to the first power supply voltage.

Also, in one aspect of the disclosure, the circuit device may include a level shifter that shifts the signal level of a signal from the processing circuit to the physical layer circuit and the signal level of a signal from the physical layer circuit to the processing circuit.

Also, in one aspect of the disclosure, the circuit device may include a measurement circuit that measures the voltage of the data bus, and a voltage generation circuit that generates the first power supply voltage based on a measurement result of the measurement circuit, and generates the second power supply voltage with reference to the generated first power supply voltage.

Also, in one aspect of the disclosure, a configuration may be adopted in which the physical layer circuit includes an HS driver serving as a USB HS mode transmission circuit, the data bus includes a DP signal line that transmits a USB signal DP and a DM signal line that transmits a USB signal

DM, and the measurement circuit measures the voltage of at least one of the DP signal line and the DM signal line of the data bus coupled to the HS driver.

Also, in one aspect of the disclosure, the measurement circuit may measure the voltage of the DP signal line or the DM signal line in a period when a USB packet is not being communicated.

Also, in one aspect of the disclosure, a configuration may be adopted in which the circuit device includes a first terminal coupled to the ground line, and a second terminal coupled to the first power supply line that supplies the first power supply voltage, and the physical layer circuit operates based on the first power supply voltage supplied from outside of the circuit device to the second terminal through the first power supply line.

Also, in one aspect of the disclosure, the circuit device may include a voltage generation circuit that generates the second power supply voltage with reference to the first power supply voltage supplied to the second terminal.

Also, in one aspect of the disclosure, a configuration may be adopted in which the circuit device includes a third terminal coupled to a second power supply line that supplies the second power supply voltage, and the physical layer circuit operates based on the second power supply voltage supplied from outside of the circuit device to the third terminal through the second power supply line.

Also, another aspect of the disclosure relates to an electronic device including the above-described circuit device.

Also, another aspect of the disclosure relates to a mobile body including the above-described circuit device.

BRIEF DESCRIPTION OF THE DRAWINGS

FIG. 1 shows a configuration example of a circuit device of the present embodiment.

FIG. 2 shows a configuration example of a physical layer circuit.

FIG. 3 is an explanatory diagram of a problem regarding a GND shift in an FS mode.

FIG. 4 is an explanatory diagram of the problem regarding the GND shift in the FS mode.

FIG. 5 is an explanatory diagram of a problem regarding the GND shift in an HS mode.

FIG. 6 is an explanatory diagram of the problem regarding the GND shift in the HS mode.

FIG. 7 shows a detailed first configuration example of the circuit device of the present embodiment.

FIG. 8 illustrates operation of the present embodiment.

FIG. 9 illustrates a measurement technique of a measurement circuit.

FIG. 10 illustrates measurement timing of the measurement circuit.

FIG. 11 shows a detailed configuration example of the measurement circuit and a voltage generation circuit.

FIG. 12 shows a detailed configuration example of the measurement circuit and the voltage generation circuit.

FIG. 13 shows a detailed second configuration example of the circuit device of the present embodiment.

FIG. 14 shows a detailed third configuration example of the circuit device of the present embodiment.

FIG. 15 shows an example of application of the circuit device of the present embodiment to an in-vehicle device.

FIG. 16 shows a configuration example of an electronic device.

FIG. 17 shows a configuration example of a mobile body.

DESCRIPTION OF EXEMPLARY EMBODIMENTS

The following describes exemplary embodiments of the disclosure. Note that the embodiments described below do not unreasonably limit the scope of the disclosure described in the claims, and not all of the configurations described in these embodiments are necessary to solve problems addressed by the disclosure.

1. Circuit Device

FIG. 1 shows a configuration example of a circuit device 10 of the present embodiment. A circuit device 10 includes a physical layer circuit 11 and a processing circuit 20. The circuit device 10 can also include a level shifter 18. The physical layer circuit 11 is coupled to a data bus DBS. The data bus DBS includes a signal line LDP that is a signal line of a signal DP (DataPlus), and a signal line LDM that is a signal line of a signal DM (Data Minus). The signal line LDP is a DP signal line, and the signal line LDM is a DM signal line. The signals DP and DM are a first signal and a second signal constituting a differential signal. Terminals TP and TM of the circuit device 10 are coupled to terminals TPE and TME of an external device 90 through the signal lines LDP and LDM of the data bus DBS. Note that the coupling between circuits and the coupling between a bus or a signal line and a circuit in this embodiment are electrical couplings. An electrical coupling means coupling such that an electrical signal can be transmitted, and is a coupling that enables transmission of information by an electrical signal, and may be a coupling through a signal line or an active element or the like.

The physical layer circuit 11 is a circuit block configured with an analog circuit of a physical layer. The analog circuit of the physical layer is, for example, a transmission circuit that transmits data through the data bus DBS, a receiving circuit that receives data through the data bus DBS, or the like. Alternatively, the analog circuit of the physical layer may be various detection circuits, a pull up resistor circuit, a pull down resistor circuit, or the like.

The processing circuit 20 controls the physical layer circuit 11 to perform communications processing through the data bus DBS. For example, the processing circuit 20 outputs various control signals to the physical layer circuit 11, and performs packet transmission processing and packet receiving processing through the data bus DBS. Also, the processing circuit 20 can include a serial/parallel conversion circuit that converts serial data received through the data bus DBS into parallel data, a parallel/serial conversion circuit that converts parallel data into serial data, various link layer circuits, and the like. The processing circuit 20 can be realized by a logic circuit or the like employing automatic placement and routing, such as a gate array, for example. The processing circuit 20 may also be realized, for example, by a processor such as an MPU (Micro Processing Unit), a CPU (Central Processing Unit), or the like.

In the present embodiment, the processing circuit 20 operates with voltage supplied from a ground line LGND as a power supply voltage VSS on a low potential side. More specifically, the processing circuit 20 is operated by being supplied with the power supply voltage VSS on the low potential side and a power supply voltage LVDDA on a high potential side. The power supply voltage LVDDA is a voltage lower than a power supply voltage HVDDA, and for example, is a voltage for a logic circuit. The power supply voltage LVDDA may be supplied to the physical layer

circuit 11. For example, a terminal T1 serving as a first terminal of the circuit device 10, and a terminal T1E of the external device 90, are coupled by the ground line LGND. The processing circuit 20 is operated by the power supply voltage VSS supplied from the ground line LGND.

On the other hand, the physical layer circuit 11 operates based on a power supply voltage VSSA on the low potential side supplied from a power supply line LVSSA not coupled to the ground line LGND in the circuit device 10. Also, the physical layer circuit 11 operates based on the power supply voltage HVDDA on the high potential side set with reference to the power supply voltage VSSA. The power supply line LVSSA is a first power supply line, the power supply voltage VSSA is a first power supply voltage, and the power supply voltage HVDDA is a second power supply voltage. For example, the power supply voltage HVDDA is generated with reference to the power supply voltage VSSA. That is, in the present embodiment, in the circuit device 10, the power supply line LVSSA, which is physically separated from the ground line LGND, is provided as an internal wire. For example, the ground line LGND and the power supply line LVSSA are not coupled by metal wiring within the circuit device 10, but are set to different potentials from each other. The processing circuit 20 is operated by the power supply voltage VSS from the ground line LGND, but the physical layer circuit 11 is operated not by the power supply voltage VSS, but by using the power supply voltage VSSA as the power supply voltage on the low potential side. The power supply voltage HVDDA set with reference to the power supply voltage VSSA is also used as the power supply voltage on the high potential side that operates the physical layer circuit 11. By adopting this sort of configuration, it is possible to properly operate the circuit device 10 even when a GND shift, described later with reference to FIGS. 3 to 6, occurs, and thus it is possible to prevent occurrence of a problem such as a communications error caused by the GND shift.

For example, in the present embodiment, the circuit device 10 on an upstream side supplies a voltage VBUS to the external device 90 on a downstream side. For example, a terminal TVB of the circuit device 10 and a terminal TVBE of the external device 90 are coupled by a power supply line LVBUS, and the voltage VBUS is supplied to the external device 90 through the power supply line LVBUS. Note that the voltage VBUS may be supplied by a charging circuit provided separately from the circuit device 10, instead of by the circuit device 10. As such a charging circuit, there is a circuit conforming to the specifications of USB BC 1.2 (Battery Charging Specification Rev 1.2), for example.

The external device 90 operates by being supplied with the voltage VBUS. For example, each circuit block of the external device 90 operates with a power supply voltage based on the voltage VBUS. For example, similarly to the circuit device 10, the external device 90 has a physical layer circuit and a processing circuit, and the physical layer circuit and the processing circuit operate with a power supply voltage based on the voltage VBUS. Alternatively, the external device 90 performs charging of a secondary battery or the like using the voltage VBUS. Therefore, much current flows to the power supply line LVBUS in a current path indicated by A1 in FIG. 1. Then, this current returns to the circuit device 10 side through the ground line LGND as indicated by A2. A parasitic resistance RP exists in the ground line LGND, so the current flows against the parasitic resistance RP as indicated by A2, and therefore the GND shift problem occurs. That is, the ground line LGND is grounded to nearly 0 V in the vicinity of the terminal T1 of

the circuit device **10**, but in the vicinity of the terminal **T1E** of the external device **90**, the ground line **LGND** is shifted from 0 V, which is the GND potential, by ΔV due to the current flowing in the parasitic resistance **RP**. When this sort of GND shift occurs, as will be described in detail later with

reference to FIGS. **3** to **6**, problems occur such as a communications error in data communications through the data bus **DBS**, or exceeding a maximum rating of the external device **90**.
 In this regard, in the present embodiment, the physical layer circuit **11** operates based on the power supply voltage **VSSA** from the power supply line **LVSSA** that is not coupled to the ground line **LGND** in the circuit device **10**. Also, the physical layer circuit **11** operates based on the power supply voltage **HVDDA** on the high potential side with reference to the power supply voltage **VSSA**. That is, as a power supply system of the physical layer circuit **11**, the power supply system of the voltages **VSSA** to **HVDDA** is separately and independently provided. By operating the physical layer circuit **11** based on the power supply voltage **VSSA** from the power supply line **LVSSA** separated from the ground line **LGND**, it is possible to prevent the GND shift from influencing the physical layer circuit **11**, and it is possible to prevent the occurrence of problems caused by the GND shift. Note that it is sufficient that the ground line **LGND** is not coupled to the power supply line **LVSSA** in the internal wiring within the circuit device **10**, and these may be electrically coupled to each other in the external device **90**, for example.

The circuit device **10** includes the level shifter **18** provided between the physical layer circuit **11** and the processing circuit **20**. For example, the level shifter **18** is provided between the physical layer circuit **11** and the processing circuit **20** by electrical coupling. For example, the physical layer circuit **11** and the level shifter **18** are electrically coupled through a signal line, and the level shifter **18** and the processing circuit **20** are electrically coupled through a signal line. The level shifter **18** shifts the signal level of the signal from the processing circuit **20** to the physical layer circuit **11**, and the signal level of the signal from the physical layer circuit **11** to the processing circuit **20**. For example, the level shifter **18** is supplied with the power supply voltages **HVDDA** and **LVDDA** on the high potential side and the power supply voltages **VSSA** and **VSS** on the low potential side to perform level shifting of the signal level. For example, the level shifter **18** shifts the level of a signal in the voltage range from the voltage **VSSA** to the voltage **HVDDA** to a signal in the voltage range from the voltage **VSS** to the voltage **LVDDA**. Alternatively, the level shifter **18** shifts the level of a signal in the voltage range from the voltage **VSS** to the voltage **LVDDA** to a signal in the voltage range from the voltage **VSSA** to the voltage **HVDDA**. The signal to be level-shifted by the level shifter **18** is a data signal communicated through the data bus **DBS**, a control signal of the physical layer circuit **11**, or the like. When such a level shifter **18** is provided, even when the physical layer circuit **11** is operated by the power supply voltages **HVDDA** and **VSSA**, a signal from the processing circuit **20** can be transmitted to the physical layer circuit **11** at an appropriate signal level, and a signal from the physical layer circuit **11** can be transmitted to the processing circuit **20** at an appropriate signal level. That is, it is possible to absorb a shift in ΔV due to the GND shift by the level shifter **18**, and thus it is possible to provide stable communications.

FIG. **2** shows a configuration example of the physical layer circuit **11**. Note that in the following description, mainly a case where the technique of the present embodi-

ment is applied to USB will be described. In this case, the data bus **DBS**, the power supply line **LVBUS**, and the ground line **LGND** in FIG. **1** are lines provided in a USB cable. Note that the technique of the present embodiment is also applicable to standards that have evolved from the USB standard, standards based on the same idea as USB, and standards other than USB.

The physical layer circuit **11** includes a pull up resistor **RPU**, switch elements **SW_RPU** and **SW_DM**, and pull down resistors **RPD1** and **RPD2**. The switch element **SW_RPU** is switched on or off based on a control signal **RPU_Enable**. Thus a pull up operation is realized. The physical layer circuit **11** includes an HS driver **HSD** that is a transmission circuit for HS (High Speed), an FS driver **FSD** that is a transmission circuit for FS (Full Speed), and resistors **RS1** and **RS2**. The HS driver **HSD** is a current driver that performs current driving, and the FS driver **FSD** is a voltage driver that performs voltage driving. Note that the FS driver **FSD** is also used for LS (Low Speed), and is a driver used for both FS and LS. At the time of HS termination, the FS driver **FSD** outputs an L level signal such that the resistors **RS1** and **RS2** function as terminating resistors of 45Ω. When the HS termination is disabled, the output of the FS driver **FSD** is in a high impedance state.

Also, the physical layer circuit **11** includes an HS receiver **HSR** that is a differential receiving circuit for HS, a transmission envelope detector **SQL** that is a squelch detection circuit, an FS receiver **FSR** that is a differential receiving circuit for FS, a decoupling envelope detector **DIS** that is a decoupling detection circuit, and single end receivers **DP_SER** and **DM_SER** that are single end receiving circuits. Note that the FS receiver **FSR** is also used for LS, and is a receiver used for both FS and LS. The level shifter **18** performs level shifting of various control signals and data signals shown in FIG. **2**.

Note that when the physical layer circuit **11** is a circuit conforming to USB, the processing circuit **20** includes a serial/parallel conversion circuit that converts serial data received through USB into parallel data, a parallel/conversion circuit that converts parallel data into serial data, and a circuit corresponding to a link layer of an elastic buffer, an NRZI circuit, or the like. For example, a circuit corresponding to a link layer or the like among USB transceiver macrocells is included in the processing circuit **20**, and analog circuits such as a transmission circuit, a receiving circuit, and a detection circuit are included in the physical layer circuit **11**.

Next, the problem of the GND shift will be described in detail with reference to FIGS. **3** to **6**. FIGS. **3** and **4** illustrate the problem of the GND shift in the FS mode. In FIG. **3**, an FS driver **FSDA** on the upstream side transmits a signal, and an FS receiver **FSRB** on the downstream side receives the signal. In FIG. **4**, an FS driver **FSDB** on the downstream side transmits a signal, and an FS receiver **FSRA** on the upstream side receives the signal. The upstream side is the circuit device **10** of FIG. **1**, and for example, is a USB host. The downstream side is the external device **90** of FIG. **1**, and for example, is a USB device. On the upstream side, the potential of the ground line **LGND** becomes 0 V, which is the GND level. On the other hand, when the current indicated by **A2** flows through the parasitic resistance **RP** in FIG. **1**, on the downstream side, the GND shift, in which the potential of the ground line **LGND** rises from 0 V by ΔV , occurs. When this sort of GND shift occurs, the receiving sensitivity of the FS receiver **FSRB** decreases. When the voltage range of the transmission signal of the FS driver **FSDA** greatly shifts from the receivable voltage range of the

FS receiver FSRB, a situation occurs in which the FS receiver FSRB cannot properly receive the transmission signal. Also, a problem that the maximum rating of the power supply voltage of the external device 90 is exceeded occurs due to generation of the GND shift of ΔV . For example, when ΔV becomes about 0.4 V, a diode of a PN junction in the external device 90 switches on and current flows, and when ΔV exceeds, for example, 0.6 V, a large current flows and a situation occurs in which a guaranteed range is exceeded. A similar problem also occurs when the FS driver FSDB on the upstream side transmits a signal to the FS receiver FSRA on the downstream side as shown in FIG. 4.

FIGS. 5 and 6 illustrate the problem of the GND shift in the HS mode. In FIG. 5, an HS driver HSDA on the upstream side transmits a signal, and an HS receiver HSRB on the downstream side receives the signal. In FIG. 6, an HS driver HSDB on the downstream side transmits a signal, and an HS receiver HSRA on the upstream side receives a signal. In this case, when the GND shift occurs, the receiving sensitivity of the HS receiver HSRA greatly decreases, and as a result, problems occur such as a communications error in which a signal cannot be properly received, or a maximum rating is exceeded. For example, in FIG. 5, the HS driver HSDA, with reference to a voltage of 400 mV from the GND, transmits an HS packet signal having a signal amplitude of 400 mV. In FIG. 5, the GND shift of $\Delta V=800$ mV occurs, so the voltage range of the HS packet signal from the HS driver HSDA does not fall within the receivable voltage range of the HS receiver HSRB. Therefore, the HS receiver HSRB cannot properly receive the HS packet signal, and a communications error occurs.

Particularly with USB, the power supply power of the voltage VBUS at the time of charging a battery rises, and in the specifications of BC 1.2, it is possible to charge with a large current such as 1.5 A, for example. Therefore, when such a large current flows at the voltage VBUS, the ΔV in the GND shift increases. Further, in an in-vehicle device or the like, the cable 130 in FIG. 15 described later becomes long, so the parasitic resistance RP in FIG. 1 becomes large, and ΔV also increases with this. When ΔV increases, as described in FIGS. 3 to 6, problems such as a communications error or exceeding a maximum rating occur.

In this regard, in the present embodiment, the physical layer circuit 11 operates by the power supply system of the voltages VSSA to HVDDA independent of the power supply system by the ground line LGND. For example, a large current such as a charging current does not flow through the USB cable to the power supply line LVSSA, and only the current consumption in the physical layer circuit 11 flows. Therefore, it is possible to effectively prevent the occurrence of problems caused by the GND shift as described with reference to FIGS. 3 to 6.

2. Detailed Configuration Example

FIG. 7 shows a detailed first configuration example of the circuit device 10 of the present embodiment. In FIG. 7, the circuit device 10 includes a measurement circuit 50 and a voltage generation circuit 60. The measurement circuit 50 measures the voltage of the data bus DBS. For example, the voltage of the signal line LDP serving as the DP signal line, or the voltage of the signal line LDM serving as the DM signal line, is measured. Note that the voltages of both the signal line LDP and the signal line LDM may be measured. In this case, for example, an average value of the two measured voltages may be used as the measurement voltage serving as the measurement result. In this way, the measurement circuit 50 measures the voltage of at least one of the

signal line LDP and the signal line LDM. Note that the DP signal line is a signal line that transmits a USB DP signal, and the DM signal line is a signal line that transmits a USB DM signal.

The voltage generation circuit 60 generates the power supply voltage VSSA serving as the first power supply voltage based on the measurement result of the measurement circuit 50. The voltage generation circuit 60 generates the power supply voltage HVDDA serving as the second power supply voltage with reference to the generated power supply voltage VSSA. The physical layer circuit 11 operates by being supplied with the power supply voltages VSSA and HVDDA, and performs signal transmission and signal receiving in the HS mode, the FS mode, or the LS mode.

FIG. 8 illustrates operation of the present embodiment. On the external device 90 side, the GND shift of ΔV occurs. In this case, the circuit device 10 generates, as the power supply voltage VSSA, a voltage that is shifted by ΔV from the power supply voltage VSS of the ground line LGND. Specifically, ΔV is measured by the measurement circuit 50 measuring the voltage of the data bus DBS. The voltage generation circuit 60 generates the power supply voltage VSSA based on the measured ΔV . For example, the power supply voltage VSSA is generated such that $VSSA=VSS+\Delta V$. Also, the voltage generation circuit 60 generates the power supply voltage HVDDA based on the power supply voltage VSSA. For example, as shown in FIG. 8, the power supply voltage HVDDA is generated with reference to the power supply voltage VSSA such that a relationship $HVDDA=VSSA+(HVDD-VSS)$ is established. That is, a voltage of $(HVDD \times VSS)$ is added in an analog manner to the power supply voltage VSSA to generate the power supply voltage HVDDA. For example, $HVDD-VSS$ is a power supply voltage range in the physical layer circuit of the external device 90, and is, for example, a voltage range of 3.3 V. In the present embodiment, a configuration is adopted such that a relationship $HVDDA-VSSA=HVDD-VSS$ is established.

By adopting this sort of configuration, by measuring the voltage of the data bus DBS, it is possible to generate the power supply voltages VSSA and HVDDA by measuring ΔV , which is the shift voltage generated by the GND shift. By operating the physical layer circuit 11 based on the generated power supply voltages VSSA and HVDDA, it is possible to prevent the occurrence of problems due to the GND shift described in FIGS. 3 to 6.

FIG. 9 illustrates the measurement technique of the measurement circuit 50 in the HS mode. For example, in the present embodiment, the physical layer circuit 11 of the circuit device 10 includes the HS driver HSDA serving as a USB HS mode transmission circuit. The measurement circuit 50 measures the voltage of the signal line LDP or the signal line LDM of the data bus DBS coupled to the HS driver HSDA.

The HS driver HSDA uses a current source to flow a current of $I0=17.78$ mA. This current flows through a resistor RSA that is a terminating resistor on the circuit device 10 side and a resistor RSB that is a terminating resistor on the external device 90 side. Here it is assumed that the resistance values of the resistors RSA and RSB are $RS=45\Omega$, and a voltage shift of ΔV occurs due to the GND shift. In this case, the current that flows through the resistor RSA is $IA=(I0+\Delta V/RS)/2$, and the current that flows through the resistor RSB is $IB=(I0-\Delta V/RS)/2$.

When the GND shift is not occurring, a voltage VNQ of an output node NQ of the signals DP and DM, which is a coupling node between the HS driver HSDA and the resis-

tors RSA and RSB, becomes $V_{NQ}=17.78 \text{ mA} \times 22.5 \text{ } \Omega = 400 \text{ mV}$. On the other hand, when the GND shift occurs, the current that flows through the resistor RSA becomes $I_A = (I_0 + \Delta V / R_S) / 2$, so the voltage of the output node NQ rises from $V_{NQ}=400 \text{ mV}$ to $V_{NQ}=400 \text{ mV} + \Delta V / 2$. Therefore, $\Delta V / 2$ can be measured by measuring the voltage of the data bus DBS where the signals DP and DM are output, and ΔV that is the shift voltage due to the GND shift can be calculated. That is, by measuring the voltage of the signal line LDP or the signal line LDM in the HS mode, $\Delta V / 2$ can be measured and so ΔV can be measured. By the measurement circuit 50 measuring ΔV in this manner, as shown in FIG. 8, the voltage generation circuit 60 can generate the power supply voltage $V_{SSA} = V_{SS} + \Delta V$, and the power supply voltages V_{SSA} and HV_{DDA} can be supplied to the physical layer circuit 11.

In this case, the measurement circuit 50 measures the voltage of the signal line LDP or the signal line LDM during a period when USB packets are not being communicated. For example, as shown in FIG. 10, during an HS idle period, an SOF (Start of Frame) packet is transmitted every 125 μs and sent from the host on the upstream side to the device on the downstream side. Therefore, in this case, as shown in FIG. 10, during a period when a SOF packet, which is a USB packets, is not being communicated, the voltage of the signal line LDP or the signal line LDM is measured and ΔV , which is the shift voltage due to the GND shift, is measured. By adopting this sort of configuration, ΔV can be measured by effectively using a period when a USB packet is not being communicated, and it is possible to prevent a situation in which the measurement by the measurement circuit 50 affects USB packet communications.

FIG. 11 shows a detailed configuration example of the measurement circuit 50 and the voltage generation circuit 60. FIG. 11 shows an example of measurement in the HS mode, specifically, an example of measurement during an HS idle period. The FS driver FSDA on the upstream side outputs an L level signal, whereby resistors RSA1 and RSA2 function as terminating resistors. Likewise, the FS driver FSDB on the downstream side also outputs an L level signal, whereby resistors RSB1 and RSB2 function as terminating resistors. Note that pull up operation by a pull up resistor RPUB is off. On/off switching of pull up operation by the pull up resistor RPUB can be realized by, for example, switching on and off a switch that couples one end of the pull up resistor RPUB to the signal line LDP. The same is true for on/off switching of pull down operation by a pull down resistor. Also, the HS driver HSDA on the upstream side is on, current from the current source of the HS driver HSDA flows to the resistor RSA1 on the upstream side and the resistor RSB1 on the downstream side, and thus measurement of ΔV as described above is possible.

The measurement circuit 50 includes an A/D converter 52 and a sampling circuit 54. The A/D converter 52, for example, performs A/D conversion of the voltage of the signal line LDP, and outputs digital data corresponding to ΔV for example. Note that FIG. 11 shows an example where the measurement circuit 50 measures the voltage of the signal line LDP, but the measurement circuit 50 may measure the voltage of the signal line LDM. In this case, the A/D converter 52 performs A/D conversion of the voltage of the signal line LDM. Alternatively, the measurement circuit 50 may perform A/D conversion of the voltages of both the signal line LDP and the signal line LDM to measure the voltage. In this case, an average value of the digital data of the measured voltages may be used as the measurement result.

The sampling circuit 54 controls sampling operation of the signal of the A/D converter 52. Specifically, the sampling circuit 54 outputs a sampling clock signal to the A/D converter 52 to control the sampling operation. For example, the sampling circuit 54 controls the A/D converter 52 so as to perform A/D conversion by sampling the signal of the signal line LDP in a period when HS packets are not being communicated. By adopting this sort of configuration, as described in FIG. 10, the voltage of the signal line LDP or the like in a period when HS packets are not being communicated can be measured by the measurement circuit 50.

The voltage generation circuit 60 includes a D/A converter 62 and an HV_{DDA} generation circuit 64. The D/A converter 62 receives digital data corresponding to the ΔV of the GND shift from the A/D converter 52 of the measurement circuit 50. Then, D/A conversion of the received digital data is performed to generate and output the power supply voltage V_{SSA} satisfying $V_{SSA} = V_{SS} + \Delta V$. The HV_{DDA} generation circuit 64 generates and outputs a power supply voltage HV_{DDA} on the high potential side with reference to the power supply voltage V_{SSA} , based on the power supply voltage V_{SSA} on the low potential side from the D/A converter 62. The HV_{DDA} generation circuit 64 can be realized by an operational amplifier, a resistance element, or the like that outputs the power supply voltage HV_{DDA} based on the power supply voltage V_{SSA} .

According to the measurement circuit 50 and the voltage generation circuit 60 of FIG. 11, by measuring the voltage of the data bus DBS during an HS idle period, ΔV , which is the shift voltage of the GND shift, is obtained, and thus it is possible to generate the power supply voltages V_{SSA} and HV_{DDA} having a potential relationship as shown in FIG. 8, and supply these to the physical layer circuit 11.

Note that it is also possible to measure ΔV , which is the shift voltage of the GND shift, in the FS mode or the LS mode. For example, in FIG. 12, the FS driver FSDA and the FS driver FSDB are off, and the HS driver HSDA and the HS driver HSDB are also off. Pull up operation by the pull up resistor RPUB on the downstream side is on. Specifically, switching that couples one end of the pull up resistor RPUB to the signal line LDP is on. On the upstream side, the signal line LDP is pulled down by the pull down resistor RPD1. Note that a configuration may also be adopted in which, when measuring the voltage of the signal line LDM, on the downstream side, pull up operation by the pull up resistor for the signal line LDM is switched on, and on the upstream side, the pull down operation by the pull down resistor for the signal line LDM is switched on. Switching on/off of the pull down operation by the pull down resistor can be realized, for example, by switching on/off a switch that couples one end of a pull down resistor to the signal line LDM.

For example, the other end of the pull up resistor RPUB is coupled to a power supply node of 3.3 V, the resistance value of the pull up resistor RPUB is 1.5 K Ω , and the resistance value of the pull down resistor RPD1 is 15 K Ω . Therefore, when the GND shift of ΔV has occurred, the voltage V_{LDP} of the signal line LDP is $V_{LDP} = (3.3 \text{ V} + \Delta V) \times \{15 \text{ K}\Omega / (15 \text{ K}\Omega + 1.5 \text{ K}\Omega)\}$. Therefore, by measuring the voltage V_{LDP} with the measurement circuit 50, it is possible to measure ΔV due to the GND by inverse calculation. For example, the measurement circuit 50 calculates ΔV by performing arithmetic processing on the A/D conversion result of the A/D converter 52. The voltage generation circuit 60 generates the power supply voltages V_{SSA} and HV_{DDA} based on the calculated ΔV , and supplies this to the physical layer circuit 11. The configurations of the measure-

11

ment circuit **50** and the voltage generation circuit **60** are the same as those in FIG. **11**, so a detailed description thereof will be omitted.

FIG. **13** shows a detailed second configuration example of the circuit device **10** of the present embodiment. In FIG. **13**, the circuit device **10** includes a terminal **T1** coupled to the ground line **LGND**, and a terminal **T2** coupled to the power supply line **LVSSA** that supplies the power supply voltage **VSSA**. The power supply voltage **VSSA** is a first power supply voltage, the power supply line **LVSSA** is a first power supply line, the terminal **T1** is a first terminal, and the terminal **T2** is a second terminal. The physical layer circuit **11** operates based on the power supply voltage **VSSA** supplied from outside of the circuit device **10** to the terminal **T2** through the power supply line **LVSSA**. For example, the power supply line **LVSSA** is electrically coupled to the ground line **LGND** by internal wiring of the external device **90**. For example, a terminal **T2E** of the external device **90** coupled to the power supply line **LVSSA** and a terminal **T1E** of the external device **90** coupled to the ground line **LGND** are coupled by the internal wiring of the external device **90**. Therefore, when the GND shift occurs on the external device **90** side, the power supply voltage **VSSA** at which $VSSA = VSS + \Delta V$ is transmitted to the circuit device **10** through the power supply line **LVSSA**. That is, in the external device **90**, when the potential of the ground line **LGND** increases by ΔV from 0 V due to the GND shift, this potential increase is transmitted to the power supply line **LVSSA** coupled to the ground line **LGND** by the internal wiring of the external device **90**, and is also transmitted to the circuit device **10**. Thus, as shown in FIG. **8**, the power supply voltage **VSSA** at which $VSSA = VSS + \Delta V$ is supplied as the power supply voltage on the low potential side to operate the physical layer circuit **11**. As a result, it is possible to prevent the occurrence of a problem such as a communications error due to the GND shift described with reference to FIGS. **3** to **6**.

In this way, in the second configuration example of FIG. **13**, there is an advantage that with a simple configuration of providing the terminal **T2** for the power supply line **LVSSA** for transmitting the power supply voltage $VSSA = VSS + \Delta V$ from the external device **90**, occurrence of a problem due to the GND shift can be prevented. For example, a large current such as a charging current flows through the power supply line **LVBUS** and the ground line **LGND**, and due to that large current flowing through the parasitic resistance **RP**, the ΔV due to the GND shift increases, and a problem as described in FIGS. **3** to **6** occurs. On the other hand, in the configuration shown in FIG. **13**, only the current consumption in the physical layer circuit **11** flows through the power supply line **LVSSA**, and this consumption current is much smaller than the large current such as a charging current, so the GND shift problem substantially does not occur and can be ignored.

Also, in FIG. **13**, the circuit device **10** includes the voltage generation circuit **60** that generates the power supply voltage **HVDDA** with reference to the power supply voltage **VSSA** supplied to the terminal **T2**. The voltage generation circuit **60** generates the power supply voltage **HVDDA** with a potential relationship as shown in FIG. **8**. That is, the voltage generation circuit **60** adds a voltage of $(HVDD - VSS)$ in an analog manner to the power supply voltage **VSSA**, so as to satisfy $HVDDA = VSSA + (HVDD - VSS)$, to generate the power supply voltage **HVDDA**. The voltage generation circuit **60** can be realized by, for example, an operational amplifier, a resistance element, or the like to which the power supply voltage **VSSA** is input, and that outputs the

12

power supply voltage **HVDDA**. By adopting this sort of configuration, it is possible to properly operate the physical layer circuit **11** by supplying, with reference to the power supply voltage **VSSA**, a power supply voltage in the power supply voltage range of the voltages **HVDDA** to **VSSA**, corresponding to the voltages **HVDD** to **VSS**, to the physical layer circuit **11**.

FIG. **14** shows a detailed third configuration example of the circuit device **10** of the present embodiment. In FIG. **14**, the circuit device **10** includes a terminal **T3** coupled to a power supply line **LHVDDA** that supplies the power supply voltage **HVDDA**. The power supply voltage **HVDDA** is a second power supply voltage, the power supply line **LHVDDA** is a second power supply line, and the terminal **T3** is a third terminal. The physical layer circuit **11** operates based on the power supply voltage **HVDDA** supplied from outside of the circuit device **10** to the terminal **T3** through the power supply line **LHVDDA**. For example, the power supply line **LHVDDA** couples the terminal **T3** of the circuit device **10** and a terminal **TE3** of the external device **90**. The external device **90** supplies the power supply voltage **HVDDA** to the circuit device **10** through the terminal **TE3** and the power supply line **LHVDDA**. Thus, the physical layer circuit **11** can operate based on the power supply voltage **VSSA** on the low potential side supplied from the external device **90** through the power supply line **LVSSA** and the terminal **T2**, and the power supply voltage **HVDDA** on the high potential side supplied from the external device **90** through the power supply line **LHVDDA** and the terminal **T3**. Therefore, even if the shift voltage ΔV increases due to the GND shift, the physical layer circuit **11** can output a signal in the voltage range where the physical layer circuit of the external device **90** can properly receive the signal, so occurrence of a problem due to the GND shift can be prevented. Also, in the third configuration example shown in FIG. **14**, there is an advantage that it is not necessary for the circuit device **10** to have the voltage generation circuit **60** as in the second configuration example in FIG. **13**.

Note that in FIGS. **13** and **14**, the power supply line **LVBUS**, the data bus **DBS**, and the ground line **LGND** are included in the USB cable, but the power supply line **LVSSA** and the power supply line **LHVDDA** are not defined by the USB specification, and are power supply lines not included in the USB cable. Therefore, in the second and third configuration examples of FIGS. **13** and **14**, there is a disadvantage that it is necessary to separately prepare a special cable having the power supply line **LVSSA** and the power supply line **LHVDDA**. In this regard, in the first configuration example shown in FIG. **7**, there are the advantages that it is not necessary to prepare such a special cable, and the circuit device **10** and the external device **90** can be coupled using an ordinary USB cable. On the other hand, in the second and third configuration examples of FIGS. **13** and **14**, there are the advantages that it is only necessary to provide the terminal **T2** and the terminal **T3** in the circuit device **10**, and it is not necessary to provide the measurement circuit **50** or the like shown in FIG. **7**.

FIG. **15** shows an example of application of the circuit device **10** of the present embodiment to an in-vehicle device. A main controller **110** is a host on the upstream side, and is realized by an SOC (System-On-a-Chip), for example. A portable terminal device **150** such as a smartphone on the downstream side is coupled to the main controller **110** through a cable **130** and a USB receptacle **140**. Also, a Bluetooth (registered trademark) device and an SD card device are coupled to the downstream side of the main controller **110**. In FIG. **15**, the circuit device **10** is provided

between the cable **130** and the USB receptacle **140**, and the main controller **110**. The cable harness **120** can be configured with the circuit device **10** of the present embodiment, the cable **130**, and the like. Note that a charging circuit, an electrostatic protection circuit, and the like that are not shown can be provided between the main controller **110** and the USB receptacle **140**.

In the vehicle-mounted device, the cable **130** becomes very long, and for example, in some instances may be as long as 5 m to 10 m. When the cable length becomes long, the parasitic resistance R_P in FIG. **1** becomes large and ΔV due to the GND shift becomes large, causing the problem described in FIGS. **3** to **6**. In this regard, in the present embodiment, the circuit device **10** is coupled to one end of the cable **130** having a long cable length, and the USB receptacle **140** is coupled to the other end of the cable **130**. A user couples the portable terminal device **150** to the USB receptacle **140** with an ordinary USB cable.

In the circuit device **10** of the present embodiment, as described with reference to FIGS. **1**, **7**, **13**, and **14**, the physical layer circuit **11** operates based on the power supply voltage $VSSA$ on the low potential side differing from the power supply voltage VSS of the ground line $LGND$, and the power supply voltage $HVDDA$ on the high potential side set with reference to the power supply voltage $VSSA$. Therefore, it is possible to make the voltage range of the signal of the physical layer circuit **11** of the circuit device **10** substantially the same as the receivable voltage range of the signal of the physical layer circuit of the portable terminal device **150** serving as the external device **90**. Thus, even when ΔV increases due to the GND shift, it is possible to prevent occurrence of a communications error, and possible to prevent occurrence of a situation where a maximum rating is exceeded.

Note that in the circuit device **10** of FIG. **15**, the physical layer circuit **11** is provided on the downstream side, and a physical layer circuit **12** is also provided on the upstream side. The processing circuit **20** is provided between the physical layer circuit **11** and the physical layer circuit **12**. The circuit device **10** is coupled to the portable terminal device **150** through a first bus to which the physical layer circuit **11** is coupled, and is coupled to the main controller **110** through a second bus to which the physical layer circuit **12** is coupled. Note that the level shifter **18** as shown in FIG. **1** is provided between the physical layer circuit **11** and the processing circuit **20**. Also, a level shifter may be provided between the physical layer circuit **12** and the processing circuit **20**. The processing circuit **20** performs a packet repeat operation similar to a processing circuit of a USB hub. For example, the processing circuit **20** performs processing that transmits a repeat packet of a packet received by the physical layer circuit **12** from the main controller **110** to the portable terminal device **150** by the physical layer circuit **11**. Also, the processing circuit **20** performs processing that transmits a repeat packet of a packet received by the physical layer circuit **11** from the portable terminal device **150** to the main controller **110** by the physical layer circuit **12**. By adopting this sort of configuration, even when the cable length of the cable **130** is long, it is possible to realize a packet transmission/receiving processing in which the influence of the GND shift is kept to a minimum.

Note that in FIG. **15**, an unshown charging circuit that supplies $VBUS$ power can be provided instead of the main controller **110**. Specifically, for example, it is possible to provide a charging circuit that performs operation conforming to the specifications of USB BC 1.2. In BC 1.2, for example, a $VBUS$ power supply limit of 500 mA or less is

expanded to be, for example, 2 A or less. The charging circuit has a regulator circuit or the like, and an external power supply is supplied to supply $VBUS$ power. In BC 1.2, in a charging mediation period after a bus reset, the charging circuit performs signal transfer using the signals DP and DM between the charging circuit and a peripheral device such as the portable terminal device **150**, and the protocol of BC 1.2 is executed to perform charging arbitration processing. After the arbitration processing, an ordinary USB signal sequence following the bus reset is executed. In a case where such a charging circuit is provided, $VBUS$ power supply is performed not by the main controller **110** or the circuit device **10**, but by the charging circuit.

3. Electronic Device and Mobile Body

FIG. **16** shows a configuration example of an electronic device **300** including the circuit device **10** of the present embodiment. The electronic device **300** includes the circuit device **10** of the present embodiment, and the main controller **110** serving as a processing device. The circuit device **10** is coupled to a peripheral device **350** such as the portable terminal device **150** through a first bus, and is coupled to the main controller **110** through a second bus.

The main controller **110** performs control processing of the electronic device **300**, various signal processing, and the like. The main controller **110** can be realized, for example, by a processor such as a CPU or an MPU. Alternatively, the main controller **110** may be realized by an ASIC (Application Specific Integrated Circuit). Also, the main controller **110** may be realized by a circuit board where a plurality of ICs (Integrated Circuits) and circuit components are mounted. As the peripheral device **350**, for example, the portable terminal device **150** as shown in FIG. **15** or the like can be assumed, but the peripheral device **350** is not limited to this. The peripheral device **350** may be a wearable device or the like.

The electronic device **300** can further include a memory **320**, an operation interface **330**, and a communications interface **340**. The memory **320** stores, for example, data from the operation interface **330** and the communications interface **340**, or alternatively functions as a work memory of the main controller **110**. The memory **320** can be realized by a semiconductor memory such as a RAM (Random Access Memory) or a ROM (Read Only Memory), or a magnetic storage device such as a hard disk drive. The operation interface **330** is a user interface that accepts various operations from a user. For example, the operation interface **330** can be realized by various buttons, a touch panel, or the like. The communications interface **340** is an interface that performs communications of various data such as control data and image data. The communications processing of the communications interface **340** may be wired communications processing, or may be wireless communications processing.

Specific examples of the electronic device **300** include various electronic devices, such as in-vehicle devices such as a car navigation device, an in-vehicle audio device or an instrument panel, or a projector, a head mounted display, a printing device, a portable information terminal, a portable game terminal, a robot, or alternatively an information processing device or the like. Alternatively, the electronic device **300** may be a biological information measurement device, a measurement device that measures physical quantities such as distance, time, flow rate or flow amount, a network-related device such as a base station or a router, a content providing device that distributes content, or alternatively may be a video device such as a digital camera or a video camera.

FIG. 17 shows a configuration example of a mobile body including the circuit device 10 of the present embodiment. The mobile body is, for example, a device or apparatus that moves on the ground, in the sky, or the sea, and is equipped with a drive mechanism such as an engine or a motor, a steering mechanism such as a steering wheel or a rudder, and various electronic devices. As the mobile body of the present embodiment, it is possible to assume, for example, a car, an airplane, a motorcycle, a ship, or alternatively a robot or the like. FIG. 17 schematically shows an automobile 206 as a specific example of the mobile body. The automobile 206 has a vehicle body 207 and wheels 209. The automobile 206 includes an in-vehicle device 220 having the circuit device 10, and a control device 210 controlling each part of the automobile 206. The control device 210 can include, for example, an ECU (Electronic Control Unit) or the like. The circuit device 10 of the present embodiment may be provided in the control device 210. The in-vehicle device 220, for example, is a car navigation device, an in-vehicle audio device, or alternatively a panel device such as an instrument panel, or the like.

As described above, the circuit device of the present embodiment includes a physical layer circuit coupled to a data bus, and a processing circuit that controls the physical layer circuit and performs communications processing through the data bus. The processing circuit operates with a voltage supplied from a ground line as a power supply voltage on a low potential side, and the physical layer circuit operates based on a first power supply voltage on the low potential side supplied from a first power supply line not coupled to the ground line in the circuit device, and a second power supply voltage on a high potential side set with reference to the first power supply voltage.

According to the present embodiment, the physical layer circuit coupled to the data bus is controlled by the processing circuit to perform communications through the data bus. The processing circuit operates with the voltage supplied from the ground line as the power supply voltage on the low potential side. On the other hand, the physical layer circuit operates based on the first power supply voltage on the low potential side supplied from the first power supply line, and the second power supply voltage on the high potential side set with reference to the first power supply voltage. The first power supply line that supplies the first power supply voltage to the physical layer circuit, and the ground line that supplies the power supply voltage to the processing circuit, are not coupled in the circuit device. By adopting this sort of configuration, even when a GND shift occurs in the ground line, it is possible to prevent this GND shift from affecting the power supply voltage that operates the physical layer circuit. Therefore, even when the GND shift occurs, it is possible to properly operate the physical layer circuit, and it is possible to prevent the occurrence of problems caused by the GND shift.

The circuit device of the present embodiment may further include a level shifter that is provided between the physical layer circuit and the processing circuit, and shifts the signal level of a signal from the processing circuit to the physical layer circuit and the signal level of a signal from the physical layer circuit to the processing circuit.

By adopting this sort of configuration, even when the physical layer circuit is operated by the first and second power supply voltages, it is possible to transmit a signal from the processing circuit to the physical layer circuit at an appropriate signal level, and possible to transmit a signal from the physical layer circuit to the processing circuit at an appropriate signal level.

The circuit device of the present embodiment may further include a measurement circuit that measures the voltage of the data bus, and a voltage generation circuit that generates the first power supply voltage based on a measurement result of the measurement circuit, and generates the second power supply voltage with reference to the generated first power supply voltage.

By adopting this sort of configuration, a shift voltage generated by a GND shift can be measured by the measurement circuit, and the first and second power supply voltages can be generated by the voltage generation circuit. Also, by operating the physical layer circuit based on the generated first and second power supply voltages, it is possible to prevent the occurrence of problems caused by the GND shift.

Also, in the circuit device of the present embodiment, a configuration may be adopted in which the physical layer circuit includes an HS driver serving as a USB HS mode transmission circuit, the data bus includes a DP signal line that transmits a USB signal DP and a DM signal line that transmits a USB signal DM, and the measurement circuit measures the voltage of at least one of the DP signal line and the DM signal line of the data bus coupled to the HS driver.

By adopting this sort of configuration, by measuring the voltage of at least one of the DP signal line and the DM signal line coupled to the HS driver in the HS mode, the shift voltage generated by the GND shift can be measured by the measurement circuit.

Also, in the circuit device of the present embodiment, the measurement circuit may measure the voltage of the DP signal line or the DM signal line in a period when a USB packet is not being communicated.

By adopting this sort of configuration, it is possible to measure the shift voltage due to the GND shift by effectively utilizing the period when a USB packet is not being communicated, so it is possible to prevent a situation in which the measurement by the measurement circuit affects USB packet communications.

Also, in the circuit device of the present embodiment, a configuration may be adopted in which the circuit device of the present embodiment includes a first terminal coupled to the ground line and a second terminal coupled to the first power supply line that supplies the first power supply voltage, and the physical layer circuit operates based on the first power supply voltage supplied from outside of the circuit device to the second terminal through the first power supply line.

By adopting this sort of configuration, it is possible to supply the first power supply voltage from outside of the circuit device to the circuit device through the second terminal, and operate the physical layer circuit based on the first power supply voltage, so it is possible to prevent the occurrence of problems caused by the GND shift.

Also, the circuit device of the present embodiment may include a voltage generation circuit that generates the second power supply voltage with reference to the first power supply voltage supplied to the second terminal.

By adopting this sort of configuration, it is possible to generate the second power supply voltage with reference to the first power supply voltage supplied to the second terminal, and supply the second power supply voltage to the physical layer circuit.

Also, in the circuit device of the present embodiment, a configuration may be adopted in which the circuit device includes a third terminal coupled to a second power supply line that supplies the second power supply voltage, and the physical layer circuit operates based on the second power

supply voltage supplied from outside of the circuit device to the third terminal through the second power supply line.

By adopting this sort of configuration, in addition to the first power supply voltage, it is possible to supply the second power supply voltage from outside of the circuit device to the circuit device through the third terminal, and operate the physical layer circuit based on the first and second power supply voltages, so it is possible to prevent the occurrence of problems caused by the GND shift.

Also, an electronic device of the present embodiment may include the above-described circuit device. Also, a mobile body of the present embodiment may include the above-described circuit device.

Note that although the present embodiment has been described in detail above, it will be easily understood by those skilled in the art that many modifications that do not substantially deviate from novel matters and effects of the disclosure are possible. Accordingly, all such modifications are encompassed by the disclosure. For example, in the specification or the drawings, a term described at least once together with a different term having a broader or equivalent meaning can be replaced with the different term at any point in the specification or the drawings. Also, all combinations of the present embodiment and modifications are encompassed by the disclosure. Also, the configuration, operation, and the like of the circuit device, the electronic device, and the mobile body are not limited to those described in the present embodiment, and various modified embodiments are possible.

What is claimed is:

1. A circuit device, comprising:
 a physical layer circuit coupled to a data bus;
 a processing circuit that controls the physical layer circuit and performs communications processing through the data bus, wherein
 the processing circuit operates with a voltage of a ground line as a power supply voltage on a low potential side, and
 the physical layer circuit operates based on a first power supply voltage on the low potential side supplied from a first power supply line not coupled to the ground line in the circuit device, and a second power supply voltage on a high potential side set with reference to the first power supply voltage;
 a measurement circuit that measures the voltage of the data bus; and
 a voltage generation circuit that generates the first power supply voltage based on a measurement result of the measurement circuit, and generates the second power supply voltage with reference to the generated first power supply voltage.
2. The circuit device according to claim 1, comprising:
 a level shifter that shifts the signal level of a signal from the processing circuit to the physical layer circuit and the signal level of a signal from the physical layer circuit to the processing circuit.

3. The circuit device according to claim 1, wherein the physical layer circuit includes a high speed driver serving as a Universal Serial Bus (USB) high speed mode transmission circuit,

the data bus includes a data plus (DP) signal line that transmits a USB signal DP and a data minus (DM) signal line that transmits a USB signal DM, and the measurement circuit measures the voltage of at least one of the DP signal line and the DM signal line of the data bus coupled to the high speed driver.

4. The circuit device according to claim 3, wherein the measurement circuit measures the voltage of the DP signal line or the DM signal line in a period when a USB packet is not being communicated.

5. An electronic device, comprising:
 the circuit device according to claim 1.

6. A mobile body, comprising:
 the circuit device according to claim 1.

7. A circuit device, comprising:
 a physical layer circuit coupled to a data bus;
 a processing circuit that controls the physical layer circuit and performs communications processing through the data bus, wherein

the processing circuit operates with a voltage of a ground line as a power supply voltage on a low potential side, and

the physical layer circuit operates based on a first power supply voltage on the low potential side supplied from a first power supply line not coupled to the ground line in the circuit device, and a second power supply voltage on a high potential side set with reference to the first power supply voltage;

a first terminal coupled to the ground line; and
 a second terminal coupled to the first power supply line that supplies the first power supply voltage, wherein the physical layer circuit operates based on the first power supply voltage supplied from outside of the circuit device to the second terminal.

8. The circuit device according to claim 7, comprising:
 a voltage generation circuit that generates the second power supply voltage with reference to the first power supply voltage supplied to the second terminal.

9. The circuit device according to claim 7, comprising:
 a third terminal coupled to a second power supply line that supplies the second power supply voltage, wherein the physical layer circuit operates based on the second power supply voltage supplied from outside of the circuit device to the third terminal through the second power supply line.

10. An electronic device, comprising:
 the circuit device according to claim 7.

11. A mobile body, comprising:
 the circuit device according to claim 7.

* * * * *