



(11) **EP 3 347 619 B1**

(12) **EUROPEAN PATENT SPECIFICATION**

(45) Date of publication and mention of the grant of the patent:
28.10.2020 Bulletin 2020/44

(21) Application number: **15903700.1**

(22) Date of filing: **09.09.2015**

(51) Int Cl.:
F16H 3/66 (2006.01)

(86) International application number:
PCT/SE2015/050946

(87) International publication number:
WO 2017/044019 (16.03.2017 Gazette 2017/11)

(54) **A TRANSMISSION ARRANGEMENT FOR A VEHICLE**

GETRIEBEANORDNUNG FÜR EIN FAHRZEUG

AGENCEMENT DE TRANSMISSION POUR UN VÉHICULE

(84) Designated Contracting States:
AL AT BE BG CH CY CZ DE DK EE ES FI FR GB GR HR HU IE IS IT LI LT LU LV MC MK MT NL NO PL PT RO RS SE SI SK SM TR

(43) Date of publication of application:
18.07.2018 Bulletin 2018/29

(73) Proprietor: **Volvo Construction Equipment AB**
631 85 Eskilstuna (SE)

(72) Inventors:
• **DERSJÖ, Jan**
S-633 47 Eskilstuna (SE)
• **MATTSSON, Per**
294 91 Sölvesborg (SE)
• **LEHIKONEN, Mathias**
S-723 44 Västerås (SE)
• **ÅKERBLOM, Mats**
S-635 06 Eskilstuna (SE)

• **MÜLLER, Jörg**
09116 Chemnitz (DE)
• **LEESCH, Mirko**
09423 Gelenau (DE)
• **RESCH, Rico**
09128 Chemnitz (DE)

(74) Representative: **Kransell & Wennborg KB**
P.O. Box 2096
403 12 Göteborg (SE)

(56) References cited:
WO-A1-02/079669 **WO-A1-2013/159991**
WO-A1-2013/159996 **WO-A1-2013/160000**
WO-A1-2015/039768 **DE-A1-102006 026 597**
SE-C2- 527 108 **US-A1- 2007 129 205**
US-A1- 2007 129 206 **US-A1- 2008 039 266**
US-A1- 2011 105 267

EP 3 347 619 B1

Note: Within nine months of the publication of the mention of the grant of the European patent in the European Patent Bulletin, any person may give notice to the European Patent Office of opposition to that patent, in accordance with the Implementing Regulations. Notice of opposition shall not be deemed to have been filed until the opposition fee has been paid. (Art. 99(1) European Patent Convention).

Description

TECHNICAL FIELD

5 **[0001]** The present invention relates to a transmission arrangement for a vehicle. The invention also relates to a vehicle comprising such a transmission arrangement. The invention is applicable on vehicles, in particularly working machines such as e.g. wheel loaders, articulated haulers, dump trucks, etc. Although the invention will mainly be described in relation to an articulated hauler, it may also be applicable for other types of vehicles such as e.g. trucks.

10 BACKGROUND

[0002] In connection with transportation of heavy loads at construction sites or the like, a working machine is often used. The working machines may be utilized for transportations in connection with road or tunnel building, sand pits, mines, forestry and similar environments. Thus, the working machine is frequently operated with large and heavy loads in rough terrain and on slippery ground where no regular roads are present.

15 **[0003]** In order to fulfil the desired demands from the fields where the working machine is frequently operated, high performance of the vehicle gearbox is necessary. The gearbox is arranged for adjusting the speed and tractive effort of the vehicle in dependency of the specific driving scenario. The gearbox comprises a transmission arrangement and depending on the specific type of gearbox, the transmission arrangement may comprise e.g. ordinary gear sets with cylindrical gear wheels in meshed connection with each other or planetary gear sets comprising a respective sun gear, ring gear and a planet carrier, or a combination of ordinary gear sets and one or more planetary gear sets.

20 **[0004]** US 2008/039266 A1 discloses, in the opinion of the Examining Division of the European Patent Office, a transmission arrangement for a vehicle, the transmission arrangement comprising a first, a second, a third, and a fourth planetary gear set comprising a sun gear, a planet carrier and a ring gear, respectively, wherein said transmission arrangement further comprises a transmission housing, an input shaft and an output shaft, wherein the ring gear of the first planetary gear set and the input shaft are operatively connected to each other; the sun gear of the first planetary gear set and the sun gear of the second planetary gear set are operatively connected to each other; the sun gear of the third planetary gear set and the sun gear of the fourth planetary gear set are operatively connected to each other; and the planet carrier of the fourth planetary gear set and the output shaft are operatively connected to each other, wherein
25 the transmission arrangement further comprises: a first connecting mechanism for selectively connecting the ring gear of the second planetary gear set to the ring gear of the first planetary gear set and to the input shaft; a first locking mechanism for selectively locking the ring gear of the fourth planetary gear set to the transmission housing; a second locking mechanism for selectively locking the sun gear of the third planetary gear set and the sun gear of the fourth planetary gear set to the transmission housing; and wherein the stationary gear ratio of each one of the first, second, third and fourth planetary gear sets are negative.

30 **[0005]** SE 527 108 describes a vehicle transmission arrangement, particularly suitable for working machines. The transmission arrangement in SE 527 108 comprises an input shaft and an output shaft. Five planetary gear sets are arranged between the input shaft and the output shaft for providing the desired gear ratios. Also, the transmission arrangement comprises three clutches and five brakes for achieving the desired gear shifts. Hereby, nine forward gears and four reverse gears are provided for the transmission arrangement in SE 527 108.

35 **[0006]** Although the transmission arrangement in SE 527 108 provides for a sufficient number of gears, the transmission arrangement is still in need of further improvements in terms of costs and functionality.

SUMMARY

45 **[0007]** It is an object of the present invention to provide a transmission arrangement that enables fewer components to be used and has an improved gear shiftability in comparison to the prior art. The object is at least partly achieved by a transmission arrangement according to claim 1.

50 **[0008]** According to a first aspect of the present invention, there is provided a transmission arrangement for a vehicle, the transmission arrangement comprising a first, a second, a third, and a fourth planetary gear set comprising a sun gear, a planet carrier and a ring gear, respectively, wherein the transmission arrangement further comprises a transmission housing, an input shaft and an output shaft, wherein the ring gear of the first planetary gear set and the input shaft are operatively connected to each other; the sun gear of the first planetary gear set and the sun gear of the second planetary gear set are operatively connected to each other; the planet carrier of the second planetary gear set and the ring gear of the third planetary gear set are operatively connected to each other; the planet carrier of the third planetary gear set is operatively connected to the transmission housing; the sun gear of the third planetary gear set and the sun gear of the fourth planetary gear set are operatively connected to each other; and the planet carrier of the fourth planetary gear set and the output shaft are operatively connected to each other.

5 [0009] The wording "operatively connected to" should in the following and throughout the entire description be interpreted such that the components thereof are fixedly connected to each other, i.e. the rotational speeds of the components which are operatively connected to each other are equal. Hence, no engagement and disengagement mechanism or the like is arranged between the components that are operatively connected to each other and they can therefore not be disengaged from one another during operation. Accordingly, the planet carrier of the fourth planetary gear set is always connected to the output shaft of the transmission arrangement.

10 [0010] An advantage of the present invention is that, in comparison to the prior art, only four planetary gear sets are used in order to obtain a sufficient number of forward and reverse gears. This is advantageous both in terms of cost and packaging of the transmission arrangement since the number of components reduces the total cost for the transmission arrangement at the same time as it will be easier to fit the transmission arrangement to a vehicle. The engine compartment is an environment where it often is desirable to reduce the size of the components housed therein and the present invention hence reduces the size of the transmission arrangement by having one less planetary gear set in comparison to the prior art.

15 [0011] Moreover, by means of the present invention, nine forward gears and three reverse gears are obtainable, where the ratios and the steps for the different gears are considered to be able to appropriately operate e.g. a working machine to provide sufficient speed when necessary and sufficient torque when necessary. The ratio and step for the different obtainable gears will be described further below in relation to the detailed description of the present invention.

20 [0012] A still further advantage is that further additional gears and alternative gears in addition to the nine forward gears and the three reverse gears described above are obtainable. These additional gears and alternative gears will also be described further below in relation to the detailed description of the present invention.

25 [0013] According to the invention, the transmission arrangement may comprise a first connecting mechanism for selectively connecting the ring gear of the second planetary gear set to the ring gear of the first planetary gear set and to the input shaft. The first connecting mechanism may, for example, be a clutch arrangement, such as e.g. a wet or dry friction disc clutch. Other alternatives are also conceivable, such as a dog clutch.

[0014] The wording "selectively connectable to" should be understood to mean that the components thereof are connectable to each other such that, when being connected to each other, the components have equal rotational speeds. Hence, the components may be directly connectable to each other or via another component.

30 [0015] According to the invention, the transmission arrangement may comprise a second connecting mechanism for selectively connecting the planet carrier of the first planetary gear set to the output shaft and to the planet carrier of the fourth planetary gear set. The second connecting mechanism may, for example, be a clutch arrangement, such as e.g. a wet or dry friction disc clutch. Other alternatives are of course also conceivable.

35 [0016] According to the invention, the transmission arrangement may comprise a third connecting mechanism for selectively connecting the ring gear of the fourth planetary gear set to the sun gear of the first planetary gear set and to the sun gear of the second planetary gear set. The third connecting mechanism may, for example, be a clutch arrangement, such as e.g. a wet or dry friction disc clutch. Other alternatives are of course also conceivable.

[0017] According to the invention, the transmission arrangement may comprise a fourth connecting mechanism for selectively connecting the planet carrier of the first planetary gear set to the ring gear of the fourth planetary gear set. The fourth connecting mechanism may, for example, be a clutch arrangement, such as e.g. a wet or dry friction disc clutch. Other alternatives are of course also conceivable.

40 [0018] According to the invention, the transmission arrangement may comprise a first locking mechanism for selectively locking the ring gear of the fourth planetary gear set to the transmission housing. The first locking mechanism may, for example, be a brake arrangement, such as e.g. a wet or dry friction disc brake. Other alternatives are also conceivable such as a dog clutch.

45 [0019] According to an example embodiment, the ring gear of the fourth planetary gear set may be selectively connectable to the transmission housing via the planet carrier of the third planetary gear set.

[0020] Accordingly, since the planet carrier of the third planetary gear set is operatively connected to the transmission housing, the ring gear of the fourth planetary gear set can hence be locked to the transmission housing via the planet carrier of the third planetary gear set such that the ring gear of the fourth planetary gear set is prevented from rotating.

50 [0021] According to the invention, the transmission arrangement may comprise a second locking mechanism for selectively locking the sun gear of the third planetary gear set and the sun gear of the fourth planetary gear set to the transmission housing. The second locking mechanism may, for example, be a brake arrangement, such as e.g. a wet or dry friction disc brake. Other alternatives are of course also conceivable.

55 [0022] According to an example embodiment, the sun gear of the third planetary gear set and the sun gear of the fourth planetary gear set may be selectively connectable to the transmission housing via the planet carrier of the third planetary gear set.

[0023] Accordingly, since the planet carrier of the third planetary gear set is operatively connected to the transmission housing, the sun gear of the third planetary gear set and the sun gear of the fourth planetary gear set can hence be locked to the planet carrier of the third planetary gear set for preventing rotation of the sun gear of the third planetary

gear set and the sun gear of the fourth planetary gear set.

[0024] According to the invention, the transmission arrangement may comprise a third locking mechanism for selectively locking the ring gear of the second planetary gear set to the transmission housing. The third locking mechanism may, for example, be a brake arrangement, such as e.g. a wet or dry friction disc brake. Other alternatives are of course also conceivable.

[0025] Hereby, the ring gear of the second planetary gear set can hence be locked to the transmission housing such that the ring gear is prevented from rotating.

[0026] According to the invention, the stationary gear ratio of each one of the first, second, third and fourth planetary gear sets may be negative. An advantage is that single planet wheels are used, which reduces cost and gear mesh losses.

[0027] According to a second aspect of the present invention there is provided a method for controlling a transmission arrangement, the transmission arrangement comprising a first, a second, a third, and a fourth planetary gear set comprising a sun gear, a planet carrier and a ring gear, respectively, wherein the transmission arrangement further comprises a transmission housing, an input shaft and an output shaft; the ring gear of the first planetary gear set being operatively connected to the input shaft; the sun gear of the first planetary gear set being operatively connected to the sun gear of the second planetary gear set; the planet carrier of the second planetary gear set being operatively connected to the ring gear of the third planetary gear set; the planet carrier of the third planetary gear set being operatively connected to the transmission housing; the sun gear of the third planetary gear set being operatively connected to the sun gear of the fourth planetary gear set; the planet carrier of the fourth planetary gear set being operatively connected to the output shaft, wherein the transmission arrangement further comprises: a first connecting mechanism for selectively connecting the ring gear of the second planetary gear set to the ring gear of the first planetary gear set and to the input shaft; a second connecting mechanism for selectively connecting the planet carrier of the first planetary gear set to the output shaft and to the planet carrier of the fourth planetary gear set; a third connecting mechanism for selectively connecting the ring gear of the fourth planetary gear set to the sun gear of the first planetary gear set and to the sun gear of the second planetary gear set; a fourth connecting mechanism for selectively connecting the planet carrier of the first planetary gear set to the ring gear of the fourth planetary gear set; a first locking mechanism for selectively locking the ring gear of the fourth planetary gear set to the transmission housing; a second locking mechanism for selectively locking the sun gear of the third planetary gear set and the sun gear of the fourth planetary gear set to the transmission housing; and a third locking mechanism for selectively locking the ring gear of the second planetary gear set to the transmission housing, wherein for at least one of the gears of the transmission arrangement, the method comprises the steps of: positioning three of the locking and connecting mechanisms in an engaged state; and positioning four of the locking and connecting mechanisms in a disengaged state.

[0028] Hereby, the majority of elements are disengaged for the different gears of the transmission arrangement, which thus may increase durability of friction components etc.

[0029] According to an example embodiment, the method may comprise the step of positioning the first and the third locking mechanisms, and the second connecting mechanism in an engaged state when engaging a first forward gear. According to an example embodiment, the method may comprise the step of positioning the first and the third locking mechanisms, and the fourth connecting mechanism in an engaged state when engaging a second forward gear. According to an example embodiment, the method may comprise the step of positioning the third locking mechanism, and the second and the fourth connecting mechanisms in an engaged state when engaging a third forward gear. According to an example embodiment, the method may comprise the step of positioning the second and the third locking mechanisms, and the fourth connecting mechanism in an engaged state when engaging a fourth forward gear. According to an example embodiment, the method may comprise the step of positioning the third locking mechanism, and the third and the fourth connecting mechanisms in an engaged state when engaging a fifth forward gear. According to an example embodiment, the method may comprise the step of positioning the second locking mechanism, and the third and the fourth connecting mechanisms in an engaged state when engaging a sixth forward gear. According to an example embodiment, the method may comprise the step of positioning the second, the third and the fourth connecting mechanisms in an engaged state when engaging a seventh forward gear. According to an example embodiment, the method may comprise the step of positioning the second locking mechanism, and the second and the third connecting mechanisms in an engaged state when engaging an eighth forward gear. According to an example embodiment, the method may comprise the step of positioning the third locking mechanism, and the second and the third connecting mechanisms in an engaged state when engaging a ninth forward gear.

[0030] Thus, well defined forward gears are provided for the transmission arrangement.

[0031] According to an example embodiment, the method may comprise the step of positioning the first locking mechanism, and the first and the second connecting mechanisms in an engaged state when engaging a first reverse gear; According to an example embodiment, the method may comprise the step of positioning the first locking mechanism, and the first and the fourth connecting mechanisms in an engaged state when engaging a second reverse gear. According to an example embodiment, the method may comprise the step of positioning the first locking mechanism, and the first and the third connecting mechanisms in an engaged state when engaging a third reverse gear.

[0032] Thus, well defined reverse gears are provided for the transmission arrangement. All one-step gear shifts as well as all two-step gear shifts for the forward gears and the reverse gears are performed by only shifting one of the connecting and locking mechanisms from an engaged state to a disengaged state, and only shifting one of the connecting and locking mechanisms from a disengaged state to an engaged state.

5 [0033] According to an example embodiment, the method may comprise the step of positioning the second and the third locking mechanisms, and the second connecting mechanism in an engaged state when engaging a first additional forward gear having a gear ratio between the gear ratios of the fifth and the sixth forward gears.

10 [0034] Hereby, a further gear is arranged between the fifth and sixth forward gears which provides for an additional step between the fifth and sixth gears. A gear shift can be executed from the fourth forward gear to the first additional forward gear. This will provide for a smaller step in comparison to a gear shift from the fourth forward gear to the sixth forward gear. Further, when executing a gear shift from the fourth forward gear to the first additional forward gear only one of the connecting and locking mechanisms are changed from an engaged state to a disengaged state, and only one of the connecting and locking mechanisms are changed from a disengaged state to an engaged state. Still further, the first additional forward gear has high gear mesh efficiency.

15 [0035] According to an example embodiment, the method may comprise the step of positioning the first, second and third connecting mechanisms in an engaged state when engaging a second additional forward gear having a gear ratio lower than the gear ratio of the ninth forward gear.

20 [0036] Hereby, an additional gear is provided which can increase the vehicle speed even further in comparison to the ninth forward gear. An advantage is thus that the vehicle may be able to drive at a faster speed in situations where this is desirable.

[0037] According to an example embodiment, the method may comprise the step of positioning the first, second and fourth connecting mechanisms in an engaged state when engaging a first additional reverse gear having a gear ratio between the second and the third reverse gears.

25 [0038] According to an example embodiment, the method may comprise the step of positioning the second locking mechanism, and the first and the fourth connecting mechanisms in an engaged state when engaging a second additional reverse gear having a gear ratio between the second and the third reverse gears.

[0039] According to an example embodiment, the method may comprise the step of positioning the second locking mechanism, and the first and the second connecting mechanisms in an engaged state when engaging a third additional reverse gear having a gear ratio lower than the gear ratio of the third reverse gear in terms of absolute values.

30 [0040] Hereby, three additional reverse gears are obtained. It has been realized that the third reverse gear can be removed when providing the three additional reverse gears which, thus provides five reverse gears for the transmission arrangement. These five reverse gears have beneficial steps and all one-step gear shifts as well as all two-step gear shifts are performed by only shifting one of the connecting and locking mechanisms from an engaged state to a disengaged state, and only shifting one of the connecting and locking mechanisms from a disengaged state to an engaged state.

35 [0041] Also, the third additional reverse gear enables for a further increased reverse vehicle speed. Hence, the vehicle is able to reverse at a faster speed if desired.

[0042] It should be readily understood that the above defined example embodiments of forward and reverse gears may be combined in any suitable combination.

40 [0043] Further effects and features of the second aspect of the present invention are largely analogous to those described above in relation to the first aspect of the present invention.

45 [0044] According to a third aspect of the present invention there is provided a control unit configured to control a transmission arrangement, the transmission arrangement comprising a first, a second, a third, and a fourth planetary gear set comprising a sun gear, a planet carrier and a ring gear, respectively, wherein said transmission arrangement further comprises a transmission housing, an input shaft and an output shaft, wherein the ring gear of the first planetary gear set being operatively connected to the input shaft; the sun gear of the first planetary gear set being operatively connected to the sun gear of the second planetary gear set; the planet carrier of the second planetary gear set being operatively connected to the ring gear of the third planetary gear set; the planet carrier of the third planetary gear set being operatively connected to the transmission housing; the sun gear of the third planetary gear set being operatively connected to the sun gear of the fourth planetary gear set; the planet carrier of the fourth planetary gear set being operatively connected to the output shaft, wherein the transmission arrangement further comprises a first connecting mechanism for selectively connecting the ring gear of the second planetary gear set to the ring gear of the first planetary gear set and to the input shaft; a second connecting mechanism for selectively connecting the planet carrier of the first planetary gear set to the output shaft and to the planet carrier of the fourth planetary gear set; a third connecting mechanism for selectively connecting the ring gear of the fourth planetary gear set to the sun gear of the first planetary gear set and to the sun gear of the second planetary gear set; a fourth connecting mechanism for selectively connecting the planet carrier of the first planetary gear set to the ring gear of the fourth planetary gear set; a first locking mechanism for selectively locking the ring gear of the fourth planetary gear set to the transmission housing; a second locking mechanism for selectively locking the sun gear of the third planetary gear set and the sun gear of the fourth planetary

gear set to the transmission housing; and a third locking mechanism for selectively locking the ring gear of the second planetary gear set to the transmission housing, wherein for at least one of the gears of the transmission arrangement, the control unit is configured to position three of the locking and connecting mechanisms in an engaged state; and position four of the locking and connecting mechanisms in a disengaged state.

5 [0045] Effects and features of the third aspect of the present invention are largely analogous to those described above in relation to the first and second aspects of the present invention.

[0046] According to a fourth aspect of the present invention there is provided a vehicle comprising a prime mover and a gearbox, wherein the gearbox comprises a transmission arrangement according to any one of the embodiments described above in relation to the first aspect of the present invention.

10 [0047] Effects and features of the fourth aspect of the present invention are largely analogous to those described above in relation to the first, second and third aspects of the present invention.

DEFINITIONS

15 [0048] The relationship between the rotational speeds of the different members in a planetary gear set is defined according to the following:

$$\frac{\omega_S - \omega_P}{\omega_R - \omega_P} = R \quad (\text{Eq. 1})$$

20

wherein

- ω_S is the speed of rotation of the sun gear;
- ω_P is the speed of rotation of the planet carrier;
- 25 ω_R is the speed of rotation of the ring gear; and
- R is the stationary gear ratio of the planetary gear set.

25

[0049] As used herein, the expression "stationary gear ratio" R for a planetary gear set is defined as the ratio of the speed of rotation of the sun gear to the speed of rotation of the ring gear in a situation in which the planet carrier is stationary, i.e.:

30

$$R = -\frac{Z_R}{Z_S} \quad \text{for single planet gear wheels} \quad (\text{Eq. 2})$$

35

and

$$R = +\frac{Z_R}{Z_S} \quad \text{for double planet gear wheels} \quad (\text{Eq. 3})$$

40

wherein

- Z_R is the number of teeth of the ring gear; and
- Z_S is the number of teeth of the sun gear.

45

[0050] In a similar manner, the expression "ratio" for a transmission arrangement should be understood to relate to the number of revolutions of the input shaft of the transmission arrangement divided by the number of revolutions of the output shaft of the transmission arrangement. Furthermore, the expression "step" should be understood to mean the quotient achieved when the ratio of a gear is divided by the ratio of an adjacent gear of a transmission arrangement.

50

BRIEF DESCRIPTION OF THE DRAWINGS

[0051] The above, as well as additional objects, features and advantages of the present invention, will be better understood through the following illustrative and non-limiting detailed description of exemplary embodiments of the present invention, wherein:

55

Fig. 1 is a lateral side view illustrating a working machine in the form of an articulated hauler; and

Fig. 2 schematically illustrates a transmission arrangement according to an example embodiment of the present invention.

DETAILED DESCRIPTION OF EXAMPLE EMBODIMENTS OF THE INVENTION

[0052] The present invention will now be described more fully hereinafter with reference to the accompanying drawings, in which exemplary embodiments of the invention are shown. The invention may, however, be embodied in many different forms and should not be construed as limited to the embodiments set forth herein; rather, these embodiments are provided for thoroughness and completeness. Like reference character refer to like elements throughout the description.

[0053] Fig. 1 is a side view of a working machine 201 in the form of an articulated hauler having a tractor unit 202 with a cab 203 for a driver and a trailer unit 204 with a platform having a dump body 205, here in the form of a container, arranged thereon, for receiving load. The dump body 205 is preferably pivotally connected to the rear section and tiltable by means of a pair of tilting cylinders 206, for example hydraulic cylinders. The tractor unit 202 has a frame 207 and a pair of wheels 208 suspended from the frame 207. The trailer unit 204 has a frame 209 and two pair of wheels 210, 211 suspended from the frame 209.

[0054] The working machine is frame-steered, i.e. there is a joint arrangement 212 connecting the tractor unit 202 and the trailer unit 204 of the working machine 201. The tractor unit 202 and the trailer unit 204 are pivotally connected to each other for pivoting around a substantially vertical pivot axis 213.

[0055] The working machine preferably comprises a hydraulic system having two hydraulic cylinders 214, steering cylinders, arranged on opposite sides of the working machine for turning the working machine by means of relative movement of the tractor unit 202 and the trailer unit 204. The hydraulic cylinders can, however, be replaced by any other linear actuator for steering the machine, such as an electromechanical linear actuator.

[0056] Furthermore, the articulated hauler comprises a prime mover 216, here illustrated as an internal combustion engine, and a gearbox 218 having a transmission arrangement according to the example embodiment described below in relation to Fig. 2. Still further, the articulated hauler also comprises a control unit 600 connected to the gearbox for controlling the below described transmission arrangement. The control unit 600 may be, or form part of, already existing control units for controlling a gearbox.

[0057] Now, with reference to Fig. 2, an example embodiment of a transmission arrangement 100 according to the present invention is illustrated. The transmission arrangement 100 comprises a first planetary gear set 102 comprising a sun gear 102S, a planet carrier 102P and a ring gear 102R, a second planetary gear set 104 comprising a sun gear 104S, a planet carrier 104P and a ring gear 104R, a third planetary gear set 106 comprising a sun gear 106S, a planet carrier 106P and a ring gear 106R, and a fourth planetary gear set 108 comprising a sun gear 108S, a planet carrier 108P and a ring gear 108R. The transmission arrangement 100 further comprises an input shaft 136 for receiving a rotary motion/torque from the prime mover 216 of the vehicle 201 and an output shaft 112 for providing a rotary motion/torque to the driven wheels of the vehicle 201.

[0058] The different members of the planetary gear sets 102, 104, 106, 108 of the transmission arrangement 100, i.e. the sun gear, the planet carrier and the ring gear, are in the example embodiment depicted in Fig. 2 configured according to the following. It should be readily understood that the different members described below are connected to each other, either directly, i.e. operatively connected, or via a connecting mechanism, i.e. selectively connectable. The members can be operatively connected to each other by means of e.g. a connector element. Such connector element can be e.g. a solid shaft, a hollow shaft or a drum, or other suitable element for connecting two members to each other, which elements are known to the person skilled in the art. Hence, no explicit explanation is given below in regards to the means connecting the members to each other.

[0059] The input shaft 136 of the transmission arrangement 100 is operatively connected to the ring gear 102R of the first planetary gear set 102, i.e. the input shaft 136 is at all times directly connected to the ring gear 102R of the first planetary gear set 102. The input shaft 136 and the ring gear 102R of the first planetary gear set 102 are further selectively connectable to the ring gear 104R of the second planetary gear set 104 by means of a first connecting mechanism 120. Further, the sun gear 102S of the first planetary gear set 102 is operatively connected to the sun gear 104S of the second planetary gear set 104. Also, the sun gear 102S of the first planetary gear set 102 and the sun gear 104S of the second planetary gear set 104 are selectively connectable to the ring gear 108R of the fourth planetary gear set 108 by means of a third connecting mechanism 124.

[0060] Furthermore, the planet carrier 102P of the first planetary gear set 102 is selectively connectable to the output shaft 112 by means of a second connecting mechanism 122. The planet carrier 102P of the first planetary gear set 102 is also selectively connectable to the ring gear 108R of the fourth planetary gear set 108 by means of a fourth connecting mechanism 126.

[0061] The planet carrier 104P of the second planetary gear set 104 is operatively connected to the ring gear 106R of the third planetary gear set 106. Further, the ring gear 104R of the second planetary gear set 104 is selectively connectable to the transmission housing 160 by means of a third locking mechanism 132. Hence, the third locking

mechanism 132, when being engaged, initially reduces the rotational speed of the ring gear 104R of the second planetary gear set 104, and thereafter locks the ring gear 104R of the second planetary gear set 104 to the transmission housing 160.

[0062] The sun gear 106S of the third planetary gear set 106 is operatively connected to the sun gear 108S of the fourth planetary gear set 108. Further, the planet carrier 106P of the third planetary gear set 106 is operatively connected to the transmission housing 160. Hence, the planet carrier 106P of the third planetary gear set 106 is at all times prevented from rotating. Furthermore, the sun gear 106S of the third planetary gear set 106 and the sun gear 108S of the fourth planetary gear set 108 are selectively connectable to the planet carrier 106P of the third planetary gear set 106 by means of a second locking mechanism 130. Hereby, when engaging the second locking mechanism 130, the sun gear 106S of the third planetary gear set 106 and the sun gear 108S of the fourth planetary gear set 108 are prevented from rotating since the planet carrier 106P of the third planetary gear set 106 is operatively connected to the transmission housing 160.

[0063] The planet carrier 108P of the fourth planetary gear set 108 is operatively connected to the output shaft 112 of the transmission arrangement 100. Further, the ring gear 108R of the fourth planetary gear set 108 is selectively connectable to the planet carrier 106P of the third planetary gear set 106 by means of a first locking mechanism 128. Hereby, when engaging the first locking mechanism 128, the ring gear 108R of the fourth planetary gear set 108 is prevented from rotating since the planet carrier 106P of the third planetary gear set 106 is operatively connected to the transmission housing 160.

[0064] The above described connecting mechanisms may be respective clutch arrangements which are either wet clutches or dry clutches. The locking mechanisms may be constituted by brake arrangements such as e.g. wet or dry brake arrangements.

[0065] According to the example embodiment depicted in Fig. 2, the stationary gear ratio of each one of the first 102, second 104, third 106, and fourth 108 planetary gear sets are negative. According to a non-limiting example, the stationary gear ratio for each of the planetary gear sets may be as described below in Table 1.

Table 1 - Exemplary stationary gear ratios for the embodiment depicted in Fig. 2.

First planetary gear set (102)	Second planetary gear set (104)	Third planetary gear set (106)	Fourth planetary gear set (108)
-1.700	-3.275	-2.075	-2.575

[0066] The above described example embodiment depicted in Fig. 2 is adapted to assume the gears as presented in Table 2 below. As indicated, the transmission arrangement depicted in Fig. 2 assumes nine forward gears and three reverse gears. In Table 2 below, the locking mechanisms are denoted simply as "Brakes" while the connecting mechanisms are denoted simply as "Clutches". A cell marked with a dot indicates an engaged state and a blank cell indicates a disengaged state. Furthermore, Table 2 also indicates non-limiting examples of the gear ratios and steps obtainable by the transmission arrangement for the various gears. The gear ratios and steps presented in Table 2 are derived from the exemplary stationary gear ratios presented in Table 1 above.

Table 2 - Shift diagram, gear ratios and steps for the different gears.

Gear	Brakes			Clutches				Ratio	Step
	128	130	132	120	122	124	126		
1	●		●		●			5.92	
2	●		●				●	4.33	1.37
3			●		●		●	2.80	1.55
4		●	●				●	2.21	1.27
5			●			●	●	1.71	1.29
6		●				●	●	1.39	1.23
7					●	●	●	1.00	1.39
8		●			●	●		0.77	1.30
9			●		●	●		0.58	1.33
R1	●			●	●			-6.39	
R2	●			●			●	-4.68	1.37
R3	●			●		●		-2.25	2.08

[0067] As depicted in Table 2 above, the transmission arrangement in Fig. 2 comprises nine forward gears and three reverse gears (indicated with an R). The switching of gears can preferably be executed by one-step gear shifts or with two-step gear shifts. One-step gear shift should be understood to mean that a gear shift is executed from one gear to the next coming consecutive gear, for example, gear shift from the first gear to the second gear, from the second gear to the third gear, from the third gear to the second gear, etc. Two-step gear shift should be understood to mean that a gear shift is executed to exclude a next coming consecutive gear, for example, gear shift from the first gear to the third gear, from the second gear to the fourth gear, from the third gear to the first gear, etc.

[0068] As can be seen from Table 2, one-step gear shifting includes only single shifts of the connecting mechanisms and the locking mechanisms, i.e. when executing one-step gear shifts, only one of the connecting mechanisms/locking mechanisms is shifted from an engaged state to a disengaged state, and only one of the connecting mechanisms/locking mechanisms is shifted from a disengaged state to an engaged state. As an example, when shifting from the first forward gear to the second forward gear, it is only the second connecting mechanism 122 that is changed from an engaged state to a disengaged state, and only the fourth connecting mechanism 126 that is changed from a disengaged state to an engaged state.

[0069] Furthermore, and as is depicted in Table 2, also two-step gear shifting only includes single shifts of the connecting mechanisms/locking mechanisms, i.e. when executing two-step gear shifts, only one of the connecting mechanisms/locking mechanisms is shifted from an engaged state to a disengaged state, and only one of the connecting mechanisms/locking mechanisms is shifted from a disengaged state to an engaged state. As an example, when shifting from the fourth forward gear to the sixth forward gear, it is only the third locking mechanism 132 that is changed from an engaged state to a disengaged state, and only the third connecting mechanism 124 that is changed from a disengaged state to an engaged state.

[0070] An advantage of the transmission arrangement is hence that the shiftability is improved since a reduced number of connecting mechanisms/locking mechanisms need activation/deactivation during gear shifting. In detail, during both one-step gear shifting and two-step gear shifting, which are the most common gear shift sequences, only single shifts occur.

[0071] Moreover, with the above described example embodiment of the transmission arrangement 100, further additional gears are obtainable. Table 3 below illustrates additional gears which are possible to obtain by the transmission arrangement 100 depicted and described above.

[0072] In Table 3, gear 0.5* is an additional gear with a gear ratio higher than the gear ratio of the first forward gear. Also, forward gears 5.5* and 5.5** are additional gears, both having a gear ratio between the gear ratios of the fifth and sixth forward gears. In the following, gear 5.5** is referred to as the first additional forward gear. Further, forward gear 10* is a second additional forward gear having a gear ratio lower than the gear ratio of the ninth forward gear, which makes the second additional forward gear a faster gear compared to the ninth forward gear.

[0073] Furthermore, gears R2.5* and R2.9* are respective first and second additional reverse gear each having a gear ratio between the gear ratios of the second and third reverse gears. Still further, gears R4* and R5* are respective third and fourth additional reverse gears each having gear ratios lower than the gear ratio of the third reverse gear in terms of absolute values. Hence, the third and fourth additional reverse gears are faster than the third reverse gear, wherein the fourth additional reverse gear is faster than the third additional reverse gear.

Table 3 - Shift diagram, gear ratios and steps for the different gears.

Gear	Brakes			Clutches				Ratio	Step
	128	130	132	120	122	124	126		
0.5*				●		●	●	7.15	
1	●		●		●			5.92	1.21
2	●		●				●	4.33	1.37
3			●		●		●	2.80	1.55
4		●	●				●	2.21	1.27
5			●			●	●	1.71	1.29
5.5*	●				●	●		1.59	1.08
5.5**		●	●		●			1.59	1.00
6		●				●	●	1.39	1.14
7					●	●	●	1.00	1.39
8		●			●	●		0.77	1.30
9			●		●	●		0.58	1.33
10*				●	●	●		0.40	1.45
R1	●			●	●			-6.39	
R2	●			●			●	-4.68	1.37
R2.5*				●	●		●	-3.02	1.55
R2.9*		●		●			●	-2.38	1.27
R3	●			●		●		-2.25	1.06
R4*		●		●	●			-1.71	1.31
R5*		●		●		●		-0.42	4.04

[0074] Hence, with the transmission arrangement depicted and described in relation to Fig. 2, a plurality of additional gears can be achieved. A further advantage is thus that the transmission arrangement according to the present invention has an increased variability when choosing the gears to be used. Thus, a plurality of alternatives is possible when designing gear shifting of the transmission arrangement.

[0075] It is to be understood that the present invention is not limited to the embodiments described above and illustrated in the drawings; rather, the skilled person will recognize that many changes and modifications may be made within the scope of the appended claims. For example, although the present invention has mainly been described in relation to an articulated hauler, the invention should be understood to be equally applicable for any type of vehicle.

Claims

1. A transmission arrangement (100) for a vehicle, the transmission arrangement comprising a first (102), a second (104), a third (106), and a fourth (108) planetary gear set comprising a sun gear, a planet carrier and a ring gear, respectively, wherein said transmission arrangement (100) further comprises a transmission housing (160), an input shaft (136) and an output shaft (112), wherein

- the ring gear (102R) of the first planetary gear set (102) and the input shaft (136) are operatively connected to each other;
- the sun gear (102S) of the first planetary gear set (102) and the sun gear (104S) of the second planetary gear set (104) are operatively connected to each other;
- the planet carrier (104P) of the second planetary gear set (104) and the ring gear (106R) of the third planetary gear set (106) are operatively connected to each other;
- the sun gear (106S) of the third planetary gear set (106) and the sun gear (108S) of the fourth planetary gear set (108) are operatively connected to each other; and
- the planet carrier (108P) of the fourth planetary gear set (108) and the output shaft (112) are operatively connected to each other,
- the planet carrier (106P) of the third planetary gear set (106) is operatively connected to the transmission housing (160), wherein the transmission arrangement (100) further comprises:

- a first connecting mechanism (120) for selectively connecting the ring gear (104R) of the second planetary gear set (104) to the ring gear (102R) of the first planetary gear set (102) and to the input shaft (136);
 - a second connecting mechanism (122) for selectively connecting the planet carrier (102P) of the first planetary gear set (102) to the output shaft (112) and to the planet carrier (108P) of the fourth planetary gear set (108);
 - a third connecting mechanism (124) for selectively connecting the ring gear (108R) of the fourth planetary gear set (108) to the sun gear (102S) of the first planetary gear set (102) and to the sun gear (104S) of the second planetary gear set (104);
 - a fourth connecting mechanism (126) for selectively connecting the planet carrier (102P) of the first planetary gear set (102) to the ring gear (108R) of the fourth planetary gear set (108);
 - a first locking mechanism (128) for selectively locking the ring gear (108R) of the fourth planetary gear set (108) to the transmission housing (160);
 - a second locking mechanism (130) for selectively locking the sun gear (106S) of the third planetary gear set (106) and the sun gear (108S) of the fourth planetary gear set (108) to the transmission housing (160); and
 - a third locking mechanism (132) for selectively locking the ring gear (104R) of the second planetary gear set (104) to the transmission housing (160), wherein the stationary gear ratio of each one of the first (102), second (104), third (106) and fourth (108) planetary gear sets are negative.
2. The transmission arrangement (100) according to claim 1, **characterized in that** the ring gear (108R) of the fourth planetary gear set (108) is selectively connectable to the transmission housing (160) via the planet carrier (106P) of the third planetary gear set (106).
 3. The transmission arrangement (100) according to any one of claims 1 or 2, **characterized in that** the sun gear (106S) of the third planetary gear set (106) and the sun gear (108S) of the fourth planetary gear set (108) are selectively connectable to the transmission housing (160) via the planet carrier (106P) of the third planetary gear set (106).
 4. A method for controlling a transmission arrangement (100) according to any one of claims 1 - 3, the method comprising the steps of:
 - positioning three of the locking and connecting mechanisms in an engaged state; and
 - positioning four of the locking and connecting mechanisms in a disengaged state.
 5. A control unit (600) configured to control a transmission arrangement (100) according to any one of claims 1 - 3, the control unit (600) being configured to:
 - position three of the locking and connecting mechanisms in an engaged state; and
 - position four of the locking and connecting mechanisms in a disengaged state.
 6. A vehicle comprising a prime mover and a gearbox, wherein the gearbox comprises a transmission arrangement according to any one of claims 1 - 3.

Patentansprüche

1. Getriebeanordnung (100) für ein Fahrzeug, wobei die Getriebeanordnung ein erstes (102), ein zweites (104), ein drittes (106) und ein viertes (108) Planetengetriebe umfasst, das jeweils ein Sonnenrad, einen Planetenträger und ein Hohlrad umfasst, wobei die Getriebeanordnung (100) ferner ein Getriebegehäuse (160), eine Antriebswelle (136) und eine Abtriebswelle (112) umfasst, wobei
 - das Hohlrad (102R) des ersten Planetengetriebes (102) und die Antriebswelle (136) betriebsmäßig miteinander verbunden sind;
 - das Sonnenrad (102S) des ersten Planetengetriebes (102) und das Sonnenrad (104S) des zweiten Planetengetriebes (104) betriebsmäßig miteinander verbunden sind;
 - der Planetenträger (104P) des zweiten Planetengetriebes (104) und das Hohlrad (106R) des dritten Planetengetriebes (106) betriebsmäßig miteinander verbunden sind;
 - das Sonnenrad (106S) des dritten Planetengetriebes (106) und das Sonnenrad (108S) des vierten Planetengetriebes (108) betriebsmäßig miteinander verbunden sind; und
 - der Planetenträger (108P) des vierten Planetengetriebes (108) und die Abtriebswelle (112) betriebsmäßig

miteinander verbunden sind,

- der Planetenträger (106P) des dritten Planetengetriebes (106) betriebsmäßig mit dem Getriebegehäuse (160) verbunden sind; wobei die Getriebeanordnung (100) ferner umfasst:

- einen ersten Verbindungsmechanismus (120) zum selektiven Verbinden des Hohlrads (104R) des zweiten Planetengetriebes (104) mit dem Hohlrad (102R) des ersten Planetengetriebes (102) und mit der Antriebswelle (136);

- einen zweiten Verbindungsmechanismus (122) zum selektiven Verbinden des Planetenträgers (102P) des ersten Planetengetriebes (102) mit der Abtriebswelle (112) und mit dem Planetenträger (108P) des vierten Planetengetriebes (108);

- einen dritten Verbindungsmechanismus (124) zum selektiven Verbinden des Hohlrads (108R) des vierten Planetengetriebes (108) mit dem Sonnenrad (102S) des ersten Planetengetriebes (102) und mit dem Sonnenrad (104S) des zweiten Planetengetriebes (104);

- einen vierten Verbindungsmechanismus (126) zum selektiven Verbinden des Planetenträgers (102P) des ersten Planetengetriebes (102) mit dem Hohlrad (108R) des vierten Planetengetriebes (108);

- einen ersten Verriegelungsmechanismus (128) zum selektiven Verriegeln des Hohlrads (108R) des vierten Planetengetriebes (108) mit dem Getriebegehäuse (160);

- einen zweiten Verriegelungsmechanismus (130) zum selektiven Verriegeln des Sonnenrads (106S) des dritten Planetengetriebes (106) und dem Sonnenrad (108S) des vierten Planetengetriebes (108) mit dem Getriebegehäuse (160); und

- einen dritten Verriegelungsmechanismus (132) zum selektiven Verriegeln des Hohlrads (104R) des vierten Planetengetriebes (104) mit dem Getriebegehäuse (160), wobei das stationäre Gangverhältnis von jedem der ersten (102), zweiten (104), dritten (106) und vierten (108) Planetengetriebe negativ ist.

2. Getriebeanordnung (100) nach Anspruch 1, **dadurch gekennzeichnet, dass** das Hohlrad (108R) des vierten Planetengetriebes (108) mit dem Getriebegehäuse (160) über den Planetenträger (106P) des dritten Planetengetriebes (106) selektiv verbindbar ist.

3. Getriebeanordnung (100) nach einem der Ansprüche 1 oder 2, **dadurch gekennzeichnet, dass** das Sonnenrad (106S) des dritten Planetengetriebes (106) und das Sonnenrad (108S) des vierten Planetengetriebes (108) mit dem Getriebegehäuse (160) über den Planetenträger (106P) des dritten Planetengetriebes (106) selektiv verbindbar ist.

4. Verfahren zur Steuerung einer Getriebeanordnung (100) nach einem der Ansprüche 1-3, wobei das Verfahren die folgenden Schritte umfasst:

- Positionieren von drei der Verriegelungs- und Verbindungsmechanismen in einen eingerückten Zustand; und
- Positionieren von vier der Verriegelungs- und Verbindungsmechanismen in einen ausgerückten Zustand.

5. Steuereinheit (600), die konfiguriert ist, um eine Getriebeanordnung (100) nach einem der Ansprüche 1-3 zu steuern, wobei die Steuereinheit (600) konfiguriert ist, um:

- drei der Verriegelungs- und Verbindungsmechanismen in einen eingerückten Zustand zu positionieren; und
- vier der Verriegelungs- und Verbindungsmechanismen in einen ausgerückten Zustand zu positionieren.

6. Fahrzeug umfassend eine Antriebsmaschine und ein Getriebe, wobei das Getriebe eine Getriebeanordnung nach einem der Ansprüche 1-3 umfasst.

Revendications

1. Agencement de transmission (100) pour véhicule, l'agencement de transmission comprenant un premier (102), un deuxième (104), un troisième (106), et un quatrième (108) ensembles d'engrenages planétaires comprenant respectivement un engrenage solaire, un support planétaire et un engrenage annulaire, ledit agencement de transmission (100) comprenant en outre un boîtier de transmission (160), un arbre d'entrée (136) et un arbre de sortie (112),

- l'engrenage annulaire (102R) du premier ensemble d'engrenages planétaires (102) et l'arbre d'entrée (136) étant connectés fonctionnellement l'un à l'autre ;

- l'engrenage solaire (102S) du premier ensemble d'engrenages planétaires (102) et l'engrenage solaire (104S) du deuxième ensemble d'engrenages planétaires (104) étant connectés fonctionnellement l'un à l'autre ;

EP 3 347 619 B1

- 5 - le support planétaire (104P) du deuxième ensemble d'engrenages planétaires (104) et l'engrenage annulaire (106R) du troisième ensemble d'engrenages planétaires (106) étant connectés fonctionnellement l'un à l'autre ;
- l'engrenage solaire (106S) du troisième ensemble d'engrenages planétaires (106) et l'engrenage solaire (108S) du quatrième ensemble d'engrenages planétaires (108) étant connectés fonctionnellement l'un à l'autre ;
- le support planétaire (108P) du quatrième ensemble d'engrenages planétaires (108) et l'arbre de sortie (112) étant connectés fonctionnellement l'un à l'autre,
- le support planétaire (106P) du troisième ensemble d'engrenages planétaires (106) étant connecté fonctionnellement au boîtier de transmission (160), l'agencement de transmission (100) comprenant en outre :
- 10 - un premier mécanisme de connexion (120) pour connecter sélectivement l'engrenage annulaire (104R) du deuxième ensemble d'engrenages planétaires (104) à l'engrenage annulaire (102R) du premier ensemble d'engrenages planétaires (102) et à l'arbre d'entrée (136) ;
- un deuxième mécanisme de connexion (122) pour connecter sélectivement le support planétaire (102P) du premier ensemble d'engrenages planétaires (102) à l'arbre de sortie (112) et au support planétaire (108P) du quatrième ensemble d'engrenages planétaires (108) ;
15 - un troisième mécanisme de connexion (124) pour connecter sélectivement l'engrenage annulaire (108R) du quatrième ensemble d'engrenages planétaires (108) à l'engrenage solaire (102S) du premier ensemble d'engrenages planétaires (102) et à l'engrenage solaire (104S) du deuxième ensemble d'engrenages planétaires (104) ;
20 - un quatrième mécanisme de connexion (126) pour connecter sélectivement le support planétaire (102P) du premier ensemble d'engrenages planétaires (102) à l'engrenage annulaire (108R) du quatrième ensemble d'engrenages planétaires (108) ;
- un premier mécanisme de verrouillage (128) pour verrouiller sélectivement l'engrenage annulaire (108R) du quatrième ensemble d'engrenages planétaires (108) sur le boîtier de transmission (160) ;
25 - un deuxième mécanisme de verrouillage (130) pour verrouiller sélectivement l'engrenage solaire (106S) du troisième ensemble d'engrenages planétaires (106) et l'engrenage solaire (108S) du quatrième ensemble d'engrenages planétaires (108) sur le boîtier de transmission (160) ; et
- un troisième mécanisme de verrouillage (132) pour verrouiller sélectivement l'engrenage annulaire (104R) du deuxième ensemble d'engrenages planétaires (104) sur le boîtier de transmission (160), le rapport de transmission stationnaire de chacun des premier (102), deuxième, (104), troisième (106) et quatrième ensembles d'engrenages planétaires (108) étant négatif.
- 30
- 35 **2.** Agencement de transmission (100) selon la revendication 1, **caractérisé en ce que** l'engrenage annulaire (108R) du quatrième ensemble d'engrenages planétaires (108) est connectable sélectivement au boîtier de transmission (160) via le support planétaire (106P) du troisième ensemble d'engrenages planétaires (106).
- 40 **3.** Agencement de transmission (100) selon l'une quelconque des revendications 1 ou 2, **caractérisé en ce que** l'engrenage solaire (106S) du troisième ensemble d'engrenages planétaires (106) et l'engrenage solaire (108S) du quatrième ensemble d'engrenages planétaires (108) sont connectables sélectivement au boîtier de transmission (160) via le support planétaire (106P) du troisième ensemble d'engrenages planétaires (106).
- 45 **4.** Procédé de commande d'un agencement de transmission (100) selon l'une quelconque des revendications 1 à 3, ce procédé comprenant les étapes suivantes :
- positionnement de trois parmi les mécanismes de verrouillage et de connexion en état engagé ; et
- positionnement de quatre parmi les mécanismes de verrouillage et de connexion en état désengagé.
- 50 **5.** Unité de commande (600) conçue pour commander un agencement de transmission (100) selon l'une quelconque des revendications 1 à 3, l'unité de commande (600) étant conçue pour :
- positionner trois parmi les mécanismes de verrouillage et de connexion en état engagé ; et
- positionner quatre parmi les mécanismes de verrouillage et de connexion en état désengagé.
- 55 **6.** Véhicule comprenant un moteur primaire et une boîte de vitesses, la boîte de vitesse comprenant un agencement de transmission selon l'une quelconque des revendications 1 à 3.

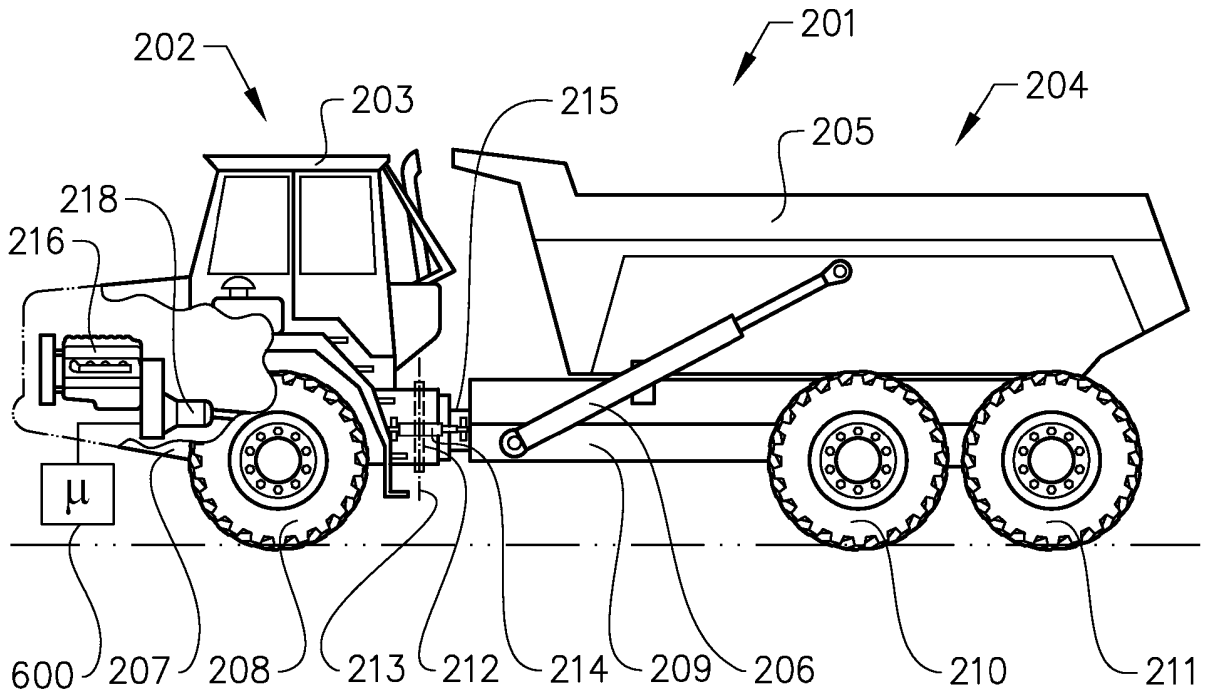

FIG. 1

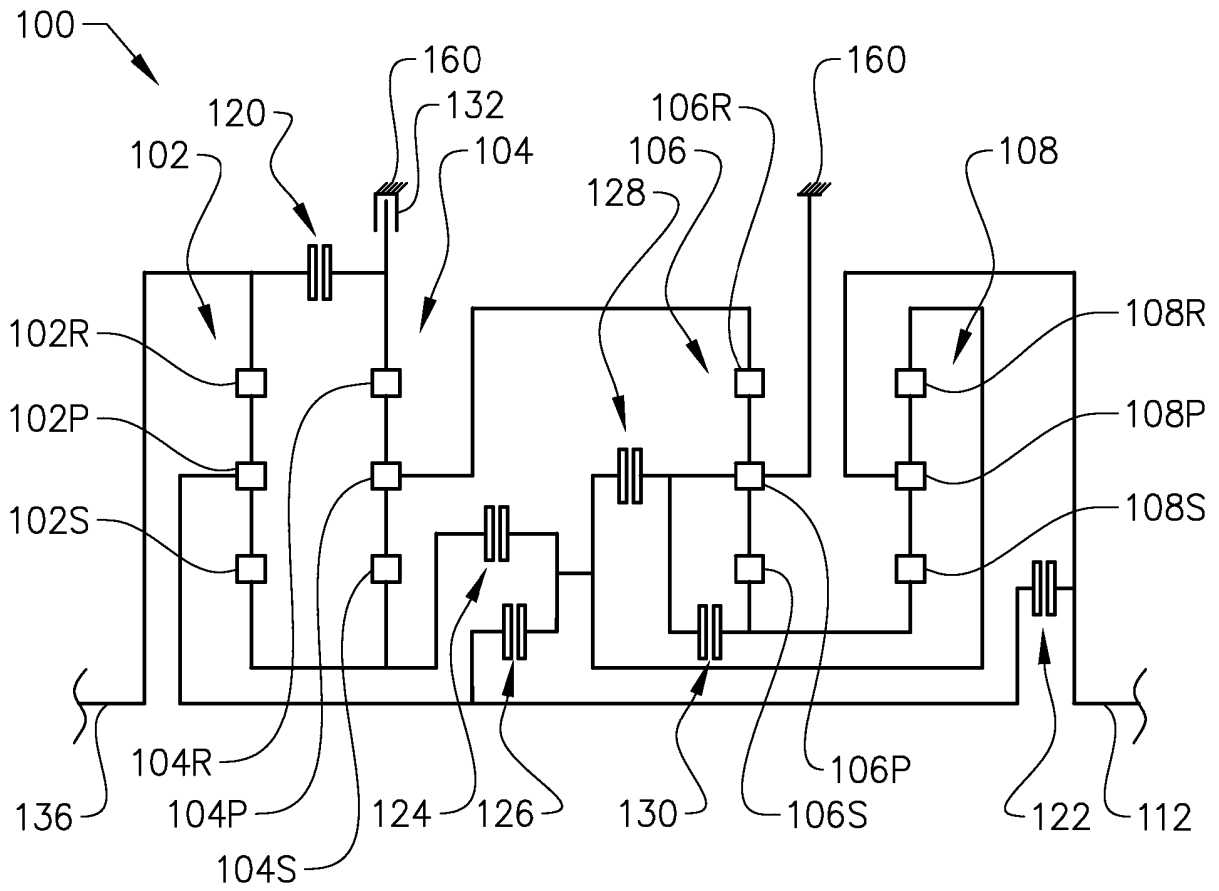

FIG. 2

REFERENCES CITED IN THE DESCRIPTION

This list of references cited by the applicant is for the reader's convenience only. It does not form part of the European patent document. Even though great care has been taken in compiling the references, errors or omissions cannot be excluded and the EPO disclaims all liability in this regard.

Patent documents cited in the description

- US 2008039266 A1 [0004]