



(19) **United States**

(12) **Patent Application Publication**

Lai et al.

(10) **Pub. No.: US 2011/0278260 A1**

(43) **Pub. Date: Nov. 17, 2011**

(54) **INDUCTIVE PLASMA SOURCE WITH METALLIC SHOWER HEAD USING B-FIELD CONCENTRATOR**

C23C 16/00 (2006.01)
H05H 1/24 (2006.01)

(52) **U.S. Cl. 216/68; 156/345.48; 118/723 I; 156/345.33; 427/569**

(75) **Inventors:** **Canfeng Lai**, Fremont, CA (US); **Jeffrey Tobin**, Mountain View, CA (US); **Peter I. Porshnev**, San Jose, CA (US); **Jose Antonio Marin**, San Jose, CA (US)

(73) **Assignee:** **APPLIED MATERIALS, INC.**, Santa Clara, CA (US)

(21) **Appl. No.:** **12/780,531**

(22) **Filed:** **May 14, 2010**

Publication Classification

(51) **Int. Cl.**
H01L 21/306 (2006.01)
C23F 1/00 (2006.01)
B05D 1/00 (2006.01)

(57) **ABSTRACT**

A method and apparatus for plasma processing of substrates is provided. A processing chamber has a substrate support and a lid assembly facing the substrate support. The lid assembly has a plasma source that comprises an inductive coil disposed within a conductive plate, which may comprise nested conductive rings. The inductive coil is substantially coplanar with the conductive plate, and insulated therefrom by an insulator that fits within a channel formed in the conductive plate, or nests within the conductive rings. A field concentrator is provided around the inductive coil, and insulated therefrom by isolators. The plasma source is supported from a conductive support plate. A gas distributor supplies gas to the chamber through a central opening of the support plate and plasma source from a conduit disposed through the conductive plate.

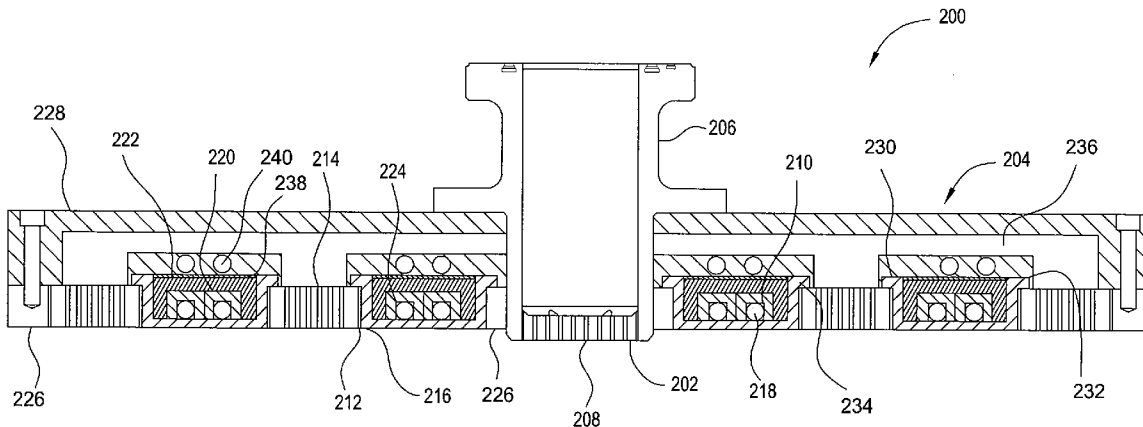

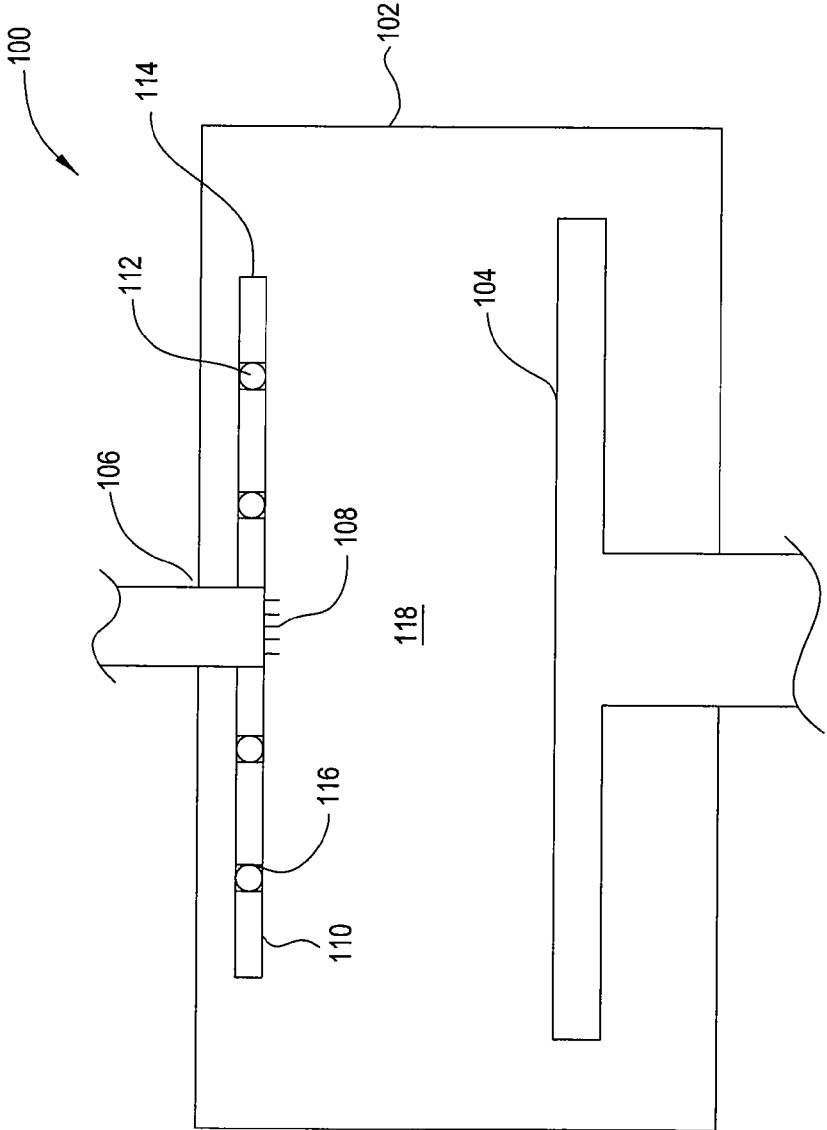

FIG. 1

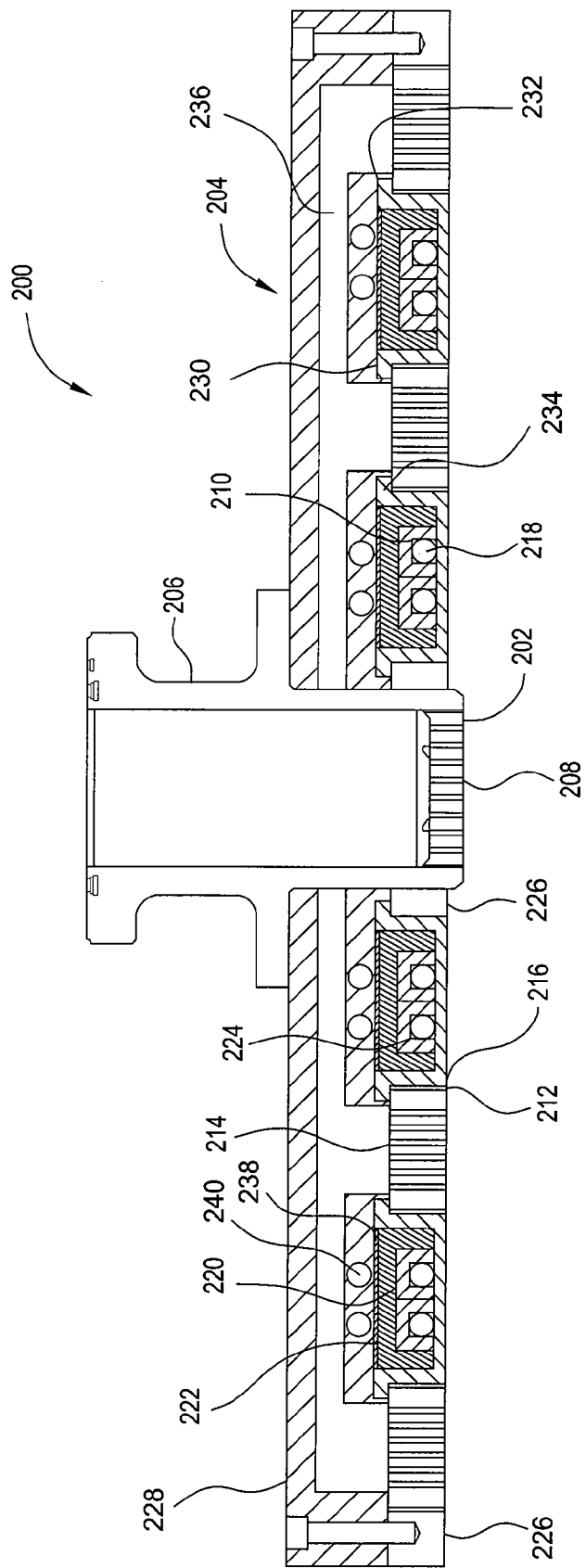

FIG. 2

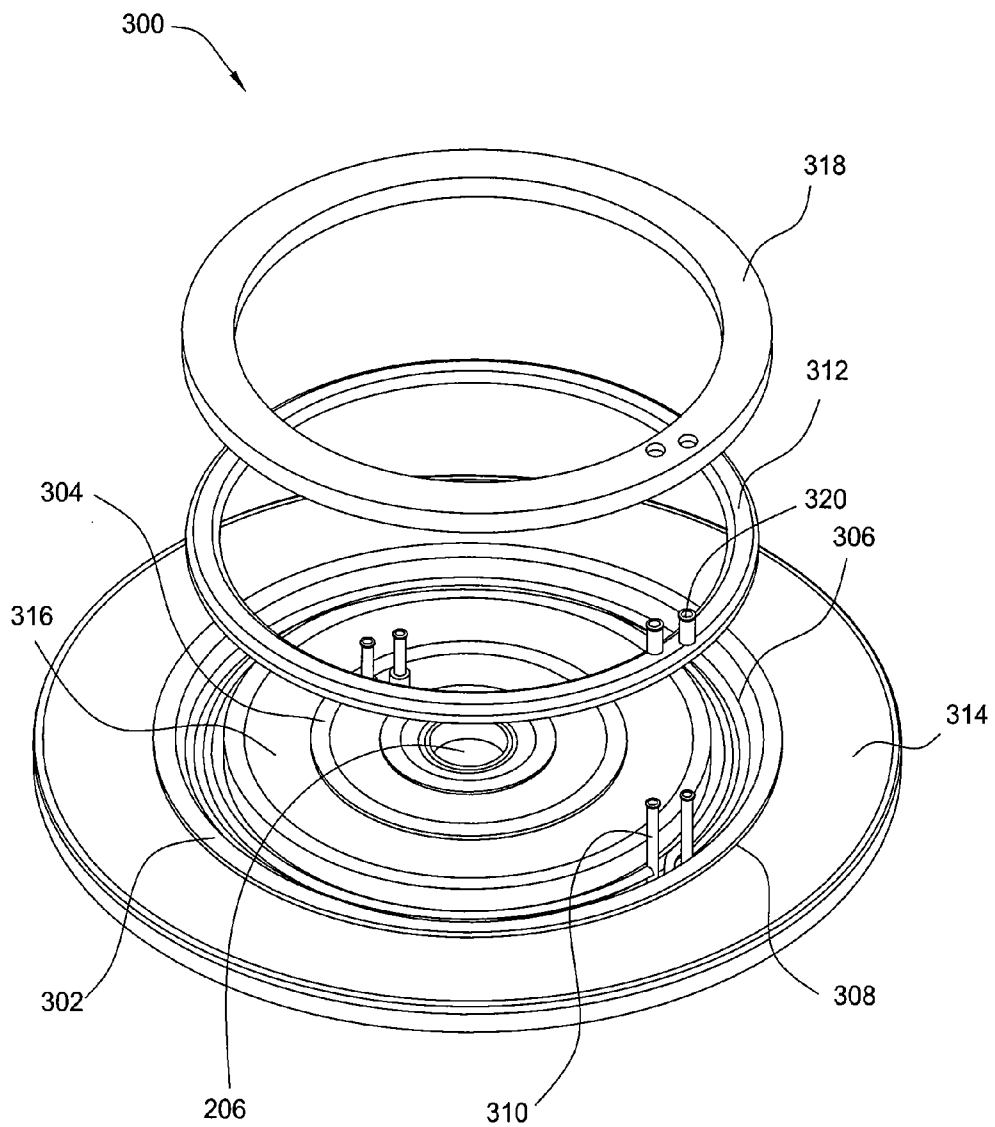

FIG. 3

INDUCTIVE PLASMA SOURCE WITH METALLIC SHOWER HEAD USING B-FIELD CONCENTRATOR

FIELD

[0001] Embodiments described herein generally relate to manufacturing semiconductor devices. More specifically, embodiments described herein relate to methods and apparatus for plasma processing of substrates.

BACKGROUND

[0002] Plasma processing is commonly used for many semiconductor fabrication processes for manufacturing integrated circuits, flat-panel displays, magnetic media, and other devices. A plasma, or ionized gas, is generated inside a processing chamber by application of an electromagnetic field to a low-pressure gas in the chamber, and then applied to a workpiece to accomplish a process such as deposition, etching, or implantation. The plasma may also be generated outside the chamber and then directed into the chamber under pressure to increase the ratio of radicals to ions in the plasma for processes needing such treatments.

[0003] Plasma may be generated by electric fields, by magnetic fields, or by electromagnetic fields. Plasma generated by an electric field normally uses spaced-apart electrodes to generate the electric field in the space occupied by the gas. The electric field ionizes the gas, and the resulting ions and electrons move toward one electrode or the other under the influence of the electric field. The electric field can impart very high energies to ions impinging on the workpiece, which can sputter material from the workpiece, damaging the workpiece and creating potentially contaminating particles in the chamber. Additionally, the high potentials accompanying such plasmas may create unwanted electrical discharges and parasitic currents.

[0004] Inductively coupled plasmas are used in many circumstances to avoid some effects of capacitively coupled plasmas. An inductive coil is disposed adjacent to a plasma generating region of a processing chamber. The inductive coil projects a magnetic field into the chamber to ionize a gas inside the chamber. The inductive coil is frequently located outside the chamber, projecting the magnetic field into the chamber through a dielectric window. The inductive coil is frequently driven by high-frequency electromagnetic energy, which suffers power losses that rise faster than the voltage applied to the inductive coil. Thus, strong coupling of the plasma source with the plasma inside the chamber decreases power losses. Control of plasma uniformity is also improved by strong coupling between the plasma source and the plasma.

[0005] As device geometry in the various semiconductor industries continues to decline, process uniformity in general and plasma uniformity in particular, becomes increasingly helpful for reliable manufacture of devices. Thus, there is a continuing need for inductive plasma processing apparatus and methods.

SUMMARY

[0006] Embodiments described herein provide a lid assembly for a plasma chamber, the lid assembly having a first annular inductive coil nested with a first conductive ring.

[0007] Other embodiments provide a processing chamber for a semiconductor substrate, the processing chamber having

a chamber body that defines an interior region, a substrate support disposed in the interior region, and a lid assembly disposed in the interior region facing the substrate support, the lid assembly having a gas distributor and a plasma source with a first conductive surface that faces the substrate support, a second conductive surface that faces away from the substrate support, and a plurality of conductive coils disposed in the conductive plasma source between the first surface and the second surface.

[0008] Other embodiments provide a method of processing a substrate by disposing the substrate on a substrate support in a processing chamber, providing a plasma source facing the substrate support, the plasma source comprising a plurality of conductive loops disposed in an electrode, to define a processing region between the plasma source and the substrate support, providing a gas mixture to the processing region, grounding the electrode, and forming a plasma from the gas mixture by applying electric power to the conductive loops.

BRIEF DESCRIPTION OF THE DRAWINGS

[0009] So that the manner in which the above recited features of the present invention can be understood in detail, a more particular description of the invention, briefly summarized above, may be had by reference to embodiments, some of which are illustrated in the appended drawings. It is to be noted, however, that the appended drawings illustrate only typical embodiments of this invention and are therefore not to be considered limiting of its scope, for the invention may admit to other equally effective embodiments.

[0010] FIG. 1 is a schematic cross-sectional view of a processing chamber according to one embodiment.

[0011] FIG. 2 is a schematic cross-sectional view of a gas distributor according to another embodiment.

[0012] FIG. 3 is an exploded view of a gas distributor according to another embodiment.

DETAILED DESCRIPTION

[0013] FIG. 1 is a schematic cross-sectional diagram of a processing chamber **100** according to one embodiment. The processing chamber **100** comprises a chamber body **102**, a substrate support **104**, and a gas distributor **106** facing the substrate support **104**, which cooperatively define a processing region **118**. The gas distributor **106** comprises a shower-head **108** and a plasma source **110** surrounding the shower-head **108**. The plasma source **110** comprises a conductive spacer **114** and a conductive coil **112** disposed inside the conductive spacer **114**. There may be one or more conductive coils **112** disposed in the conductive spacer **114**. The conductive spacer **114** may be a disk-like member with channels or conduits housing the conductive coils **112**. Alternately, the conductive spacer **114** may be a plurality of rings separating the conductive coils **112** and nesting with the conductive coils **112**. Each of the conductive coils **112** is housed in a channel or recess **116** lined with an insulating material. The insulating material of the channel or recess **116** prevents electric current travelling from the conductive coils **112** into the conductive spacer **114**. The conductive coils **112** produce a magnetic field in the processing region **118** that ionizes a processing gas disposed therein to form a plasma. In some embodiments, the conductive coil **112** may be a coil assembly featuring a removable insulating member, as further described below in connection with FIG. 2.

[0014] The conductive spacer 114 provides a large surface area grounded electrode that faces the substrate support 104. The large grounded electrode allows generation of higher voltages at the substrate support using lower power levels. Disposing the conductive coils 112 in the conductive spacer 114 also brings the plasma source close to the plasma generation area of the processing region 118, improving coupling efficiency with the plasma. Additionally, the large grounded surface area of the conductive spacer 114 reduces plasma sheath voltage in the chamber, which reduces sputtering of chamber walls and chamber lid components, reducing contamination of workpieces disposed on the substrate support. Use of multiple conductive coils 112 also provides the possibility of using different power levels on the coils to tune the plasma profile in the processing region 118.

[0015] FIG. 2 is a schematic cross-sectional diagram of a lid assembly 200 according to another embodiment. Similar to the gas distributor 106 of FIG. 1, the lid assembly 200 comprises a showerhead 202 and a plasma source 204. A gas conduit 206 connects a gas source (not shown) to the showerhead 202, placing the gas source in fluid communication with a processing chamber through openings 208 in the showerhead 202.

[0016] The plasma source 204 comprises a conductive coil 210 disposed in a channel 212 formed between conductive gas distribution members 214. The gas distribution members 214 may be metal or metal alloy, and may be coated with a dielectric material, if desired, or a chemically resistant or plasma resistant material, such as yttria, in some embodiments. The conductive coil 210, of which there may be more than one, may also be metal, metal alloy, or a conductive composite such as a metal coated dielectric or a metal composite featuring metals having different conductivities. Material selection for the conductive coil 210 generally depends on the desired thermal and electrical conductivity. Materials with lower electrical conductivity are generally lower in cost, but a conductive coil made from low conductivity materials may generate unwanted heat, and may require excessive power to operate. Highly conductive materials such as copper and silver may be used proficiently for a conductive coil. Less conductive and lower cost materials such as aluminum, zinc, or nickel may be included as alloy or layer components.

[0017] Heat may be dissipated by forming the conductive coil 210 with a conduit for a thermal control medium, which may be a cooling liquid such as water or a cooling gas such as nitrogen. The conductive coil 210 may be an annular or toroidal tube in some embodiments. The tube wall thickness may be specified based on thermal and electrical conductivity needed. Cooling may be useful when high power, for example greater than about 500 W, is to be applied to the conductive coil 210. In one embodiment, a conductive coil is a toroidal tube comprising a layer of copper and a layer of silver.

[0018] The channel 212 is generally lined with an insulating member 216, which may be ceramic or plastic, Teflon, for example. The insulating member 216 confines the electric current to the conductive coil 210. The insulating material may be an insert that fits into the channel 212, or in other embodiments, may be a liner adhered to the inner surface of the channel 212. The embodiment of FIG. 2 features two insulating members 216, each of which is an annular member that fits inside a respective channel, one of the insulating members 216 fitting inside the innermost channel 212, which is a first channel in the embodiment of FIG. 2, and the other insulating member 216 fitting inside the outermost channel

212, which is a second channel in the embodiment of FIG. 2. Each of the channels 212 has a conductive coil 210 disposed therein. In the embodiment of FIG. 2, each conductive coil comprises two conductive loops 218. A pair of conductive loops 218 rest inside the recesses formed by the respective insulating members 216.

[0019] The two conductive loops 218 are electrically isolated, one from the other, by respective isolators 220, which serve to surround each conductive loop 218. In the embodiment of FIG. 2, each isolator 220 is an annular dielectric member having a recess 224 into which a conductive loop 218 fits. The recess 224 of an isolator 220 and the channel 212 into which the isolator 220 fits generally face in opposite directions. Thus, each conductive loop is surrounded on three sides by an isolator 220 and on one side by an insulating member 216. It should be noted that the isolators 220 may have any convenient cross sectional shape. For example, in an alternate embodiment, the isolators 220 may be rounded to follow the contours of a rounded, tube-like, conductive loop 218, such that the recess 224 has a rounded cross-sectional shape. In another embodiment, the cross-sectional profile of each isolator 220 and/or each recess 224 may be rectangular with beveled corners. In still other embodiments, the conductive loops 218 may be formed with a coating that isolates the loop. The isolators 220 may be any insulating material, such as ceramic, glass, or plastic. In the embodiment of FIG. 2, each isolator 220 is shown as a single piece covering a single conductive loop 218, but in alternate embodiments, an isolator may be formed to cover two neighboring conductive loops 218 while disposing a wall between them.

[0020] A field concentrator 222 is disposed around each conductive coil 210 to amplify the magnetic field produced by each conductive coil 210. In the embodiment of FIG. 2, the concentrator 222 is disposed around a pair of conductive loops 218 and their respective isolators 220, but in other embodiments, each loop 218 may be paired with a field concentrator 222, or more than two loops may be coupled to a field concentrator 222. The field concentrator 222 focuses the magnetic field produced by each conductive coil 210 toward the plasma generation area of the processing chamber, minimizing magnetic energy projecting away from the plasma generation area. Each field concentrator 222 generally comprises ferrite or other magnetically susceptible or magnetizable materials, such as low coercivity materials. Thermal control of the conductive coil 210 minimizes temperature variation of the field concentrator 222, maintaining the magnetic properties thereof for control of the magnetic field produced by the conductive coil 210.

[0021] The inductive coils 210 are interposed within the gas distribution members 214 that nest with the insulating members 216 and cooperatively define the channels 212. Conductive members 226 may also be interposed with the inductive coils 210 and the gas distribution members 214. In one embodiment, the conductive members 226 are rings that comprise metal, metal alloy, or metal mixtures, each of which may be attached to a support member 228. The insulating members 216 fit between the conductive members 226 and the gas distribution members 214 to provide the channel 212 in a substantially coplanar configuration with the conductive members 214 and 226, such that the inductive coils 210 are substantially coplanar with the conductive members 214 and 226.

[0022] The support member 228 is generally also conductive. In some embodiments, the support member 228 is a

metal block. The support member 228 has recesses 230 that, together with the conductive members 226, define capture spaces 232 into which respective shoulder portions 234 of each insulating member 216 are captured to secure the insulating members 216 into the lid assembly 200. The conductive members 214 and 226 allow for a large grounded surface to be brought into close proximity to the plasma, enabling higher bias voltage to be used on the substrate support at lower power levels and lower heat input (FIG. 1). The lid assembly configuration of FIG. 2 also brings the plasma source energy of the inductive coils 210 into close proximity with gas in the processing region, resulting in higher plasma density at lower power levels. Use of multiple inductive coils such as the inductive coils 210 also enables tuning of the plasma profile generated in the chamber by adjusting the power level applied to each individual coil.

[0023] The support member 228 comprises one or more conduits 236 that bring process gases to the conductive gas distribution members 214. Additionally, in some embodiments, the conductive gas distribution members 214 may comprise conduits (not shown) to disperse gas from the conduit 236 around the circumference of the gas distribution member 214 for even gas distribution. By interposing conductive gas distribution members 214 with inductive coils 210, the apparatus 200 may be used as both a plasma source and a showerhead. Gas flow is distributed evenly across the face of the apparatus, and RF power is close-coupled to the process gas exiting the various openings.

[0024] Thermal control may be enhanced by optionally including thermal control conduits 240 in the support member 228. Locating thermal control conduits in the support member 228 may enhance thermal control of the field concentrators 222, which are otherwise at least partially insulated from any thermal control fluid circulating through the loops 218 by the isolators 220. Thermal control in the vicinity of the field concentrators 222 may be advantageous for maintaining electromagnetic properties of the field concentrators 222. Also optionally, a cushion 238 may be disposed between the field concentrators 222 and the support member 228 to avoid any damage to the field concentrators 222, which may be easily damaged by direct contact with the metal surface of the support member 228. The cushion 238 may be a thermally conductive material such as Grafoil®, which is a flexible graphitic sealing material manufactured by Natural Graphite Operations, of Lakewood, Ohio, a subsidiary of GrafTech International, and distributed by Leader Global Technologies, of Deer Park, Tex.

[0025] In general, the lid assembly 200 may have any convenient shape or size for processing substrates of any dimension. The lid assembly 200 may be circular, rectangular, or any polygonal shape. The lid assembly 200 may be of a size and shape adapted for processing semiconductor wafers for making semiconductor chips of any description, or the lid assembly 200 may be of a size and shape adapted for processing semiconductor panels such as large-area display or solar panels. Other types of substrates, such as LED substrates or magnetic media substrates, may also be processed using a lid assembly as herein described. In some embodiments, the conductive coil (or coils) 210 may be disposed in a concentric circular shape, in a concentric non-circular (rectangular, polygonal, square, or irregular) shape, or in a non-concentric shape such as a boustrophedonic or zig-zag pattern. In another non-concentric embodiment, the conductive coil (or coils) 210 may be disposed in a spiral pattern.

[0026] In some embodiments, a lid assembly may be similar to the lid assembly 200 of FIG. 2, with some differences. In one embodiment, the lid assembly may have a curved surface facing the substrate support, curved in a convex or concave sense. In one aspect, the entire plasma source may be curved (i.e. the surface of the plasma source facing the substrate support and the surface facing away from the substrate support are both convex or concave). In another aspect, only the surface of the lid assembly facing the substrate support may be curved. In one embodiment, multiple showerheads may be provided, especially for large area lid assemblies. In one embodiment, gas may be injected through the conductive members 226 by providing one or more conduits through the support member 228. In other embodiments, conductive coils may be provided that comprise a single electrical circuit, rather than multiple discrete circuits. For example, in one embodiment, the conductive coil may be arranged in a planar, circular or rectangular spiral shape nested with, or disposed in, a complementary conductive member such that the conductive member and the conductive coil form a substantially planar plasma source. Such a spiral shape may also be z-displaced such that the plasma source is not planar, but has a z-dimension in a convex or concave sense.

[0027] FIG. 3 is an exploded view of a lid assembly 300 according to another embodiment. The lid assembly 300 is similar in most respects to the lid assembly 200 of FIG. 2, and identical features are labeled with the same identifying labels. The lid assembly 300 comprises a conduit 206 for delivering gas to the process region of the chamber on which the lid assembly 300 is installed. The lid assembly 300 further comprises a first RF coil 302 and a second RF coil 304 similar to the first RF coil, with the first RF coil 302 shown in exploded format. The first RF coil 302 comprises a plurality of conductors 306 disposed in an insulating channel 308. In the embodiment of FIG. 3, the conductors 306 are circular and concentric, but in alternate embodiments the conductors 306 may be disposed in any convenient configuration, as described herein. Each of the conductors 306 has a contact 310 for supplying power to the conductor 306. As described elsewhere herein, the conductors 306 may be conductive tubes configured to carry a coolant in addition to electric power. Thus, the contacts 310 may also be used to provide coolant to the conductors 306.

[0028] The conductors 306 are generally metal, or other electrically conductive material. The metal may be a single metal, an alloy, a mixture, or another combination of metals. The conductors 306 may also be coated with a non-conductive material, such as ceramic or polymer, in some embodiments. In one embodiment, the conductors 306 are copper tubes plated with silver. The metals to be used generally depend on the electrical and thermal properties needed for the particular embodiment. In high power applications, higher electrical conductivity will generally result in lower thermal budget, so more conductive materials may be advantageous. It should be noted that when multiple RF coils are used, each of the coils may have a different composition. For example, silver plated copper tubes may have different thicknesses of silver plating or different tube wall thicknesses to provide differential conductivity among the tubes. In other embodiments, each RF coil may have only one conductor, or more than two conductors.

[0029] An insulator 312 is disposed over the conductors 306 so that the conductors 306 are surrounded by insulative material. This prevents electric power from flowing to the

conductive rings **314** and **316** interposed between the first and second RF coils **302** and **304**. The insulator **312** comprises a wall that is not visible in the top-perspective view of FIG. 3. The wall extends between the two conductors **306** to prevent electrical cross-talk between the conductors **306** in a given RF coil **302** or **304**. Thus, each conductor **306** is surrounded by insulative material. When power is provided to the conductors **306**, a magnetic field is generated by the conductors **306**. A field concentrator **318** is disposed partially around the conductors **306** to focus and direct the magnetic field in the direction of the processing zone for improved efficiency.

[0030] The insulator **312** further comprises a passage **320** for each contact **310**. The passages **320** pass through openings in the field concentrator **318** to provide a pathway for the contacts **310** to be coupled to electric power while preventing electrical contact between the contacts **310** and the field concentrator **318**. The contacts protrude through the field concentrator **318**, where they may be coupled to an RF source.

[0031] As with the embodiment of FIG. 2, any number of RF coils may be disposed in the lid assembly **300**. Process gases may also be provided through the conductive rings **314** and **316**, in addition to or in place of the conduit **206**, by providing conduits in the conductive rings **314** and **316** with openings to release process gases into the processing zone. The lid assembly **300** may also be formed with a curvature according to any of the embodiments described herein.

[0032] Embodiments disclosed herein also provide a method of processing a substrate on a substrate support in a process chamber. A plasma source may be provided in a position facing the substrate support to form a plasma for processing the substrate. The method comprises providing a plasma source that has a plurality of conductive loops disposed in an electrode, providing a processing gas to the chamber, grounding the electrode, and forming a plasma from the processing gas by applying power to the conductive loops. The conductive loops may be electrically insulated from the electrode by coating, wrapping, or situating the loops in an electrically insulating material, which may be a container, such as a channel formed in the electrode, a coating applied to the conductive loops, or a liner disposed inside a channel formed in the electrode. RF power is applied to the loops, and may be controlled independently to shape the plasma density in the process chamber. The conductive loops may be thermally controlled, if desired, by circulating a thermal control medium, such as a cooling fluid, through tubular conductive loops.

[0033] The conductive loops may be substantially coplanar with the electrode in some embodiments. In other embodiments, the electrode may be non-planar, with conductive loops disposed therein. In still other embodiments, the conductive loops may be partially disposed in the electrode and partially disposed outside the electrode, with any portions of the conductive loops disposed outside the electrode contained or encapsulated in an insulating material.

[0034] The plasma may be further enhanced by providing a field concentrator disposed to concentrate the field inside the plasma region of the processing chamber. For example, the field concentrator may generally be disposed opposite the substrate support, such that the conductive loops are between the field concentrator and the substrate support. Such positioning prevents development of magnetic field lines outside the chamber, and focuses the plasma source energy in the processing gas.

[0035] While the foregoing is directed to embodiments of the present invention, other and further embodiments of the invention may be devised without departing from the basic scope thereof, and the scope thereof is determined by the claims that follow.

1. A lid assembly for a plasma chamber, comprising: a first annular inductive coil nested with a first conductive ring.
2. The lid assembly of claim 1, wherein the first annular inductive coil is disposed in an insulating channel nested with the first conductive ring.
3. The lid assembly of claim 2, further comprising a field concentrator disposed around the first annular inductive coil inside the insulating channel.
4. The lid assembly of claim 3, further comprising a second annular inductive coil disposed in a second insulating channel nested with the first conductive ring.
5. The lid assembly of claim 4, wherein the first and second annular inductive coils and the first conductive ring are arranged concentrically.
6. The lid assembly of claim 4, wherein the first and second annular inductive coils each comprise a metal tube.
7. The lid assembly of claim 6, wherein the first annular inductive coil is nested in a central opening of the conductive ring and the second annular inductive coil is nested about a peripheral edge of the conductive ring.
8. A lid assembly for a plasma chamber, comprising: a gas distributor; a support plate disposed around the gas distributor; a conductive ring disposed around the gas distributor and coupled to the support plate; an annular inductive coil disposed in an insulating channel nested with the conductive ring; and a field concentrator disposed in the insulating channel around the inductive coil.
9. The lid assembly of claim 8, wherein the insulating channel is concentrically disposed in a central opening of the conductive ring, has an opening that faces the support plate, and has an extension over an inner edge of the conductive ring.
10. The lid assembly of claim 9, wherein the support plate is conductive and is electrically coupled to the conductive ring.
11. The lid assembly of claim 8, wherein the gas distributor is coupled to a conduit through a central aperture of the support plate, the conductive ring, and the annular inductive coil, the support plate is electrically coupled to the conductive ring, the annular conductive coil is electrically insulated from the support plate and the conductive ring, and the annular conductive coil is substantially coplanar with the conductive ring.
12. The lid assembly of claim 8, further comprising an isolator disposed in the insulating channel, the isolator having a channel into which the annular inductive coil fits.
13. The lid assembly of claim 12, wherein the annular inductive coil is substantially coplanar with the conductive ring.
14. The lid assembly of claim 13, wherein the annular inductive coil comprises a conduit for a thermal control medium.
15. A processing chamber for a semiconductor substrate, comprising:

a chamber body defining an interior region;
a substrate support disposed in the interior region; and
a lid assembly disposed in the interior region facing the substrate support, the lid assembly comprising:
a gas distributor; and
a plasma source having a first conductive surface that faces the substrate support, a second conductive surface that faces away from the substrate support, and a plurality of conductive coils disposed in the conductive plasma source between the first surface and the second surface.

16. The processing chamber of claim **15**, wherein each the conductive coils is disposed in a conduit formed in the conductive plasma source, and the conduit is lined with an insulating material.

17. The processing chamber of claim **16**, wherein a magnetic field concentrator is disposed within the conduit.

18. The processing chamber of claim **17**, wherein each conductive coil is formed with an internal pathway for a thermal control medium.

19. The processing chamber of claim **18**, wherein each conductive coil comprises a plurality of conductive loops separated by insulators.

20. A method of processing a substrate, comprising:
disposing the substrate on a substrate support in a processing chamber;
providing a plasma source facing the substrate support, the plasma source comprising a plurality of conductive loops disposed in an electrode, to define a processing region between the plasma source and the substrate support;
providing a gas mixture to the processing region;
grounding the electrode; and
forming a plasma from the gas mixture by applying electric power to the conductive loops.

21. The method of claim **20**, further comprising tuning the plasma profile by applying different power levels to the conductive loops.

22. The method of claim **21**, further comprising circulating a cooling medium through the conductive loops.

23. The method of claim **22**, wherein the gas mixture is provided to the processing region through an aperture in a central portion of the plasma source.

24. The method of claim **22**, wherein the gas mixture is provided to the processing region through a plurality of apertures in the plasma source.

* * * * *