

H. E. WAITE.  
ROTARY MARKING STAMP.

(Application filed Oct. 21, 1899.)

(No Model.)

3 Sheets—Sheet 1.

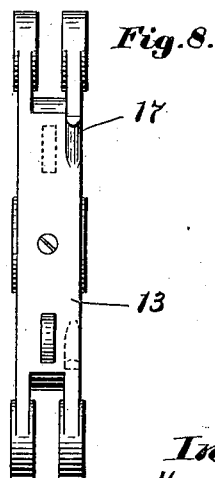
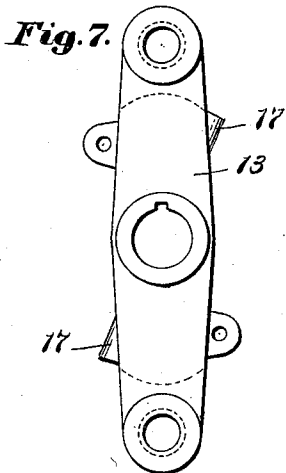
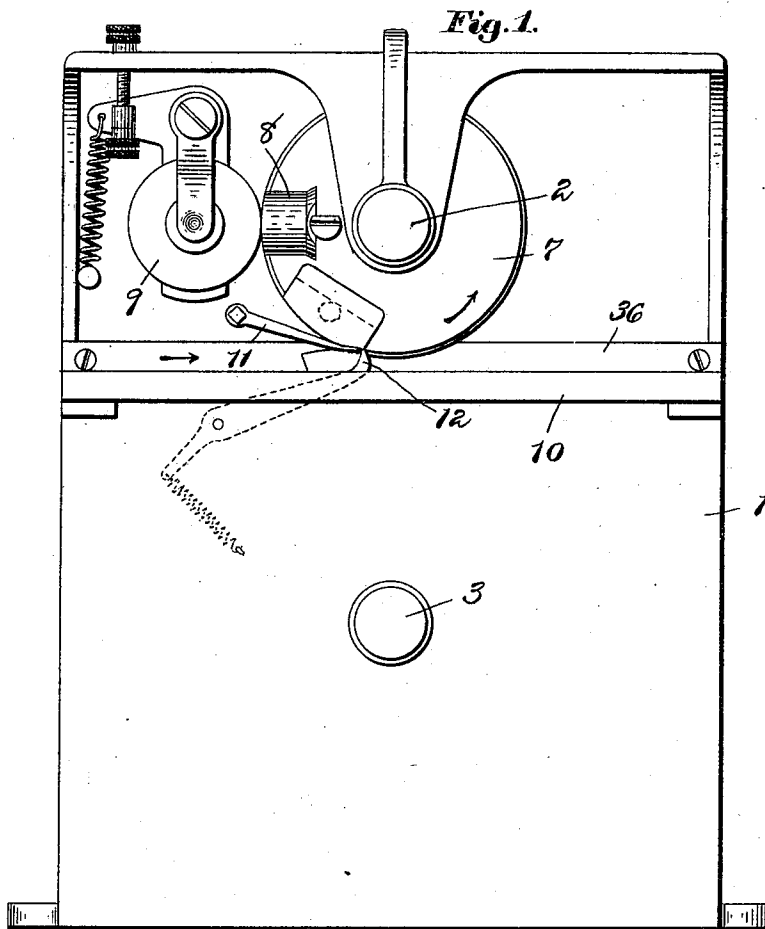

Witnesses:  
 Charles F. Logan.  
 A. W. Pizzetti.

Inventor:  
 Henry E. Waite  
 by Wright Brown & Lundy  
 Atty's.

H. E. WAITE.  
ROTARY MARKING STAMP.

(Application filed Oct. 21, 1899.)

(No Model.)

3 Sheets—Sheet 2.

Fig. 2.

Fig. 3.

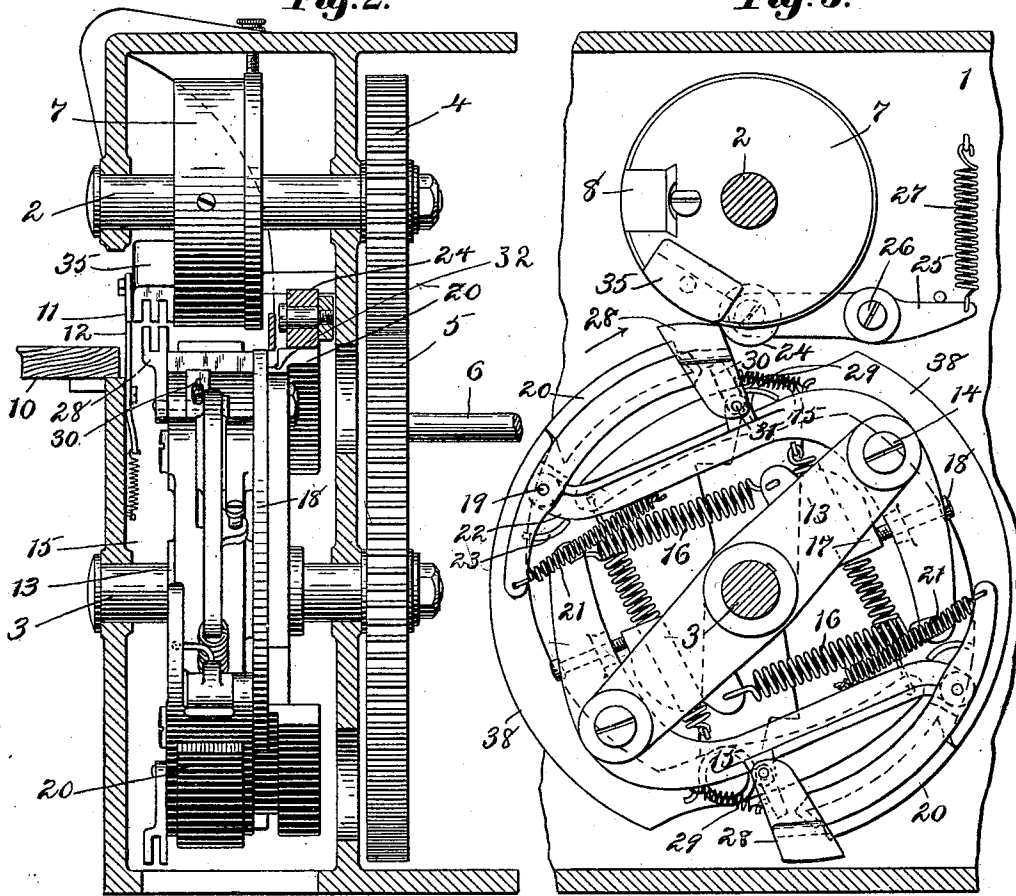
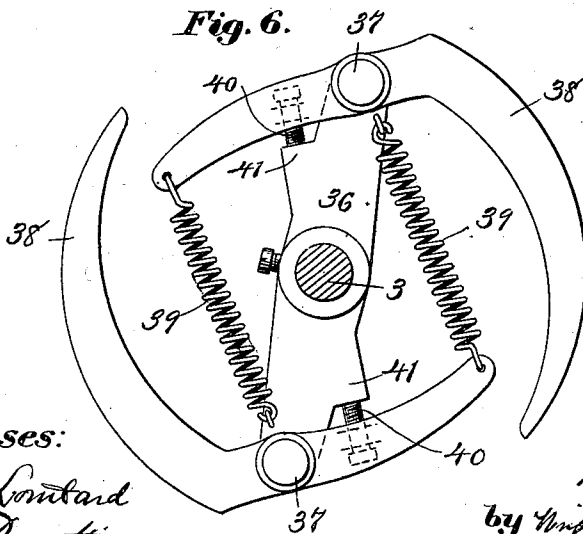

Fig. 6.



Witnesses:

Walter C. Lombard  
P. H. Dazzetti

Inventor:

Henry E. Waite  
by Wright, Brown & Samsby  
Attys.

H. E. WAITE.  
ROTARY MARKING STAMP.

(Application filed Oct. 21, 1899.)

(No Model.)

3 Sheets—Sheet 3.

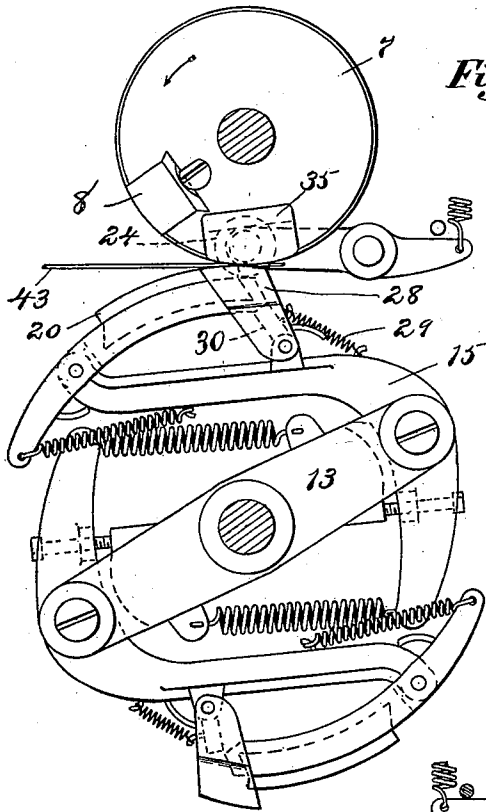

Fig. 4.

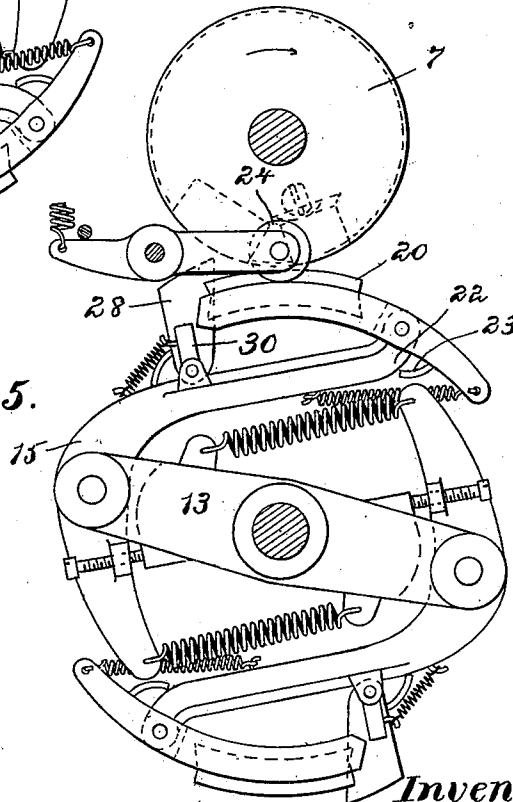

Fig. 5.

Witnesses:  
*P. J. Szyzeto*  
*H. L. Robbins*

Inventor:  
*Henry E. Waite*  
by *Wright, Brown & Lundy*  
Attys:

# UNITED STATES PATENT OFFICE.

HENRY E. WAITE, OF NEWTON, MASSACHUSETTS.

## ROTARY MARKING-STAMP.

SPECIFICATION forming part of Letters Patent No. 646,198, dated March 27, 1900.

Application filed October 21, 1899. Serial No. 734,299. (No model.)

*To all whom it may concern:*

Be it known that I, HENRY E. WAITE, of Newton, in the county of Middlesex and State of Massachusetts, have invented certain new and useful Improvements in Rotary Marking-Stamps, of which the following is a specification.

This invention relates to rotary marking-stamps for use in banks, post-offices, or other offices in marking mail-matter, checks, and matter of a similar nature; and it has for its object to provide a simple and inexpensive construction and to secure a smooth and comparatively-noiseless operation.

With these ends in view the invention consists in certain novel features of construction and arrangement, which I shall now proceed to describe and claim.

Of the accompanying drawings, forming a part of this specification, Figure 1 represents a front elevation of a mail-marking device constructed in accordance with my invention. Fig. 2 represents a vertical section through the shafts, showing the working parts in end elevation. Fig. 3 represents a detail front elevation of the printing-wheels. Fig. 4 represents a similar detail view showing the relation of parts when a letter is present. Fig. 5 represents a reverse plan view of the same parts, showing their relation when no letter is present. Fig. 6 represents a front elevation of the segmental carrying devices. Figs. 7 and 8 represent detail elevations of a part hereinafter referred to.

The same reference characters indicate the same parts in all the figures.

Referring to the drawings, Figs. 1 to 3 are particularly illustrative of a hand-operated device. In said figures, 1 designates a frame having bearings for two shafts 2 3, mounted on opposite sides of the letter-path and having on their ends intermeshing spur-gears 4 5, the latter of which is of twice the diameter and number of teeth of the former and is provided with a handle 6, whereby the shafts may be rotated. On the upper shaft 2 is secured a marking-disk 7, having a printing-die 8 suitably secured to it, said die being inked in every revolution by means of an ink-roll 9. Upon the lower shaft 3 is secured the impression-wheel, which I shall presently describe.

10 is a horizontal table secured to the frame 1 opposite the path between the marking and impression rolls and adapted to support the letters, which are faced and fed into the device by hand.

12 is a yielding stop which forms a V, with a fixed stop 11 in the letter-path, said stop 12 being adapted to arrest the letters until engaged between the printing members.

The impression-wheel is preferably, though not necessarily, a compound one, being provided with two impression-pads to coact with the marking-die 8 in marking letters, said impression-roll having one revolution to every two of the die by reason of the relation of the gears 4 5.

13 is a support or hub (shown in detail in Figs. 7 and 8) secured to the shaft 3 and having at its ends studs 14, on which are pivoted two levers 15 15. The heels of said levers are attached to heavy springs 16 16, which normally project the opposite ends of the levers outwardly, the object of these springs being only to allow the impression-pads to yield for thick letters. The outward movement of the ends of the levers carrying the impression-pads is limited by means of adjustable screw-stops 18 on the levers coacting with fixed stops 17 on the hub 13. Each lever 15 carries an impression-pad 20, pivotally connected with it at 19, the acting surface of said pad being preferably composed of a yielding material. The pad 20 is yieldingly projected to the periphery of the impression-wheel in a position to coact with the marking-die by means of a light spring 21, attached to its heel. The outward movement of the pad is limited by means of a stop or abutment 23 on its heel coacting with an abutment 22 on the lever 15.

It is necessary in order that the pads 20 shall not be inked by the printing-die when no letter is present to displace them from their normal positions by a device which is operative only when no letter is present. Such a device is shown in the form of a roll 24, which I term a "rejector," mounted on the end of a lever 25, pivotally attached at 26 to the frame 1 and projected by a spring 27 in the direction of the pads. The spring 27 is a heavier one or one of greater force than the spring 21 holding the pad, but of consider-

ably-less force than the spring 16, holding the lever 15. The roll 24 engages the edge of the pad-frame behind or to the side of the letter-path, as indicated in Fig. 2. The edge of the letter when positioned between the rolls abuts against a longitudinal strip 36, placed behind the printing-die and the operative portion of the pad, and the pad-frame is recessed at 32 to accommodate this strip. It is evident, by reason of the described relative tensions of the several springs, that the pad 20 when not obstructed or locked will be displaced in each revolution by the rejector 24, thereby avoiding a deposit of ink on the platen when no letter is interposed.

Letter-controlled means are provided for locking the impression-pad 20 with relation to its supporting-arm 15 when a letter is present, said means being constructed as follows:

28 is a letter-engaging trip pivoted at 31 to the lever 15 and having its free end yieldingly held by the action of a spring 29 beyond the normal periphery of the impression-wheel.

35 is a coacting abutment attached to the marking-disk 7 and adapted to engage the opposite side of the letter from the trip 28. Said trip and abutment are arranged to pass or lap each other when they come into conjunction, no letter being present, and to this end and to give them considerable lateral bearing-surface the tread or bearing surface of both trip and abutment may, as shown in Fig. 2, be formed of a number of longitudinal plates or webs separated by grooves or spaces, the arrangement being such that the webs of one member enter the grooves of the other when no letter is present. A letter when present, however, covers the grooves and causes the free end of the trip 28 to be pressed inwardly.

30 is a small locking-dog pivoted at 31 to the lever 15 on the same hinge-line with the trip 28 and attached to said trip, so that the two oscillate together. The spring 29 is attached to said dog 30 and the lever 15. The end of the dog 30 is located in proximity to the free end of the pad 20, but is normally out of the path of movement of the letter when no letter is present. When the trip 28 is pressed inwardly by the presence of a letter, the end of the dog 30 moves into line with the end of the pad 20, and their relation is then such that the dog locks the pad and prevents its inward movement with respect to the lever 15. The letter will then be marked by reason of the pressure between the pad 20 and the die 8, measured by the heavy spring 16. The latter, as stated, is adapted to yield to accommodate letters of different thicknesses. The trip 28 and the abutment 35 act as grippers, which grip the letter and start it past the stop 12. When the trip engages a letter and is oscillated on its pivot, there is a certain amount of backward movement of the tread end of the trip relatively to the letter

and to the abutment 35, owing to the relation of the parts.

38 38 represent two segmental carrying members pivotally secured at 37 37 to a support or hub 36, secured to the shaft 3 alongside of the support 13. Heavy springs 39 39, secured to the heels of the levers 38 and to the support 36, normally project the segmental ends of said levers outwardly, the outward movement thereof being limited by means of screw-stops 40, secured to the levers and abutting against stops 41 on the support 36. The segmental portions of the levers 38 correspond to the general contour of the impression-wheel, and their free ends are so located as to form continuations of the pads 20, the object of said carrying-levers being to continue the carrying-surfaces formed by the pads, so as to continue to propel the letter in conjunction with the edge of the marking-disk 7 after the pads have passed out of engagement with the letter. It will be noted that the tension of the springs 29 is such that the locking-dogs 30 are normally thrown out of locking position. This tension remains while the dogs are in locking engagement with the pads; but the frictional pressure of the pads against the dogs is sufficient to hold the latter in locking position after the trip 28 has passed from engagement with a letter as long as the pad continues in such engagement.

The operation is as follows: Letters are placed one at a time in the throat between the stops 11 12 and are pressed forward by one hand of the operator while he drives the device by means of the handle 6 with the other hand. The die and one of the pads coming into coacting position will engage and advance the letter, at the same time marking it, the pad having been locked by the engagement of the trip 28 with the face of the letter just previous to the coaction of the printing members. The letter continues to be propelled without further assistance from the operator's hand, and after being marked may be allowed to fall into or upon a suitable receptacle.

My invention is not limited to hand-operated machines.

I claim—

1. In a rotary marking-stamp, a printing-couple comprising a revolving marker and a revolving impression-pad, one of which is movable toward and from its center of revolution and yieldingly projected away therefrom so as to assume printing relation with the other member, a fixed support, a rejector yieldingly mounted on said support and engaging the said yielding printing member in each revolution of the latter, and displacing the same from printing relation with the other member when the yielding member is unlocked, and letter-controlled means revolving with the yielding member for locking the letter in printing position when a letter is present.
2. In a rotary marking-stamp, a printing-

couple comprising a revolving marker and a revolving impression-pad, one of which is movable toward and from its center of revolution and yieldingly projected away therefrom so as to assume printing relation with the other member, a fixed support, a spring-held lever pivoted thereon and carrying a roller adapted to engage the said yielding printing member in each revolution of the latter and displace the same from printing relation with the other member when the yielding member is unlocked, and letter-controlled means revolving with the yielding member for locking the latter in printing position when a letter is present.

3. In a rotary marking-stamp, a printing-couple comprising a revolving marker and a revolving impression-pad, one of which is movable toward and from its center of revolution and yieldingly projected away therefrom so as to assume printing relation with the other member, a rejector engaging said yielding printing member in each revolution of the latter and displacing the same from printing position when the yielding member is not locked, a letter-controlled lock revolving with said yielding member and adapted to lock the latter in printing position when a letter is present, and yielding means normally retracting said lock or holding it out of locking position.

4. In a rotary marking-stamp, a printing-couple comprising a revolving marker and a revolving impression-pad, one of which is movable toward and from its center of revolution and yieldingly projected away therefrom so as to assume printing relation with the other member, a rejector engaging said yielding printing member in each revolution of the latter and displacing the same from printing position when the yielding member is not locked, a letter-controlled lock revolving with said yielding member and adapted to lock the latter in printing position when a letter is present, and a letter-engaging trip positively connected with said lock and adapted to carry the latter into locking position.

5. In a rotary marking-stamp, a printing-couple comprising a revolving marker and a revolving impression-pad, one of which is movable toward and from its center of revolution and yieldingly projected away therefrom so as to assume printing relation with the other member, a rejector engaging said yielding printing member in each revolution of the latter and displacing the same from printing position when the yielding member is not locked, a pivoted lock revolving with said yielding member, a letter-engaged trip secured to said lock and oscillating on the same pivot therewith and adapted to carry said lock into position to lock the yielding member in printing position when a letter is present, and yielding means normally retracting said lock or holding it out of locking position.

6. In a rotary marking-stamp, a revolving support, a member of a printing-couple pivotally mounted on said support eccentrically to the axis of revolution thereof, means for oscillating said member inwardly toward said axis out of printing position when no letter is present, and a letter-controlled lock adapted to support the free end of the member and hold said member in printing position when a letter is present.

7. In a rotary marking-stamp, two revolving supports held in fixed bearings on opposite sides of the letter-path, a lever pivotally mounted on one of said supports eccentrically to the axis of revolution thereof, a member of a printing-couple mounted on one end of said lever, a cooperating member mounted on the other support, and a spring connected with said lever and normally projecting outwardly the end which carries the first said member.

8. In a rotary marking-stamp, a revolving support held in fixed bearings, a lever pivotally mounted on said support eccentrically to the axis of revolution thereof, a spring yieldingly projecting one end of said lever outwardly, a member of a printing-couple pivoted to said end, a second spring of less force than the first spring normally holding the said member in printing position, means for displacing said member from printing position when no letter is present, and letter-controlled means for locking said member with respect to the lever when a letter is present.

9. In a rotary marking-stamp, a revolving support held in fixed bearings, a segmental member of a printing-couple yieldingly mounted thereon, and a segmental carrying member yieldingly mounted on said support and forming a continuation of the carrying-surface of the first-said member and adapted to advance the letter after the first-said member has passed from engagement therewith.

10. In a rotary marking-stamp, two revolving supports held in fixed bearings on opposite sides of the letter-path, a lever pivotally mounted on one of said supports eccentrically to the axis of revolution thereof, a member of a printing-couple mounted on one end of said lever, a cooperating member mounted on the other support, a spring connected to said lever and normally projecting outwardly the end which carries the first-said member, and a segmental carrying member yieldingly mounted on the first-said support and forming a continuation of the carrying-surface of the first-said member.

11. In a rotary marking-stamp, a revolving support, a member of a printing-couple yieldingly mounted on said support, an opposed revolving support carrying a cooperating member, a lock adapted to lock the first-said printing member in position and carried by its support, a letter-engaging trip carried by said support and controlling said lock, and an abutment mounted on the opposed support and adapted to engage the opposite side of

the letter from said trip, whereby the trip is operated.

12. In a rotary marking-stamp, a revolving support, a member of a printing-couple yield-  
5 ingly mounted on said support, an opposed revolving support carrying a cooperating member, a lock adapted to lock the first-said member in printing position and carried by its support, a yielding stop adapted to arrest  
10 the letters, cooperating gripping members carried by the respective supports and located

in advance of the printing members, said gripping members engaging the letter and advancing it past said stop, the gripping member on the support which carries the lock acting as  
15 a letter-engaged trip which controls said lock.

In testimony whereof I have affixed my signature in presence of two witnesses.

HENRY E. WAITE.

Witnesses:

R. M. PIERSON,  
P. W. PEZZETTI.