

(19) World Intellectual Property Organization
International Bureau



(43) International Publication Date
22 December 2011 (22.12.2011)

(10) International Publication Number
WO 2011/156865 A1

(51) International Patent Classification:
E02F 3/88 (2006.01) *E02F 9/14* (2006.01)

(21) International Application Number:
PCT/AU2011/000731

(22) International Filing Date:
17 June 2011 (17.06.2011)

(25) Filing Language: English

(26) Publication Language: English

(30) Priority Data:
2010902669 18 June 2010 (18.06.2010) AU

(71) Applicants (for all designated States except US): **NAUTILUS MINERALS PACIFIC PTY LTD** [AU/AU]; Level 7, 303 Coronation Drive, Milton, Queensland 4064 (AU). **SOIL MACHINE DYNAMICS LTD** [GB/GB]; Turbinia Works, Davy Bank, Wallsend Tyne and Wear NE28 6UZ (GB).

303 Coronation Drive, Milton, Queensland 4064 (AU). **JAFFERS, Daal Hallam** [AU/AU]; c/o Level 7, 303 Coronation Drive, Milton, Queensland 4064 (AU). **RIDLEY, Nicholas William** [GB/GB]; c/o Turbinia Works, Davy Bank, Wallsend Tyne and Wear NE28 6UZ (GB).

(74) Agent: **MONKS IP**; PO Box 164, Blackheath, New South Wales 2785 (AU).

(81) Designated States (unless otherwise indicated, for every kind of national protection available): AE, AG, AL, AM, AO, AT, AU, AZ, BA, BB, BG, BH, BR, BW, BY, BZ, CA, CH, CL, CN, CO, CR, CU, CZ, DE, DK, DM, DO, DZ, EC, EE, EG, ES, FI, GB, GD, GE, GH, GM, GT, HN, HR, HU, ID, IL, IN, IS, JP, KE, KG, KM, KN, KP, KR, KZ, LA, LC, LK, LR, LS, LT, LU, LY, MA, MD, ME, MG, MK, MN, MW, MX, MY, MZ, NA, NG, NI, NO, NZ, OM, PE, PG, PH, PL, PT, RO, RS, RU, SC, SD, SE, SG, SK, SL, SM, ST, SV, SY, TH, TJ, TM, TN, TR, TT, TZ, UA, UG, US, UZ, VC, VN, ZA, ZM, ZW.

(72) Inventors; and
(75) Inventors/Applicants (for US only): **JONES, Glen Robert** [AU/AU]; c/o Level 7, 303 Coronation Drive, Milton, Queensland 4064 (AU). **INGLIS, Antony Eliot** [NZ/GB]; c/o Level 7, 303 Coronation Drive, Milton, QLD, AU 4064 (GB). **O'SULLIVAN, Anthony Paul** [AU/AU]; c/o Level 7, 303 Coronation Drive, Milton, Queensland 4064 (AU). **HOWITT, Michael** [AU/AU]; c/o Level 7, 303 Coronation Drive, Milton, Queensland 4064 (AU). **SMITH, Glen Martindale** [AU/AU]; c/o Level 7, 303 Coronation Drive, Milton, Queensland 4064 (AU). **BERNDT, Roland Gunter** [ZA/AU]; c/o Level 7,

(84) Designated States (unless otherwise indicated, for every kind of regional protection available): ARIPO (BW, GH, GM, KE, LR, LS, MW, MZ, NA, SD, SL, SZ, TZ, UG, ZM, ZW), Eurasian (AM, AZ, BY, KG, KZ, MD, RU, TJ, TM), European (AL, AT, BE, BG, CH, CY, CZ, DE, DK, EE, ES, FI, FR, GB, GR, HR, HU, IE, IS, IT, LT, LU, LV, MC, MK, MT, NL, NO, PL, PT, RO, RS, SE, SI, SK, SM, TR), OAPI (BF, BJ, CF, CG, CI, CM, GA, GN, GQ, GW, ML, MR, NE, SN, TD, TG).

[Continued on next page]

(54) Title: METHOD AND APPARATUS FOR AUXILIARY SEAFLOOR MINING

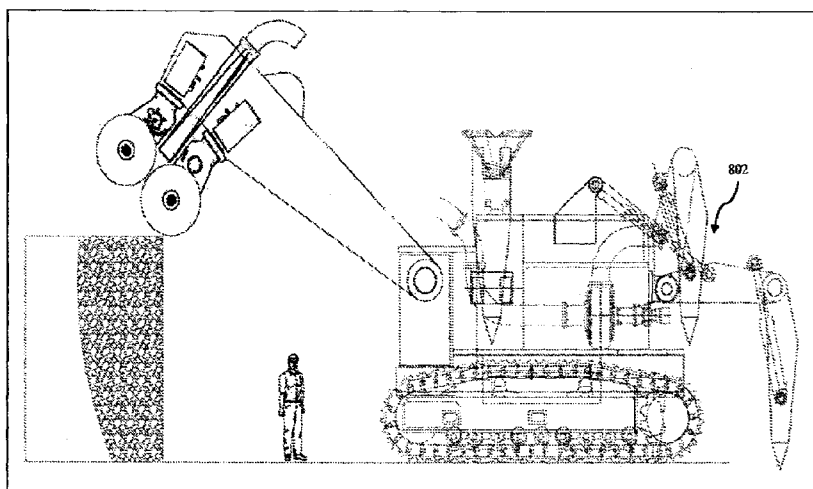

Figure 8

(57) Abstract: A seafloor auxiliary mining tool for use in a seafloor mining system. The seafloor auxiliary mining tool has a seafloor locomotion system enabling traversal of the seafloor. Umbilical connections receive power and control signals from a surface source. A boom mounted auxiliary cutting tool is configured to cut extremities of a seafloor deposit. Cuttings produced by the auxiliary cutting tool are sized by sizing means, to ensure such cuttings are no greater than a desired size.

WO 2011/156865 A1

Published:

— with international search report (Art. 21(3))

METHOD AND APPARATUS FOR AUXILARY SEAFLOOR MINING

Technical Field

The present invention relates generally to underwater mining, and in particular relates
5 to a tool for carrying out seafloor mining in cooperation with other seafloor tools.

Background of the Invention

Seabed excavation is often performed by dredging, for example to retrieve valuable
alluvial placer deposits or to keep waterways navigable. Suction dredging involves
10 positioning a gathering end of a pipe or tube close to the seabed material to be
excavated, and using a surface pump to generate a negative differential pressure to suck
water and nearby mobile seafloor sediment up the pipe. Cutter suction dredging further
provides a cutter head at or near the suction inlet to release compacted soils, gravels or
even hard rock, to be sucked up the tube. Large cutter suction dredges can apply tens
15 of thousands of kilowatts of cutting power. Other seabed dredging techniques include
auger suction, jet lift, air lift and bucket dredging.

Most dredging equipment typically operates only to depths of tens of metres, with even
very large dredges having maximum dredging depths of little more than one hundred
20 metres. Dredging is thus usually limited to relatively shallow water.

Subsea boreholes such as oil wells can operate in deeper water of up to several
thousand metres depth. However, subsea borehole mining technology does not enable
seafloor mining.

25

Any discussion of documents, acts, materials, devices, articles or the like which has
been included in the present specification is solely for the purpose of providing a
context for the present invention. It is not to be taken as an admission that any or all of
these matters form part of the prior art base or were common general knowledge in the
30 field relevant to the present invention as it existed before the priority date of each claim
of this application.

Throughout this specification the word "comprise", or variations such as "comprises" or "comprising", will be understood to imply the inclusion of a stated element, integer or step, or group of elements, integers or steps, but not the exclusion of any other element,
5 integer or step, or group of elements, integers or steps.

Summary of the Invention

According to a first broad aspect the present invention provides a seafloor auxiliary mining tool for use in a seafloor mining system, the seafloor auxiliary mining tool
10 comprising:

- a seafloor locomotion system enabling traversal of the seafloor;
- umbilical connections for receiving power and control signals from a surface source;
- a boom mounted auxiliary cutting tool for cutting extremities of a seafloor
15 deposit; and
- means for sizing cuttings produced by the auxiliary cutting tool to ensure such cuttings are no greater than a desired size.

According to a second aspect the present invention provides a method for seafloor
20 auxiliary mining in a seafloor mining system, the method comprising:

- a seafloor auxiliary mining tool traversing the seafloor using a seafloor locomotion system;
- the tool receiving power and control signals from a surface source via umbilical connections;
- 25 a boom mounted auxiliary cutting tool cutting extremities of a seafloor deposit; and
- a sizing means of the tool sizing cuttings produced by the auxiliary cutting tool to ensure such cuttings are no greater than a desired size.

30 The means for sizing cuttings may comprise at least one pair of cutting heads which form the auxiliary cutting tool, the cutting heads being configured to preferentially

draw cuttings between the pair of cutting heads, and the pair of cutting heads being spaced apart by a distance corresponding to the desired cutting size. In such embodiments, cuttings larger than the desired cutting size which are drawn between the pair of cutting heads will be further cut and/or crushed to be less than the desired cutting size. The spacing between the or each pair of cutting heads can be fixed at a predetermined spacing, for example depending on the ore being mined and the size of particles needing to be extracted. Alternatively, the spacing between the or each pair of cutting heads may in some embodiments be adjustable during mining operations. Alternatively, the means for sizing cuttings may comprise a sizing grill proximal to the auxiliary cutting tool, for example positioned above the cutting head between the head and the boom, and/or aft of the cutting head. Alternatively, the means for sizing cuttings may comprise other suitable sizing devices whether fixed or adjustable. The pair of cutting heads are preferably counter-rotating so as to draw cuttings between the cutting heads to effect sizing of the cuttings.

15

By providing the auxiliary mining tool with an auxiliary cutting tool, and leaving bulk mining for a separate seafloor tool, the present invention provides for a relatively agile seafloor cutting tool which has enhanced mobility enabling operation in seafloor regions of complex topography and which can flexibly perform an array of cutting tasks. The auxiliary cutting tool can thus be used in preparation for bulk mining to cut down peripheries of complex seafloor formations in order to present relatively flat and horizontal benches suitable for a separate bulk mining tool. The present invention thus provides an auxiliary tool operable to function in cooperation with other seafloor mining tools to effect retrieval of the seafloor material, even when presented with a complex seafloor topography, while able to function alone when presented with complex seafloor topography. At some sites the agility of the auxiliary mining tool may be such that other tools may not be required to effect retrieval of the seafloor material.

30 The seafloor auxiliary mining tool is capable of traversing uneven ground and slopes, such capability being affected by the seafloor locomotion system. The seafloor

locomotion system may comprise any suitable locomotion elements, for example wheels, continuous tracks, legs, or the like. The locomotion system preferably enables the auxiliary mining tool to traverse seafloor terrain sloped up to about 10 degrees, more preferably up to about 20 degrees and even more preferably up to about 25
5 degrees.

The auxiliary mining tool in preferred embodiments is operable to work a seafloor site to prepare a bench for bulk mining. The auxiliary mining tool in preferred embodiments is further operable to work remnant edges left by a bulk miner. The
10 boom for mounting the auxiliary cutting tool preferably comprises an hydraulically operated articulated arm. In one form, the boom may be mounted on an upper carriage assembly capable of slewing relative to the auxiliary mining tool centre line.

In some embodiments of the invention, the seafloor auxiliary mining tool may comprise
15 a detachable winch cable attachment point, allowing the tool to be winched between the seafloor and the surface, and to detach from the winch cable and self-propel once on the seabed.

Further, the present invention provides a seafloor auxiliary mining tool adaptable in
20 some embodiments to deployment at significant water depths. For example some embodiments may be operable at depths greater than about 400m, more preferably greater than 1000m and more preferably greater than 1500m depth. Nevertheless it is to be appreciated that the auxiliary mining tool of the present invention may also present a useful seafloor mining option in water as shallow as about 100m or other
25 relatively shallow submerged applications. Accordingly it is to be appreciated that references to the seafloor or seabed are not intended to exclude application of the present invention to mining or excavation of lake floors, estuary floors, fjord floors, sound floors, bay floors, harbour floors or the like, whether in salt, brackish, or fresh water, and such applications are included within the scope of the present specification.

In embodiments of the invention deployed to seafloor sites of complex topography, the seafloor auxiliary mining tool is preferably employed to initiate site excavation. For example the seafloor auxiliary mining tool may prepare a landing area for other seafloor tools, and may excavate extremities of the site in order to prepare a first bench
5 ready for bulk mining.

A preferred embodiment of the invention further includes a suction delivery line having an inlet adjacent to the auxiliary cutting tool and an outlet spaced from the auxiliary mining tool. In preferred embodiments of the invention, the auxiliary mining tool
10 comprises a slurry pump system and a slurry inlet proximal to the cutting head(s), configured to capture cuttings in the form of a slurry. The slurry may be pumped a short distance from the seafloor auxiliary mining tool, for example simply to one side of the path taken or to be taken by the tool. Alternatively, the slurry may be pumped to a seafloor stockpile location some distance away from the seafloor auxiliary mining
15 tool via a suitable transfer pipe. The slurry inlet, or suction inlet, may be positioned just aft of the cutting head. In embodiments comprising two or more cutting heads, the or each suction inlet may be positioned between cutting heads.

In preferred embodiments, a collection shroud partially surrounds the cutting head(s) to
20 optimise containment and collection of cuttings by the slurry pump system. The seafloor auxiliary mining tool preferably comprises a blade to help keep cuttings ahead of the vehicle, and also preferably configured to shroud the cutting tool by maintaining cuttings near the cutting head and assist reworking of oversized cuttings. The blade is preferably arcuately shaped so as to effect substantially equal shrouding at differing
25 slew positions of the cutting tool. The blade preferably assists a suction inlet of the tool in clearing cuttings produced by the cutting heads. The blade is also preferably configured to clear the path ahead of the auxiliary mining tool by acting as a push blade as the machine traverses forwards.

30 The seafloor auxiliary mining tool may be an untethered remotely operated vehicle (ROV) or may be a tethered vehicle operated by umbilicals connecting to the surface.

The seafloor auxiliary mining tool preferably clears its own cuttings to the spaced outlet at a dump site to enable the seafloor auxiliary mining tool to progress through a formation as it works. For example the auxiliary mining tool may pump its cuttings in
5 slurry form to a position lateral to the tool's path of travel.

The seafloor auxiliary mining tool's weight is preferably selected in order to apply the forces required for the auxiliary mining tasks. In order to further stabilise the auxiliary mining tool, movable anchoring spuds may be provided.

10

The bench may comprise an ore bench of valuable ore to be retrieved, or may comprise a bench of hard rock, or other seafloor material to be removed for other purposes. The ore may comprise seafloor massive sulphides.

15 In an alternative embodiment of the system, the auxiliary miner is configured with slurry transfer pipes which are arranged to deliver cuttings from the tool in a slurry form to a stockpile site distal from the cutting location of the tool.

Brief Description of the Drawings

20 An example of the invention will now be described with reference to the accompanying drawings, in which:

Figure 1 is a simplified overview of a subsea system incorporating an auxiliary mining tool in accordance with a preferred embodiment of the present invention;

25 Figure 2 is a side view of an auxiliary mining tool in accordance with one embodiment of the present invention;

Figure 3 illustrates the cutting and suction process of the auxiliary mining tool of Fig. 2;

Figure 4 depicts the overall auxiliary mining tool system;

30 Figure 5 is a perspective view of the boom-mounted cutting head of the auxiliary mining tool; and

Figure 6 is a cross sectional view of the boom-mounted cutting head of the auxiliary mining tool in operation.

Figure 7a depicts the auxiliary mining tool performing site preparation;

Figure 7b depicts the auxiliary mining tool trimming remnant edges of an ore
5 bench;

Figure 8 depicts a further embodiment of the auxiliary mining tool with a moveable anchoring / stabilising spud system;

Figures 9a-9d illustrate an auxiliary cutter in accordance with another embodiment of the invention; and

10 Figures 10a and 10b illustrate an auxiliary cutter in accordance with a further embodiment of the invention.

Description of the Preferred Embodiments

Figure 1 is a simplified overview of a subsea system 100, which incorporates an
15 auxiliary mining tool (AUX) 116 in accordance with an embodiment of the present invention. A derrick 102 and dewatering plant 104 are mounted upon an oceangoing production support vessel (PSV) 106. The PSV 106 has ore transfer facilities to load retrieved ore onto barge 108. The present embodiment provides a tool 116 operable to
20 to about 2500m depth, however alternative embodiments may be designed for operation to about 3000m depth or greater. During production operations, seafloor mining tools (SMTs) will be used to excavate ore from the seabed 110. The SMTs comprise a seafloor bulk miner 112, a seafloor gathering machine (GM) 114 and a seafloor auxiliary mining machine 116 and a stockpiling system 124. The bulk miner (BM) 112 and gatherer 114 may be of any suitable form. In this embodiment ore mined by the
25 auxiliary mining machine 116 and bulk mining machine 112 is gathered and pumped by each respective machine in the form of a slurry to a stockpile system 124, for example through stockpile transfer pipe 126 (shown interrupted in Figure 1 for clarity).

The stockpiled ore is gathered and pumped, in the form of slurry, through a riser
30 transfer pipe (RTP) 120 to a subsea lift pump 118, which then lifts the slurry via a rigid riser 122 (shown interrupted in Figure 1, and may be up to about 2500m long in this embodiment). The slurry travels to the surface support vessel 106 where it is dewatered by plant 104. The waste water is returned under pressure back to the seafloor to provide charge pressure for the subsea lift pump 118. The dewatered ore is offloaded

onto transport barge 108 to be transported to a stockpile facility before being transported to a processing site.

The seafloor auxiliary mining tool 116 of this embodiment is provided for cutting and if / as required pumping material away from a work face location. The seafloor auxiliary mining tool 116 is a remote operated vehicle, capable of operating to a water depth of about 2500m, and is operated from on board the PSV 106. Operation of the seafloor auxiliary mining tool 116 is controlled subject to ore grade, over-all production rate and operational and maintenance constraints. Excavated particle size is controlled by the auxiliary mining tool 116 cutter type, cutter rotation speed, speed of advancement of the cutter heads, depth of cut, cutter pick spacing and angle and cutter head spacing.

Bulk mining and gathering can then be carried out by any suitable means.

15

While the auxiliary mining tool 116 may be utilised in any suitable mining process, in the embodiment shown in Figure 1 the ore recovery sequence is as follows. First, any unconsolidated sediment is removed using the gathering machine (GM), and deposited in a pre defined area that may or may not form part of the mine. Then, obstructions are cut down using the AUX 116 of this embodiment, to prepare a level landing area for the BM 112 and GM 114. This site preparation by the auxiliary mining machine 116 is illustrated in Figure 7a.

Next, ore left by the auxiliary mining tool 116 is gathered with the GM 114. Benches are cut using the BM 112 then cut and sized ore is gathered using GM 114, this being repeated until remnant edges are about 4 metres high. Then, the remnant edges are trimmed using the AUX 116 of this embodiment, as shown in Figure 7b.

Thus, the AUX 116 initiates seafloor mining operations and prepares an adequate landing area for other seafloor tools, and if required for other seafloor devices such as a stockpiling device. The AUX 116 is also used to remove edge sections of ore benches which cannot be accessed or efficiently mined by a bulk miner.

Figure 2 is a side view of auxiliary mining tool 116 in accordance with this embodiment of the present invention. Figure 2 illustrates the size of the AUX 116 of this embodiment, giving insight into its functionality. The AUX 116 pumps ore

utilising a slurry dredge pump system 202, to a seafloor stock pile area, which is then gathered at a later date by suitable seafloor gathering machine (GM) 114. Continuous tracks 204 provide for seafloor locomotion of the tool 116, even over complex seafloor topography. Winch cable attachment point 206 permits detachable attachment of the
5 tool 116 to a winch cable to permit winching of the tool 116 between the surface and the seafloor. Cutting head 210 is mounted on boom 208, permitting use of cutting head 210 in a versatile range of positions, heights, and angles.

Figure 3 illustrates the cutting and suction process of the auxiliary mining tool 116. As
10 can be seen, the AUX 116 is a vehicle with tracks 204 and a cutter suction boom assembly 208, which is articulated and capable of boom slewing of about +/- 40 degrees laterally of the machine centre line and is capable of rising above and below the machine. As seen in Figure 5, cutting head 210 comprises two pairs of counter rotating cutter heads 212 which are electrically or hydraulically driven via umbilical
15 power supply to cut ore and deliver cuttings to an inlet in the form of a centrally located suction head 214 located in between the counter-rotating cutter heads 212. Suction head 214 can be in various shapes and sizes to suit the size and type of material being cut and extracted. Shown in Figure 2, a bucket / blade 216 is also provided to assist with material clearing and add to the effectiveness of the cutters 212. Bucket/blade 216
20 also acts as a shroud for the cutters to aid in the suction removal of the cuttings. A shroud 218 in Figure 2 is also provided to assist in the effectiveness of the suction head 214 in Figure 5 and size the cuttings and control the size of the cuttings.

Tool 116 may further comprise a water jet system (not shown) for high pressure water
25 injection to the cutter head 210, and a slurry / ore suction / delivery line 202, using a suction dredge pump system, to pump cut material and transport it to a subsea stock pile zone via a stockpile hose 126 of Figure 1 and connector system, and stockpile system 124. In another embodiment, an upper carriage assembly 220 in figure 2 provides the capability of slewing the auxiliary mining vehicle's cutting heads. In
30 another embodiment a further assembly (hydraulic cylinder 222) on the cutter heads allows the spacing of the cutter heads to be adjusted during operation to improve cutting efficiency and cuttings extraction efficiency and size the cuttings and control the size of the cuttings.

35 In this embodiment the tool 116 has a dry land weight of approx 200 to 250 tonnes, a cutting power to tool weight ratio suitable for this type of machine, and a number of

- primary functions. The tool 116 removes obstructions and high points and prepares a clear landing area for other tools to commence cutting operations, as shown in Figure 7a. Tool 116 cuts and cleans areas of the bench that are inaccessible to a less agile bulk miner, as shown in Figure 7b. The tool 116 can pump cut material to a seafloor stockpile area, and assist with levelling and grinding up seafloor chimneys. The boom action of the tool 116 enables cutting of bench heights of up to about 4m, even on a slope, and enables the tool 116 to clear bench edges and/or footwall interfaces which are not readily accessible by less agile seafloor tools.
- 5
- 10 The auxiliary mining tool 116 is further operable to perform tidying cuts to clean up the mine site at the completion of mining, and can also cut an access ramp for other seafloor tools to high points of a mine, and/or cut a ramp up to a peak area thus generating its own access way to the peak itself.
- 15 The tool 116 is manoeuvred on the seafloor by means of crawler tracks 204. It is capable of handling rocky ground and rough terrain, and has an ability to both operate and manoeuvre on slopes. The tool 116 can also be lifted and landed to relocate around the site using its main winch wire 402, from the support vessel.
- 20 The AUX 116 is designed to cut and gather ore, pumping it to either a stockpile or to a side cast zone just behind or beside the vehicle. The AUX 116 is designed with a counter rotating cutter head 210 complete with central suction head 214 to cut ore efficiently and if / as required deliver it to a stockpile at a spaced location.
- 25 The cutter/suction head 210 is mounted on an articulated boom 208 capable of slewing, lifting and lowering, and changing the angular position of the cutter suction head 210 in the vertical plane. The forward and aft spacing of the cutter heads can be changed by mechanism 222 to adjust and increase cutting and suction efficiency during operations and size the cuttings and control the size of the cuttings.
- 30
- The overall Auxiliary Mining Machine system is outlined in Figure 4. The Production Support Vessel (PSV) hosts the control room from which the AUX 116 is operated, along with the winches for both the umbilical and the lift wire, and an A frame for deployment and recovery of the AUX 116. The AUX is connected to the vessel by
- 35 means of an umbilical cable 404, and a main hoist wire 402.

The umbilical cable 404 provides electrical power to drive the motors and pumps required to drive the main components of the AUX 116, such as track drive motors, hydraulic system drive motor(s), dredge system pump drive motor(s) and the cutter drive system.

5

The umbilical 404 also provides control lines suitably in the form of multiplexed fibre optic communication links between the AUX 116 and the operational controls on the PSV 106.

10 The AUX 116 is lowered from the PSV 106 to the seafloor, via the main hoist wire 402. When the AUX 116 is landed out on the seafloor, the hoist wire 402 can be disconnected and recovered either back to the PSV 106, or to a safe height whereby it will not get tangled with the umbilical 404 during mining operations.

15 The AUX 116 incorporates systems within the chassis to find, engage, secure and disconnect the stockpile hose connector (also incorporating a coupling, emergency-disconnect system and swivel). If required, a stockpile hose may be stored within the AUX chassis on a stowage arrangement such as a wind-out reel. Once the AUX 116 is on the seafloor, a stockpile hose is connected (if required for stockpile mining
20 operations) and the AUX 116 is then ready for cutting and stockpiling operations.

When the AUX 116 is ready to be recovered to the PSV 106, the hoist wire 402 is reconnected and the stockpile hose disconnected. The cutter boom 208 is slewed to the zero degree, fully extended and lifted position. Tool 116 can then be lifted from the
25 seafloor, and recovered to the PSV 106.

As previously outlined, the AUX incorporates two different methods for ore placement, those being the vehicle rear or side-cast method, and the stockpile transfer method. As shown in Figure 3, control of suitable valves allows slurry from suction head 214 to be
30 selectively directed to either a stockpile hose connector system 302, or a rear / side cast lay down outlet 304. The rear or sidecast method is utilised in areas that are easily, and efficiently accessed by the gathering machine 114 (for subsequent clean up and recovery of the material). The stockpile method is utilised for restricted access areas so as to transfer the ore to a pre-defined stockpile location from which the GM 114 will
35 recover the ore. Appropriate mine planning can define which ore placement method will be adopted for which location.

A dual counter-rotating drum cutter 210 is used for the main cutting head which is outlined in general in Figures 5 and 6. The cutter 210 is mounted on a two function hydraulic boom 208 which is capable of lifting and lowering in the horizontal axis, and
5 slewing around the vertical axis. The boom 208 provides a versatile mounting for the cutter assembly 210 and allows a large volume of rock to be cut without moving the vehicle itself. This versatility allows the arm 208 and cutter 210 to 'target', for example, steps or other discontinuities, such as isolated towers, as may be encountered in the mine. The rock cutter head 210 is of about 600 kW power, on an articulated arm
10 208, which provides a versatile mounting for the cutter and allows large volumes of rock to be cut without moving the auxiliary miner itself.

The boom 208 operates in successive downward/sideward cuts to complete a full sump depth, full width cut of the mine face to an approximate sumping depth around 1 metre.
15 The boom and cutter angle positions can then be adjusted to carry out a further 1 metre sumping depth cut before the vehicle is required to reposition forward.

The excavated material can be drawn away from the work area, through the suction nozzle 214 detailed in figures 5 and 6, by a high flow dredge pump system. The slurry
20 flow circuit is shown in more detail in Figure 3. A dilution system is used to reduce the chances of blockage and control the slurry density in the suction and delivery lines. A densitometer and flow meter is used to constantly monitor the concentration and velocity gradients through the slurry circuit.

The AUX 114 of the further embodiment is a tracked vehicle. Whilst mining, a moveable anchoring system taking the form of stabilising spuds engage and penetrate the seafloor surface layer in order to provide more positive control of the miner, as shown in Figures 7a and 7b. As further shown in figure 8, each movable spud 802 of a vehicle anchoring / stabilising system is independently powered, allowing limited
30 ability to level the vehicle on uneven ground. The spuds are designed to penetrate through any loose surface material to locate into good quality ground. For soft ground, larger area shoes can be fitted to the spuds. The spuds can also each be in the form of a blade. The blade then allows the functionality of a spud and also allows an ability to move material during forward or aft locomotion of the machine.

A jet water system 306 is installed to provide clearance of the suction grizzly 214 in the event of blockage, and agitation of the material face to be cut if required. The jet system 306 can clean the cutter head 210 or tracks 204 in the event of clogging. The jet system may also assist with slurry line blockage prevention/clearance.

5

The AUX 116 can move from one area of the seafloor to another in one of two ways. The AUX 116 is capable of tracking on seafloor topographies of less than about 10 degrees, at rates > about 600 m/hour. Alternatively, the vehicle 116 can be hoisted off the seafloor using the main hoist wire 402, and manoeuvred to the next site.

10

When manoeuvring in the locality, the powerful track assemblies 204 provide for efficient repositioning of the vehicle 116 for maximum operational production capability. The AUX 116 thus provides more efficient cutting and stock-piling of excavated material.

15

Figures 9a -- 9d illustrate an auxiliary cutter 900 in accordance with another embodiment of the invention, comprising a cutting tool support boom 902, front swing-out stabilising legs 904 with vertical jacking, tracks 906 for site traversing, a rear sonar array 908, electronic control pod indicated at 910, a rear stabilising anchor/blade 912, main cutting tools 914, a crown cutter stockpile gathering system 916 mounted to the underside of boom 902, two thrusters 918, a lifting point and capture bowl 922 for 20 degree slope recovery, a stockpile hose interface 924 and a slurry transfer pump and motor 926.

20

Figure 10 illustrates a further embodiment of the invention in which an auxiliary miner 1000 has a blade 1010 to push cuttings ahead of the chassis and minimise or avoid cuttings passing beneath the tool 1000. Blade 1010 is semicircularly curved so that the aft cutting heads remain at a substantially constant distance from the blade when moved azimuthally, as shown in Figure 10b. This arrangement effects improved efficiency of gathering by the suction inlet adjacent the cutting head, as visible in Figure 10b, and also clears stray cuttings from the path of the tool.

25
30

It is to be appreciated that particular terms used herein may be synonymous with other terms which equally describe the present invention and the scope of the present application is thus not to be limited to any one such synonym. For example, seafloor mining tools may also be referred to as subsea machines, a production support vessel
5 may be referred to as a surface vessel and/or surface facilities, ore may be equally or alternatively referred to as rock, consolidated sediment, unconsolidated sediment, soil, seafloor material, and mining may comprise cutting, dredging or otherwise removing material. Moreover, particular values provided give an illustration of scale in the described embodiments but are not to be considered restrictive as to the scale or range
10 of values which might be used in other embodiments to suit the environment of application.

It will be appreciated by persons skilled in the art that numerous variations and/or modifications may be made to the invention as shown in the specific embodiments
15 without departing from the spirit or scope of the invention as broadly described. The present embodiments are, therefore, to be considered in all respects as illustrative and not restrictive.

CLAIMS:

1. A seafloor auxiliary mining tool for use in a seafloor mining system, the seafloor auxiliary mining tool comprising:
 - a seafloor locomotion system enabling traversal of the seafloor;
 - umbilical connections for receiving power and control signals from a surface
 - 5 source;
 - a boom mounted auxiliary cutting tool for cutting extremities of a seafloor deposit; and
 - means for sizing cuttings produced by the auxiliary cutting tool to ensure such cuttings are no greater than a desired size.
- 10 2. The tool of claim 1 wherein the means for sizing cuttings comprises at least one pair of cutting heads which form the auxiliary cutting tool, the cutting heads being configured to preferentially draw cuttings between the pair of cutting heads, and the pair of cutting heads being spaced apart by a distance corresponding to the desired cutting size.
- 15 3. The tool of claim 2 wherein the spacing between the or each pair of cutting heads is fixed at a predetermined spacing.
4. The tool of claim 2 wherein the spacing between the or each pair of cutting heads is adjustable during mining operations.
5. The tool of any one of claims 1 to 4 wherein the means for sizing cuttings
- 20 comprises a sizing grill proximal to the auxiliary cutting tool.
6. The tool of any one of claims 1 to 5 wherein the locomotion system enables the auxiliary mining tool to traverse seafloor terrain sloped up to about 10 degrees.
7. The tool of claim 6 wherein the locomotion system enables the auxiliary mining tool to traverse seafloor terrain sloped up to about 20 degrees.
- 25 8. The tool of claim 7 wherein the locomotion system enables the auxiliary mining tool to traverse seafloor terrain sloped up to about 25 degrees.
9. The tool of any one of claims 1 to 8 wherein the boom for mounting the auxiliary cutting tool comprises an hydraulically operated articulated arm mounted on an upper carriage assembly capable of slewing relative to the auxiliary mining tool centre line.

10. The tool of any one of claims 1 to 9 when operable at depths greater than about 400m.
11. The tool of claim 10 when operable at depths greater than about 1000m.
12. The tool of claim 11 when operable at depths greater than about 1500m.
- 5 13. The tool of any one of claims 1 to 12 further comprising a suction delivery line having a slurry inlet adjacent to the auxiliary cutting tool and configured to capture cuttings in the form of a slurry for delivery to an outlet spaced apart from the auxiliary mining tool.
14. The tool of claim 13 wherein the slurry inlet is positioned proximal to and aft of
10 the cutting head.
15. The tool of claim 13 wherein the slurry inlet is positioned between cutting heads of the cutting tool.
16. The tool of any one of claims 13 to 15, further comprising a collection shroud which partially surrounds the cutting tool to optimise containment and collection of
15 cuttings by the slurry inlet.
17. The tool of any one of claims 13 to 15, further comprising a blade configured to shroud the cutting tool and clear the path ahead of the auxiliary mining tool by acting as a push blade when the machine traverses forwards.
18. The tool of claim 17 wherein the blade is arcuately shaped so as to effect
20 substantially equal shrouding at differing slew positions of the cutting tool.
19. The tool of any one of claims 1 to 18 further comprising movable anchoring spuds configured to stabilise the tool when deployed.
20. A method for seafloor auxiliary mining in a seafloor mining system, the method comprising:
25 a seafloor auxiliary mining tool traversing the seafloor using a seafloor locomotion system;
the tool receiving power and control signals from a surface source via umbilical connections;
a boom mounted auxiliary cutting tool cutting extremities of a seafloor deposit;
30 and

a sizing means of the tool sizing cuttings produced by the auxiliary cutting tool to ensure such cuttings are no greater than a desired size.

21. The method of claim 20 wherein the auxiliary cutting tool is used in preparation for bulk mining to cut down peripheries of complex seafloor formations in order to
- 5 present relatively flat and horizontal benches suitable for a separate bulk mining tool.
22. The method of claim 20 or claim 21 wherein the auxiliary cutting tool is used to work a seafloor site to prepare a bench for bulk mining.
23. The method of any one of claims 20 to 22 wherein the auxiliary cutting tool is used to work remnant edges left by a bulk miner.
- 10 24. The method of any one of claims 20 to 23 wherein cuttings are captured in slurry form and the slurry is pumped to one side of the path taken or to be taken by the tool.
25. The method of any one of claims 20 to 24 wherein cuttings are captured in slurry form and the slurry is pumped to a seafloor stockpile location spaced apart from
- 15 the seafloor auxiliary mining tool via a suitable transfer pipe.

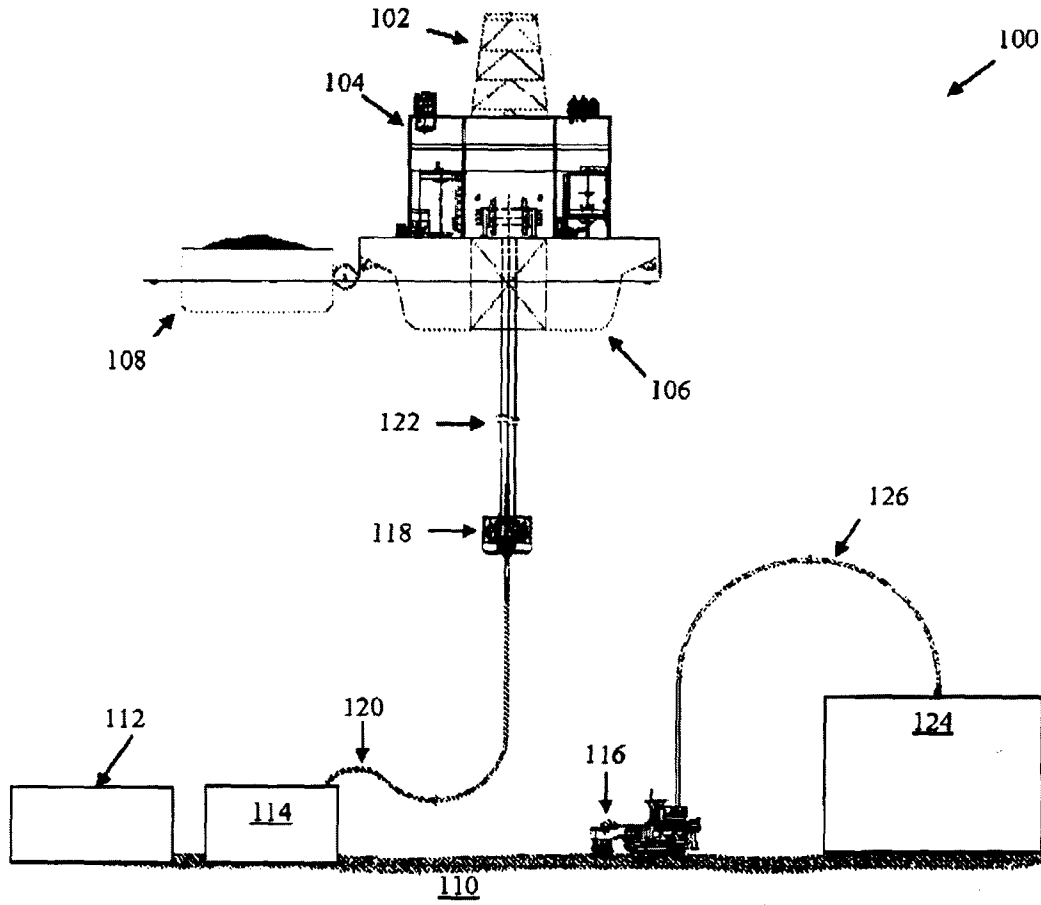

Figure 1

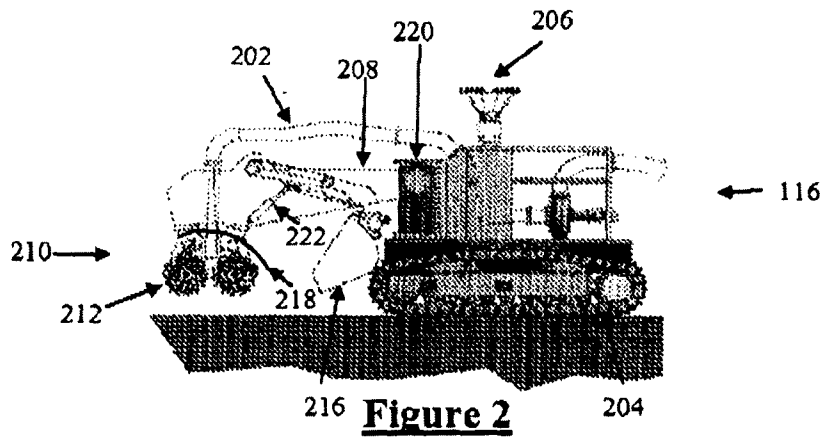

Figure 2

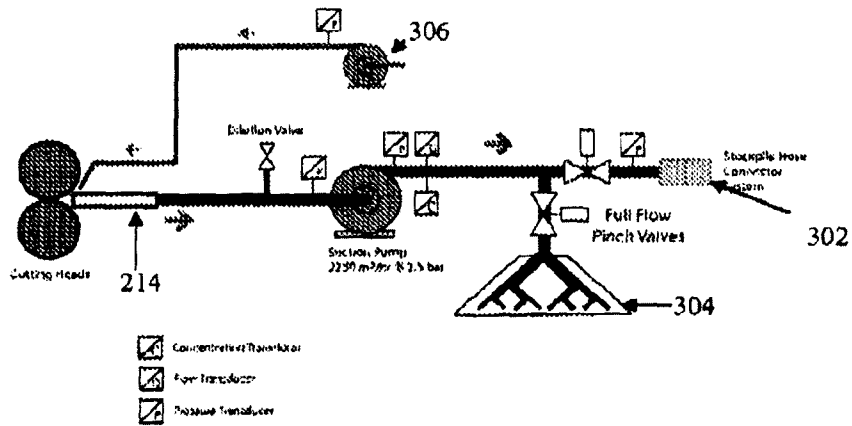

Figure 3

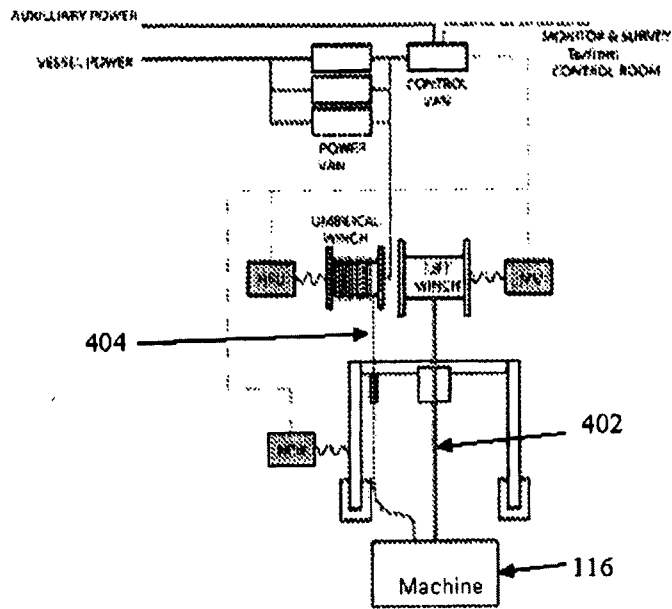

Figure 4

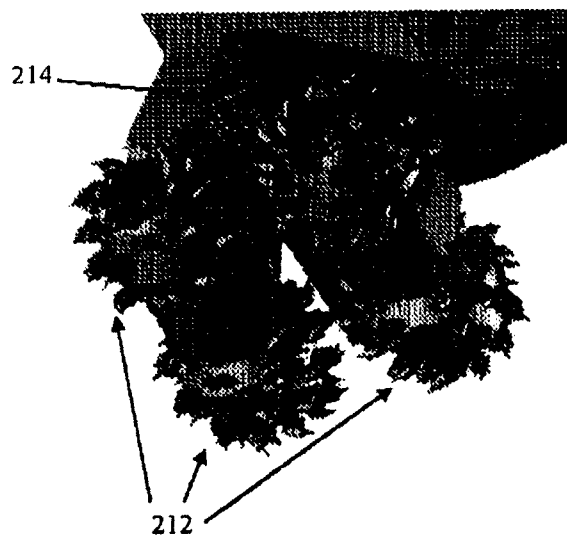

Figure 5

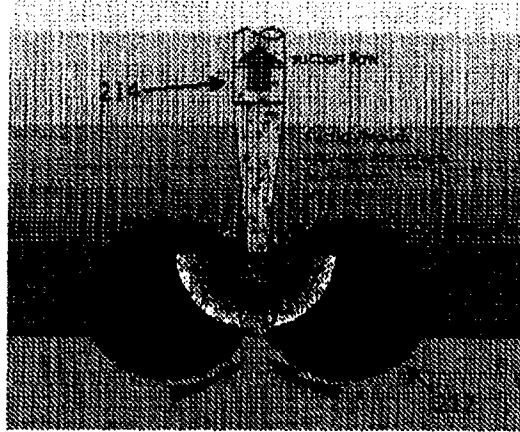

Figure 6

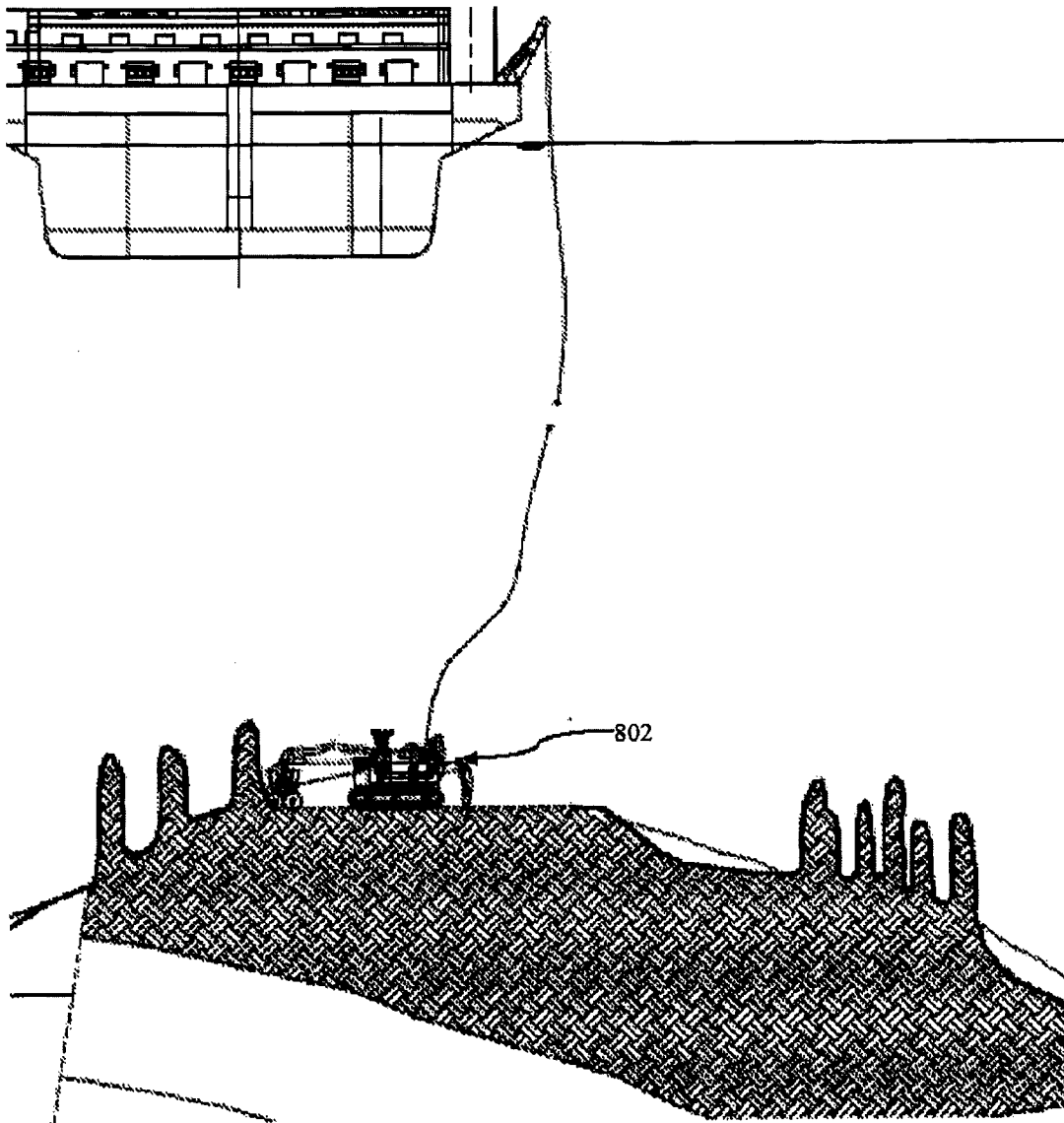

Figure 7a

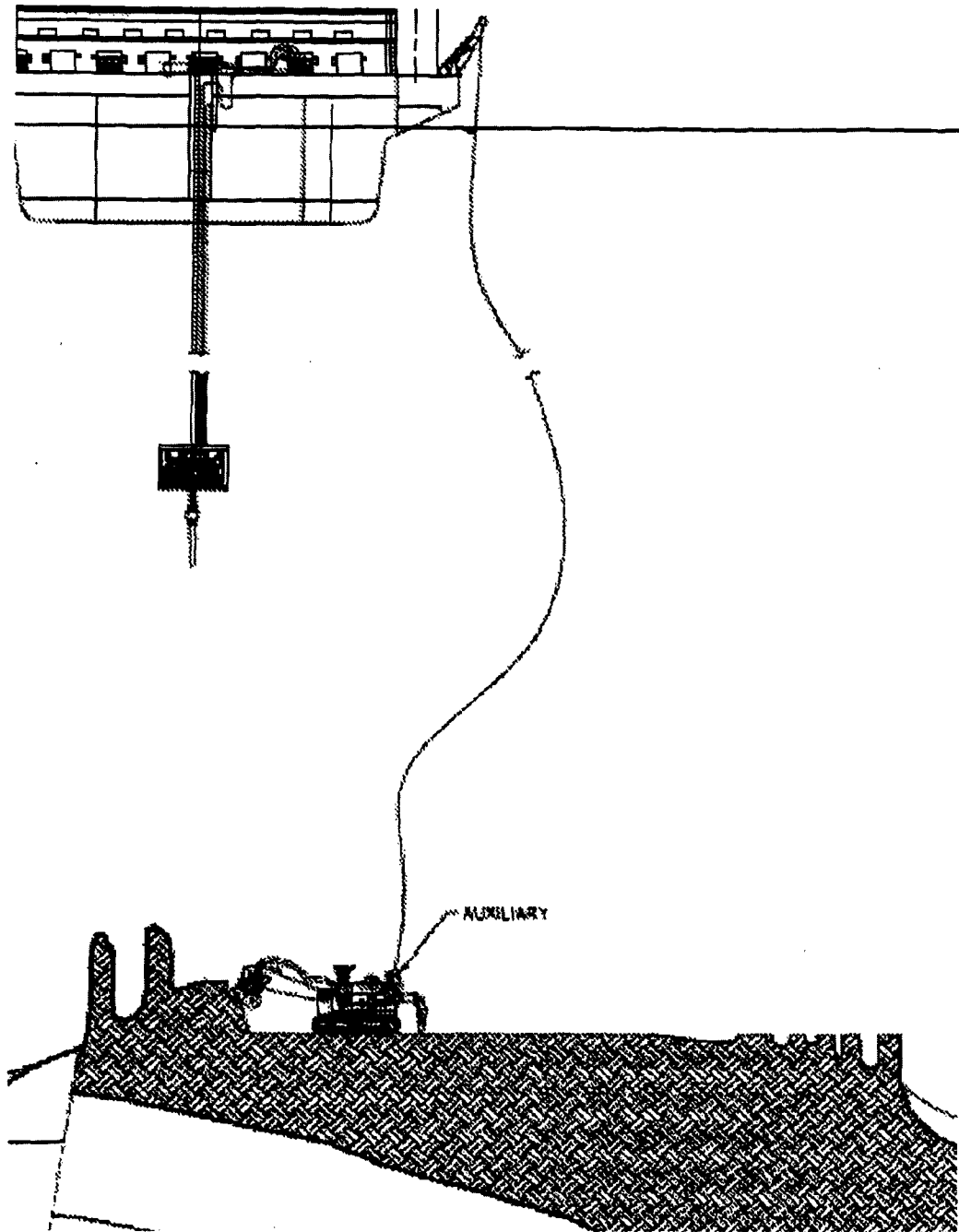

Figure 7b

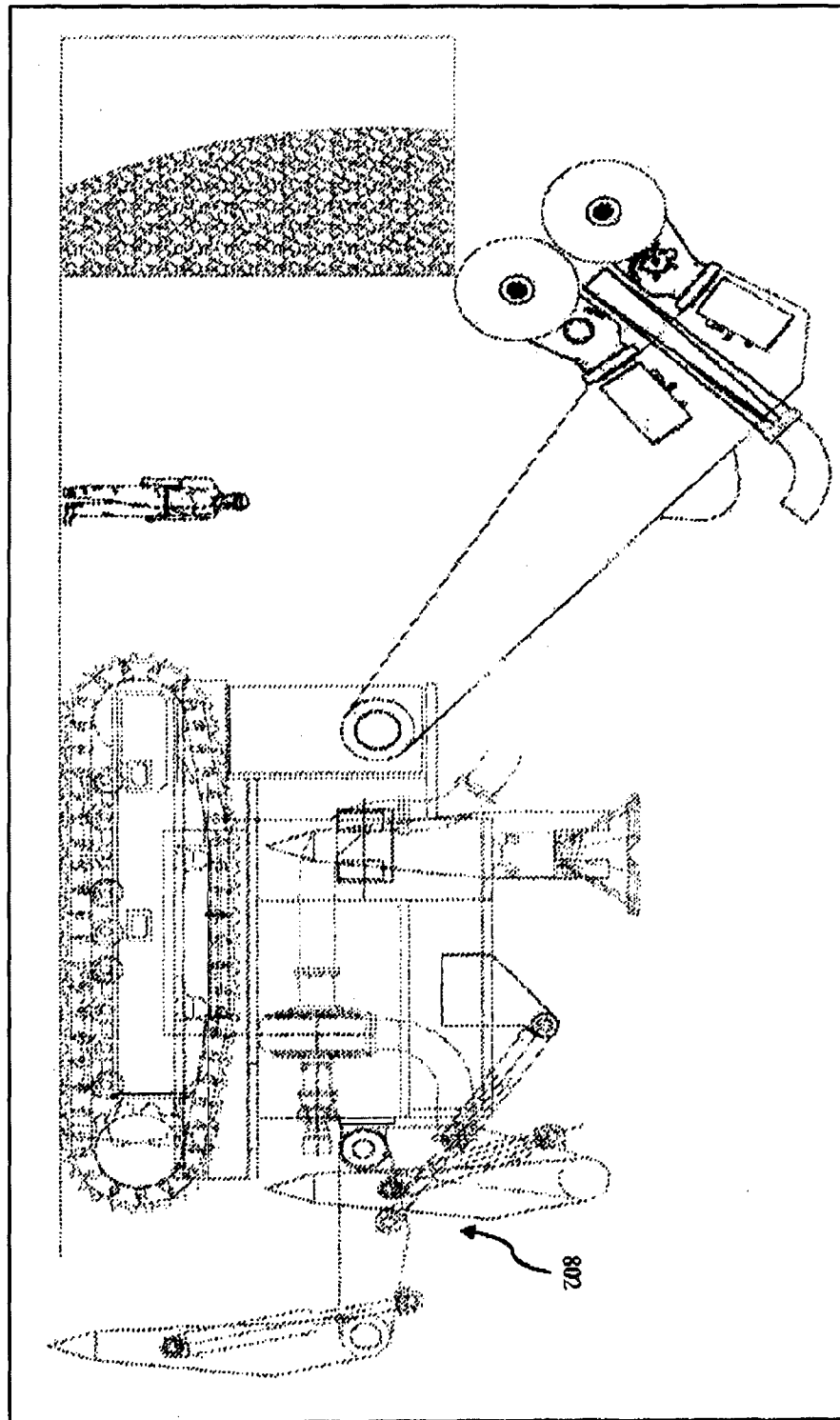

Figure 8

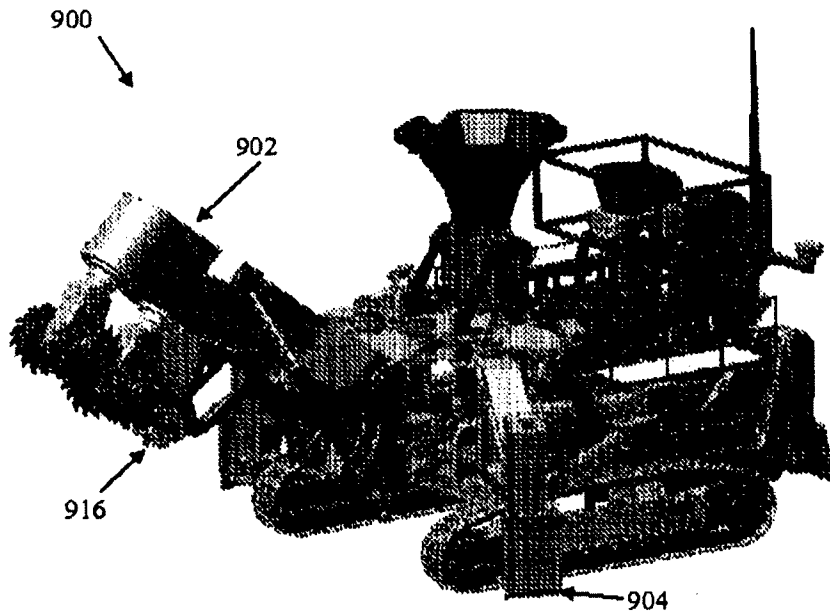

Figure 9a

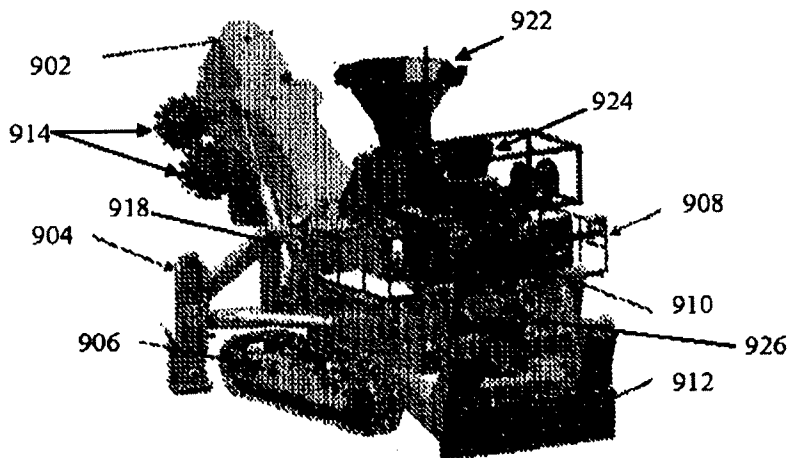

Figure 9b

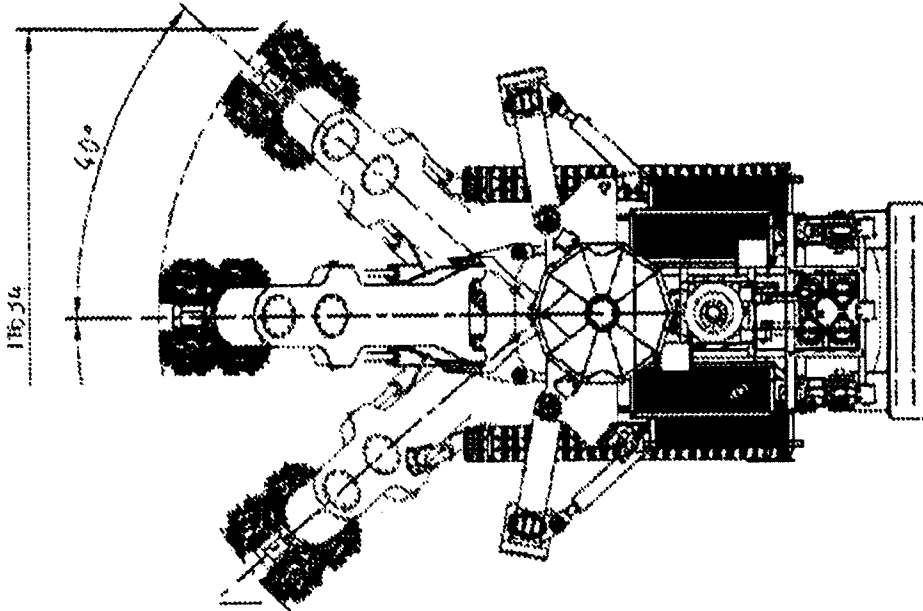

Figure 9c

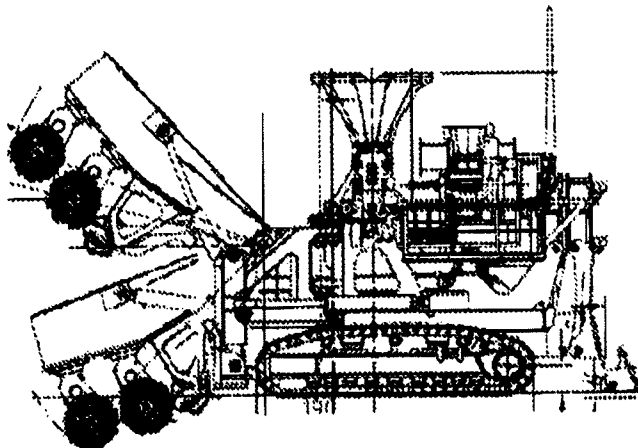

Figure 9d

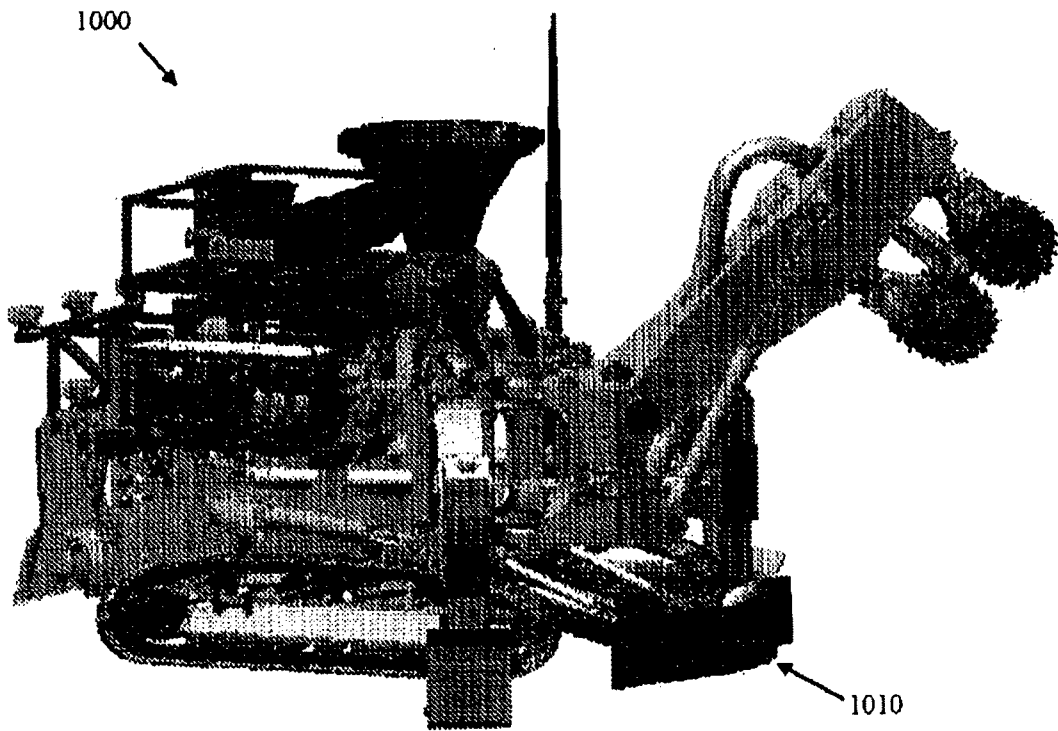

Figure 10a

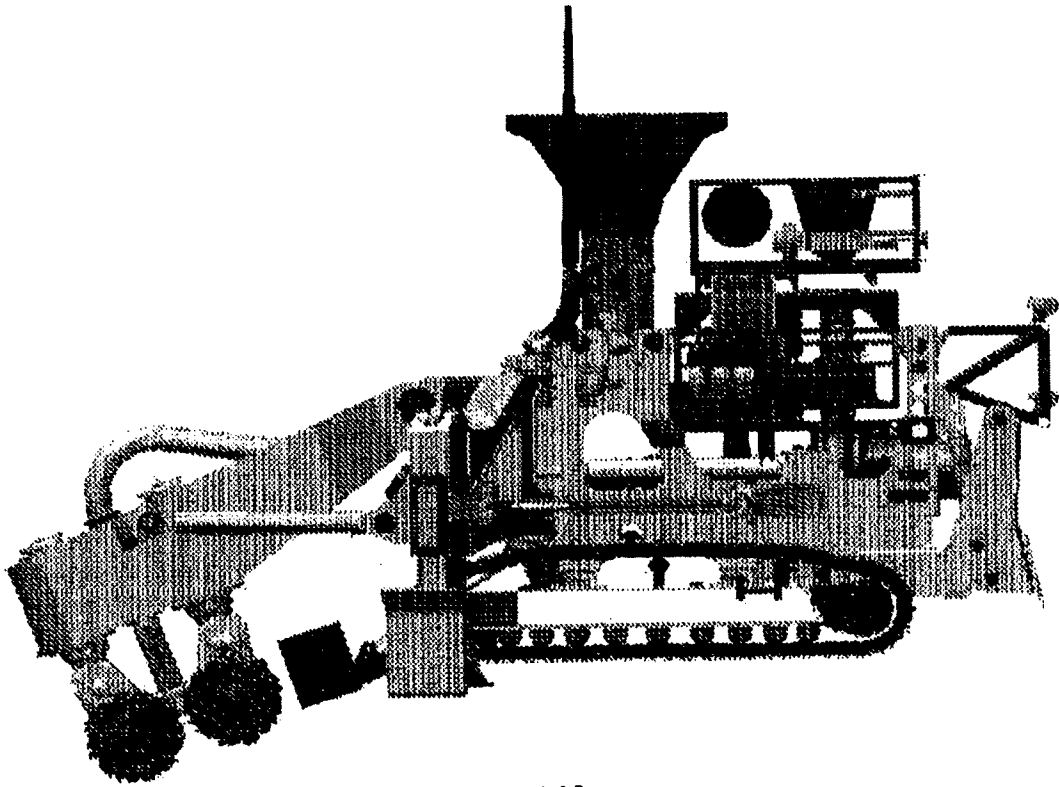

Figure 10b

INTERNATIONAL SEARCH REPORT

International application No.

PCT/AU2011/000731

| A. CLASSIFICATION OF SUBJECT MATTER | | |
|--|--|---|
| Int. Cl. | | |
| <i>E02F 3/88</i> (2006.01) <i>E02F 9/14</i> (2006.01) | | |
| According to International Patent Classification (IPC) or to both national classification and IPC | | |
| B. FIELDS SEARCHED | | |
| Minimum documentation searched (classification system followed by classification symbols) | | |
| Documentation searched other than minimum documentation to the extent that such documents are included in the fields searched | | |
| Electronic data base consulted during the international search (name of data base and, where practicable, search terms used) | | |
| WPI, EPODOC, IPC, ECLA: E02F, B02C, E21C & KW: sea_floor, sea_bed, underwater, sub_sea, sea_bottom, ocean_floor, vehicle, machine, locomotion, mobile, rov, track, crawl, tractor, endless, caterpillar, umbilical, riser, deliver, line, cable, cut, drill, mine, excavate, pump, suction, lift, draw, size, screen, rotate, rotary, head, drum & like terms. | | |
| C. DOCUMENTS CONSIDERED TO BE RELEVANT | | |
| Category* | Citation of document, with indication, where appropriate, of the relevant passages | Relevant to claim No. |
| X | WO 1998/042922 A1 (DE BEERS MARINE PTY. LTD.) 1 October 1998 Figure 1, pages 4-6 | 1,5-9,13-15,17,18,20-25 2-4,10-12,19 |
| Y | Figure 1, pages 4-6 | |
| X | JP 09-302713 A (MITSUBISHI HEAVY IND. LTD.) 25 November 1997 Abstract (English abstract retrieved from EPODOC database), figures 1-3 | 1,5-9,13-16,18,20 2-4,10-12,19 |
| Y | Abstract (English abstract retrieved from EPODOC database), figures 1-3 | |
| Y | FR 2612987 A1 (SOLETANCHE) 30 September 1988 Figures 2 and 4 | 2-4 |
| Y | US 3456371 A (GRAHAM et al.) 22 July 1969 Col. 5 line 47 | 10-12 |
| <input checked="" type="checkbox"/> Further documents are listed in the continuation of Box C <input checked="" type="checkbox"/> See patent family annex | | |
| * Special categories of cited documents: | "T" later document published after the international filing date or priority date and not in conflict with the application but cited to understand the principle or theory underlying the invention | |
| "A" document defining the general state of the art which is not considered to be of particular relevance | "X" document of particular relevance; the claimed invention cannot be considered novel or cannot be considered to involve an inventive step when the document is taken alone | |
| "E" earlier application or patent but published on or after the international filing date | "Y" document of particular relevance; the claimed invention cannot be considered to involve an inventive step when the document is combined with one or more other such documents, such combination being obvious to a person skilled in the art | |
| "L" document which may throw doubts on priority claim(s) or which is cited to establish the publication date of another citation or other special reason (as specified) | "&" document member of the same patent family | |
| "O" document referring to an oral disclosure, use, exhibition or other means | | |
| "P" document published prior to the international filing date but later than the priority date claimed | | |
| Date of the actual completion of the international search 31 August 2011 | Date of mailing of the international search report 27/09/2011 | |
| Name and mailing address of the ISA/AU AUSTRALIAN PATENT OFFICE PO BOX 200, WODEN ACT 2606, AUSTRALIA E-mail address: pct@ipaaustralia.gov.au Facsimile No. +61 2 6283 7999 | Authorized officer G. THOMPSON AUSTRALIAN PATENT OFFICE (ISO 9001 Quality Certified Service) Telephone No : +61 2 6283 2405 | |

INTERNATIONAL SEARCH REPORT

International application No.
PCT/AU2011/000731

| C (Continuation). DOCUMENTS CONSIDERED TO BE RELEVANT | | |
|---|--|-----------------------|
| Category* | Citation of document, with indication, where appropriate, of the relevant passages | Relevant to claim No. |
| Y | FR 1553816 A (CHABANIER) 17 January 1969 Figure 1 | 19 |

INTERNATIONAL SEARCH REPORT

Information on patent family members

International application No.

PCT/AU2011/000731

This Annex lists the known "A" publication level patent family members relating to the patent documents cited in the above-mentioned international search report. The Australian Patent Office is in no way liable for these particulars which are merely given for the purpose of information.

| Patent Document Cited in Search Report | Patent Family Member |
|--|----------------------|
| WO 98042922 | NONE |
| JP 9302713 | NONE |
| FR 2612987 | DE 3809768 |
| US 3456371 | BE 680695 DE 1634854 |
| FR 1553816 | NONE |

Due to data integration issues this family listing may not include 10 digit Australian applications filed since May 2001.

END OF ANNEX