

(19) World Intellectual Property Organization
International Bureau



(43) International Publication Date
11 June 2009 (11.06.2009)

PCT

(10) International Publication Number
WO 2009/072744 A2

(51) International Patent Classification:
F24D 19/10 (2006.01)

Sung-Duk [KR/KR]; 109-102, Samsung Raemian Apt., Cheoncheon-dong, Jangan-gu, Suwon-si, Gyeonggi-do 440-723 (KR).

(21) International Application Number:
PCT/KR2008/006242

(74) Agent: **CHO, Chul-Hyun**; Oori Patent & Law Office, #1301, Yeosam B/D 10F, 648-23 Yoksam-dong, Gangnam-gu, Seoul 135-748 (KR).

(22) International Filing Date: 22 October 2008 (22.10.2008)

(25) Filing Language: Korean

(81) Designated States (unless otherwise indicated, for every kind of national protection available): AE, AG, AL, AM, AO, AT, AU, AZ, BA, BB, BG, BH, BR, BW, BY, BZ, CA, CH, CN, CO, CR, CU, CZ, DE, DK, DM, DO, DZ, EC, EE, EG, ES, FI, GB, GD, GE, GH, GM, GT, HN, HR, HU, ID, IL, IN, IS, JP, KE, KG, KM, KN, KP, KZ, LA, LC, LK, LR, LS, LT, LU, LY, MA, MD, ME, MG, MK, MN, MW, MX, MY, MZ, NA, NG, NI, NO, NZ, OM, PG, PH, PL, PT, RO, RS, RU, SC, SD, SE, SG, SK, SL, SM, ST, SV, SY, TJ, TM, TN, TR, TT, TZ, UA, UG, US, UZ, VC, VN, ZA, ZM, ZW.

(26) Publication Language: English

(30) Priority Data:
10-2007-0127042
7 December 2007 (07.12.2007) KR

(71) Applicant (for all designated States except US): **KYUNG-DONG NETWORK CO., LTD.** [KR/KR]; 13-6, Yeouido-dong, Yeongdeungpo-gu, Seoul 150-729 (KR).

(72) Inventors; and

(75) Inventors/Applicants (for US only): **DO, Nam-Soo** [KR/KR]; 101-2201, Sindorim 1-cha Donga Apt., 643, Sindorim-dong, Guro-gu, Seoul 152-773 (KR). **CHO,**

(84) Designated States (unless otherwise indicated, for every kind of regional protection available): ARIPO (BW, GH, GM, KE, LS, MW, MZ, NA, SD, SL, SZ, TZ, UG, ZM, ZW), Eurasian (AM, AZ, BY, KG, KZ, MD, RU, TJ, TM), European (AT, BE, BG, CH, CY, CZ, DE, DK, EE, ES, FI,

[Continued on next page]

(54) Title: DEVICE FOR CONTROL ROOM TEMPERATURE OF EACH ROOM ADAPTED TO HEATING ENVIRONMENT AND ITS METHOD

[Fig. 2]

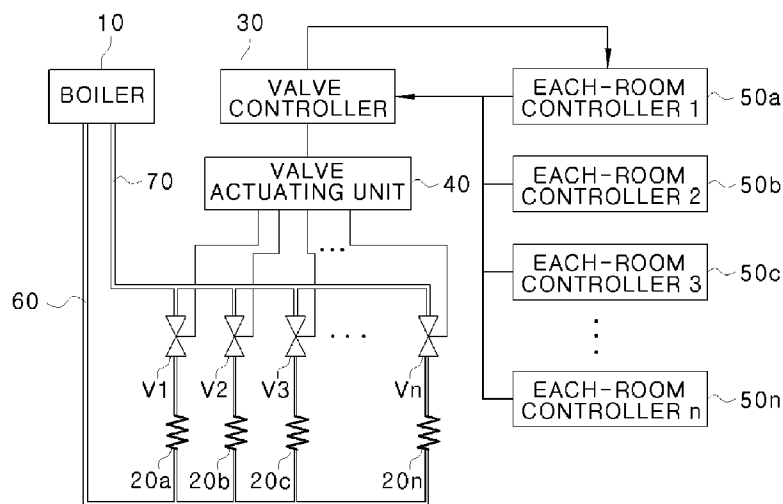

(57) Abstract: The present invention relates to a device for control room temperature of each room adapted to heating environment that allows a temperature control system to be adapted by itself to heating environment (quantity of heat of a heating source, magnitude of load, difference between setting temperature and room temperature) by reflecting the changes in the heating environment and data obtained by previous heating into the control, and reduces unnecessary energy consumption by controlling the quantity of heat of a boiler at the minimum required level. In order to achieve the above, the present invention includes: a boiler that creates combustion heat, exchanges the heat with heating water, and then circulates the heating water through each heating load; one or more heat

pipes that are provided to heating positions; heating control valves that is provided to allow or stop the circulation of the heating water through the heat pipes; an individual room controller that makes it possible to set interior temperature for each room, and converts the set interior temperature into return water control temperature and then outputs the return water control temperature; a valve controller that controls quantity of heat of the boiler by integrating the return water control temperature transmitted from one or more individual room controllers and outputs a control signal to the boiler to maintain the highest return water control temperature of the return water control temperature required by the individual room controller; and a valve actuating unit that turns on/off the valve control valve according to the control signal of the valve controller.

WO 2009/072744 A2



FR, GB, GR, HR, HU, IE, IS, IT, LT, LU, LV, MC, MT, NL,
NO, PL, PT, RO, SE, SI, SK, TR), OAPI (BF, BJ, CF, CG,
CI, CM, GA, GN, GQ, GW, ML, MR, NE, SN, TD, TG).

Published:

— *without international search report and to be republished
upon receipt of that report*

Description

DEVICE FOR CONTROL ROOM TEMPERATURE OF EACH ROOM ADAPTED TO HEATING ENVIRONMENT AND ITS METHOD

Technical Field

- [1] The present invention relates to a device for control room temperature of each room adapted to a heating environment and its method in an individual room temperature control system, more specifically to a device for control room temperature of each room adapted to a heating environment that allows a temperature control system to be adapted by itself to a heating environment (quantity of heat of a heating source, magnitude of load, difference between setting temperature and room temperature) by reflecting changes in the heating environment and data obtained by previous heating into the control, and reduces unnecessary energy consumption by controlling the quantity of heat of the heating source (boiler) at the minimum required level by integrating the requirements of individual rooms.

Background Art

- [2] In general, heating apparatuses implement apparatuses that supply warm water to a heating system, etc., which burn fuel therein, such as gas, heat heating water using combustion heat created by the combustion, and then heat the inside of a room by circulating the heating water through heat pipes provided in the floor, etc. in the room, or supply hot water using the heating water.
- [3] Control methods for maintaining the interior temperature at user-desired setting temperature in this heating apparatuses can be divided into a method of turning on/off a heating apparatus by measuring the interior temperature, a method of turning on/off a heating apparatus by measuring the temperature of water in a heat pipe, and a method of continuing operation for a time set by a user and stopping the operation for a time set in advance.
- [4] The method of controlling the heating temperature while measuring the interior temperature in the above methods turns on/off the heating apparatus by comparing the temperature set by the user with the interior temperature measured by a temperature sensor attached to an interior temperature controller, and a process that is controlled by the method is shown in FIG. 1.
- [5] FIG. 1 is a graph illustrating a change process of the interior temperature according to a method of controlling a heating apparatus in the related art.
- [6] First, a user sets the desired interior temperature using an interior temperature controller provided in a room, in which the set interior temperature becomes T_{set} , and

heating stop temperature T_{off} and heating start temperature T_{on} are set within a pre-determined range above and below the interior temperature T_{set} set by the user.

- [7] The heating stop temperature T_{off} and heating start temperature T_{on} are values inputted in advance in the interior temperature controller, and for example, when the user set desired interior temperature at 25°C, the heating stop temperature T_{off} may be set to 26°C and heating start temperature T_{on} may be set to 24°C to have a range of 1°C above and under the set temperature.
- [8] As the heating system operates, the interior temperature increases, in which the interior temperature is detected by a temperature sensor attached to the interior temperature controller. When the interior temperature detected by the temperature sensor reaches the heating stop temperature T_{off} of 26°C, the user judges that the desired temperature is achieved and stops the heating apparatus.
- [9] In this case, although heat transfer to heat pipes embedded in the floor is stopped by the stop of the heating apparatus, the interior temperature drops after increasing up to temperature higher the heating stop temperature T_{off} of 26°C (e.g. 27°C), because heat stored in the floor continues to be discharged into the interior air. It is called overshoot when the interior temperature increases more than the heating stop temperature T_{off} , as described above.
- [10] The interior temperature drops due to the stop of the heating apparatus, and when the interior temperature reaches the heating start temperature T_{on} of 24°C, the heating apparatus is restarted.
- [11] In this case, although the interior temperature drops due to the stop of the heating apparatus, the interior temperature re-increases after dropping to temperature (e.g. 23°C) lower than the heating start temperature T_{on} . It is called undershoot when the interior temperature drops less than the heating start temperature T_{on} .

Disclosure of Invention

Technical Problem

- [12] There was a problem in that the up-down change range increases to 23°C ~ 27°C from the interior temperature T_{set} of 25°C set by the user, when the overshoot and undershoot are generated as described above, such that it is difficult to provide pleasant environment.
- [13] That is, since methods of controlling the interior temperature in the related art uniformly performs control regardless of changes in the heating environment, the range of the interior temperature increasing/decreasing from the set temperature is large and the user feels the same changes in temperature without resolving the problem even though the control is repeated. Further, since individual room control systems in the related art controls the interior temperature by only turning on/off valves, without

controlling quantity of heat of heating sources, there was a problem in that differences in the temperature are large and energy is unnecessarily consumed correspondingly.

- [14] The present invention is designed to overcome the above problems, it is an object of the present invention to provide a device for control room temperature of each room adapted to a heating environment that converts interior temperature set by an individual room controller into needed quantity of heat and controls a boiler to supply needed quantity of heat by integrate the interior temperature, using a valve controller, in which the individual room controller controls valves to turn on/off by comparing the quantity of heat supplied by the boiler from the valve controller with quantity of heat needed for each room and then determining the changes in the heating environment, in order to be adapted by itself to the heating environment, and a method of controlling room temperature of each room adapted to the heating environment.

Technical Solution

- [15] In order to achieve the above objects of the present invention, a device for control room temperature of each room adapted to a heating environment, includes: a boiler that creates heat, exchanges the heat with heating water, and then circulates the heating water through each heating load; one or more heat pipes that are provided to heating positions; heating control valves that is provided to allow or stop the circulation of the heating water through the heat pipes; an individual room controller that makes it possible to set the interior temperature for each room, and converts the set interior temperature into return water control temperature and then outputs the return water control temperature; a valve controller that controls the quantity of heat of the boiler by integrating the return water control temperature transmitted from one or more individual room controllers and outputs a control signal to the boiler to maintain the highest return water control temperature of the return water control temperature required by the individual room controller; and a valve actuating unit that turns on/off the valve control valve according to the control signal of the valve controller.
- [16] Further, in order to achieve the above objects of the present invention, a method of controlling room temperature of each room adapted to heating environment, includes:
- [17] outputting return water control temperature of each room after converting an interior temperature set by a user through an individual room controller into the return water control temperature of each room; controlling the quantity of heat of a boiler to maintain the highest control from the return water control temperature of each room received by the valve controller; multiplying a value, which is obtained by subtracting the return water control temperature of a room to be controlled from the return water control temperature of the boiler, by a control calibrating constant, and then determining an object value for control of the interior temperature by subtracting the

above value from the set interior temperature; performing heating by opening a heating control valve until the present interior temperature increases higher than valve closing temperature, which is set in advance, when the present interior temperature is lower than valve opening temperature that is set in advance, in the individual room controller; detecting a difference in temperature between the temperature when the interior temperature of each room is higher than the valve opening temperature in the heating, in the performing of heating, and the temperature when the interior temperature of each room is lower than the valve closing temperature in stopping the heating; and controlling opening/closing of the heating control valve at a renewal object value for control which is obtained by reflecting the difference in temperature to the return water control temperature of the previous control cycle, before performing again heating, as the present interior temperature becomes lower than the valve opening temperature that is set in advance.

- [18] The return water control temperature of the boiler is set to the highest return water control temperature of the return water control temperature of each room in the performing of heating.

Advantageous Effects

- [19] The present invention is advantageous in achieving more effective control, as compared with individual room control systems that do not controlling a heat source, by reducing the differences in temperature that repeatedly occur, using a method of controlling a heating system that is adapted to a heating environment by itself, and in saving energy by reducing unnecessary waste of energy.

Brief Description of Drawings

- [20] FIG. 1 is a graph illustrating a change process of the interior temperature according to a method of controlling a heating apparatus in the related art.
- [21] FIG. 2 is a view illustrating the configuration for achieving the present invention.
- [22] FIG. 3 is a flowchart illustrating a method of controlling room temperature of each room adapted to heating environment according to the present invention.

Best Mode for Carrying out the Invention

- [23] The configuration and operation of a preferred embodiment of the invention is described hereafter in detail with reference to the accompanying drawing.
- [24] FIG. 2 is a view illustrating the configuration for achieving the present invention.
- [25] In the accompanying drawings, a boiler 10 creates combustion heat by burning gas or oil in a combustion chamber, exchanges the heat with heating water in a heat exchanger disposed in the boiler 10, heats each room by supplying the heating water to heat pipe unit 20:20a, 20b, 20c ~ 20n provided in each room through a heating water discharge pipe 60, returns the heating water of which the temperature has dropped to a

low temperature through a heating water return pipe 70, heats again the heating water at high temperature by exchanging heat with combustion heat, and then supplies the heating water to the heat pipe unit 20, which is repeated.

- [26] The fuel, such as gas or oil, which is supplied to create combustion engine while burning in the boiler 10 is supplied, for example, through a proportional control valve (not shown). Accordingly, it is possible to adjust the quantity of heat created in the boiler 10 by controlling the amount of opening of the proportional control valve to adjust the amount of fuel that is supplied into the combustion chamber.
- [27] The heat pipe unit 20 may be composed of one or more heat pipes for each room.
- [28] Heating control valves V1 ~ Vn that opens/closes the heat pipes to circulate or stop the heating water are disposed at a side of the heat pipes. The heating control valves V1 ~ Vn is controlled to open/close by a valve actuating unit 40 that is controlled by a valve controller 30.
- [29] Individual room controllers 50: 50a, 50b, 50c ~ 50n each have a function of enabling a user to set desired interior temperature for each room and are equipped with an interior temperature detecting unit (not shown) to control the interior temperature at desired level by detecting the interior temperature. One individual room controller 50 is provided for each room, but is not limited thereto and a plurality of room controllers may be provided in a large room. Further, one room controller may be provided to control a plurality of rooms, if necessary.
- [30] The valve controller 30 controls quantity of heat of the boiler 10 by integrating information on the quantity of heat transmitted from the individual room controllers 50 while controlling the heating control valves V1 ~ Vn to turn on/off by controlling the valve actuating unit 40.
- [31] When interior heating temperature is set by a user, the individual room controller 50 converts the set temperature into boiler return water control temperature and transmits it to the valve controller 30 and the valve controller 30 correspondingly controls the quantity of heat of the boiler 10 by integrating the return water control temperature of each room required by the individual room controller 50, in which the quantity of heat of the boiler 10 is controlled to the quantity of heat where the highest temperature of the return water control temperature of each room set by the individual room controller 50 can be maintained.
- [32] When the boiler 10 is in operation and the practical boiler control return water temperature is higher than the return water control temperature required by each room, the heating control valve is turned off by reflecting the above such that overshoot is prevented.
- [33] The boiler 10 is controlled to create the quantity of heat that is needed to maintain the return control water temperature set by the user in each room, such that it is possible to

prevent unnecessary waste of fuel.

[34] FIG. 3 is a flowchart illustrating a method of controlling room temperature of each room adapted to a heating environment according to the present invention.

[35] First, as a user sets desired interior temperature for each room by operating the individual room controller 50, the individual room controller 50 calculates return water control temperature of each room for keeping the interior temperature at the set temperature and transmits the calculated result to the valve controller 30.

[36] The valve controller 30 integrates the return water control temperature of each room transmitted from the individual room controller 50 and then controls the heating control valves V1 ~ Vn to turn on/off while controlling the boiler 10 to maintain the highest return water control temperature of each room (S2).

[37] The individual room controller 50 calculates an object value for control of the interior temperature to maintain the interior temperature set by the user for each room as follow,

[38] $T(n) = \text{set interior temperature} - K_s \Delta t$

[39] where $T(n)$ is a new object value for control according to the interior temperature set by the user, K is a control calibration constant, and Δt is boiler return water control temperature - return water control temperature of the room to be controlled.

[40] The individual room controller 50 controls the heating control valve V1 ~ Vn to turn on/off such that the object value for control $T(n)$ calculated as described above is maintained.

[41] The individual room controller 50 determines whether the present interior temperature is lower than valve opening temperature Temp_ON (S3) and then opens the heating control valve of the corresponding room to start heating when it is lower than the valve opening temperature Temp_ON (S4).

[42] Thereafter, it is determined whether the present interior temperature increases higher than valve closing temperature Temp_OFF to determine whether the heating is achieved up to the set temperature (S5), and then the heating control valve of the corresponding room is closed to stop the heating when it is determined that it is higher than the valve closing temperature Temp_OFF (S6).

[43] After one cycle from the heating start to the heating stop as described above is made, the overshoot higher than the set temperature when the heating is started and the undershoot lower than the set temperature, that is, a difference in temperature from the set temperature is calculated (S7), it is determined whether the present interior temperature is lower than the valve opening temperature Temp_ON (S8), the object value for control of the boiler is renewed by reflecting the difference in temperature when it is determined that it is lower than the valve opening temperature Temp_ON (S9).

- [44] That is, the renewal object value for control is calculated as follow,
- [45] $T(n) = T(n-1) + \text{correction value}$
- [46] where $T(n-1)$ is the object value for control of the previous cycle.
- [47] Meanwhile, after the determining of whether the present interior temperature is lower than the valve opening temperature Temp_ON is performed in the individual room controller 50 in step S3 (S3), when it is determined that the present interior temperature is higher than the valve opening temperature Temp_ON, it is determined whether the present interior temperature increases higher than the valve closing temperature Temp_OFF (S10).
- [48] When it is determined that the present interior temperature is not higher than the valve closing temperature Temp_OFF, heating water continues to be supplied to the corresponding room until it is determined that it increases higher than the valve closing temperature Temp_OFF. Thereafter, as the present interior temperature becomes higher than the valve closing temperature Temp_OFF, the heating is stopped by closing the heating control valve (S11) and the process return to step S3 that determines whether the present interior temperature is lower than the valve opening temperature Temp_ON.
- [49] It is preferable to change the object value for control as described above when the set temperature is changed by the user, and after the control according to the first object value for control is performed, the second object value for control is renewed in consideration of changes in the difference of the overshoot, undershoot, and the boiler return water control temperature obtained during the above control.
- [50] Further, it is possible to control the boiler at quantity of heat, which is suitable for heating each room, by changing return water control temperature of the boiler on the basis of the quantity of heat required by the individual room controller and controlling the quantity of heat of the boiler.
- Industrial Applicability**
- [51] As described above, when the present invention is applied to a temperature control system of individual rooms, the present invention can make it possible to not only make a temperature control system adapted by itself to the heating environment, but prevent unnecessary waste of energy.
- [52]

Claims

- [1] A device for control room temperature of each room adapted to heating environment, comprising:
- a boiler that creates combustion heat, exchanges the heat with heating water, and the circulates the heating water through each heating load;
 - one or more heat pipes that are provided to heating positions;
 - heating control valves that is provided for the heat pipes to allow or stop the circulation of the heating water through the heat pipes;
 - an individual room controller that makes is possible to set interior temperature for each room, and converts the set interior temperature into return water control temperature and then outputs the return water control temperature;
 - a valve controller that controls the quantity of heat of the boiler by integrating the return water control temperature transmitted from one or more individual room controllers and outputs a control signal to the boiler to maintain the highest return water control temperature of the return water control temperature required by the individual room controller; and
 - a valve actuating unit that turns on/off the valve control valve according to the control signal of the valve controller.
- [2] A method of controlling room temperature of each room adapted to heating environment, comprising:
- outputting return water control temperature of each room after converting interior temperature set by a user through an individual room controller into the return water control temperature of each room;
 - controlling the quantity of heat of a boiler to maintain the highest control from the return water control temperature of each room received by the valve controller;
 - multiplying a value, which is obtained by subtracting return water control temperature of a room to be controlled from the return water control temperature of the boiler, by a control calibrating constant, and then determining an object value for control of the interior temperature by subtracting the above value from the set interior temperature;
 - performing heating by opening a heating control valve until the present interior temperature increases higher than the valve closing temperature, which is set in advance, when the present interior temperature is lower than the valve opening temperature that is set in advance, in the individual room controller;
 - detecting a difference in temperature between the temperature when the interior temperature of each room is higher than the valve opening temperature in the

heating, in the performing of heating, and the temperature when the interior temperature of each room is lower than the valve closing temperature in stopping the heating; and

controlling opening/closing of the heating control valve at a renewal object value for control which is obtained by reflecting the difference in temperature to the return water control temperature of the previous control cycle, before performing again heating, as the present interior temperature becomes lower than the valve opening temperature that is set in advance.

- [3] The method of controlling room temperature of each room adapted to heating environment according to claim 2, wherein the return water control temperature of the boiler is set to the highest return water control temperature of the return water control temperature of each room, in the performing of heating.

[Fig. 1]

TEMPERATURE

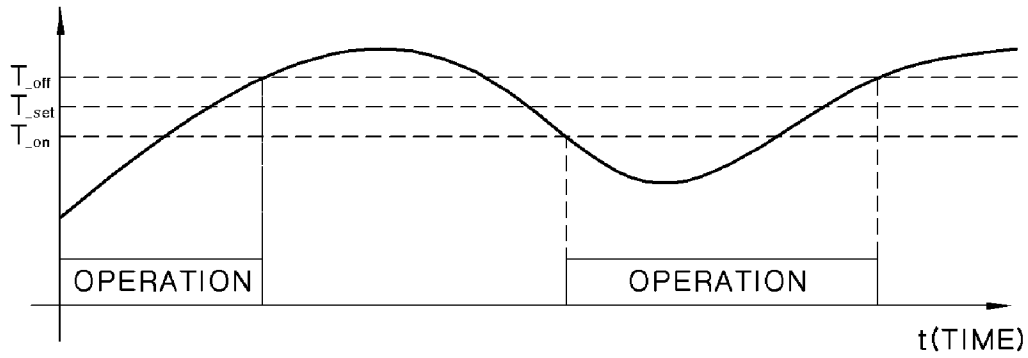

[Fig. 2]

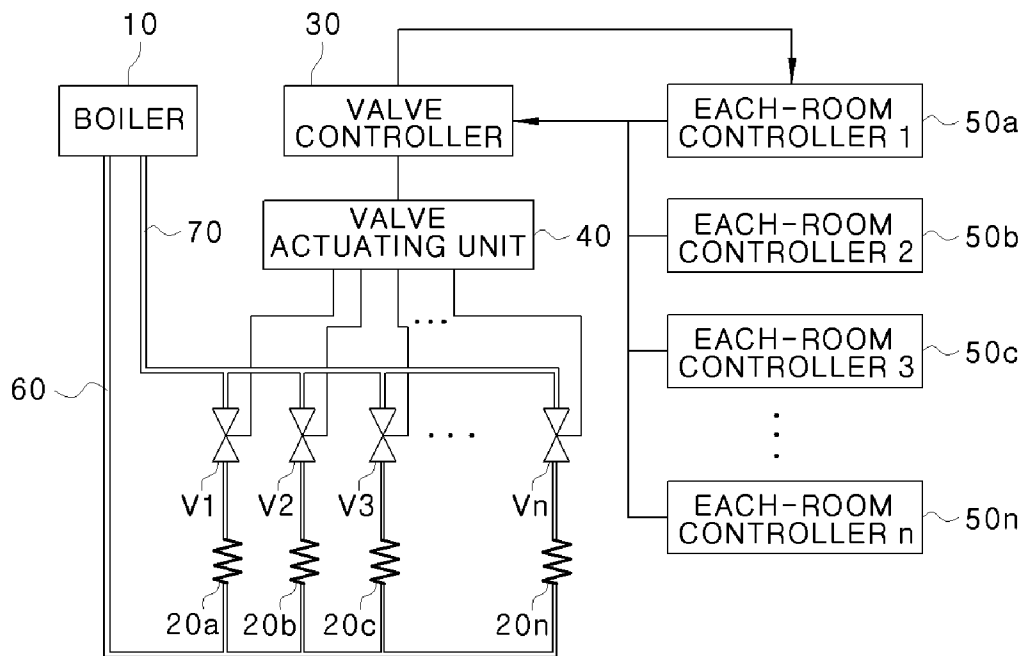

[Fig. 3]

