



US 20030102315A1

(19) **United States**

(12) **Patent Application Publication**

**Cheng et al.**

(10) **Pub. No.: US 2003/0102315 A1**

(43) **Pub. Date: Jun. 5, 2003**

(54) **MESH CONTAINER, SYSTEM USING MESH CONTAINERS AND METHOD FOR MAKING MESH CONTAINERS**

**Publication Classification**

(51) **Int. Cl.<sup>7</sup> .....** B65D 6/08  
(52) **U.S. Cl. ....** 220/485

(76) **Inventors: Hsi-Ming Cheng, Chung-Hua Hsien (TW); R. Neal Post, Springfield, IL (US); Christopher Hardy, Springfield, IL (US)**

(57) **ABSTRACT**

Correspondence Address:  
**Perry J. Saidman, Esq.**  
**SAIDMAN DesignLaw Group**  
**Suite 510**  
**1110 Bonifant Street**  
**Silver Spring, MD 20910 (US)**

The present invention is directed to a container comprising a first piece of mesh material and at least one separate second piece of mesh material. The first piece of mesh is bent to form a bottom wall and a first pair of sidewalls. The second piece of material forms a second pair of sidewalls. When the pieces are joined together, a basket portion with an upwardly-extending opening is formed. The basket portion may further include a runner portion that may be a separate rail connected to the basket portion, thus forming a drawer. When the container is used with a drawer system including a frame, the runner portion is slidably received in a pair of frame runners. This allows the drawer to move with respect to the frame between retracted and extended positions. The present invention is also directed to a method for making such containers.

(21) **Appl. No.: 10/308,699**

(22) **Filed: Dec. 3, 2002**

(30) **Foreign Application Priority Data**

Sep. 11, 2002 (TW)..... 091214244  
Apr. 16, 2002 (TW)..... 091202306  
Dec. 3, 2001 (TW)..... 090220946

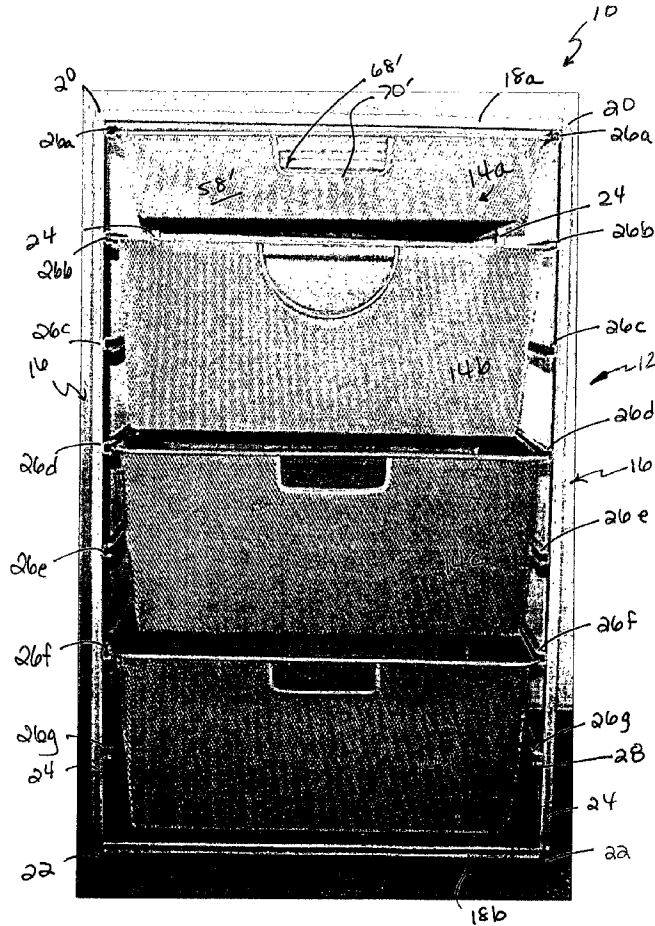

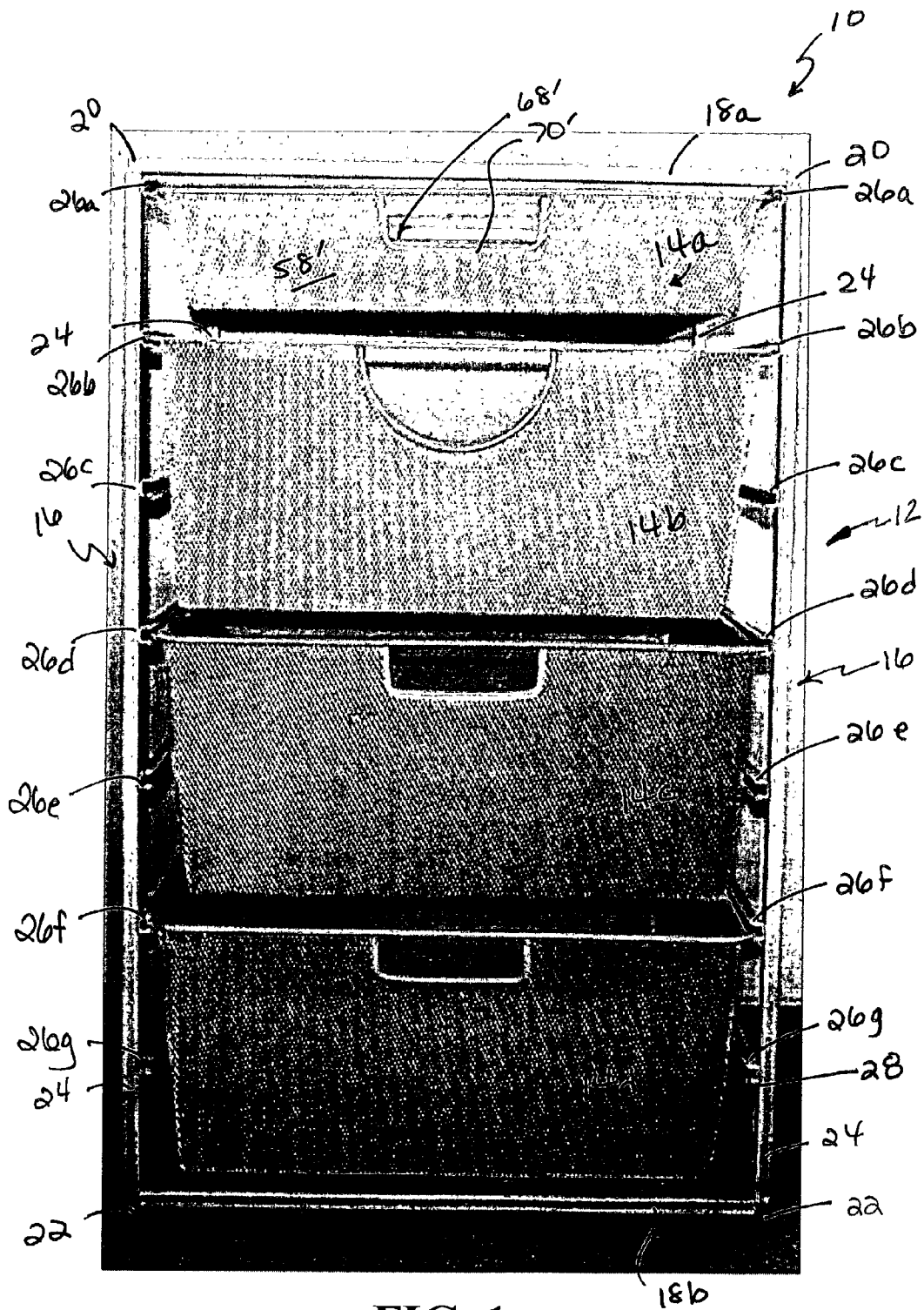
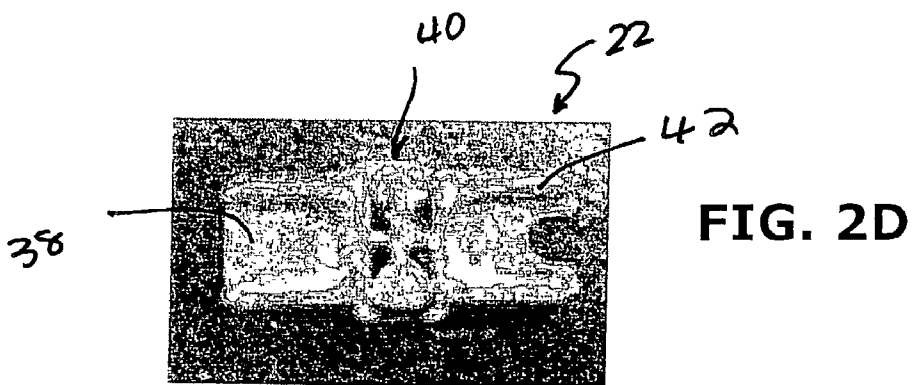
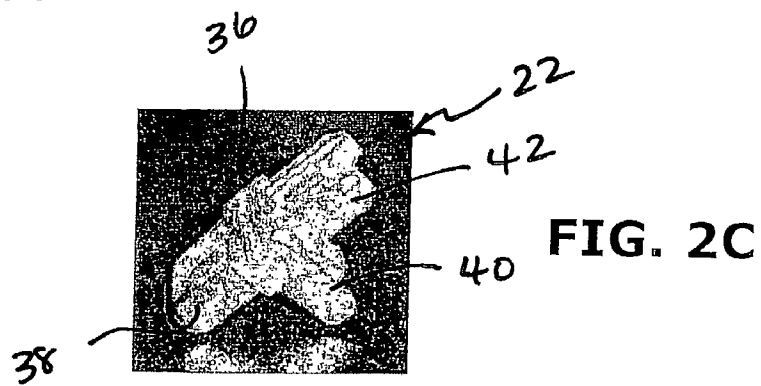
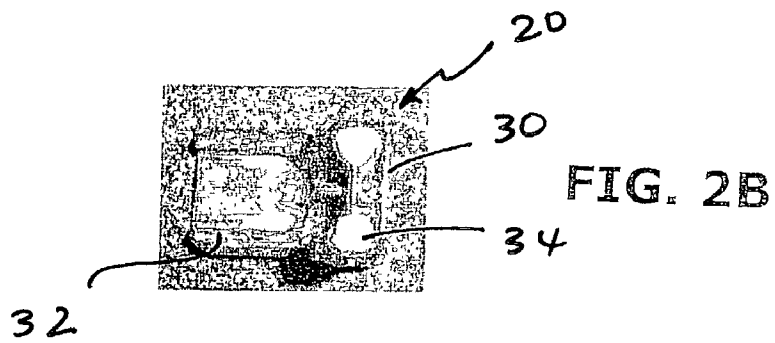
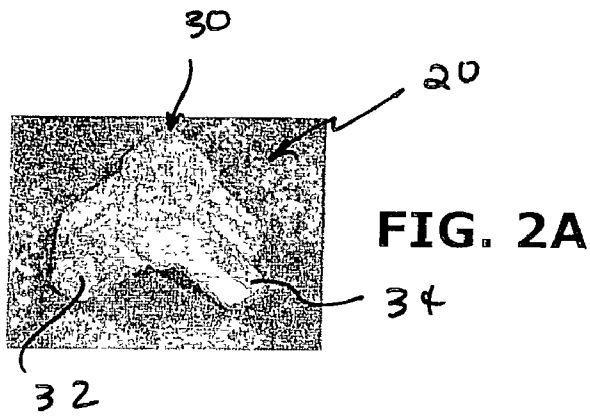

FIG. 1



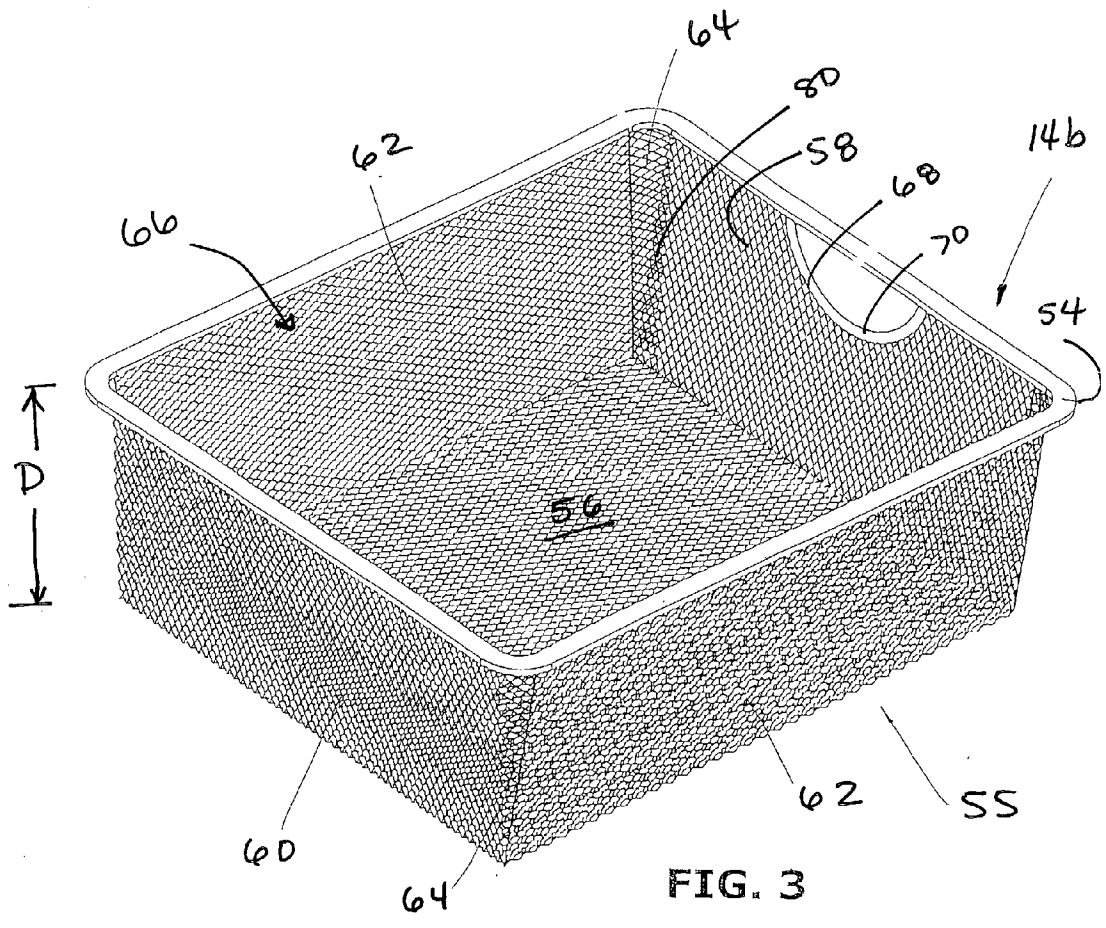

FIG. 3

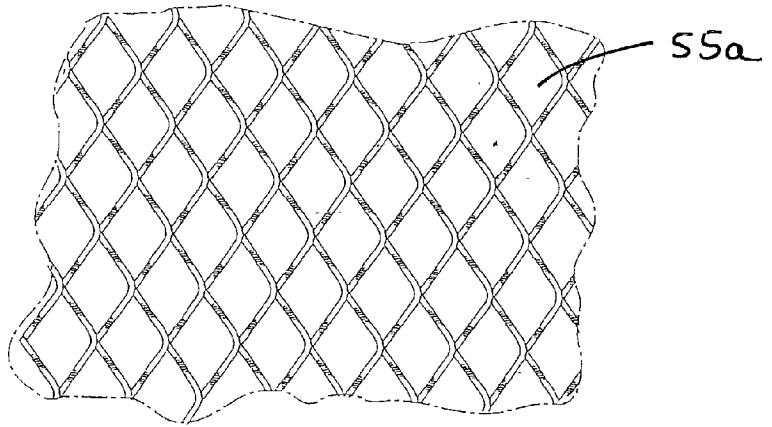
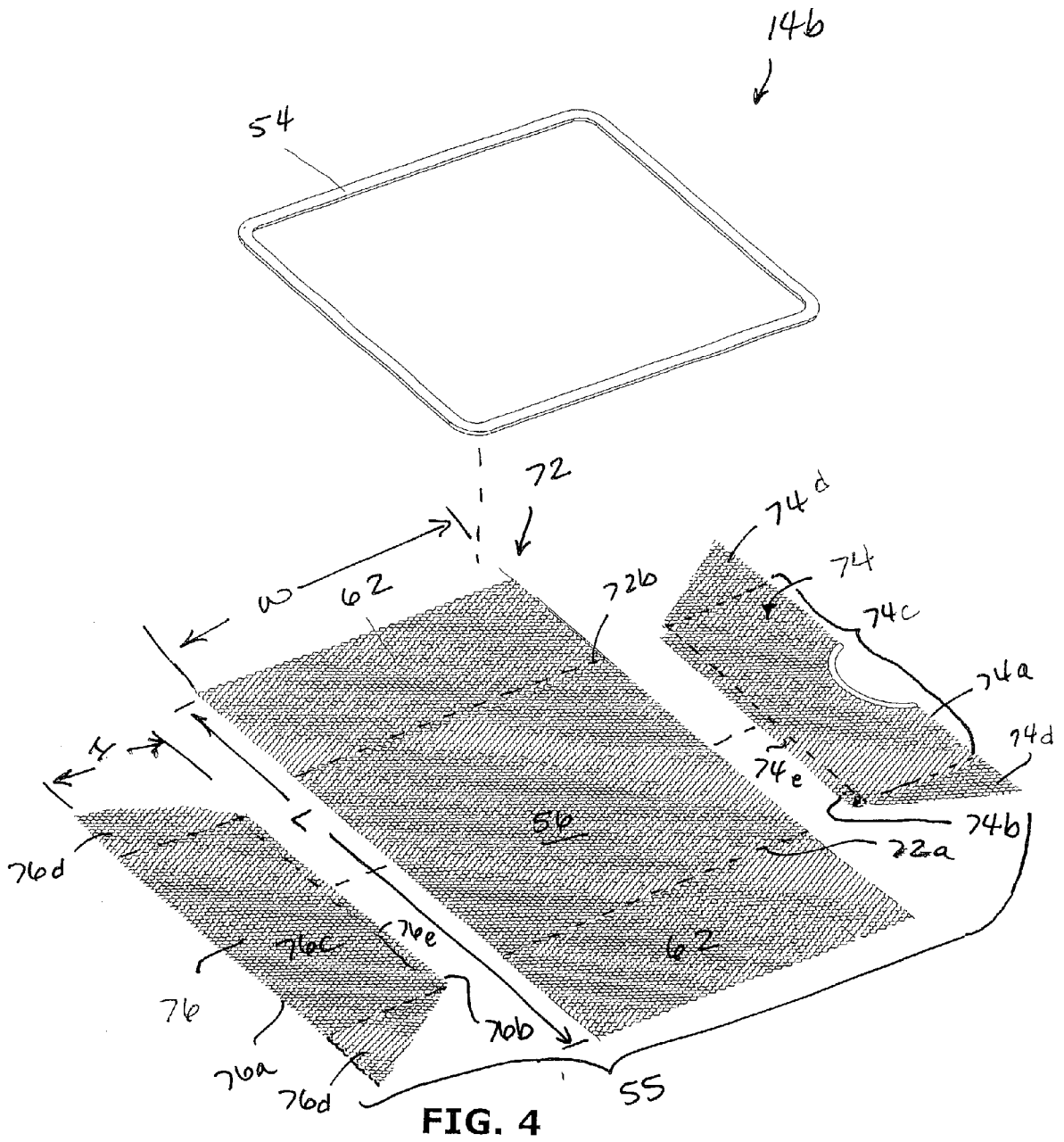

FIG. 3A



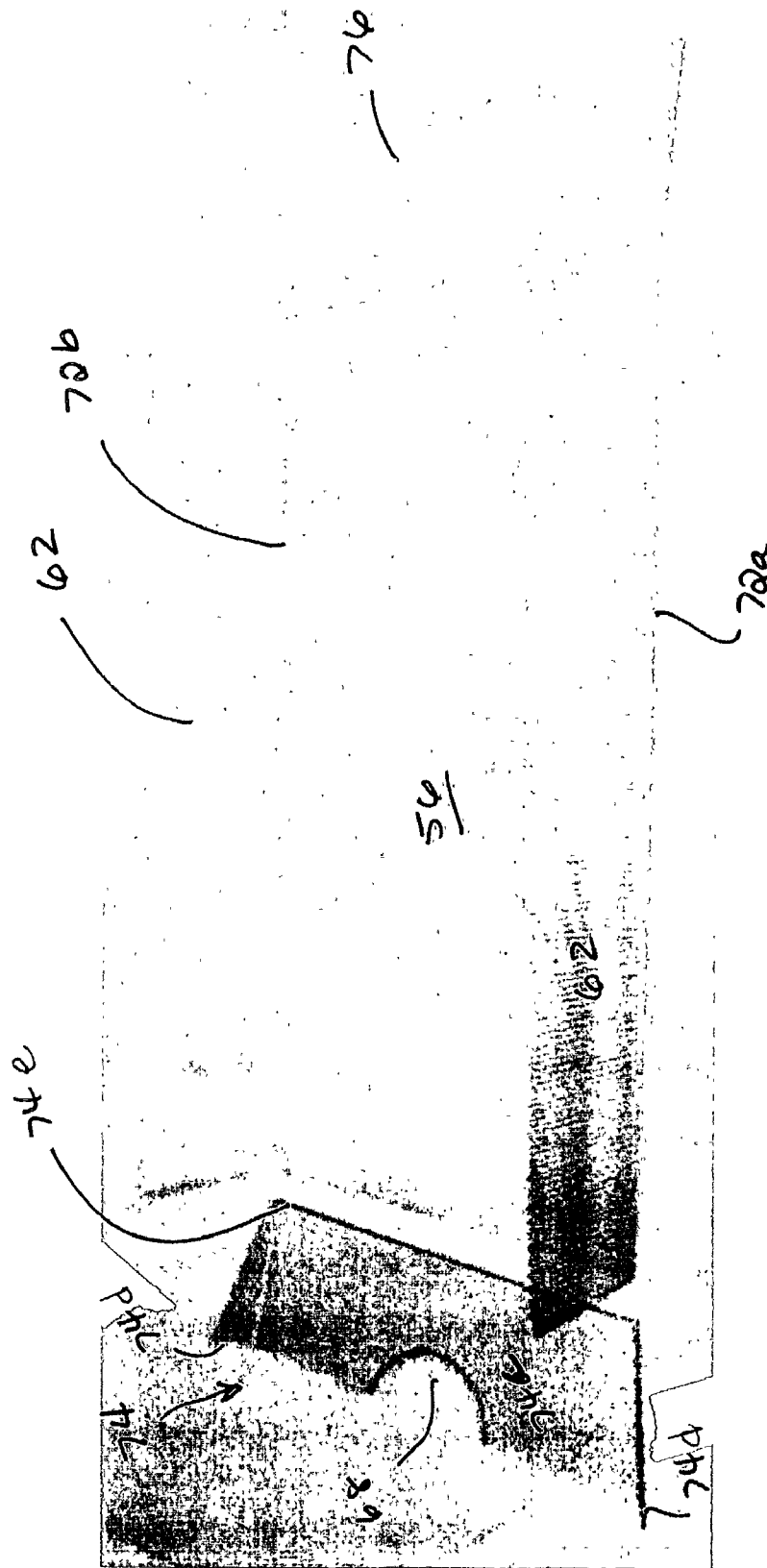
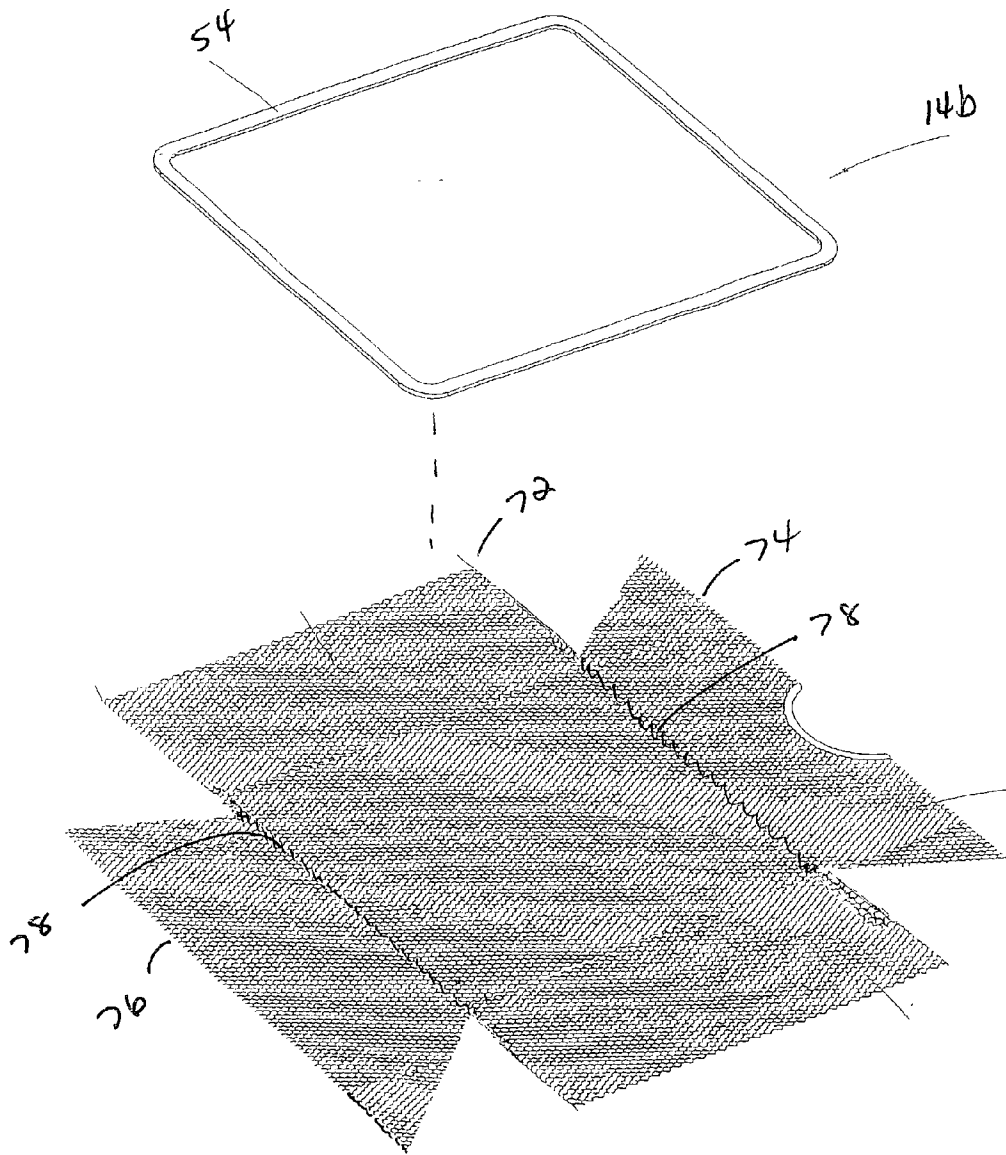

FIG. 5



**FIG. 5A**





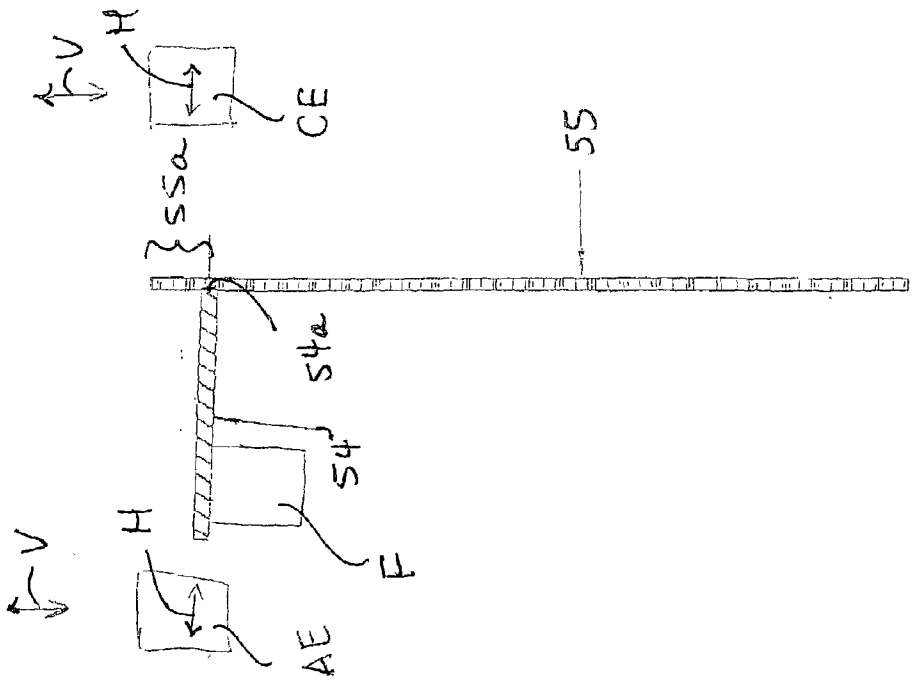

FIG. 8

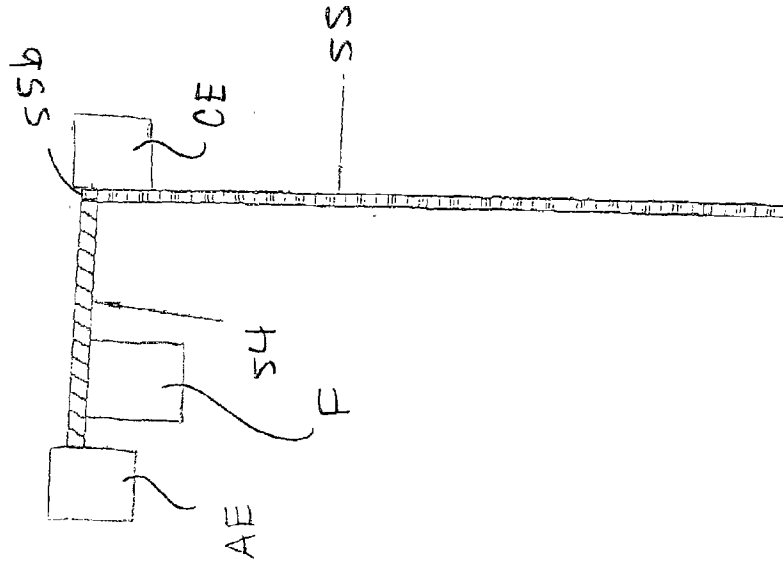

FIG. 9



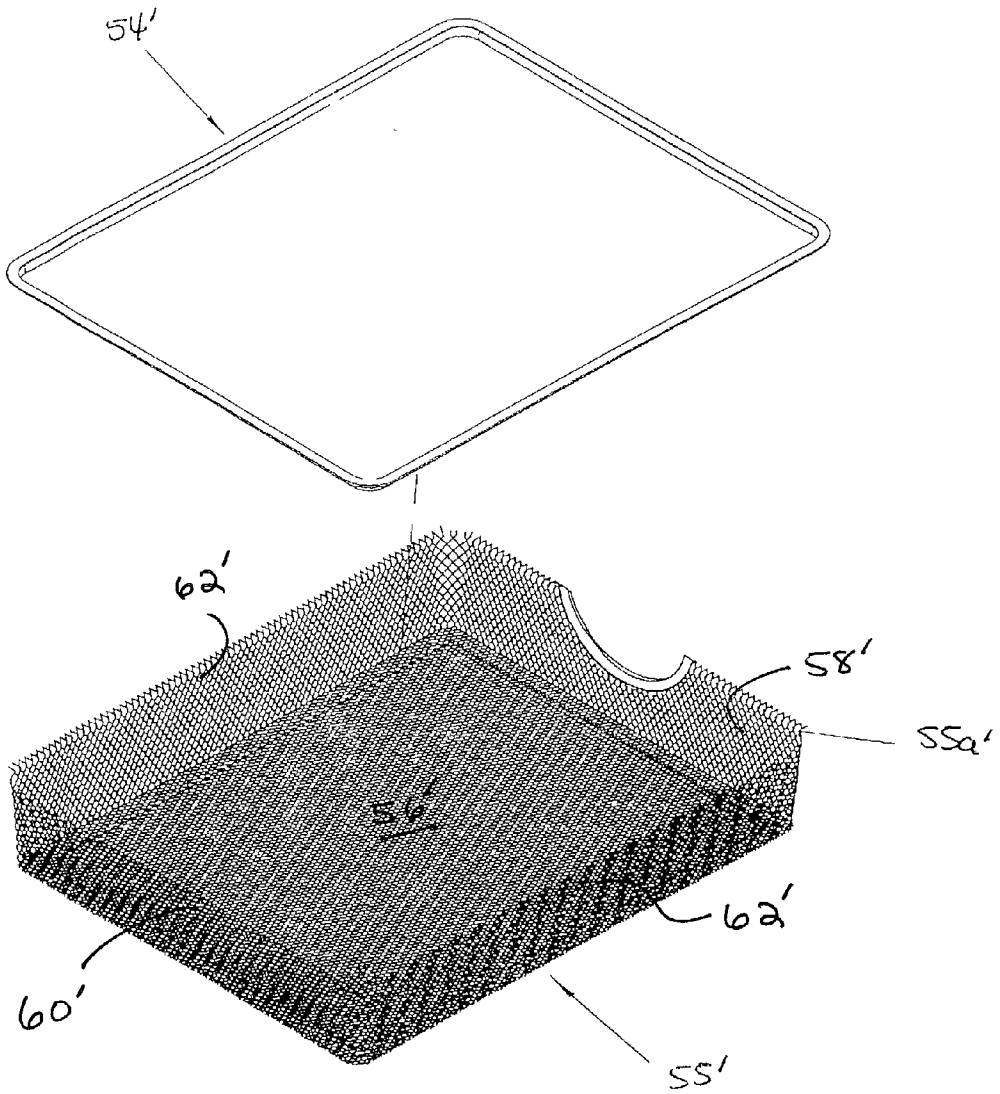
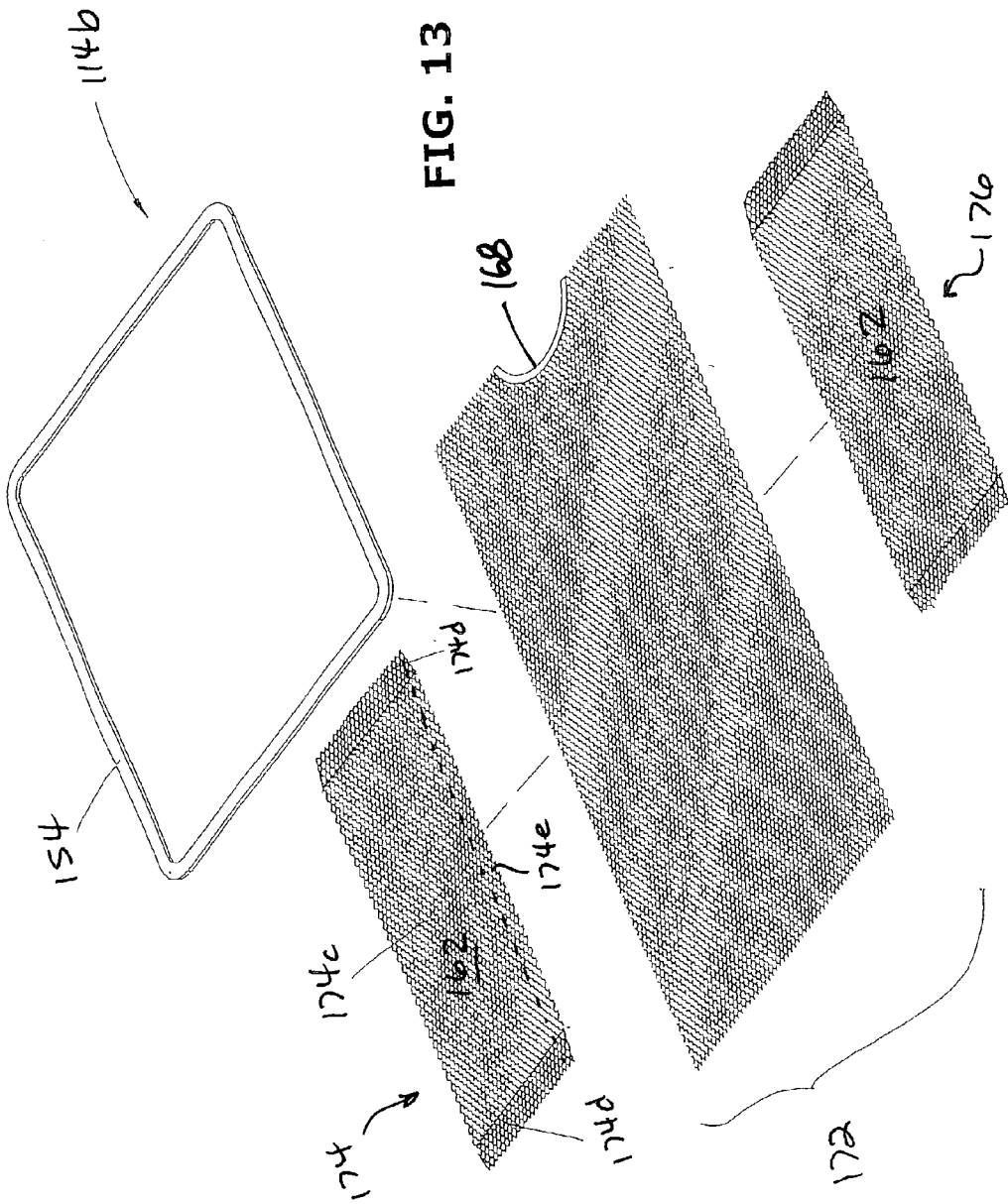
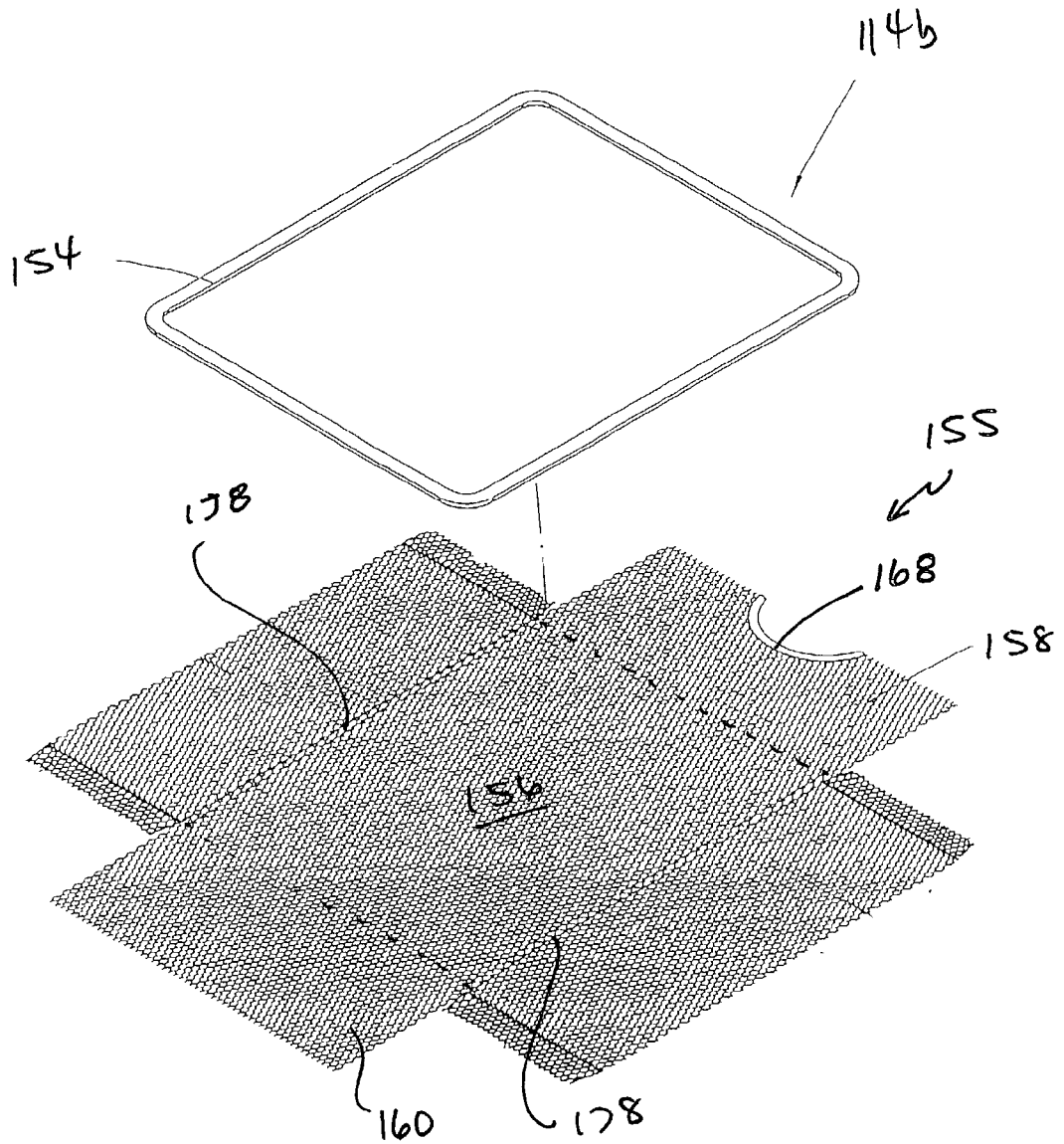

FIG. 12





**FIG. 14**

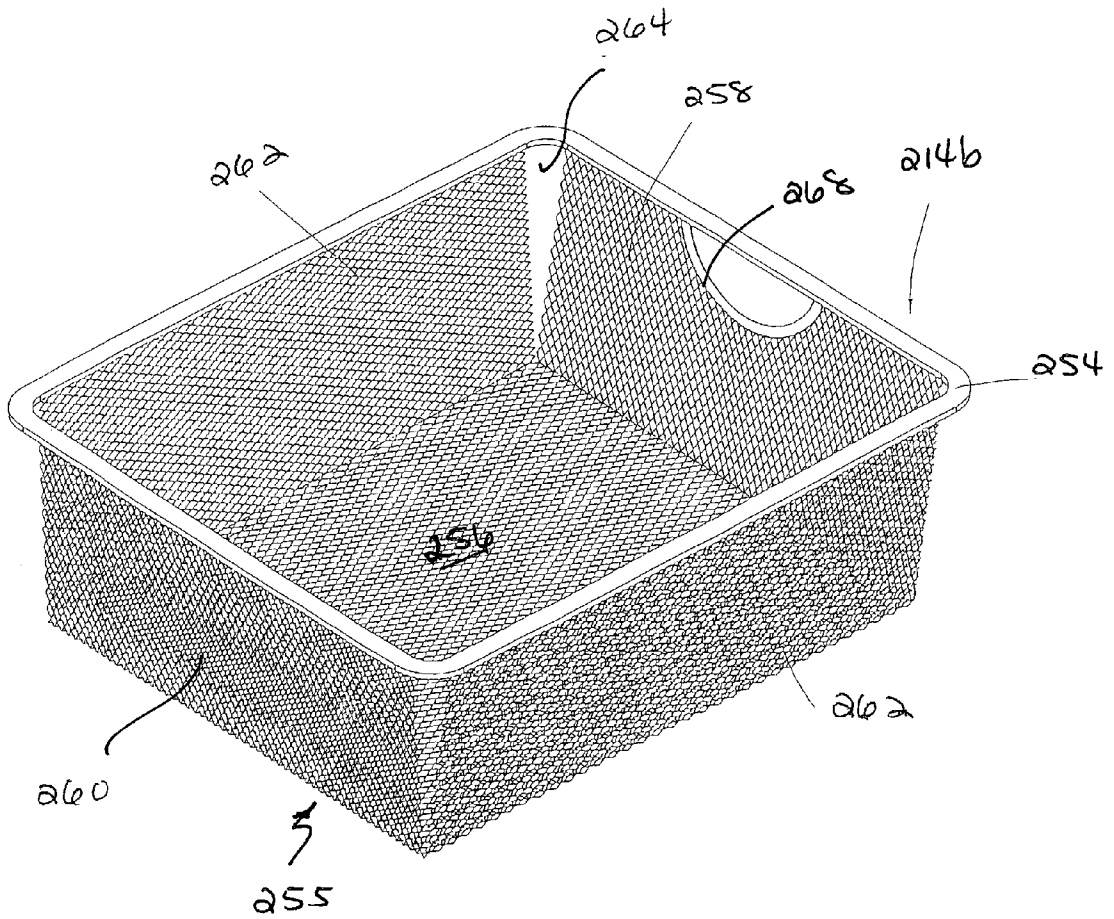
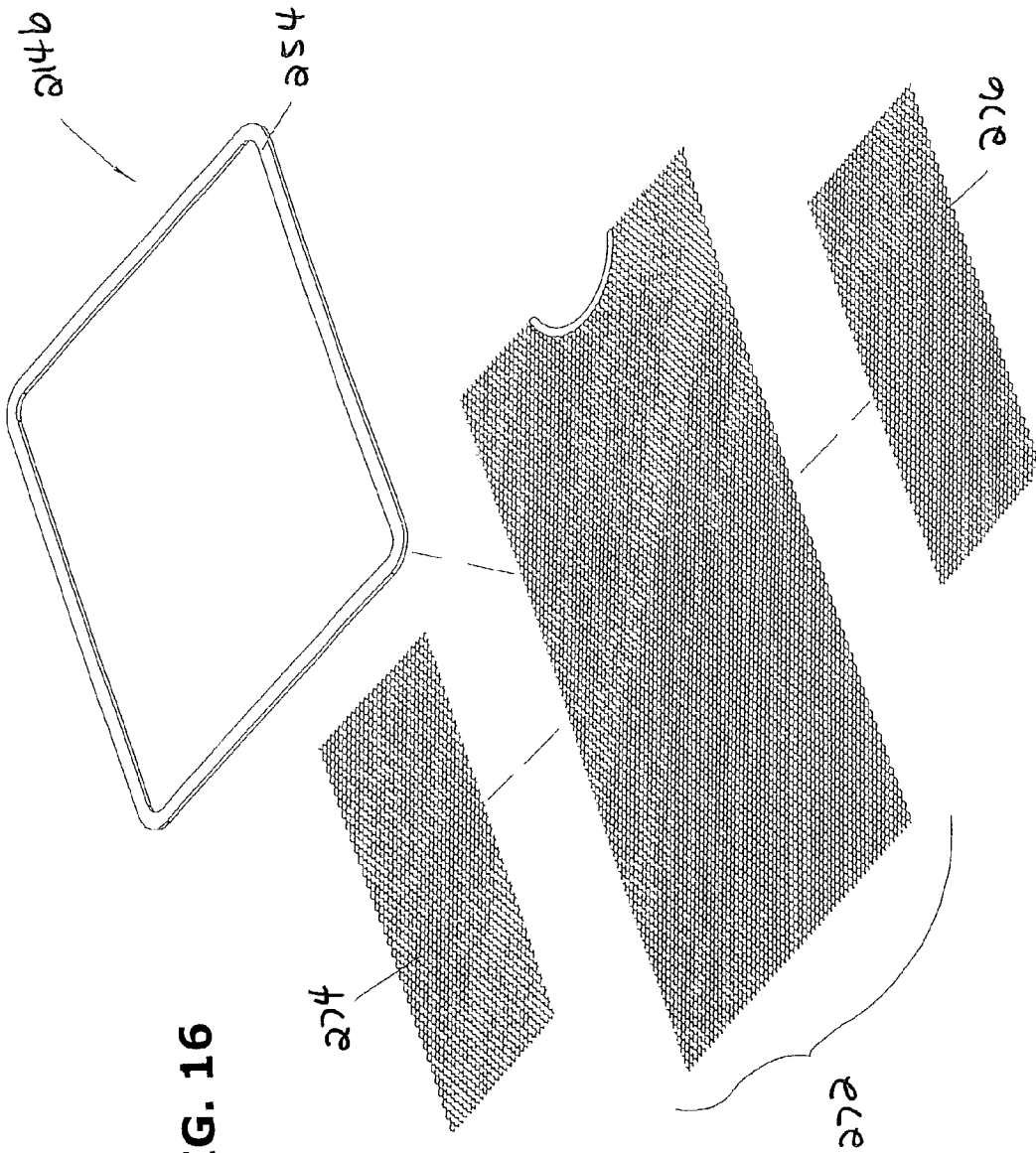

FIG. 15



**FIG. 16**

FIG. 17

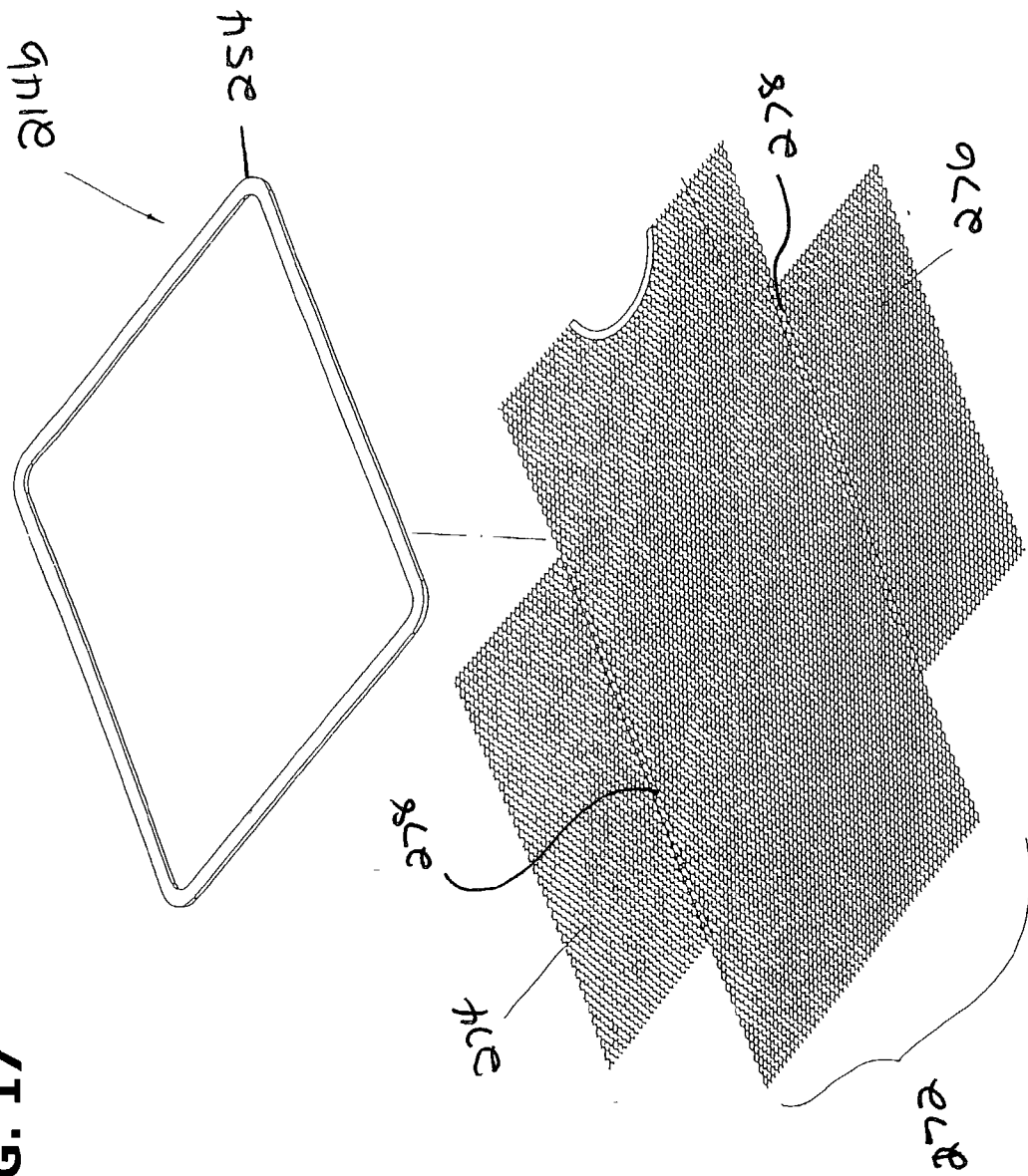
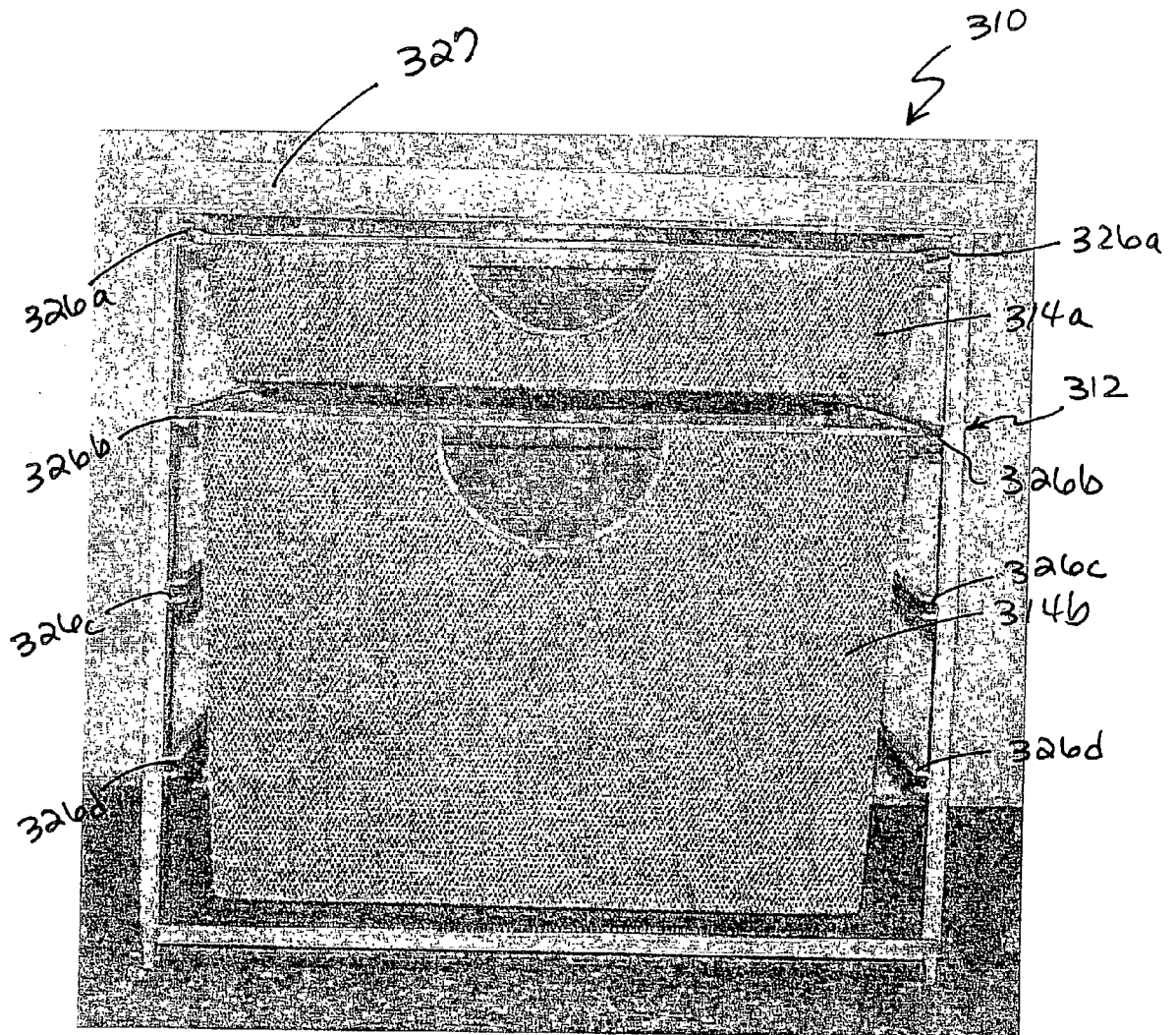



FIG. 18



**MESH CONTAINER, SYSTEM USING MESH  
CONTAINERS AND METHOD FOR MAKING  
MESH CONTAINERS**

**CROSS-REFERENCE TO RELATED  
APPLICATIONS**

[0001] This application claims priority from the prior ROC (Taiwan) Patent Application No. 090220946, filed Dec. 3, 2001; ROC (Taiwan) Patent Application No. 091202306, filed Apr. 16, 2002; and ROC (Taiwan) Patent Application No. 091214244, filed Sep. 11, 2002. These applications are incorporated by reference herein in their entirety.

**BACKGROUND OF THE INVENTION**

[0002] 1. Field of the Invention

[0003] The present invention relates to containers, a system using such containers, and a method of making such containers. More particularly, the present invention relates to drawers made of mesh material.

[0004] 2. Description of Related Art

[0005] Forming containers out of sheet metal is well known. U.S. Pat. Nos. 903,848 to Donnelly and 1,107,014 to Avery disclose such containers. In order to make these containers, a single blank of flat material is cut out and folded with overlapping sections. Sheet metal does not provide desirable characteristics such as drainage and ventilation.

[0006] In an effort to make a well-ventilated container, U.S. Pat. No. 645,344 to White discloses a container formed of perforated sheet metal, wire-netting or another open-work material. The White container is intended to have a folded state and a flat state. This container is designed to be readily knocked down from its folded state to its flat state and to be easily constructed without tools.

[0007] Other patents attempt to make lightweight, drainable and/or ventilated containers. U.S. Pat. No. 1,994,553 to Wolcott discloses one such container of finely woven wire screening. U.S. Pat. No. 2,825,481 to Glenny discloses another such container of finely woven wire screening. In order to make the White, Wolcott and Glenny containers, a single blank of flat woven wire is cut out and folded with overlapping sections.

[0008] Another wire container that is commercially available under the brand name Elfa® is formed of a wire grid with a plurality of separately formed wires welded together. The Elfa® container includes a basket portion and a flat rail around the top edge of the basket portion. The Elfa® baskets are designed for use in a frame having a plurality of pairs of runners. When the baskets are inserted in the frame, the flat rail is supported by a pair of runners and is movable between retracted and extended positions. The wire grid used for the Elfa® basket has large holes measuring about 1 inch by 1 inch. The Elfa® basket also has openings at its corners. If a user desires to store small objects in these baskets, a plastic liner can be used. The liner has a bottom wall and upwardly bendable sidewalls, with slits between the sidewalls to allow for such bending. The open corners of the basket and the slits between the sidewalls of the liner may allow small objects to fall out of the basket, which is undesirable.

[0009] Mesh material is typically formed by perforating or slitting a piece of sheet metal and stretching it. A sheet of mesh material requires less raw sheet metal than a non-mesh piece of sheet metal and a perforated piece of sheet metal. U.S. Pat. No. 1,408,026 to Ochiltree discloses a desk tray or basket formed of "expanded metal" or mesh material. Similar to the previous containers, the Ochiltree container is formed by a single blank of flat material that is cut out and folded.

[0010] ROC (Taiwan) Patent Application No. 086202709 to Chih-Ming, Ko (in transliteration), filed Feb. 21, 1997, discloses a system of containers supported by a frame. The containers are formed of a single piece of mesh with a rim connected thereto. Additionally, the containers do not move with respect to the frame so that the contents of the lower container are not easily accessible.

[0011] A number of mesh containers are made by Design Ideas, Ltd. One of these containers is the "Mesh Storage Nest." This container is formed using a first piece of mesh that has the ends welded together to form a loop. A second piece of mesh is welded to the lower edge of the loop so that the first piece of mesh forms sidewalls and the second piece of mesh forms a bottom wall. The seam at the bottom of the container is covered by a bottom rail. A top rail is connected to the upper edge of the container. The sidewalls can be shaped to include a plurality of corners.

[0012] A need exists for a lightweight container that can be incorporated into a system for storing objects. It is also desirable that the contents of such a container be made easily accessible and be prevented from accidentally falling through holes in the container. Furthermore, it is desirable that the container be formed by an economical method in unlimited sizes. The present invention was developed with the above-noted general objects in mind.

**SUMMARY OF THE INVENTION**

[0013] The present invention is directed to a container or drawer comprising first and second pieces of mesh material. The first piece of mesh forms a bottom wall and two spaced apart first and second sidewalls that extend upwardly from the bottom wall. The second piece of mesh material is formed separate from the first piece of mesh material. The second piece of mesh material includes third and fourth sidewalls. The second piece of mesh material is joined to the first piece of mesh material to form a basket portion. The basket portion may further include a runner portion that may be a rail separately formed from the basket portion.

[0014] In one embodiment, the basket portion includes open corners between the sidewalls. In another embodiment, the third and fourth sidewalls include extensions for overlapping the first and second sidewalls so that closed corners are formed between the sidewalls. In such an embodiment, the corners may be curved.

[0015] Preferably, one drawer and more preferably, a plurality of drawers are useful with a frame in a storage system. Each drawer is moveable with respect to the frame between retracted and extended positions. In such an embodiment, the frame may further include a pair of runners with a gap therein for slidably receiving the runner portion of each drawer.

[0016] The present invention is also directed to a container comprising first, second, and third pieces of mesh material.

The first piece of mesh forms a bottom wall and first and second spaced apart sidewalls that extend upwardly from the bottom wall. The second piece of mesh material is formed separate from the first piece of mesh material. The third piece of mesh material is formed separate from the first and second pieces of mesh material. The second and third pieces of mesh material are joined to the bottom wall by a pair of bottom seams. Additionally, the second and third pieces of mesh material are joined to the end walls by a plurality of generally vertically extending side seams that all combine to form a basket portion.

[0017] The basket portion may further include runner portion. In such an embodiment, the runner portion may be a rail that may be separately formed from the basket portion.

[0018] In one embodiment, the rail is preferably a flat piece of material and can include a curved portion. In the latter rail embodiment, the curved portion defines an opening in an uncompressed state for receiving the upper section of the basket portion, and in a compressed state the opening is minimized.

[0019] The present invention is also directed to a method for forming a container comprising the steps of: forming a first piece of mesh material; bending the first piece of mesh material into a bottom wall and first and second spaced apart sidewalls extending upwardly from the bottom wall; forming at least one second piece of mesh material separate from the first piece of mesh material including forming the second piece of material to include third and fourth sidewalls; and connecting the first piece of mesh material to the second piece of mesh material to form a basket portion with an upwardly-extending opening.

[0020] The method can include the step of forming second and third separate pieces of mesh that will form the third and fourth sidewalls.

[0021] According to one aspect of the inventive method, the connecting steps may be performed by welding.

[0022] The method may further include the step of forming a runner portion on the top of the basket portion.

#### BRIEF DESCRIPTION OF THE DRAWINGS

[0023] The present invention will be more fully appreciated as the same becomes understood from the following detailed description of the best mode presently contemplated for carrying out the present invention when viewed in conjunction with the accompanying drawings, in which:

[0024] FIG. 1 is front, perspective view of a first preferred embodiment of a system of drawers of the present invention, where the drawers are in a retracted position;

[0025] FIG. 2A is an enlarged, perspective view of an L-connector for use with the system of FIG. 1;

[0026] FIG. 2B is an enlarged, end view of the L-connector shown in FIG. 2A;

[0027] FIG. 2C is an enlarged, perspective view of a T-connector for use with the system of FIG. 1;

[0028] FIG. 2D is an enlarged, end view of the T-connector shown in FIG. 2C;

[0029] FIG. 3 is an enlarged, rear, perspective view of a first preferred embodiment of a drawer shown in FIG. 1;

[0030] FIG. 3A is an enlarged, perspective view of a portion of the drawer shown in FIG. 3;

[0031] FIG. 4 is an exploded, rear, perspective view of the drawer shown in FIG. 3;

[0032] FIG. 5 is an exploded, rear, perspective view of a portion of the drawer shown in FIG. 3, wherein all of the mesh pieces have been bent;

[0033] FIG. 5A is a partially-exploded, rear, perspective view of the drawer shown in FIG. 4, wherein three pieces of mesh material have been joined together;

[0034] FIG. 6 is a schematic representation of some of the mesh pieces of FIG. 5 and a portion of a welding machine for joining such pieces;

[0035] FIG. 7 is a schematic representation of some of the mesh pieces of FIG. 5 and another portion of the welding machine of FIG. 6;

[0036] FIG. 8 is a partial, elevational view of a first embodiment of an upper rail joined to one of the mesh pieces shown in FIG. 5, wherein an upper portion of the mesh piece is uncropped;

[0037] FIG. 9 is a partial, elevational view of the upper rail joined to the mesh piece of FIG. 8, wherein the upper portion of the mesh piece is cropped;

[0038] FIG. 10 is a partial, elevational view of a second embodiment of an upper rail separated from a mesh piece;

[0039] FIG. 11 is a partial, elevational view of the upper rail joined to the mesh piece of FIG. 10;

[0040] FIG. 12 is an exploded, rear, perspective view of a second embodiment of a basket using the upper rail and mesh piece shown in FIGS. 10 and 11;

[0041] FIG. 13 is an exploded, rear, perspective view of a third embodiment of a drawer for use in the system of FIG. 1, wherein an alternative embodiment of two side pieces of mesh material are used;

[0042] FIG. 14 is a partially-exploded, rear, perspective view of the drawer shown in FIG. 13, wherein three pieces of mesh material have been joined together;

[0043] FIG. 15 is an enlarged, rear, perspective view of a fourth embodiment of a drawer useful in the system of FIG. 1;

[0044] FIG. 16 is an exploded, rear, perspective view of the drawer shown in FIG. 15;

[0045] FIG. 17 is a partially-exploded, rear, perspective view of the drawer shown in FIG. 15, wherein three pieces of mesh material have been joined together; and

[0046] FIG. 18 is front, perspective view of a second preferred embodiment of a system of drawers of the present invention, where the drawers are shown in a retracted position.

#### DETAILED DESCRIPTION OF THE PREFERRED EMBODIMENTS

[0047] Referring to FIG. 1, a preferred, first embodiment of a drawer system 10 is shown. This drawer system 10 may be used to store a variety of housewares, such as kitchen items, clothing, accessories, sports equipment, shoes, bath-

room supplies, tools, appliances, and the like. Additionally, the system 10 can be used to store a variety of other items, for example food, office supplies, office equipment, file folders, papers/documents, bags, boxes, cans, bottles, etc.

[0048] The drawer system 10 includes a frame 12 and a plurality of containers or drawers 14a-d. The drawer 14a is smaller than the drawers 14b-c so drawer 14a can hold a smaller volume than the other drawers 14b-d. The drawers 14a-d are movable with respect to the frame 12 between a retracted position (shown in FIG. 1) and an extended position. In the retracted position, the contents of the lower drawers 14b-d is difficult to access. In the extended position, the contents of the extended drawer are easily accessible; the extended drawer may be fully withdrawn from frame 12 if desired.

[0049] With reference to FIG. 1, frame 12 includes two side frame members or ladders 16 that are spaced apart and joined by pairs of upper and lower cross members 18a,b, respectively. The side frame members 16 and the pairs of upper and lower cross members 18a,b are formed to give the frame 12 a rectangular shape. The present invention is not limited to this frame shape.

[0050] The frame 12 further includes L-connectors 20 (as best seen in FIG. 2A) and T-connectors 22 (as best seen in FIG. 2B) for joining the side frame members 16 to the cross frame members 18a,b. Preferably, L-connectors 20 connect upper cross member 18a to the side frame members 16, if no additional frames are to be added above the one illustrated in FIG. 1. If an additional frame is to be added above the frame 12 shown in FIG. 1, T-connectors 22 are used to join upper cross members 18a to frame members 16. Preferably, T-connectors 22 also connect lower cross members 18b to the side frame members 16. Alternatively, the T-connectors 22 joined to the lower cross members 18b can be replaced with plugs with casters (not shown) thereon to make the system 10 movable, as is apparent to those of ordinary skill in the art.

[0051] Referring again to FIG. 1, each side frame member 16 includes a pair of spaced apart vertical rods 24 coupled by vertically spaced apart horizontally-extending runners 26a-g. Each side frame member 16 is formed so that the runners 26a-g of each side frame member 16 are aligned with the runners 26a-g of the other side frame member 16 to form a plurality of pairs of runners. Each runner 26a-g is a generally U-shaped member with an inwardly extending gap 28 defined therein. The runners 26a-g may include a bore (not shown) in the rear end for receiving a pin (not shown) for preventing rearward movement of the drawers 14a-d out of the frame 12. To make the frame independent of direction the bore (not shown) may be formed at both ends of each runner and the pin (not shown) disposed in the desired end for use.

[0052] The frame 12 is preferably formed of any metal with sufficient rigidity and formability, for example mild sheet steel, stainless steel, aluminum, copper or the like can be used. The vertical rods 24 and the runners 26a-g are preferably welded together using conventional welding techniques. The frame 12 may be subjected to a powder painting treatment, similar to that discussed below for the drawers 14a-d.

[0053] Referring to FIGS. 1, 2A and 2B, the L-connector 20 includes a central body 30 and first and second generally

perpendicular legs 32 and 34 extending therefrom. Preferably, the pairs of cross members 18a,b and vertical rods 24 are hollow so that the legs 32 and 34 are received therein to join these components together. Referring to FIGS. 1, 2C and 2D, the T-connector 22 includes a central body 36 and first, second, and third legs 38, 40, and 42, respectively, extending therefrom. First and second legs 38 and 40 are generally perpendicular to one another similar to L-connector 20. Third and second legs 40 and 42 are also generally perpendicular to one another. Preferably, the first leg 38 and the third leg 42 may be inserted into the hollow vertical rods 24, and the second leg 40 is inserted in the hollow associated cross members 18a,b.

[0054] The L-connectors 20 and T-connectors 22 are preferably formed of any metal with sufficient rigidity and formability. For example, the connectors 20 and 22 can be cast of die-cast aluminum or any alloy, using conventional techniques known to those of ordinary skill in the art. These connectors 20 and 22, however, can also be formed of another material like injection molded plastic.

[0055] Now, with reference to FIGS. 1, 3, and 3A, the details of the drawer 14b will be discussed. The drawer 14b includes a runner portion that comprises upper rail 54 and a basket portion 55. The basket portion 55 is coupled to the upper rail 54. In the present embodiment, the basket portion 55 is formed of expanded metal plate (i.e., sheet metal) or "mesh" and has small openings 55a therein. In the present specification and appended claims "mesh" means flat metal that is pierced and stretched so that no material is separated from the original raw material, as known by those of ordinary skill in the art. On the other hand, unlike mesh, punching portions of waste material out of sheet metal forms perforated metal. Preferably, the openings 55a (see FIG. 3) in the mesh have an area less than 25.4 mm by 25.4 mm, more preferably less than 20 mm by 10 mm, and most preferably, less than 6 mm by 3 mm.

[0056] The basket portion 55, preferably, is formed of any metal such as copper, steel, stainless steel or aluminum, and the like. The basket portion 55 includes a bottom wall 56, a pair of spaced apart sidewalls 58 and 60, and another pair of sidewalls 62. Preferably, the sidewalls 58, 60 and 62 are joined together to form closed curved corners 64. The sidewalls 58, 60 and 62 extend upwardly from the bottom wall 56 to form an upwardly-facing opening 66.

[0057] As shown in FIG. 3, the corners 64 are curved so that they deviate from straightness in a smooth, continuous fashion. The present invention, however, is not limited to drawers with curved corners and drawers with more angular corners are also considered inventive. The present invention is also not limited to drawers with a radius of curvature greater at the top of the drawer (adjacent the rail 54) than at the bottom. Thus, drawers with, for example, a constant radius of curvature are also considered inventive.

[0058] In this embodiment, the sidewall 58 forms a front end wall that includes a curved cutout 68 bordered by a handle rail 70. The cutout 68 forms a place where a user can easily grasp the drawer 14b to move it between the retracted and extended positions. In an alternative embodiment, the cutout 68 can be replaced with other methods to aid the user in moving the drawer 14b, such as a protruding handle connected to wall 58. The handle rail 70 may have a circular cross-sectional shape and be cut and formed to extend along

the edge of cutout 68. Preferably, the rail 70 is of the same material as upper rail 54 and is spot-welded to the basket portion 55. In this embodiment, the sidewall 60 forms a rear end wall.

[0059] Referring to FIG. 4, the drawer 14b is shown in a disassembled state. The basket portion 55 is formed by a first piece of mesh 72, a second piece of mesh 74 and a third piece of mesh 76. The first, second, and third pieces of mesh are formed separately from one another. The first piece of mesh 72 is bent along lines 72a,b to form edges as shown in FIG. 5 to define bottom wall 56 and sidewalls 62. The angle between the bottom wall 56 and sidewalls 62 is greater than about 90°, but the present invention is not limited to this configuration.

[0060] The second piece of mesh 74 includes an outer edge 74a, an inner edge 74b, a central portion 74c, side extensions 74d, and a lower extension 74e. The central portion 74c is between the outer edge 74a and the lower extension 74e and between the side extensions 74d. The side extensions 74d have a trapezoidal shape so that they taper downward from the outer edge 74a to the lower edge 74b. The second piece of mesh 74 is bent to form front end wall 58, curved corners 64, and lower extension 74e that is generally perpendicular to front end wall 58 (see FIGS. 3 and 5). Third piece of mesh 76 is formed similarly to second piece of mesh 74 to include an upper edge 76a, a lower edge 76b, a central portion 76c, side extensions 76d, and a lower extension 76e.

[0061] In an alternative embodiment, the pieces of mesh 74 and 76 can be formed of a single piece of material separate from the first piece of mesh 72. In such event, the two pieces of mesh 74 and 76 would be joined by another mesh segment (not shown) that would be shaped similar to bottom wall portion 56. As a result, the bottom wall of basket 55 would be formed of two layers of mesh material that overlap.

[0062] Referring to FIG. 5A, the first, second, and third pieces of mesh 72, 74, and 76 have been joined together so that bottom seams 78 are formed. Seams 78 are where the material of bottom wall 56 of the first piece of mesh 72 overlaps with lower extension 74e of the second and third pieces of mesh 74 and 76 (see FIG. 4). When the corners 64 are formed, side seams 80 (as shown in FIG. 3) are formed adjacent each corner 64. Seams 80 are where the material of sidewalls 62 of the first piece of mesh 72 overlaps with side extensions 74d and 76d of second and third pieces of mesh 74 and 76, respectively. Seams 80 are generally vertically extending side seams.

[0063] The method of making drawer 14b will now be discussed. Referring to FIGS. 4 and 5, the first piece of mesh 72 is formed shaped as shown. This involves cutting a piece of mesh 72 with the desired dimensions from a roll of mesh using a conventional press machine. Then, the first piece of mesh 72 is bent into a U-shape that includes the bottom wall 56 and end walls 62 (as shown in FIG. 5). A conventional hydraulic press machine is used to bend the mesh piece 72. The hydraulic press machine includes a mold for achieving the desired bent shape, as is known by those of ordinary skill in the art.

[0064] The second and third pieces of mesh 74 and 76 are formed and shaped as shown in FIG. 4. This involves

cutting the pieces of mesh 74 and 76 with the desired dimensions and shape from a roll of mesh using a conventional press machine. Then, the piece 74 is bent using a conventional hydraulic press machine so that side extensions 74d are curved and lower extension 74e is angularly offset from center section 74c. The hydraulic press machine includes a mold, as is known by those of ordinary skill in the art. The third piece of mesh 76 is bent similarly to second piece 74 (as shown in FIG. 5). The handle rail 70 may be welded to mesh piece 74 at this point or later, when the upper rail 54 is joined to basket portion 55.

[0065] After the drawer 14b is completely formed, optionally but preferably a process of powder painting may be used to coat the drawer 14b, as is known by those of ordinary skill in the art. One preferable paint is an epoxy coat. The painting may provide a decorative (colored and/or metallic) finish to the drawer 14b, if desired, and will also provide some protection for the drawer 14b from water and other corrosive elements.

[0066] Next, the lower extensions 74e,76e of each piece 74,76 are connected by welding to the side edge of the bottom wall 56 of first piece 72 (as shown in FIG. 5A) to form seams 78. Then, the curved side extensions 74d,76d of pieces 74,76 are connected by welding to sidewalls 62 of first piece 72 to form seams 80 (as shown in FIG. 3).

[0067] Referring to FIGS. 5, 6, and 7, the equipment used to connect the first, second and third pieces of mesh 72, 74, and 76 together will now be discussed. The equipment preferably comprises a spot-welding machine 84 including a base 86, a clamp 88 supported on the base 86, a movable elongated member 90 movable by the clamp 88 to provide a clamping force F, and a pair of anode electrodes 92a and a pair of cathode electrodes 92b. The base 86, clamp 88, member 90, and cathode electrodes 92b form a fixture for supporting the mesh pieces 72, 74, and 76 during welding. As shown, preferably, the cathode electrodes 92b are preferably bar-like and parallel to one another to properly support and clamp mesh pieces 72, 74, and 76. In an alternative embodiment, the spot-welder can be used without the clamp 88 and elongated member 90, where the pieces may be manually held during welding.

[0068] In order to join lower extension 74e of second piece 74 to bottom wall 56 of first piece 72, the already-bent first piece 72 is disposed on cathode electrodes 92b so that the sidewalls 62 extend downward (as shown in FIG. 6) toward the floor. Bent second piece 74 is disposed between member 90 and cathode electrode 92b, as shown in FIG. 7. Next, the clamp 88 is actuated so that the clamping force F moves the member 90 from a retracted position (shown in FIG. 6) into a clamping position (shown in FIG. 7). In the clamping position, the mesh piece 74 is compressed between member 90 and cathode electrode 92b. The clamping force F must be sufficient to hold mesh piece 74 into contact with mesh piece 72 for the welding operation.

[0069] Then, the anode electrode 92a moves in direction D1 into contact with pieces 72,74 adjacent extension 74e. These pieces 72,74 are tightly compressed between the electrodes 92a and 92b. The electrodes 92a,b then discharge electric welding current through the place to be welded and seam 78 (see FIG. 5A) is formed. The third piece 76, as shown in FIG. 5, is similarly joined to first piece 72. Preferably, the welding machine 84 is properly configured so

that the fixture includes two clamps, two elongated members **90** and two pairs of electrodes **92a,b**. As a result, the second and third pieces **74** and **76** can preferably be simultaneously welded to first piece **72**.

[0070] Another spot-welding machine similar to machine **84** is used to weld pieces **74** and **76** to piece **72** adjacent the corners **64** to form seams **80**. This spot-welding machine for forming seams **80** has an appropriately sized fixture including clamp(s), elongated member(s) and cathode electrode(s) for smaller pieces **74** and **76**. For example, the cathode electrode(s) may be tapered to match trapezoidal extensions **74d,76d** so that pieces **74** and **76** are suitably clamped to end walls **58** and **60** during welding.

[0071] With reference to **FIG. 3**, the upper rail **54** is subsequently connected to the upper section of the end walls **58** and **60** and sidewalls **62** by spot-welding. Referring to **FIGS. 3 and 8-9**, the step of connecting the upper rail **54** to the basket portion **55** further preferably includes the steps of forming a generally flat upper rail **54**; contacting rail **54** to basket portion **55** on a contact surface **54a** so that an upper section **55a** of the basket portion **55** extends above the rail **54**; and spot-welding the contact surface **54a** to the outer surface of basket portion **55**.

[0072] The upper rail **54** is preferably formed of the same material as the basket portion **55** so that these components can be welded together. Thus, preferably, the rail **54** is formed of any metal such as copper, steel, stainless steel, mild sheet steel or aluminum, and the like. In a preferred embodiment using sheet steel, a roll of sheet steel strip material with a circular cross-section is used. This material is passed through a conventional roll forming machine with a number of pairs of rollers using a predetermined compression pressure to continuously and gradually change the circular cross-section into a generally flat rectangular cross-section, as is known by those of ordinary skill in the art.

[0073] The material with the flat rectangular cross-section is then fed into a bending machine that includes spaced apart pairs of guide rollers for guiding the material through the machine and bending the material into four spaced apart right angles to form a rectangular ring. Hydraulic power can be used to provide the bending force to the associated pairs of guide rollers. Where the bending pairs of guide rollers are located, the machine further includes rollers for preventing vertical expansion of the material. Once the rectangular ring is formed, the free ends of the ring are joined by welding to form the upper rail **54**.

[0074] The rail is not limited to the above configuration, shape and materials. For example, it can be hollow with various shapes, such as a circular cross-section. The rail can also be solid with various shapes, such as a circular cross-section. The rail can also be formed of a plastic that is connected to the basket portion **55** by glue or adhesive, for example.

[0075] Referring to **FIGS. 8 and 9**, the step of contacting rail **54** to basket portion **55** on a contact surface **54a** may preferably further include the step of using a spot-welding machine with a fixture **F** for supporting the rail **54** at a sufficient elevation above a table (not shown) so that the upper section **55a** of the basket portion **55** extends above the rail **54**. The fixture **F** may also provide a clamping force for assuring the surface **54a** is in solid contact with the basket

portion **55** or this force may be provided by movable anode and cathode electrodes **AE** and **CE**, respectively. Preferably, electrodes **AE** and **CE** are circular welding wheels. The anode electrode **AE** contacts the outer surface of the rail **54** and the cathode electrode **CE** contacts the inner surface of the basket portion **55** adjacent surface **54a**, as shown in **FIG. 9**. An electric current is discharged through the electrodes **AE** and **CE**, rail **54** and basket portion **55** to spot-weld the rail **54** to the basket portion **55**. Preferably, sufficient electrodes **AE** and **CE** are provided to make the welding of rail **54** to basket portion **55** efficient. Since the electrodes **AE** and **CE** are movable vertically in directions **V** and horizontally in directions **H**, the spot-welder can be used to weld variously size rails and baskets together.

[0076] The step of connecting the upper rail **54** may further include cutting and grinding steps. In the cutting step, the upper section **55a** (as shown in **FIG. 8**) of basket portion **55** is severed using a conventional severing apparatus, such as one including a reciprocating saw blade. In the grinding step, the exposed upper edge **55b** (**FIG. 9**) of basket portion **55** is worked using a conventional grinding machine so that a smooth upper edge **55b** is formed. The rail **54** aids in providing structural rigidity to the basket portion **55** and is the only rail circumscribing each drawer's perimeter.

[0077] Referring to **FIGS. 1 and 3**, in use the drawer **14b** is inserted into the system **10** by disposing upper rail **54** within gap **28** of opposed, aligned pair of runners **26b**. The rail **54** and gap **28** are sized to allow free sliding movement of the drawer **14b** with respect to the frame **12** between the retracted and extended positions.

[0078] Since the drawer **14b** is formed of mesh with very small openings **55a** (see **FIG. 3**), small objects, such as pens, paper clips, and the like, can be stored in the drawer without a liner and will not fall through the openings **55a**. In addition, since the drawer **14b** has closed corners **64**, small objects also cannot fall out of this area of the drawer.

[0079] As shown in **FIG. 1**, drawers **14b-14d** are of medium size and vertically extend across two sets of vertically spaced runners. Drawer **14a** is a small size and consequently extends across only one set of vertically spaced runners. The drawers may be sized differently, see **FIG. 4**, particularly by changing the length **L** of the first piece of mesh **72** and the height **H** of the second and third pieces of mesh **74** and **76**. This allows containers of a variety of sizes to be formed without excess machinery costs, particularly large containers having a depth **D** from bottom wall **56** to top surface of top rail **54** (see **FIG. 3**) equal to or greater than about 11 inches. If larger baskets are desired, the basket material may need to be changed and/or thickened to provide more rigidity thereto. The width **W** of the mesh (**FIG. 4**) can be set by the machine forming the raw material so that the edges of piece **72** that will be connected to pieces **74** and **76** are smooth and require no cutting or grinding.

[0080] **FIGS. 10-12** illustrate an alternative embodiment of the upper rail **54'** for use with an alternative embodiment of basket portion **55'**. To form the upper rail **54'** raw material is bent to include a curved portion **54a'** with an opening **54b'** and an extension **54c'** angularly offset from curved portion **54a'** using a roll forming machine. The material is bent into a closed rectangular loop and welded together, similar to rail **54**.

[0081] The basket portion **55'** is formed similarly to basket portion **55** except the end walls **58**, **60** and sidewalls **62** all

have an outwardly bent upper section **55a'** formed by a conventional hydraulic press machine with a mold at the same time other bends are formed in pieces **72, 74, 76** (see **FIG. 5**).

[0082] The bent upper section **55a'** is inserted into the opening **54b'** of the upper rail **54'** (as shown in **FIG. 11**). The curved portion **54a'** is then compressed by a conventional press machine so that the opening **54b'** is minimized and curved portion **54a'** tightly engages the basket portion **55a'**. This step also results in the front curved tip **54d'** of the rail **54'** engaging the angled corner **55b'** of the basket portion **55'**. Then, the vertically-extending extension **54c'** is welded to the basket using a spot-welding machine and fixture similar to the method used for rail **54** (shown in **FIGS. 8 and 9**). Once the upper rail **54'** is joined to basket portion **55'** in this manner, it provides additional structural rigidity to the basket portion **55'**. Using the rail **54'** eliminates the need to cut the upper section **55a** of basket portion **55** as when using rail **54**, as shown in **FIGS. 8 and 9**. Consequently, rail **54'** eliminates the need to deburr the basket portion **55'**.

[0083] Referring back to **FIG. 1**, basket **14a** includes a rectangular cutout **68'** on the front of wall **58'**. A metal handle rail **70'** covers the free end of the mesh within the cutout **68'**. The handle rail **70'** is preferably formed similar to rail **54'** with an opening that is compressed about the mesh, once the mesh is inserted therein. Preferably, the handle rail **70'** also includes an extension, similar to extension **54c'** of rail **54'**, that can be spot-welded to securely attach the rail **70'** to the mesh. In such an embodiment, the opening in the rail **70'** extends vertically along with the extension. In an embodiment of the handle rail **70'** without such an extension, the rail **70'** may still be spot-welded to the mesh.

[0084] Referring to **FIGS. 13-14**, a third preferred drawer embodiment **114b** is shown. Drawer **114b** comprises a runner portion or upper rail **154** and a basket portion **155**. The upper rail **154** may be formed like rail **54** or rail **54'** previously discussed. The basket portion **155** includes a bottom wall **156**, end walls **158** and **160**, and sidewalls **162**. The bottom and end walls **156** and **158** are also sidewalls. A first piece of mesh **172** is bent to form the bottom wall **156** and end walls **158** and **160**. The sidewalls **162** are formed of separate second and third pieces of mesh **174** and **176**, respectively. The end wall **158** includes a first piece of mesh **172** with a cutout **168** similar to end wall **58**.

[0085] For drawer **114b**, different from drawer **14b**, the second piece of mesh **174** includes a central portion **174c**, rectangular side extensions **174d** and a lower extension **174e**. The third piece of mesh **176** has a similar configuration. When the pieces **172, 174** and **176** are connected using a method similar to that used in forming drawer **14b**, the drawer **114b** has closed smoothly curved corners similar to corners **64** (as shown in **FIG. 3**), but the corners of drawer **114b** will have a substantially constant radius. Drawer **114b** also includes four side seams **80** at each corner and two bottom seams **178**.

[0086] Referring to **FIGS. 15-17**, a fourth preferred drawer embodiment **214b** is shown. Drawer **214b** comprises a runner portion or upper rail **254** and a basket portion **255**. The upper rail **254** may be formed like rail **54** or rail **54'** discussed above. The basket portion **255** includes a bottom wall **256**, end walls **258** and **260**, and sidewalls **262**. The end

walls **258** and **260** are also sidewalls. A first piece of mesh **272** is bent to form the bottom wall **256** and end walls **258** and **260**. The sidewalls **262** are formed of separate second and third pieces of mesh **274** and **276**. The end wall **258** includes a cutout **268** similar to end wall **58**.

[0087] In drawer **214b**, different from drawers **14b** and **114b**, the second and third pieces of mesh **274** and **276** do not include extensions. When the pieces **272, 274** and **276** are connected using the method of forming drawer **14b**, pieces **274** and **276** only overlap piece **272** on the bottom not on the sides. As a result, the drawer **214b** has open corners **264** (as shown in **FIG. 15**) and two bottom seams **278**. Drawers configured like drawer **214b** can be used in systems like system **10** (shown in **FIG. 1**) and move between extended and retracted positions. Drawers similar to drawer **214b** can come in a number of sizes. The drawer **214b** is formed similarly to drawer **14b** by bending and spot-welding the mesh pieces.

[0088] Referring to **FIG. 18**, a second preferred embodiment of a drawer system **310** is shown. Drawer system **310** includes a frame **312** and a plurality of drawers **314a** and **314b**. The frame **312** includes four pairs of runners **326a-d**. This embodiment illustrates that any number of pairs of runners can be used depending on how large a system is desired. The frame **312** is otherwise configured and formed similarly to frame **12** (shown in **FIG. 1**). The system **310** further may include a solid table top or shelf **327** that is securely connected to the top of frame **312** by a press fit so that objects can be stored or displayed thereon. Alternatively, the shelf **327** may be sized differently (larger or smaller than) the frame **312** and connected to the frame **312** with conventional fasteners such as screws and L-brackets. Drawer **314a** is small and extends across one pair of runners **326a**. Drawer **314b** is large and extends vertically across three pairs of runners **326b-d**. Drawers **314a** and **314b** are configured and manufactured similar to drawer **14b** (see **FIG. 1**), but drawers configured like drawers **114b** and **214b** can also be used with system **310**.

[0089] Those skilled in the art will appreciate that the conception, upon which this disclosure is based, may readily be utilized as a basis for designing other products for carrying out the several purposes of the present invention. It is important, therefore, that the claims be regarded as including such equivalent constructions insofar as they do not depart from the spirit and scope of the present invention as defined in the appended claims. Therefore, this invention is not to be limited to the specifically preferred embodiments depicted therein. For example, the features of one embodiment disclosed above can be used with the features of another embodiment. Furthermore, the two different runner portions or upper rail embodiments **54** and **54'** can be used exclusively in different systems of drawers to provide systems that cost different amounts, e.g., a high-priced system and a lower priced system. Alternatively, one system can have drawers with both types of rails **54** and **54'**. Additionally, a system can use all closed-corner drawers or combine closed-corner drawers with open-corner drawers in one system. The system may be used with sliding drawers and/or stationary and sliding shelves each supported by a pair of runners. The system frame may also include a section for holding hanging file folders and one or more of the inventive drawers. The drawers of the present invention may be used without a frame. In yet another alternative embodiment, the

containers/drawers of the present invention may be retained within a frame formed of wood, plastic, metal, or material with a wood finish, where the frame has components such as runners and rollers thereon. The frame would cooperate with a stationary holder with runners and rollers thereon so that the container does not move with respect to the holder, but when the holder moves between an extended and retracted position by moving with respect to the stationary component, the container likewise moves. In such an embodiment, the runner portion serves to connect the container to the holder without a sliding engagement therebetween. In addition, the container can be formed without upper rail 54 (see FIG. 3) by forming the runner portion in another way, such as by folding the upper edge of the basket portion upon itself to form a sufficiently-rigid integral runner portion. Alternatively, the runner portion need not extend around the entire basket and may extend only on the sides to work with the runners 26a-g (See FIG. 1). In such an embodiment, the end walls without the runner portions may have upper edges finished with portions of metal, wood, plastic or some other suitable material. Thus, the details of the present invention as set forth in the above-described preferred embodiments should not limit the scope of the present invention.

[0090] Further, the purpose of the Abstract is to enable the U.S. Patent and Trademark Office, and the public generally, and especially the designers and practitioners in the art who are not familiar with patent or legal terms or phraseology, to determine quickly from a cursory inspection the nature and essence of the technical disclosure of the application. The Abstract is neither intended to define the invention of the application, which is measured solely by the claims, nor is intended to be limiting as to the scope of the invention in any way.

We claim as our invention:

1. A container comprising:
  - a first piece of mesh material forming a bottom wall and first and second spaced apart sidewalls extending upwardly from said bottom wall; and
  - a second piece of mesh material formed separate from said first piece of mesh material, said second piece of mesh material including third and fourth sidewalls, said second piece of mesh material being joined to said first piece of mesh material to form a basket portion.
2. The container of claim 1, wherein said basket portion includes open corners between said first and second sidewalls and said third and fourth sidewalls.
3. The container of claim 1, wherein said third and fourth sidewalls each include extensions for overlapping said first and second sidewalls and for forming closed corners between said third and fourth sidewalls and said first and second sidewalls.
4. The container of claim 3, wherein said closed corners are curved.
5. The container of claim 1, wherein said basket portion further includes a runner portion at the top thereof.
6. The container of claim 5, for use with a frame, said container being moveable with respect to said frame between retracted and extended positions.
7. The container of claim 6, wherein said frame further includes a pair of runners each having a gap therein for slidably receiving said runner portion.

8. The container of claim 5, wherein said runner portion is a rail separately formed from said basket portion and welded thereto.

9. The container of claim 5, wherein said runner portion extends about the entire perimeter of said basket portion.

10. A container comprising:

a first piece of mesh material forming a bottom wall and first and second spaced apart sidewalls extending upwardly from said bottom wall;

a second piece of mesh material formed separate from said first piece of mesh material; and

a third piece of mesh material formed separate from said first piece of mesh material; said second and third pieces of mesh material being joined to said bottom wall to form a pair of bottom seams and said second and third pieces of mesh material being joined to said first and second sidewalls to form a plurality of generally vertically-extending side seams, said first, second and third pieces of mesh material being joined to form a basket portion.

11. The container of claim 10, wherein said basket portion further includes a runner portion.

12. The container of claim 11, wherein said basket portion further includes an upper section bent to extend outwardly from the remainder of said basket portion, said runner portion comprising a rail having a curved portion defining an opening for receiving said upper section of said basket portion.

13. The container of claim 12, wherein said rail further includes a rail extension angularly offset from said curved portion, said rail extension being welded to said basket portion after said curved portion is compressed.

14. A method of forming a container comprising the following steps:

forming a first piece of mesh material;

bending said first piece of mesh material into a bottom wall and first and second spaced apart sidewalls extending upwardly from said bottom wall;

forming a second piece of mesh material, separate from said first piece of mesh material, to include third and fourth sidewalls; and

connecting said first piece of mesh material to said second piece of mesh material to form a basket portion with an upwardly-extending opening.

15. The method of claim 14, furthering including the steps of forming a third piece of mesh material separate from said first and second pieces of mesh material, wherein said steps of forming said second and third pieces of mesh material include the steps of forming each of said second and third pieces of mesh material with a central portion and a pair of mesh extensions on both sides of said central portion and bending said extensions to be angularly offset from said central portion.

16. The method of claim 15, furthering including the steps of overlapping said mesh extensions with said first and second sidewalls and connecting said mesh extensions to said first and second sidewalls.



**17.** The method of claim 14, wherein the step of connecting said first piece of mesh material to said second piece of mesh material further includes the step of welding.

**18.** The method of claim 14, further including forming a runner portion on the top of said basket portion.

**19.** The method of claim 18, wherein the step of forming said runner portion further includes the step of forming a rail separate from said basket portion and connecting said rail to said basket portion.

**20.** The method of claim 19, wherein the step of connecting said rail to said basket portion further includes the step of welding.

**21.** The method of claim 16, wherein the step of connecting said mesh extensions to said first and second sidewalls further includes the step of welding.

**22.** The method of claim 14, wherein the step of connecting said first piece of mesh material to said second piece of mesh material further includes the step of using a fixture to support said first and second pieces of mesh material, said fixture including an electrode for supporting said first and second pieces of mesh material.

\* \* \* \* \*