

(19) World Intellectual Property Organization
International Bureau



(43) International Publication Date
11 January 2001 (11.01.2001)

PCT

(10) International Publication Number
WO 01/01845 A2

- (51) International Patent Classification⁷: **A61B**
- (21) International Application Number: PCT/IL00/00381
- (22) International Filing Date: 2 July 2000 (02.07.2000)
- (25) Filing Language: English
- (26) Publication Language: English
- (30) Priority Data:
60/142,052 2 July 1999 (02.07.1999) US
60/167,231 24 November 1999 (24.11.1999) US
09/607,842 30 June 2000 (30.06.2000) US
- (71) Applicant (for all designated States except US): **ULTRA-GUIDE LTD.** [IL/IL]; Etgar Street 1, Carmel House, Industrial Park, 39032 Tirat Hacarmel (IL).
- (72) Inventors; and
- (75) Inventors/Applicants (for US only): **PALTIELI, Yoav** [IL/IL]; Einstein Street 75, 34602 Haifa (IL). **SEGALESCU, Victor** [IL/IL]; Keren Hayesod Street 15, 34970 Haifa (IL). **SELLA, Dov** [IL/IL]; Hagalil Street 18, 40550 Even Yehuda (IL).
- (74) Agent: **EITAN, PEARL, LATZER & COHEN-ZEDEK**; 2 Gav Yam Center, Shenkar Street 7, 46725 Herzlia (IL).
- (81) Designated States (national): AE, AG, AL, AM, AT, AU, AZ, BA, BB, BG, BR, BY, BZ, CA, CH, CN, CR, CU, CZ, DE, DK, DM, DZ, EE, ES, FI, GB, GD, GE, GH, GM, HR, HU, ID, IL, IN, IS, JP, KE, KG, KP, KR, KZ, LC, LK, LR, LS, LT, LU, LV, MA, MD, MG, MK, MN, MW, MX, MZ, NO, NZ, PL, PT, RO, RU, SD, SE, SG, SI, SK, SL, TJ, TM, TR, TT, TZ, UA, UG, US, UZ, VN, YU, ZA, ZW.
- (84) Designated States (regional): ARIPO patent (GH, GM, KE, LS, MW, MZ, SD, SL, SZ, TZ, UG, ZW), Eurasian patent (AM, AZ, BY, KG, KZ, MD, RU, TJ, TM), European patent (AT, BE, CH, CY, DE, DK, ES, FI, FR, GB, GR, IE, IT, LU, MC, NL, PT, SE), OAPI patent (BF, BJ, CF, CG, CI, CM, GA, GN, GW, ML, MR, NE, SN, TD, TG).

Published:

— Without international search report and to be republished upon receipt of that report.

For two-letter codes and other abbreviations, refer to the "Guidance Notes on Codes and Abbreviations" appearing at the beginning of each regular issue of the PCT Gazette.

(54) Title: APPARATUS AND METHODS FOR MEDICAL INTERVENTIONS

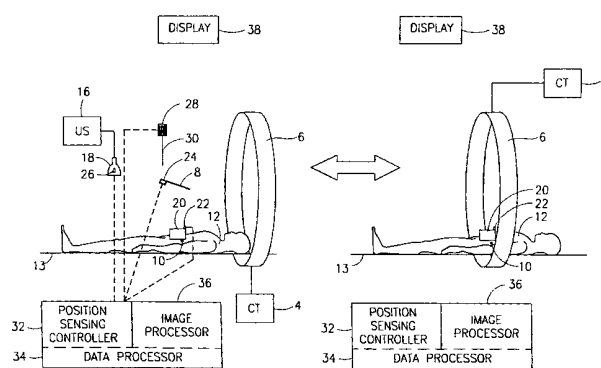

(57) Abstract: Systems and methods for medical diagnostic and for medical guided interventions using medical imaging systems are introduced. These systems and methods recognize the need for a relatively simple and modular way of using images produced by standard medical imaging devices to perform image guided medical interventions. Additionally these systems and methods enable to combine information available from two or more medical imaging apparatus in medical diagnosis and in image guided surgery and therapy. Particularly these methods enable to minimize mechanical constraints involved in a cooperative operation of several medical scanning devices. The apparatus and methods are based on using localizing devices comprising attachable position measuring components thus enabling to perform image guided medical interventions by calculating the position of a medical tool with respect to the image produced by the medical imaging device and/or with respect to the patient. These localizing devices enable to perform frameless stereotactic procedures anywhere in the body assisted by images produced by CT, MRI, X-Ray or other medical imaging devices. The methods and apparatus enable to position a second medical imaging device over a desired area/volume according to information received from the image produced by the first medical imaging device. Additionally the apparatus and methods facilitate image fusing when images of the same plane/volume are available from different medical imaging systems.



WO 01/01845 A2

APPARATUS AND METHODS FOR MEDICAL INTERVENTIONS

CROSS REFERENCE TO RELATED APPLICATIONS

5 This application is related to and claims priority from commonly owned and related U.S. Patent Application, S/N _____, entitled: APPARATUS AND METHODS FOR MEDICAL INTERVENTIONS, filed on June 30, 2000, and U.S. Provisional Patent Applications, S/N 60/167,231, filed November 24, 1999, and S/N 60/142,052, filed July 2, 1999, all three of these Patent Applications incorporated by
10 reference in their entirety herein.

FIELD OF THE INVENTION

The present invention relates to apparatus for performing medical interventions, medical diagnosis or medical therapy planning, based on image information available
15 from one or more medical imaging systems (such as an ultrasound, CT, MRI, X-Ray) with respect to the position of a target in a body volume. Particularly, it is related to apparatus for performing medical interventions anywhere in the body, when employing medical imaging systems for viewing the target during or prior to the intervention.

BACKGROUND OF THE INVENTION

20 During recent years, there has been significant improvement in medical image guided interventions. Several exemplary patents which detail some of those improvements are listed below.

U.S. Patent Nos. 5,483,961 and 5,787,886 disclose a system for guiding a
25 medical tool towards a target inside the head of a patient assisted by information produced by a CT or a MRI.

U.S. Patent No. 5,891,034 (Bucholtz) introduced a system for guiding a medical tool within a head on the image of the head produced by CT, MRI or X-ray.

The above discussed systems as well as the majority of existing stereotactic
30 systems and methods are based on the capability to attach a rigid frame or markers to the skull. In the rest of the body, however, there are no structures to which a rigid frame may be attached. Additionally, many of the organs within the cavity move with respiration so

that their position constantly changes according to changes in the phase of respiration.

There have been only a limited number of disclosed systems which propose ways to overcome these problems. For example, U.S. Patent Nos. 4,583,538 and 5,682,890 introduce systems and methods for guiding an invasive tool in other parts of the body
5 except the head.

Alternate systems and methods for guiding a medical tool towards a target in any part of a body volume assisted by medical imaging devices have been disclosed in commonly assigned U.S. Patent No. 5,647,373, and patent applications PCT/IL95/00050 and PCT/IL98/00578, all of these documents being incorporated by reference in their
10 entirety herein. These guiding systems and methods enable to guide a medical tool towards a target in a body volume without attaching any type of identifying assisting device (marker, position sensor, attached frame, etc) to the body of the patient.

SUMMARY OF THE INVENTION

The first embodiment of the present invention discloses a localization device
15 attachable on any portion of the body or in its vicinity. This localizing device defines a first reference coordinate system. The shape of the localizing device enables to calculate the position of any image produced by an imaging device with respect to the first reference coordinate system. A first position measuring component (single or multiple)
20 is attached at a known and fixed position onto the localization device. The first position measuring component may be part of a magnetic or acoustic or optical position measuring system. A second position measuring component (single or multiple) is attached to the medical tool to be guided. This enables to measure the position of the medical tool with respect to the reference coordinate system defined by the localizing
25 device.

An additional medical imaging device, such as an ultrasound transducer, comprises a third position measuring component (single or multiple) which enables to calculate the position of the ultrasound plane with respect to said first reference coordinate system.

30 More particularly, in the first embodiment, a localization device with guiding targets viewable on a medical imaging device such as a CT, MRI or same is placed at a fixed position on the body of the patient in the area to be scanned. The localizing device

has an adhesive base and it may be attached to any portion of the body. The localizing device defines a first reference coordinate system in space. Each CT (or MRI or X-Ray) image comprises a specific cross section of the localizing device and of the guiding targets. The shape and position of the guiding targets in the localizing device enable to calculate the position of each scan plane with respect to the first reference coordinate system by analyzing the cluster of targets in the CT or MRI image. This calculation may be performed based on any single image regardless of the relative angle of the CT (MRI) scan with respect to the localizing device. The position of a target appearing in the CT (or MRI) image may also be calculated with respect to the first reference coordinate system.

The localizing device includes a first position measuring component (single or multiple) at a known and fixed position from the first reference coordinate system (preferably the coordinate system associated with the first position measuring component coincides with the first reference coordinate system). By attaching a second position measuring component (single or multiple) to the medical tool it is therefore possible to calculate its position with respect to the CT (or MRI) images, and with respect to targets viewable in these images.

The first and second position measuring components (PMCs) are part of a position measuring system. This position measuring system may be magnetic (for example, Ascension Technology Corporation or Polhemus Inc. tracking systems), optic (for example Northern Digital Inc. tracking systems), acoustic (for example Science Accessories Corporation tracking systems), inertial (for example, an InterSense, Inc. inertial system) or combinations thereof. These position measuring components (PMCs) may be transmitters, receivers, reflectors, optical indicia, inertial sensors, or any combination of the above.

Additional embodiments of the present invention are particularly related to CT applications. The methods and apparatus in these additional embodiments are based on using the CT light beam defining the CT scanning plane.

In one embodiment, the localizing device comprises indicia in the form of scales and/or angles is attached to the body of the patient or next to it. The light beam of the CT crosses the indicia on said device and the operator manually inputs the numbers to the data processor which in return calculates the position of the scanning plane with respect

to the attached position measuring component. The localizing device comprises a first measuring component (single or multiple) at a known position as described in the first embodiment.

5 In another embodiment using the CT light beam for guidance, a reference position measuring component (single or multiple) is placed in space defining a reference coordinate system, preferably parallel, with the CT scanning plane or CT bed. A second position measuring component (single or multiple) is attached to the medical tool enabling to measure its orientation with respect to the reference position measuring component. It is therefore possible to calculate the position of the surgical tool with
10 respect to the CT scan plane. The entrance point is established by current techniques based on the CT image. It is therefore possible to maneuver medical tool in the correct orientation in order to contact the target.

BRIEF DESCRIPTION OF THE DRAWINGS

FIG. 1 pictorially illustrates one form of a system constructed in accordance with the first embodiment of the present invention for performing CT aided medical interventions.

FIG. 2a pictorially illustrates a localizer device to be used according to the first embodiment of the present invention as illustrated in FIG. 1;

FIG. 2b pictorially illustrates a localizer device to be used according to the first embodiment of the present invention as illustrated in FIG. 1;

FIG. 2c pictorially illustrates a localizer device to be used according to the first embodiment of the present invention as illustrated in FIG. 1;

FIG. 2d illustrates a localizing device to be used in accordance with the embodiment of the present invention illustrated in FIG. 1;

FIG. 3a illustrates the use of the localizer device illustrated in FIGS. 2a-2d in the system introduced in FIG. 1;

FIG. 3b illustrates the use of the localizer device illustrated in FIGS. 2a-2c in the system introduced in FIG. 1;

FIG. 4 illustrates the CT image of a patient with a localizer device on himself as illustrated in FIG. 2a ;

FIG. 5 pictorially illustrates the coordinates systems used in calculating the relative position between the scanning plane of a CT an ultrasound and an invasive tool according to the system illustrated in Fig. 1;

Fig. 6 is a block diagram describing the steps in using the system illustrated in FIG. 1;

FIG. 7a pictorially illustrates one possible position measuring system to be used in accordance to the present invention;

FIG. 7b pictorially illustrates one possible position measuring system to be used in accordance to the present invention;

FIG. 7c pictorially illustrates one possible position measuring system to be used in accordance to the present invention;

FIG. 8 pictorially illustrates the use of a system constructed in accordance with the first embodiment of the present invention for performing MRI aided medical

interventions;

FIG. 9 pictorially illustrates an alternative localizer device to be used according to the first embodiment of the present invention as illustrated in Fig. 1;

5 FIG. 10a pictorially illustrates another form of a system constructed in accordance with another embodiment of the present invention for performing CT aided medical interventions;

FIG. 10b illustrates a localizer device to be used in the preferred embodiment illustrated in FIG. 12a;

10 FIG. 10c illustrates a localizer device to be used in the preferred embodiment illustrated in FIG. 12a;

FIG. 11a pictorially illustrates one form of a system constructed in accordance to prior art for performing CT aided medical interventions;

FIG. 11b pictorially illustrates methods used during CT scanning images for localizing targets;

15 FIG. 11c pictorially illustrates the CT image obtained when taking a CT scan according to 11b;

FIG. 11d pictorially illustrates prior art methods when using localizer device from fig. 11a;

20 FIG. 12 pictorially illustrates another form of a system constructed in accordance with another embodiment of the present invention for performing CT aided medical interventions;

FIG. 13a pictorially illustrates another form of a system constructed in accordance with another embodiment of the present invention for performing CT aided medical interventions;

25 FIG. 13b illustrates a localizer device to be used in the preferred embodiment illustrated in FIG. 13a;

FIG. 14 illustrates a add-on method and system for monitoring the breathing phase of a patient in relation to the guiding systems illustrated in FIGs. 1-13 to be used in order to avoid guiding errors caused by the breathing of the patient;

30 FIG. 15a illustrates a method and apparatus for monitoring the breathing phase of the patient during the scan;

FIG. 15b illustrates the image produced while using the apparatus illustrated in

FIG. 15a;

FIG. 16 illustrates an alternative method and apparatus for monitoring the breathing phase of the patient during the scan; and

FIG. 17 illustrates a calibration/validation device to be used when employing a
5 CT and an ultrasound in a cooperative mode.

DETAILED DESCRIPTION OF THE DRAWINGS

Reference is now made to FIG. 1 that illustrates a first embodiment of the present invention. There is shown a CT apparatus 2 comprising CT main unit 4 and CT scanning
10 head 6, being used for guiding a medical (surgical) tool 8, such as biopsy needle, ablation device, etc., towards a target 10 in a body or body volume 12 (of a human or other mammalian body) being placed on a bed (or any other equivalent human or animal support) 13. An ultrasound apparatus 14 comprising a main unit 16 and an ultrasound transducer 18 may be optionally used in cooperative operation with CT apparatus 2 in
15 the medical intervention as further described. Fig. 1 illustrates the dynamic operation of the system which may change between positioning the patient (human or other mammalian animal) in CT scanning head 6 for CT scanning and then taking the patient out for performing invasive operations and/or ultrasound scanning and vice-versa. Taking the patient out of the CT scanning head for performing invasive procedures is
20 however not necessary, but rather an optional feature for freeing the field of work for the physician.

The system illustrated in FIG. 1 is operated as follows. Body or body volume 12 comprising target 10 is scanned by CT scanning head 6. A localizing device 20
25 comprising guiding targets viewable by CT, and further detailed below, is attached to body 12 above and/or below and/or around the area to be scanned. Localizing device 20 defines a first reference coordinate system. Each CT scan comprises a specific cross-section of the localizing device. The pre-designed shape and position of the guiding targets in localizing device 20 ensure a unique pattern of the guiding targets and localizer cross section for each CT scan position. It is therefore possible to use image
30 recognition algorithms in order to calculate the position of each CT image with respect to said first reference coordinate system. Localizing device 20 and its guiding targets may be made of various materials. The guiding targets may be made from plastic, carbon

fiber, aluminum, or other materials commonly used for manufacturing CT phantoms and provide a good contrast in a CT image. The guiding targets may be solid, hollow or tubular.

5 In order to correlate external devices to the first reference coordinate system a first position measuring component (PMC) 22 (single or multiple) is attached at a known and fixed position with respect to localizing device 20. PMC 22 (single or multiple) is therefore at known position with respect to the first reference coordinate system. Preferably, the coordinate system associated with first PMC 22 coincides with said first reference coordinate system.

10 The first position measuring component is part of a position measuring system. This position measuring system may be magnetic (for example, a tracking system available from Ascention Technology), optic (for example, a tracking system available from Northern Digital, Inc.), acoustic (for example, a tracking system available from Science Accessories Corporation), inertial (for example, a system available from
15 InterSense, Inc.), or combinations thereof. The term "position measuring component" could be a transmitter, receiver, reflector, optical indicia, inertial sensor, or combinations thereof.

Localizing device 20 may be attached to body 12 by several methods, preferably by using an adhesive or other self-adhering underside enabling fast attachment or
20 removal from body 12. The sticky underside may be moldable during the attachment process according to the shape of body 12, while the targets in localizing device 20 maintain their rigid shape and cluster. This enables attaching the localizing device 20 to any portion of body 12 or at least in the vicinity of any portion of the body. Localizing device 20 may be designed to be a disposable part being delivered as a sterile package or
25 it may be a part which may be sterilized before each procedure. Optionally, localizer 20 may be attached to bed 13 in a maneuverable way such that it may be placed over the patient during the procedure, while body 12 is held firmly and securely to the bed 13 by an immobilizing device.

Medical tool 8 comprises at a known and fixed position a second (single or
30 multiple) PMC 24. This may be achieved for example by using an appropriate adapter for attaching PMC 24 to the medical tool 8 as described in commonly owned PCT Patent Application PCT/IL99/00560, entitled: NEEDLE AND SENSOR ADAPTERS FOR

MEDICAL SYSTEMS (from Israel Patent application No. 126742), this PCT Patent Application incorporated by reference in its entirety herein. PMC 24 may be attached to any portion of medical tool 8 according to the nature and shape of the medical tool and of the PMC. Placing PMC 24 on the tip of the medical tool 8 offers advantages with regard to possible errors resulting from the bending of the medical tool 8 during its insertion. A third (single or multiple) PMC 26 is attached at a fixed and known position onto ultrasound transducer 18 optionally used in this embodiment. PMC 26 is calibrated to ultrasound transducer 18 by calibration methods disclosed in commonly owned patent application, PCT/IL98/00631, incorporated by reference in its entirety herein.

According to the nature of (single or multiple) PMC's 22, 24 and 26 (if an ultrasound transducer is used), a fourth (single or multiple) PMC 28 is optionally positioned at a second reference position in the work area. PMC 28 is preferably placed on an arm 30 not connected to the CT system. Optionally, the arm 30 may be attached to the bed 13. The role of this optional or additional PMC 28 is further explained below.

A position sensing controller 32 is connected by wired or wireless links with all or part of PMC's 22, 24, and optionally or additionally used PMC's 26 and 28. Position sensing controller 32 and at least one of PMC's 22, 24, and optionally or additionally used PMC's 26, 28, enable calculation of the position of medical tool 8 and the optionally used ultrasound transducer 18 with respect to the first reference coordinate system. Position sensing controller may be part of a data-processor 34 or may be connected to it. An image processor 36 is connected to CT main unit 4 receiving information regarding CT images (CT images through RGB, DICOM, or any other analog or digital form) enabling to display CT images and additional information as further explained on display 38. Image processor 36 may also be connected to optionally used ultrasound 14 and performing additional functions related to as further explained below. Image processor 36 may be part of the data processor 34 or may be connected to it. Optionally, data processor 34, image processor 36, position sensing controller 32 may be part of the CT main unit.

With respect to FIG. 2a a first preferred localizing device 20' is illustrated. The guiding targets comprised in this preferred localizing device are eight rods 41-43 and 46-49. The rods are arranged in two parallel planes: 41-43 and 46-49 each group having a shape similar to an asymmetric letter "M". The preferred sizes for such a device are $L = 3$

cm, $D = 5$ cm, $D1 = 2$ cm and $H = 3$ cm. A first reference coordinate system (FR_CS) is defined in relation to the localizing device as illustrated in FIG. 2a, and a first position measuring component coordinate system (FPMC_CS) is defined in relation to the first position measuring component as illustrated in FIG. 2a. The relative position between FR_CS and FPMC_CS is fixed and known..

With respect to FIG. 2b a second preferred localizing device 20'' is illustrated. The guiding targets comprised by this preferred device are four rods 50-53 arranged in a pyramidal shape. Preferably, OAC plane comprising rods 50, 51, 53 is placed on body 12 above target 10. Preferably, OA (rod 50) is perpendicular to OBC plane. A first reference coordinate system (FR_CS) is defined in relation to the localizing device, and a first position measuring component coordinate system (FPMC_CS) is defined in relation to the first position measuring component as illustrated in FIG. 2b. The relative position between FR_CS and FPMC_CS is fixed and known..

With respect to Fig. 2c a "V" shaped localizing device 20''' is illustrated. The "V" shape comprises two arms 55 and 56 and is hollow in the middle. On each arm rods 57 parallel to the base optionally enable to align localizing device 20''' with the CT scanning plane. Since localizing device 20''' is hollow in the middle its attachment to body 12 becomes less dependent of the curvature of the body portion under it. A first reference coordinate system (FR_CS) is defined in relation to the localizing device, and a first position measuring component coordinate system (FPMC_CS) is defined in relation to the first position measuring component as illustrated in FIG. 2c. The relative position between FR_CS and FPMC_CS is fixed and known..

With respect to FIG. 2d, a fourth preferred localizing device is illustrated. The guiding targets in this localizing device are eight rods 41'-49'. The rods are arranged on four faces of a box, each face typically having three rods, typically arranged in a "Z" shape. The preferred dimensions for such a box may be such that $L' = 3$ cm, $D' = 4$ cm and $H' = 3$ cm. A first reference coordinate system (FR_CS) is defined in relation to the localizing device, and a first position measuring component coordinate system (FPMC_CS) is defined in relation to the first position measuring component as illustrated in FIG. 2d. The relative position between FR_CS and FPMC_CS is fixed and known.

Although localizing devices 20' - 20'''' illustrated in FIGS. 2a - 2d are preferred, many alternative shapes may be chosen for building such a localizing device.

With respect to FIGs. 3a and 3b, a portion of body 12 including target 10 is scanned by the CT scanning head 6. Similar items as detailed in previous figures have similar numbers and are in accordance with the description above. CT scanning head 6 views a section 60 of body 12 and attached localizer 20. In Fig. 3a (single or multiple) PMC 22 is attached to localizer 20 during the CT scan. With respect to FIG. 3b, the (single or multiple) PMC 22 is attached to localizing device 20'''' through an extension 52 which ensures that PMC 22 is at a fixed and known position with respect to localizing device 20''''. This enables, for example, to insert PMC 22 in extension 62 after the CT scan. Extension 62 may be permanently attached to localizing device 20'''' or detachable. PMC 22 may be permanently attached to extension 62 or detachable.

Fig. 4 illustrates one possible scan image produced by CT apparatus 2 and viewable on display 38 according to scanning procedure illustrated in FIGs. 3a and 3b when using localizing device 20'''' illustrated in FIG. 2d. Cross sections of target 10' and of localizing device 20'''' appear in the image. The cross-section of the guiding targets has a unique cluster which enables to establish the position of the image with respect to the first reference coordinate system (FR_CS) and therefore with respect to (single or multiple) first PMC 22.

When using localizing device 20'''' illustrated in FIG. 2d cross sections of localizing device rods: 40'-43' and 46'-49' appear in the CT image. The position of cross sections of localizer rods may then be automatically recognized by image processor 36 or may be indicated off-line by the operator on image as shown on display 38, for example by clicking a mouse.

A short description of the concept follows. The relative geometry in the image between the cross-sections of the localizer rods 40'-43' and 46'-49' is unique for each possible cross-section of the localizing device, therefore enabling calculation of the relative position of the CT image plane with respect to the localizing device 20''''. Several algorithms may be used in order to calculate the position of the scanning plane with respect to the first reference coordinate system. Alternate calculations taking into account the size of the guiding targets, their intensity, the distance between the cluster cross-sections and the orientation of segments connecting pairs of cluster sections in the CT image may be used.

Data processor 34 establishes the position of the CT image with respect to the

first reference coordinate system. This calculation may be performed based on a single CT image. Using more than one CT scans with known relative positions may improve the accuracy of the above calculation. Optionally, the operator may then indicate the position of the target 12' in the CT image. Based on the above two calculations data processor 34 then computes the position of target image 10' with respect to the first reference coordinate system.

An additional feature resulting from attaching localizer device 20 to body 12 is that in each CT scan a point may be identified on patient's skin which is related to a corresponding point on the localizer device 20. For example, in FIG. 4 point 49' may be considered the reference point on the localizer device.

Fig. 5 pictorially illustrates the coordinates systems used in calculating the relative position between medical tool 8, target 10 and optionally used ultrasound transducer beam according to the preferred embodiment of the present invention as illustrated in Fig. 1. ICT_CS stands for the coordinate system associated with the CT image/scan. FR_CS stands for the coordinate system associated with the first reference coordinate system defined by localizer 20. A coordinate system is defined in relation to PMC 22. This coordinate system will be further defined as first PMC coordinate system, FPMC_CS. Since PMC 22 is attached at a known and fixed position with respect to localizing device 20, there is a known relationship between FPMC_CS and previously defined FR_CS. According to a preferred embodiment FPMC_CS and FR_CS coincide.

SPMC_CS (second PMC coordinate system) stands for the coordinate system associated with second PMC 22. MT_CS stands for the coordinate system associated with the medical tool 8. Since PMC 22 is at a known and fixed position with respect to medical tool 8 the relationship between MT_CS and SPMC_CS is known and fixed. TPMC_CS stands for the coordinate system associated with the (single or multiple) third PMC 26. IUS_CS stands for the coordinate system associated with the ultrasound image. For systems using the (single or multiple) fourth PMC 28 a related coordinate system is defined SR_CS (second reference position coordinate system).

FIG. 6 is a block diagram illustrating the steps involved in using the system illustrated in Fig. 1. Body 12 is scanned by CT scanning head 6 at step 100. This step is generally, but not necessarily, performed in two stages: first a set of CT scans is performed for the diagnosing and planning stage then at least one additional CT scan is

performed immediately prior or during the intervention itself. The images produced during the diagnosis stage are generally used for planning the intervention and according to this information an at least one CT scan (of desired resolution) is taken in a desired portion of body volume 12 comprising target 10. These later CT images assist the physician during the intervention. It is possible however, to perform the intervention assisted only on the images performed during the diagnosing stage, provided the localizing device 20 is already attached to the body of the patient.

Data processor 34 may store if requested by the operator all the available images or can work on images acquired on-line from the CT. CT images used for guiding the medical tool 8 are analyzed in order to identify cross-sections of the localizer 20, step 102. This is preferably performed automatically by image processor 36. However, the operator may assist the process by indicating localizing device cluster in the CT image. Optionally, target image 10' may also be identified in the CT image in a similar manner. In this case, image processor 36 calculates the position of the target image 10' with respect to the cross section of the localizing device 20" in the CT image.

As explained above, the pattern of localizing device 20 ensures a different and unique cross-section within different CT scanning planes or CT images. The cross-section of the localizing device 20, identified at step 102 in a CT image, is inputted to geometrical algorithms. Based on the uniqueness of the cross-section, it is therefore possible to calculate from a single image, the position of the CT image with respect to the first reference coordinate system FR_CS, step 104. It is also possible to find the relative position between two CT images comprising cross-sections of the localizing device 20. Generally, the relative position between two CT images scanned in the same scan is available from the CT scanner (DICOM, for example), or may be manually inserted by the operator or may be calculated from two images comprising cross-sections of the localizing device 20, as detailed above. Given that the relative position between the two CT images (scanned in the same session) is known, it is possible to calculate the position of the second image in the FR_CS from calculating the position of the first image in the FR_CS. It is therefore possible to calibrate CT images (slices) not comprising the localizing device 20 by calibrating a single CT image comprising a cross-section of the localizing device 20.

If several CT images comprising cross-sections of the localizing device are

available, step 102 may be based on analyzing more than a single CT image in order to improve accuracy and validate the calculation (calculating the position of CT image with respect to the first reference coordinate system).

5 Data processor 34 enables the operator to work with single CT images, typically acquired on-line, for example, from sampling the video output of the CT scanner. Data processor 34 also enables the operator to store CT images in an archive (DICOM or from video) and to work with images from the archive. Data processor 34 also enables the operator to switch between the two modes, detailed and described above.

10 Optionally, based on steps 102 and 104 the position of target 10 is calculated with respect to FR_CS, step 106. This calculation is actually a translation of coordinates between CT image coordinate system, ICT_CS and FR_CS.

When using CT-fluoroscopy, CT images of a certain slice (plane) are received at a high rate (4-10 HZ). In this case, data-processor 34 enables the operator to work with the continuous CT-fluoroscopy images.

15 Since the first (single or multiple) PMC 22 is at a fixed and known position with respect to the first reference coordinate system, knowing the position of a tensor in FPMC_CS automatically enables to calculate its position in FR_CS and vice-versa (preferably, FR_CS coincides with FPMC_CS). This means that the calculations at step 104 and 106 immediately enable the calculation of the position of the CT image and of target 10 respectively in FPMC_CS.

20 Position sensing controller 32 measures the position of the second (single or multiple) PMC 24 with respect to (single or multiple) PMC 22 at step 110. Based on the known relationship between MT_CS and SPMC_CS and the measurement at step 110, data processor 34 calculates the position and trajectory of the medical tool 8 in FPMC_CS step 112.

Based on steps 104 and 112, data processor 34 then calculates the position and trajectory of the medical tool 8 with respect to CT scanning plane or image at step 114. Optionally, based on steps 104 and 112 data processor 34 then calculates the position and trajectory of the medical tool 8 with respect to the target 10 at step 116.

30 Still optional, the physician may use the reference point in the image- see above- as the entry point. The reference point should be preferably chosen on the skin of the patient or on the localizing device 20.

The calculations performed at steps 114 and optional 116 are displayed on display 38 enabling to guide medical tool 8 towards target 10 step 116. The displayed information is preferably in the form of illustrating 3D information added by alphanumeric details. A preferred display is described in commonly assigned patent application PCT/IL96/00050, hereby incorporated by reference in its entirety herein. The display enables the physician to perform the procedure on-line as opposed to the current common off-line complicated and prolonged manual operations necessary to align medical tool 8 in the CT plane towards target 10. If several CT images with a known relationship are stored in data processor 34 it is possible to create an image volume to be displayed to the user, and show the position of the medical tool 8 with respect to this image volume. There exist several commercially available software packages which may be used for creating such image volumes from 2D CT images.

Alternate display schemes may be employed when image volume information is available, such as displaying the images of three perpendicular planes passing through the target or displaying the image of two perpendicular planes on which the medical tool lies. Still an alternative scheme for displaying volume information while performing a "cross slice" intervention is hereinafter described and is applicable to any imaging modality, for example, ultrasound, CT, MRI, etc. The image of the target slice comprising the target is displayed on the main window of the display screen 38, while a separate window on the display screen 38 shows the image of the slice (parallel with the target slice) in which the tip of the medical tool 8 is positioned. This enables to perform cross slice interventions while constantly monitoring the progress of the medical tool 8 and avoid damage to vital parts of the body 12 such as blood vessels.

When working in archive mode, i.e., with a set of CT images stored in the system, the operator can receive, upon selection, additional information in order to plan the intervention. Data processor 34 will show in this case on the system display 38, the trajectory of the medical tool 8 through the different images. The operator can therefore position the medical tool 8 on the body of the patient and see the expected cross points of its trajectory in the different slices. This information is presented by partitioning the display and displaying each slice in a different window, or by showing the images in a cine-mode in a dedicated window, or by showing the information in a 3D image volume in a dedicated window. The operator may activate and deactivate this display, upon

selection, at any stage of the intervention.

According to a preferred option, ultrasound apparatus 14 is also used in the guided intervention. The benefit of using in addition an ultrasound apparatus is that it enables to compensate for possible movements of target 10 with respect to position measuring component 22 due to patient breathing. A (single or multiple) third PMC 26
5 is attached at a fixed position with respect to ultrasound transducer 18. PMC 26 is calibrated to ultrasound scanning plane and image, for example by methods described in co-assigned PCT application PCT/IL98/00631, hereby incorporated by reference in its entirety herein. This calibration enables to know the position of ultrasound scanning
10 plane with respect to (single or multiple) PMC 26 and to establish a one-to-one relationship between TPMC_CS and IUS_CS.

Position sensing controller 32 measures the relative position of (single or multiple) PMC 26 with respect to (single or multiple) PMC 22 step 120.

Based on steps 120, 104 and the calibration information data processor 34
15 calculates the position of ultrasound scanning plane with respect to CT scanned plane/volume step 122. Optionally, based on steps 120, 106 and the calibration information data processor 34 calculates the position of ultrasound scanning plane with respect to target 10 step 124. It is then possible to maneuver ultrasound transducer 18 such as to view target 10 or view a specific CT image or CT image portion. It is also
20 possible, upon operator selection, that the data processor 34 render and display the stored CT images at each stage, the requisite CT image or portion thereof being the one to which the ultrasound transducer is aligned.

Optionally, the calculation at step 122 may be used for image fusing or image correlation between CT image and ultrasound image. Still optionally, the guidance of
25 medical tool 8 towards target 10 may then be performed based on ultrasound image only, see for example commonly assigned patent application PCT/IL96/00050, or according to CT image and assisted by ultrasound image step 128. Particularly, step 118 of displaying information regarding the position of the medical tool 8 with respect to scanned plane/volume or with respect to the target may be performed in parallel or
30 sequentially on CT and ultrasound images, or it may be displayed on a fused image.

The current invention is based on using a position measuring system enabling to measure relative positions of bodies in space. The term position defines in general

location and orientation. Magnetic (for example Ascension Technology Corporation or Polhemus Inc. tracking systems), optic (for example Northern Digital Inc. tracking systems), acoustic (for example Science Accessories Corporation tracking systems), inertial (for example, InterSense, Inc. inertial systems), or combinations thereof. Each (single or multiple) PMC (position measuring component) may be a transmitter, receiver, reflector, optical indicia, inertial sensor, or any combination of the above according to the nature of the position measuring system used and the additional implementation constraints (size of medical tool, line-of-sight requirements, etc).

FIG. 7a illustrates a magnetic position measuring system to be used in accordance to the present invention. Ascension Technology Corporation or Polhemus Inc. tracking systems are examples of such currently available systems. PMC 22' is a magnetic transmitter and PMC's 24' and 26' are magnetic receivers. In this embodiment, the position of medical tool 8 with respect to localizer 20 is measured directly. An alternate system may be built by choosing PMC 22' to be a receiver and PMC's 24' and 26' to be transmitters.

Fig. 7b illustrates an optic position measuring system to be used in accordance to the present invention. Northern Digital Inc. tracking systems are examples of such currently available systems. Each PMC's 22", 24", 26" is a set of LED's (at least two LED's in each set). PMC 28" is a stereo CCD camera (comprising at least two CCD's) for example. According to the image produced by the LED's on each of the CCD's the position of the medical tool 8 and the ultrasound transducer 18 are measured with respect to the coordinate systems defined by the array of CCD cameras 28" (SR_CS). It is therefore possible to calculate the position of the medical tool 8, and of the optionally used ultrasound transducer 18 with respect to the FPMC_CS (defined in relation to PMC 22). This is an example of a position measuring system which measures the position of the medical tool 8 with respect to localizing device 20 in an indirect manner (with the help of the additional reference single or multiple PMC 28).

Fig. 7c illustrates an acoustic position measuring system to be used in accordance to the present invention. Science Accessories Corporation tracking systems are examples of such currently available systems. Each of PMC's 22"', 24"', 26"' is a set of sound emitters (at least three sound emitters in PMC 22" and PMC 26" set and at least two sound emitters in PMC 24" set). PMC 28' is a set of microphones (at least three

microphones).

Additional variations of the position measuring system may be employed according to the present invention. Inertial position measuring system may also be used in such application as a “standalone” system or in combination with another type of position measuring system such as those available from InterSense Inc. Other combination of position measuring systems may also be used in order to combine benefits from different technologies. Additional examples of possible position measuring systems and components see for example commonly assigned patent applications PCT/IL96/00050 and PCT/IL98/00578, both hereby incorporated by reference in their entirety herein.

While the present invention was described in a preferred embodiment in connection to a CT guided interventions, it is similarly feasible in connection to MRI guided interventions as illustrated in Fig. 8. Similar items have similar numbers and will not further be described. Localizing device 20M and the cluster of guiding targets within the localizing device 20M must be manufactured from a material which is viewable by a MRI system. It is also possible to manufacture the guiding targets of localizing device 20M of materials viewable by both CT and MRI, enabling use of the same device for both applications.

The design of the localizing device 20M and the functionality of the system illustrated in FIG. 8 for MRI assisted interventions is identical to the design of localizing device 20 and the functionality of the system shown and described for FIG. 1, in relation to CT assisted interventions. Particularly, all of the features and functions illustrated in FIGs. 1-7b in relation to CT imaging are applicable to the system illustrated in FIG. 8 in relation to MRI imaging.

With respect to FIG. 9 an additional localizing device 146 is introduced. This device may be used for CT guided interventions instead of device 20 as described below. Device 146 comprises indicia on its perimeter, preferably, in the form of scales and numbers as illustrated 148', 148", 148''' and 148'''''. Alternative indicia may be used in similar ways. (Single or multiple) PMC 22 is attached at a fixed and known position onto localizing device 146 similar as to device 20. CT transversal beam light (available on CT systems) defines the current CT scanning plane. This beam of light is currently used by physicians for determining the position of the patient in the CT and also for

marking the CT scan plane on the body of the patient. Device 146 enables to employ this information in the following manner. The CT beam light intersects indicia 148'-148''' at four points. The operator manually inputs this numbers to data processor 34. Since the four points (three points are sufficient) define the position of the plane of the CT with respect to first reference position defined by localizer 146 data processor calculates this position. This replaces the automatically cluster pattern recognition performed in respect to localizer 20, equivalent to steps 102 - 104 illustrated in Fig. 6. The remainder of the procedure is similar to the method described above as shown in Figs. 1 and 6.

With respect to FIG. 10a, another preferred embodiment of a guiding system for CT guided invasive procedures is illustrated. Similar items as detailed in previous figures have similar numbers and are in accordance with the description above.. Localizing device 200 to be used instead of localizing device 20 is attached to body 12 by means similar to those described in relation to localizing device 20 (for example by means of an adhesive base moldable according to the shape of the body). Localizing device 200 or parts of it are maneuvered during the attachment process such that indicia 202 coincides with CT transversal light beam defining the CT scanning plane.

With respect to FIG. 10b and in relation to FIG. 10a, a preferred realization of localizer 200 is illustrated. The indicia 202 comprises two parallel lines connected by a perpendicular line. PMC 22 is attached onto localizing device 200 at a known and fixed position from indicia 202 (position measuring component 22 moves together with indicia as further explained). Localizing device also comprises a base 201 which may be attached to body 12 and a mechanism for translating and rotating indicia 202 in order to align it with CT light beam. Preferably, the rotating mechanism is in the form of a rotating ball 203 inserted in base 201 which enables changing the elevation angle and axes 204 which enables changing the azimuth angle.

With respect to FIG. 10c, another preferred realization of localizer 200 is illustrated. Indicia 202 contains two parallel lines connected by a perpendicular line as before and additional markers enabling to reduce errors resulting from the width of the CT light beam.

The operating process of a guiding system according to the embodiments illustrated in FIGS. 10a - 10c is described as follows. Body 12 is positioned such that target 10 is comprised in CT scanning plane. Localizer device 200 is attached to body 12

such that indicia 202 is comprised in CT transversal beam, i.e. the plane defined by indicia 202 is equivalent with the CT scanning plane. Body 12 is scanned by CT scanning head 6. The position of the CT scanning plane is known with respect to PMC 22, except for an ambiguous definition of the origin and x-y axis of the CT image. Preferably, the CT image is then analyzed and at least two points in the CT image belonging to known portions of the localizing device 200 are identified. The ambiguity regarding the origin and x-y axis is now resolved. This replaces the automatically cluster pattern recognition performed in respect to localizer 20, equivalent to steps 102 - 104 illustrated in Fig. 6. The rest of the procedure is similar to the method described above as shown in Fig. 6. in relation to Fig. 1.

With respect to Fig. 11a, a prior art device 250 for guiding a medical tool towards a target viewable in a CT scan is illustrated. Device 250 was introduced in U.S. Patent No. 4,733,661 (Palestrant). Several methods of guiding a medical tool 8 towards target 10 in body 12 have been developed to use the transversal CT beam light (available on CT systems) defining the CT scanning plane. The most common method is further described in relation to above cited U.S. Patent No. 4,733,661 Palestrant). The device includes a reference line 252 formed upon the base used to align the device with the transverse light beam projected by the CT scanner. The base also comprises a bubble level to assist in maintaining the base horizontal. A needle support connected to the base may be rotated to a desired angle. The value of the angle is indicated by angular indicia 258. Needle support 256 comprises a needle guide 160 for sliding a catheter towards the target. Length indicia 262 enables to establish the depth of insertion. The system is based on the assumption that the CT scan plane and associated transversal light beam are perpendicular to the floor.

With respect to Figs. 11b and 11c, CT guiding targets for example in the shape of carbon fiber rods 270 are attached to body 12. The cross-section of rods 270' is viewable in the CT image together with target cross-section 10'. The physician analyses the CT image and decides upon the desired point of insertion 272' and the desired trajectory. By marking in the image the desired entrance point 272' a point in the middle of the target 273', and point 274' (chosen such that the segment connecting points 273' and 274' is perpendicular) the operator receives information regarding the desired angle of insertion in the specific CT scanning plane. The point of insertion 272 may then be marked on the

body of the patient since it is defined in the image with respect to rods cross section 270'. Additional indicia indicating the cross section of the CT scan may also be marked on body 12 according to CT light beam. Device 250 is then placed over body 12 such that reference line 252 is in to transversal light beam or parallel to the indicia on body 12, and also horizontal. Device 250 it is then maneuvered such that tip of medical tool 8 touches entrance point 272 and the angle of entrance equals the desired entrance angle. Medical tool 8 is then inserted to the length calculated from the CT image.

Returning to the present invention and with respect to Fig. 12 an improvement to the prior art (described in Figs. 11a – 11d) is illustrated. Similar items have similar numbers and will not further be described. The determination of the entrance point 272 and the angle of entrance may be performed as described above in relation to Figs. 11b and 11c, the prior art, or by any other method.

Since CT's may change the elevation angle at of their scanning plane we define a reference CT scanning plane, preferably at zero elevation. i.e., perpendicular to the floor/regular position of the bed. (Single or multiple) PMC 280 is placed on an arm 282 at known orientation with respect to the CT reference scanning plane defining a second reference coordinate system in space, SP_CS. This may be achieved, for example, by using a calibration process as described in commonly assigned patent application PCT/IL98/00631, hereby incorporated by reference in its entirety herein, or by a similar process. Alternately, the calibration may be obtained by mechanical means such as using a standard bubble level attached to PMC 28. Preferably, SR_CS is parallel to CT reference scanning plane. Preferably, PMC 280 is attached to the CT scanning head 6 or placed on arm 282 in the proximity of the CT work area. Alternately, PMC 280 is attached and/or calibrated to CT bed 13.

(Single or multiple) PMC 24 is attached at a known and fixed position with respect to the medical tool 8 as in the previous embodiments. Medical tool 8 is then maneuvered such that its tip touches entrance point 272. Data processor 34 calculates the orientation of the medical tool 8 with respect to the desired orientation by measuring the position of PMC 24 with respect to PMC 280. This information is available to operator on display 38. If the operator decides to work according to a CT slice (plane) or image different from the reference CT scanning plane, information regarding the angle of this slice or image with respect to the reference scanning plane is inputted to data processor

32. If the CT bed 13 is swiveled during the CT scan or between performing the CT scan and the insertion process this information is also inputted to data processor 32.

Position sensing controller 32 measures the position of PMC 24 with respect to PMC 280. Based on this measurement, the above information and the knowledge of the insertion point (established according to current used procedures detailed in connection to prior art) data processor 34 calculates the orientation and trajectory of medical tool 8 with respect to the requested trajectory. This information is displayed to the operator on display 38 enabling him to align the needle in desired direction. Medical tool 8 is then inserted in the desired trajectory. In order to know the depth of the insertion the operator signals data processor that it is in inserting position when medical tool tip is touching the insertion point. Data processor may then calculate the depth of insertion based on the measurements made according to PMC 24. This information is also displayed to the operator on the CT image.

All the various types of position measuring systems detailed in connection to the previous embodiments are applicable for this embodiment also. It is possible to use such systems which provide only orientation measurements in order to align the medical tool 8 with the desired entrance plane.

Fig. 13a illustrates another preferred embodiment of a guiding system for performing CT guided invasive procedures. This system is an improvement with respect to the system illustrated in Fig. 12a since it enables to establish automatically the CT scanning plane position and not only its orientation with respect to position measuring component 280. This is achieved by attaching a localizing device 290 to the body 12.

A preferred realization of localizer device 290 to be used in the embodiment illustrated in Fig. 13a is illustrated in Fig. 13b. Similar items have similar numbers and are not further described. Localizer device 290 comprises a base 201 attachable to body 12, indicia 292 in the forms of a plastic rod and markers allowing to align localizing device 290 with CT light beam. (Single or multiple) PMC 22 is attached onto localizing device 290 at a known and fixed position. The orientation of the CT scan is known with respect to PMC 280 similar as for the embodiment illustrated in Fig. 12.

The use of the guidance system illustrated in Figs. 13a and 13b is as follows. Body 12 is positioned for taking a CT scan comprising target 10. Localizing device 290 is positioned on body 12 such that indicia 292 is aligned with CT light beam. Body 12 is

scanned. Position of indicia 292 is detected in the CT image. Preferably, CT bed 13 may be moved in order to allow space for the intervention. The position of PMC 22 is measured with respect to PMC 280. Combining this measurement with the known orientation of the CT scanning plane with respect to PMC 280 and with the identified position of indicia 292 in the CT image enables to fully establish the position of the CT image with respect to PMC 280 (or with respect to PMC 22). This replaces the automatically cluster pattern recognition performed in respect to localizer 20, equivalent to steps 102 – 104 illustrated in Fig. 6. The rest of the procedure is similar to the method described in relation to Fig. 6. in relation to Fig. 1.

For example, define the CT reference plane as the perpendicular plane. The coordinate system of PMC 280 is aligned with this reference plane or at least calibrated to it. The starting point and the end point of indicia 292 are positioned in the CT scanning plane and are at a known and fixed position with respect to PMC 22. This is the equivalent of the registration of two points in the CT image with respect to PMC 22. The orientation of PMC 22 is then calculated with respect to PMC 280. Since PMC 280 is aligned or at least calibrated with the CT reference scanning plane, it is therefore possible to calculate the orientation of the CT reference scanning plane with respect to PMC 22. The orientation of the CT reference scanning plane with respect to PMC 22 together with the previously calculated position of two points in the CT scanning plane with respect to PMC 22 enables to calculate the position of the CT reference scanning plane with respect to PMC 22. It is optionally possible to convert this calculation to calculating the position of the CT reference scanning plane with respect to PMC 280. This completes the full registration between the CT image and the tracking system. If the patient is scanned at an angle different then the CT reference scanning plane it is only necessary to compensate ion the calculations for the rotation of the scanning plane and/or swivel of the bed.

While the invention illustrated in FIGs. 12-13b was described in connection with CT imaging, this was exemplary. The invention is readily applicable in a similar manner for Magnetic Resonance Imaging (MRI), with minor modifications made for MRI.

One issue which is related with guiding a medical tool based on CT or MRI images is the movement of the target as a result of patients breathing. Currently, physicians resolve this problem by requesting the patient to exhale/inhale before taking

the CT images and exhale/inhale before inserting the medical tool. This should ensure that the CT image and the insertion of the medical tool take place when the patient is in the same breathing situation, and therefore the same target position in the body. This method may be implemented in relation to the present invention.

5 A method for monitoring the respiration phase of the patient (or any movement of the body 12 in general) is illustrated in Fig. 14. (Single or multiple) PMC 300 is attached to body 12, preferably in the area of target 10. According to one embodiment, a reference (single or multiple) PMC 302 is positioned at a fixed reference position in space. Such a setup is readily available (with no additional components) in embodiments using PMC 22 and PMC's 28 or 280 (in this case PMC 22 may be used as PMC 300 and
10 PMC 28 or 280 may be used as PMC 302). Measuring the position or the changes in the position of PMC 300 attached to body 12 with respect to the fixed external reference coordinate system related to the PMC 302 enables to monitor patients breathing phase.

The first issue to be resolved is correlating between the measurements of the
15 breathing phase based on PMC 300 and PMC 302 and the CT scans. Data processor 34 and CT main unit have synchronized clocks. Data processor 34 continuously records the position or the changes of position of PMC 300 with respect to the fixed coordinate system defined by PMC 302. CT main unit 4 transfers by standard data link (RS-232, USB, etc., wired or wireless) to data processor 34 information regarding the time of
20 producing each CT scan. Data processor 34 then calculates the breathing phase of the patient at the time each CT scan was produced. Alternately, data processor 34 may receive the time at which a CT scan is produced from the information recorded on the correspondent CT image therefore avoiding the necessity of a data link between CT main unit 4 and data processor 34. Once the breathing phase is known in relation to each
25 CT scan, this information may be used in two different ways. As an alternative method for correlating the measurements of the breathing phase based on PMC 300 and PMC 302 and the CT scans the operator may signal data-processor 34 each time a new CT scan is taken. Alternately, CT main unit 4 may automatically signal data processor 34 each time a new scan is taken.

30 According to another embodiment illustrated in FIG. 14 the position of PMC 302' is positioned on the body of the patient, preferably in the area of target 10. In order to monitor the respiratory position of the patient the position of PMC 300 is measured

relative to PMC 302'. PMC 302' may be identical to PMC 22 attached to localizing device 20, 20M, etc or a different PMC. PMC 302 and 302' are used interchangeable or simultaneously for monitoring the respiratory position of the patient.

5 According to still another embodiment illustrated in FIG. 14 PMC 300 is an inertial sensor whose position may be measured without necessitating an additional reference PMC.

In another embodiment PMC 300 may be a electro-mechanical device responsive to the respiratory changes of the patient. Stretchers, pressure monitoring devices or other similar devices may be used. It is therefore possible to monitor the respiratory position
10 of the patient solely according to the outputs of PMC 300 without necessitating an additional PMC.

An alternative method for recognizing the breathing phase of the patient during the scan is hereinafter described and is illustrated in FIGs. 15a and 15b. At least two localizing devices 310 and 312 are positioned on the body 12 in the area of interest such
15 that their cross section is viewable in the CT image comprising target 10. These localizing devices may be similar to localizing device 20 or 20M, or 290. Each localizing device 310 and 312 comprises or enables to attach a PMC at a known and fixed position with respect to the localizing device.

The cross-sections of localizing devices 310 and 312 are viewable in the CT
20 image. As described above it is possible to calculate the position of PMC 314 and 316 with respect to the CT image according to the cross section of localizing devices 310 and 312 respectively. These two calculations enable to then calculate the relative position and orientation between PMC 314 and 316 at the time the CT image was taken.

The above method and calculation is still applicable for cases in which the
25 cross-section of the localizing devices 310 and the cross-section of localizing device 312 is visible in different CT images (i.e. there is no image comprising cross-sections of both localizing devices). In this case, as explained above, the position of the CT images may be calculated with respect to a localizing device provided there is at least one other image (in the same scan) comprising a cross-section of the localizing device. By
30 extrapolation method it is therefore possible to calculate the relative position between PMC 314 and PMC 316 although the localizing devices 310 and 312 are positioned in the same CT slice.

While performing the intervention the relative position and orientation of PMC 314 and 316 is calculated through the measurements of the position sensing controller 32. It is therefore possible to monitor and compare their relative position with their relative position when the CT image was produced. The breathing position of the patient is similar to that while taking the CT image when the relative position between the two PMC's equals (within a certain margin) their relative position as calculated from the CT image. It is now possible to attach PMC 318 to a medical tool 8 and perform the intervention as described above while monitoring the patient's breathing phase with respect to the breathing phase during the CT scan.

When the position tracker system demands using a reference PMC 320 (see previous description of tracker types and architectures) it is possible that after recognizing the breathing phase of the patient during the CT scan to lock the reference position of PMC 314 with respect to PMC 318. This enables to continue monitoring the breathing phase of the patient by means of PMC 314 and PMC 318. It is therefore possible to afterwards detach PMC 316 and attach it to medical tool 8 for performing the intervention. This enables to reduce the number of necessary PMC's for a procedure.

A variation to the above described version is hereinafter described. Only one localizing device is positioned on the body of the patient 12 as above described. At least one additional marker is placed on the body 12 as to be visible in the CT image. When performing the intervention and after calibrating the system as above described the tip of the medical tool 8 comprising a PMC 24 is positioned on the marker touching at least one point. The physician observes the deviation of the calculated position of the tip from the point on the marker as displayed on display 38 and indicates to the system when this deviation is minimal. This is considered to be the reference breathing phase.

An alternative method for monitoring the breathing phase of the patient during the scan is herein described and illustrated in FIG. 16. An arm 330 attached to the CT bed 13 has an extension 332 which may be placed on the patients body12 in the area to be scanned. The extension is free to move vertically on the shaft 334 according to the breathing position of the patient. The height of the extension 332 from the bed 13 may be calculated from the image establishing the breathing phase during the scan. Indicia on the shaft 334 indicates the physician what is the height level of the extension 332 with respect to the bed 13 while performing the intervention. Alternatively, a PMC 340

attached to the extension 332 may indicate this position during the intervention. Still alternately, electro-mechanical means attached to the arm 330 comprising for example encoders produce an electrical signal according to the height of extension 332 from bed 13. This electrical signal may then be translated to the height of the extension 332 from bed 13.

An enhancement of the breathing monitoring methods that provides the information regarding the difference between the breathing position of an internal organ during the CT scan and the breathing position of the same internal organ during the intervention is as follows:

A real time imaging modality, for example, ultrasound, is used to identify the internal organ. The internal organ is locked-on (by analyzing the image, identifying the organ and locking on it). An additional PMC is attached to the imaging equipment, i.e., the ultrasound transducer. It is now possible to monitor and compare the relative position of the internal organ against the breathing position in which the CT image was taken, and to correct the display of the interventional tool according to the breathing pattern.

All of the breathing monitoring methods that were described above in relation to CT imaging are also applicable in MRI and may be used as such for MRI assisted procedures.

All the breathing monitoring methods described above provide information regarding the difference between the breathing position during the scan and the breathing position during the intervention. This information may be used as hereinafter described.

One way for avoiding errors caused by the breathing of the patient during the procedure is to ensure that the scan and the insertion are both made in the same breathing phase. The operator chooses the scan according to which intervention will be performed (the image comprising the target 10). This image is displayed on display 38. Data processor 34 displays on display 38 information regarding the difference between the breathing phase during the intervention and the breathing phase during the scan (for example in the form of box 304). The operator may then instruct the patient to inhale or exhale until reaching the desired breathing phase within a desired level of accuracy.

A second method for avoiding errors caused by the breathing of the patient during the procedure compares the breathing phase during the scan and during insertion

of the medical tool 8 and compensates for displacement errors caused by differences in the breathing phase. One possible option is to define a compensation algorithm based on an empirical model describing the changes of the position of a target with respect to the first reference coordinate system. Preferably, however, the compensation algorithm is based on taking several images of the same slice (plane) comprising the desired target 10 at different breathing phases and storing these images in the memory of data processor 34. This enables to correlate between the position of target 10 with respect to the FR_CS (first reference coordinate system) at different breathing phases. If there is a difference between the breathing phase at which the image was produced and the breathing phase at which the intervention is performed data processor 34 extrapolates its guiding calculations accordingly and also indicates on display 38 that the calculations are based on such on extrapolation.

An additional solution for overcoming the issue of guidance errors potentially caused by the patient's breathing is to use an ultrasound in the guidance process as explained above in accordance to FIG. 6. This adds a real time image during the procedure, therefore reducing to a minimum the effect of patient breathing.

Still additional solutions are to use CT-fluoroscopy (when using a CT) or continuous MRI images of the same slice (plane) to provide continuous imaging which monitors changes caused by breathing during the intervention.

In relation to using an ultrasound transducer in cooperation with the CT a method and a device for validating the accuracy of the system and for additional calibration is introduced. Fig. 14 illustrates a preferred embodiment of such a calibration (validation) device 300. Device 300 comprises guiding targets viewable by CT and guiding targets viewable by ultrasound.

In the preferred embodiment illustrated in FIG. 17 device 410 comprises two major sub-components. The first sub-component is localizing device 20 with an attachment for (single or multiple) PMC 22. The second sub-component 412 is a box comprising ultrasound guiding targets at known positions and lying in a material which enables them to be viewed in an ultrasound image (glycol, mineral oil, distilled water, etc). For example, sub-component 312 may be an ultrasound calibration device of the type described in commonly assigned patent application PCT/IL98/00631, incorporated by reference in its entirety herein. Localizing device 20 is attached at a fixed and known

position on device 412. This enables to know the position of the ultrasound guiding target with respect to the first reference coordinate system defined by localizing device 20.

5 The usage of calibration (validation) device 410 is as follows. Localizing device 20 is attached at a known and fixed position on top of box 302. A CT scan of device 410 over localizing device 20 is taken. The geometric algorithms establish the position of the CT scanning plane with respect to first reference coordinate system as before. (Single or multiple) PMC 26 is attached to ultrasound transducer 18 at a known and fixed position with respect to the ultrasound scanning plane.

10 According to one method ultrasound transducer 18 is positioned over calibration (validation) device 410 such that its scanning plane coincides with a predefined calibration reference plane defined by the ultrasound guiding targets in box 312 (as detailed in PCT/IL98/00631). Recognizing the calibration reference plane is performed by image processing methods for example as described in above cited PCT/IL98/00631.
15 The position of the calibration reference plane is known with respect to FR_CS (the first reference coordinate system). The angle between the ultrasound transducer scanning plane and the CT scanning plane is calculated in parallel based on the guiding calculations (step 120 and step 122). This calculated position of scanning plane is compared with the known position (according to the mechanical known attachment) of
20 the reference plane with respect to the FR_CS. This enables to test the accuracy of the calculations and also to calibrate the system.

While invasive procedures have been detailed above, alternate embodiments of the present invention may be directed to various directional therapy procedures (based on directing an energy field towards a target in a body). These procedures are typically
25 involve non-invasive medical (surgical) tools. The term directional therapy procedure will define any procedure during which an energy field is directed towards a target or area in the body of the patient. This energy field may be ultrasonic or shockwaves (lithotripsy), or electromagnetic (radiotherapy, laser, etc) or particle beam (proton beam for example). The data processor receives the information from the position measuring
30 system and uses it for directing the therapy device head\beam towards a desired target in the body. The attached PMC is at a known and fixed position with respect to the energy field produced by the non-invasive medical tool.

The present invention described several types of localizing devices to be attached onto the body of the patient. While the functionality of the above devices was fully described in relation to FIGs. 1 – 17 the attachment technique to be used was only partially addressed. The following section addresses this exact issue.

5 According to one embodiment the localizing device is attached to the body of the patient by means of an adhesive base such as a dual-tape glue. According to another embodiment the localizing device is attached to the body by means of an intermediary basis designed to remain attached onto the body even after removing the localizing device. . Preferably still the PMC is attached to the intermediary basis. According to a
10 preferred embodiment the intermediary basis is a belt with multiple housing for attaching the localizing device.

 There are cases when it is desirable to scan the patient and then perform the intervention outside the CT or MRI room. The systems described in the embodiments illustrated in Figs 1 – 16 enable this option according to the following method. The
15 patient is scanned with localizing device attached onto. He is then transferred to another site where the intervention is to be performed. The scanned images are transferred to the system for storing. As long as the localizing devices remain attached to the patient or they may be repositioned in the exact location the guidance information is available. Using an intermediary basis becomes particularly useful in such an implementation.
20 Optionally, markers being attached to the body of the patient can also indicate how to relocate the localizing device onto the body in the exact position it was placed during the scan.

 While preferred embodiments of the present invention have been described so as to enable one skilled in the art to practice the invention, the preceding description is
25 intended to be exemplary only. It should not be used to limit the scope of the invention, that should be determined by reference to the following claims.

CLAIMS

1. A method for directing a medical tool towards a target in a body volume, the method comprising the steps of:

5 attaching a localizer device to said body in the area to be scanned by a first medical imaging device, said localizer device defining a first reference coordinate system and comprising an at least one first position measuring component at a known and fixed position with respect to said first reference coordinate system;

producing at least one image of said body comprising said target by said first medical scanning device said image comprising at least a cross section of said localizer device;

10 calculating from the pattern of the cross section of said localizer device in said at least one image the position of said scanning plane/volume with respect to said first reference coordinate system;

attaching an at least one second position measuring component to said medical tool at a known and fixed position;

15 measuring the position of said at least one second position measuring component with respect to said at least one first position measuring component;

calculating the position of said medical tool with respect to the scanning plane/volume based on the above measurement and based on the calculation of the position of the scanning plane/volume with respect to the first reference coordinate system;

20 and displaying the position and/or trajectory of said medical tool with respect to said target on the image produced by said medical imaging device.

2. Method according to claim 1 where the step of producing said image is performed by CT.

25

3. Method according to claim 1 where the step of producing said image is performed by MRI.

4. Method according to claim 1 where the step of attaching the localizer device may be performed on a part of the body in the proximity of the area of interest for any desired part of the body.

30

5. Method according to claim 1 where the step of attaching the localizer device to said body is performed with no constraints.
6. Method according to claim 2 where the step of attaching the localizer device to said body is performed such that a desired portion and/or indicia on the localizer device is aligned with the CT transversal light beam.
7. Method according to claim 1 where an at least one position measuring component is placed at a fixed position in space creating a second reference coordinate system.
8. Method according to claim 7 where said second reference coordinate system has a known orientation with respect to the scanning plane/volume of said first imaging device.
9. Method according to claim 7 where said second reference coordinate system has an unknown orientation with respect to the scanning plane/volume of said first imaging device.
10. Method according to claim 1 where the movement of the bed on which said body is placed is measured and this measurement is used in the guidance process.
11. Method according to claim 1 where the at least one image is one.
12. Method according to claim 1 where the at least one cross section of said localizer device is one.
13. Method according to claim 1 where it is calculated the position and/or trajectory of said medical tool with respect to said target.
14. Method according to claim 1 whereby the breathing situation of the patient is monitored in order to diminish possible resulting errors in guiding said medical tool towards said target.

15. Method according to claim 14 whereby the monitoring of the breathing situation is based on measurements made according to said at least one first position measuring component.
- 5
16. Method according to claim 14 whereby the monitoring of the breathing situation is based on measurements made according to an additional position measuring component attached to said body.
- 10
17. Method according to claim 1 where an ultrasound system is additionally used for assisting in guiding said medical tool.
18. Method according to claim 17 whereby an at least one third position measuring component is attached to said ultrasound transducer at a known and fixed position, enabling to measure its position with respect to said at least one first position measuring component.
- 15
19. Method according to claim 17 whereby the images produced by the ultrasound and said first imaging device are correlated and/or fused and/or displayed in some other cooperative form.
- 20
20. A system for directing a medical tool towards a target in a body volume, said system comprising:
- 25
- a position measuring system comprising a position measuring controller and position measuring components;
 - a first imaging device for scanning said body comprising said target
 - a localizer device to be attached to said body on an area to be scanned by said first imaging device, said localizer device having the following properties:
 - defining a first reference coordinate system,
 - 30 being viewable by said first imaging device such that its cross sections pattern as imaged by the first imaging device and/or attached indicia enable to establish the position of the scanning plane with respect to said first reference coordinate system,

and comprising at least one first position measuring component at a known and fixed position from said first reference coordinate system;

an at least one second position measuring component attached at a known and fixed position on said medical tool, whereby the position measuring controller measures the relative position between said at least one first and said at least one second position measuring components;

a data processor calculating the position of said medical tool with respect to said scanned plane/volume based on the measurements of said position measuring system and based on the information regarding the cross section patterns of the localizer device as produced by the imaging device, and displaying the position and/or trajectory of said medical tool with respect to said target on the image produced by said medical imaging device.

21. System according to claim 20 where said first imaging device is a CT.

15

22. System according to claim 20 where said first imaging device is a MRI.

23. System according to claim 20 where said localizer device may be attached to any part of said body or at least in the proximity of any part of said body.

20

24. System according to claim 20 where each cross section of said localizer device as shown in images produced by said first imaging device is unique and enables to establish the position of the scanning plane/volume with respect to said first reference coordinate system.

25

25. System according to claim 21 where localizer device comprises indicia enabling to be aligned with the CT transversal light beam.

26. System according to claim 21 where localizer device comprises indicia enabling to establish the position of the scanning plane/volume with respect to said first reference coordinate system based on the CT transversal beam light.

30

27. System according to claim 20 where calculating the position of the scanning plane/volume with respect to said first reference coordinate system is based on a single image produced by said first imaging device.
- 5 28. System according to claim 20 where calculating the position of the scanning plane/volume with respect to said first reference coordinate system is based on taking several images by said first imaging device.
- 10 29. System according to claim 20 where it is calculated the position and/or trajectory of said medical tool with respect to said target.
- 15 30. System according to claim 20 whereby the breathing situation of the patient is monitored in order to diminish possible resulting errors in guiding said medical tool towards said target.
- 20 31. System according to claim 30 whereby the monitoring of the breathing situation is based on measurements made according to said at least one first position measuring component.
- 25 32. System according to claim 30 whereby the monitoring of the breathing situation is based on measurements made according to an additional position measuring component attached to said body.
- 30 33. System according to claim 18 where an ultrasound system is additionally used for assisting in guiding said medical tool.
34. System according to claim 28 whereby an at least one third position measuring component is attached to said ultrasound transducer at a known and fixed position, enabling to measure its position with respect to said at least one first position measuring component.
35. System according to claim 28 whereby the images produced by the ultrasound and

said first imaging device are correlated and/or fused and/or displayed in some other cooperative form

5 36. System according to claim 20 where an at least one position measuring component is placed at a fixed position in space creating a second reference coordinate system.

37. System according to claim 36 where said second reference coordinate system has a known orientation with respect to the scanning plane/volume of said first imaging device.

10

38. System according to claim 36 where said second reference coordinate system has an unknown orientation with respect to the scanning plane/volume of said first imaging device.

15 39. System according to claim 20 where the movement of the bed on which said body is placed is measured and this measurement is used in the guidance process.

40. System according to claim 20 where the position measuring system is magnetic.

20 41. System according to claim 20 where the position measuring system is optic.

42. System according to claim 20 where the position measuring system is acoustic.

43. System according to claim 20 where the position measuring system is inertial.

25

44. System according to claim 20 where the position measuring system is a combination of at least two types of guiding system from the following group: magnetic, optical, acoustic, inertial, mechanical.

30 45. System according to claim 20 where said medical tool is from the group: biopsy needle, needle, ablation device, cryo device, endoscopy device.

46. System according to claim 20 where said medical tool is any other possible tool.

47. A method for monitoring the breathing phase of the patient during the scan comprising the steps of:

- 5 attaching two localizing devices on the body of the patient such that their cross-section is viewable in the image;
said localizing devices comprising each at least one first position measuring component and respectively at least one second position measuring component attached onto at a known position;
- 10 calculating from the image the relative position between the localizing devices and/or the relative position between said attached at least one first and at least one second position measuring component;
defining this calculated relative position as the reference relative position correlated to the breathing position of the patient during the scan;
- 15 measuring the relative position between the first and second at least one position measuring components;
comparing this measurement with the calculated reference relative position and monitoring in this way the breathing phase of the patient with respect to his breathing phase during the scan; and displaying this information to the user in the
- 20 form of visual and audio information.

48. A method for real time monitoring of the breathing phase of an internal organ comprising:

- 25 attaching two first localizing devices on the body of the patient such that their cross-section is viewable in the image;
attaching a second localizing device to a real time imaging modality;
said localizing devices comprising each at least one first position measuring component and respectively at least one second position measuring component attached onto at a known position;
- 30 calculating from the image the relative position between the localizing devices and/or the relative position between said attached at least one first and at least one second position measuring component;

- defining this calculated relative position as the reference relative position correlated to the breathing position of the patient during the scan;
- measuring the relative position between the first and second at least one position measuring components;
- 5 comparing this measurement with the calculated reference relative position and monitoring in this way the breathing phase of the patient with respect to his breathing phase during the scan;
- displaying this information to the user in the form of visual and audio information;
- identifying an internal organ and locking onto said organ;
- 10 setting a reference relative position with respect to said organ; and
- correcting the display of the interventional tool in accordance with said breathing pattern.
49. The method of claim 48 wherein said real time imaging modality includes an
- 15 ultrasound transducer.

2/20

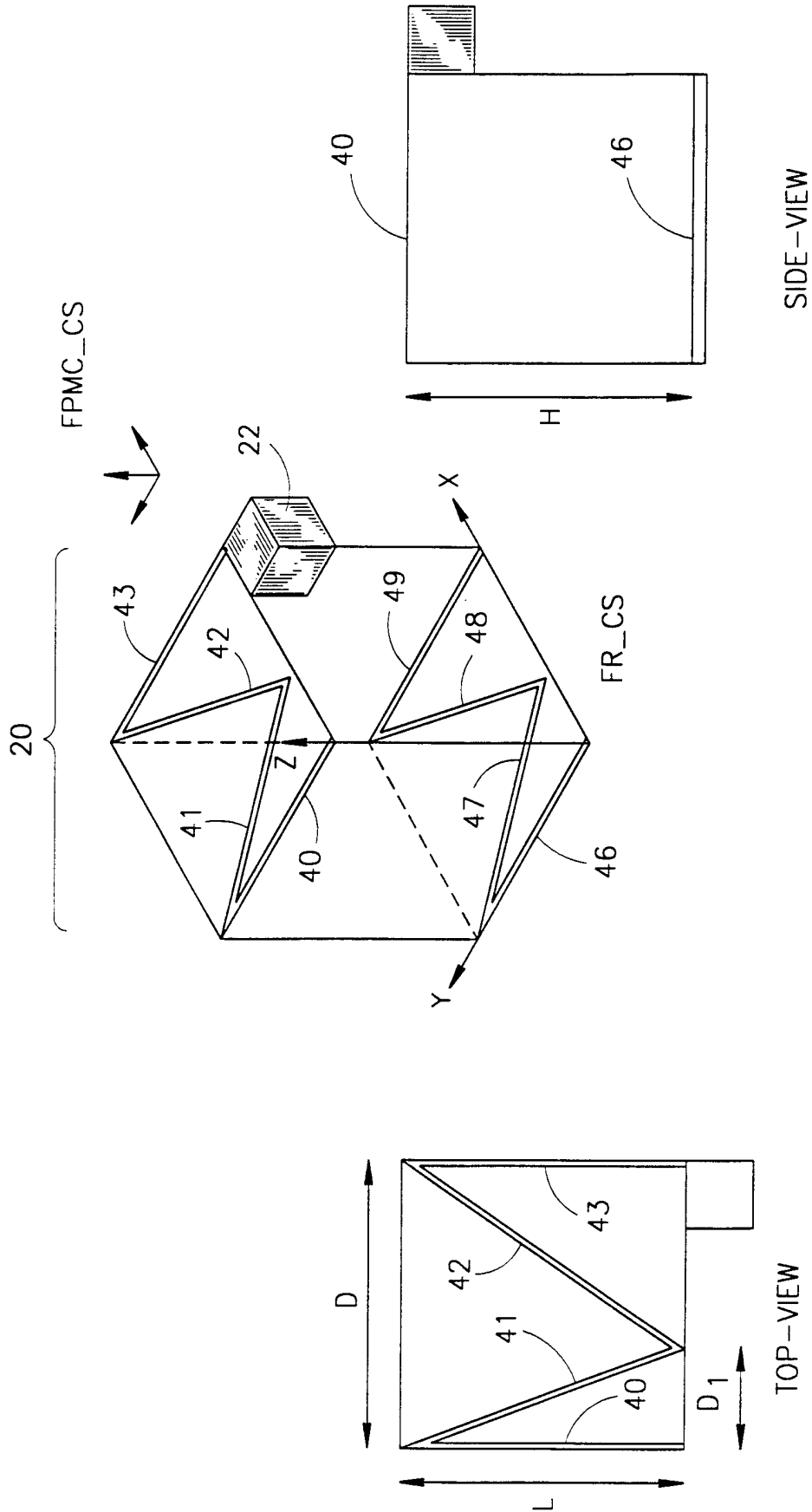

FIG.2A

4/20

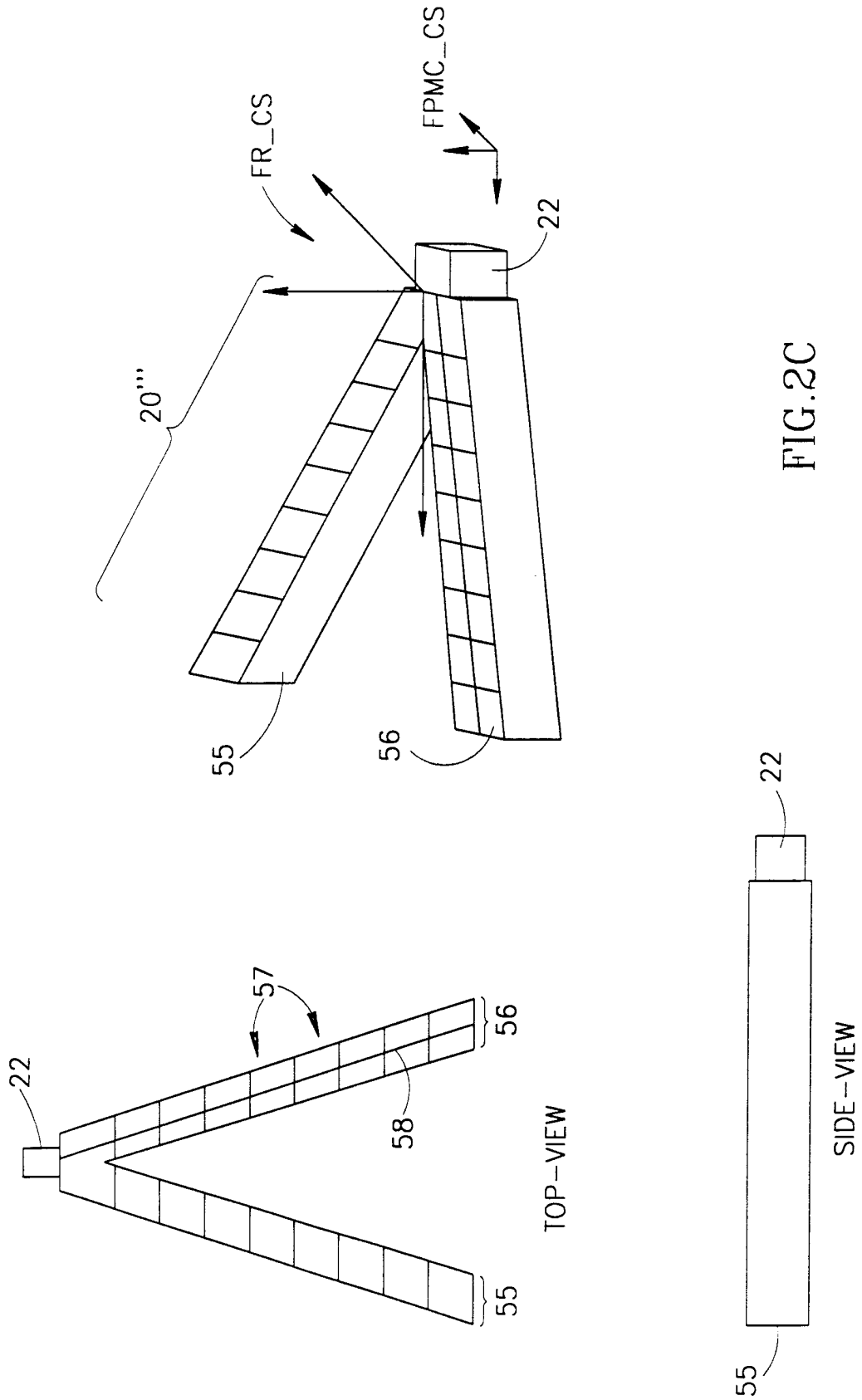

FIG.2C

5/20

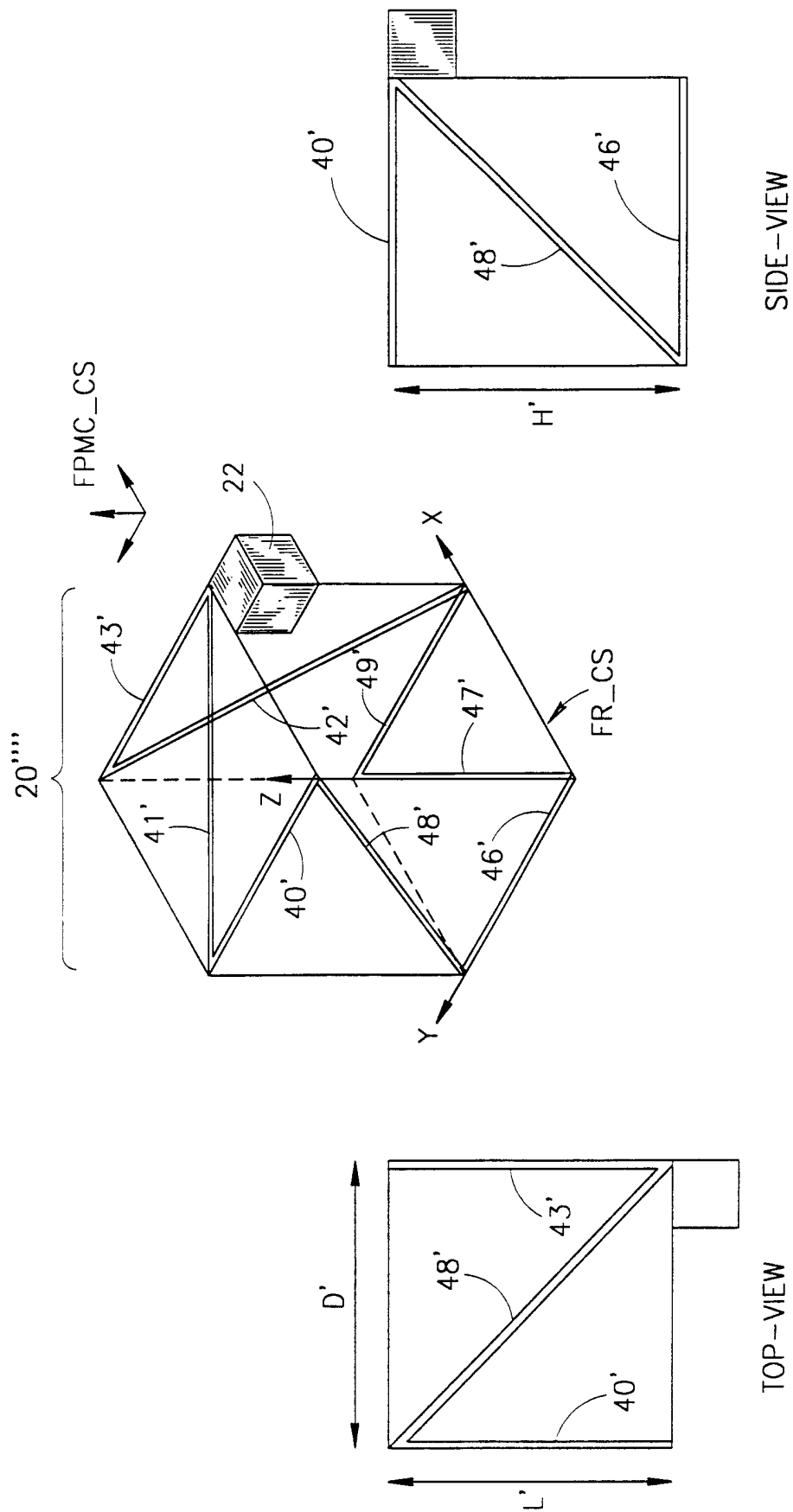

FIG.2D

6/20

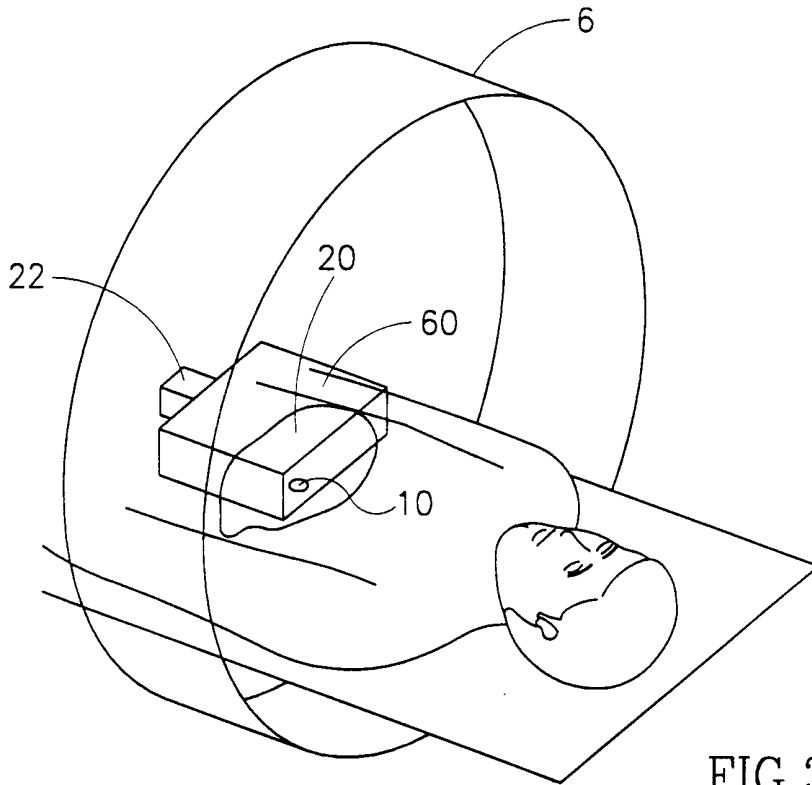

FIG. 3A

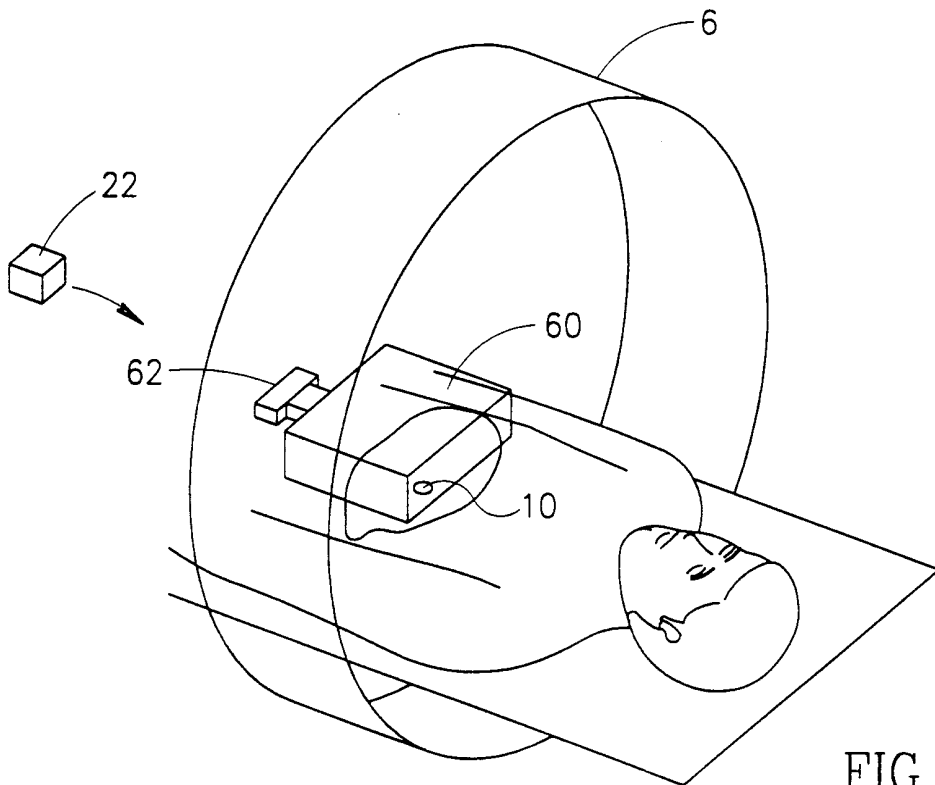

FIG. 3B

CT IMAGE OF
BODY WITH LOCALIZING
DEVICE ATTACHED

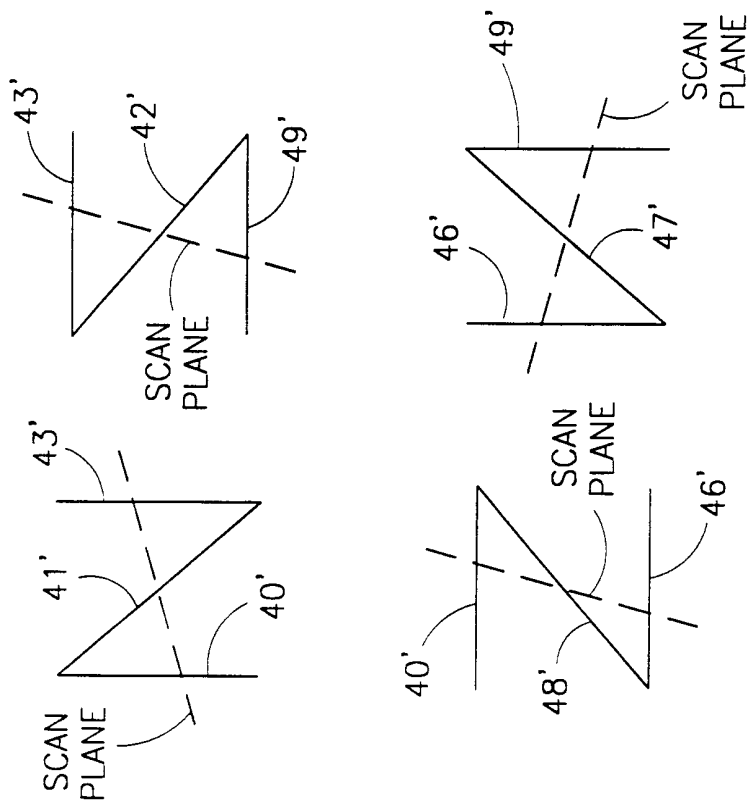
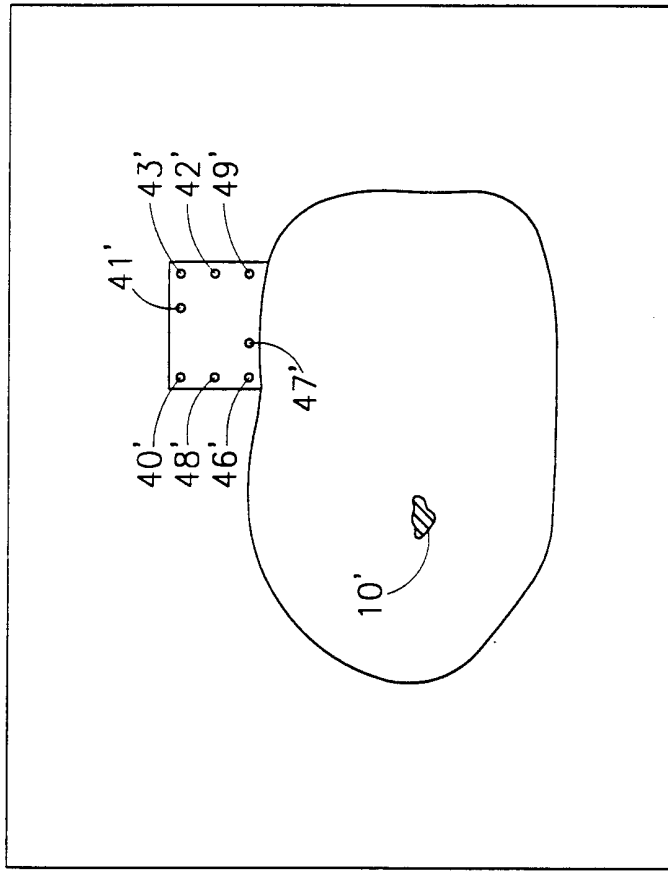

FIG.4

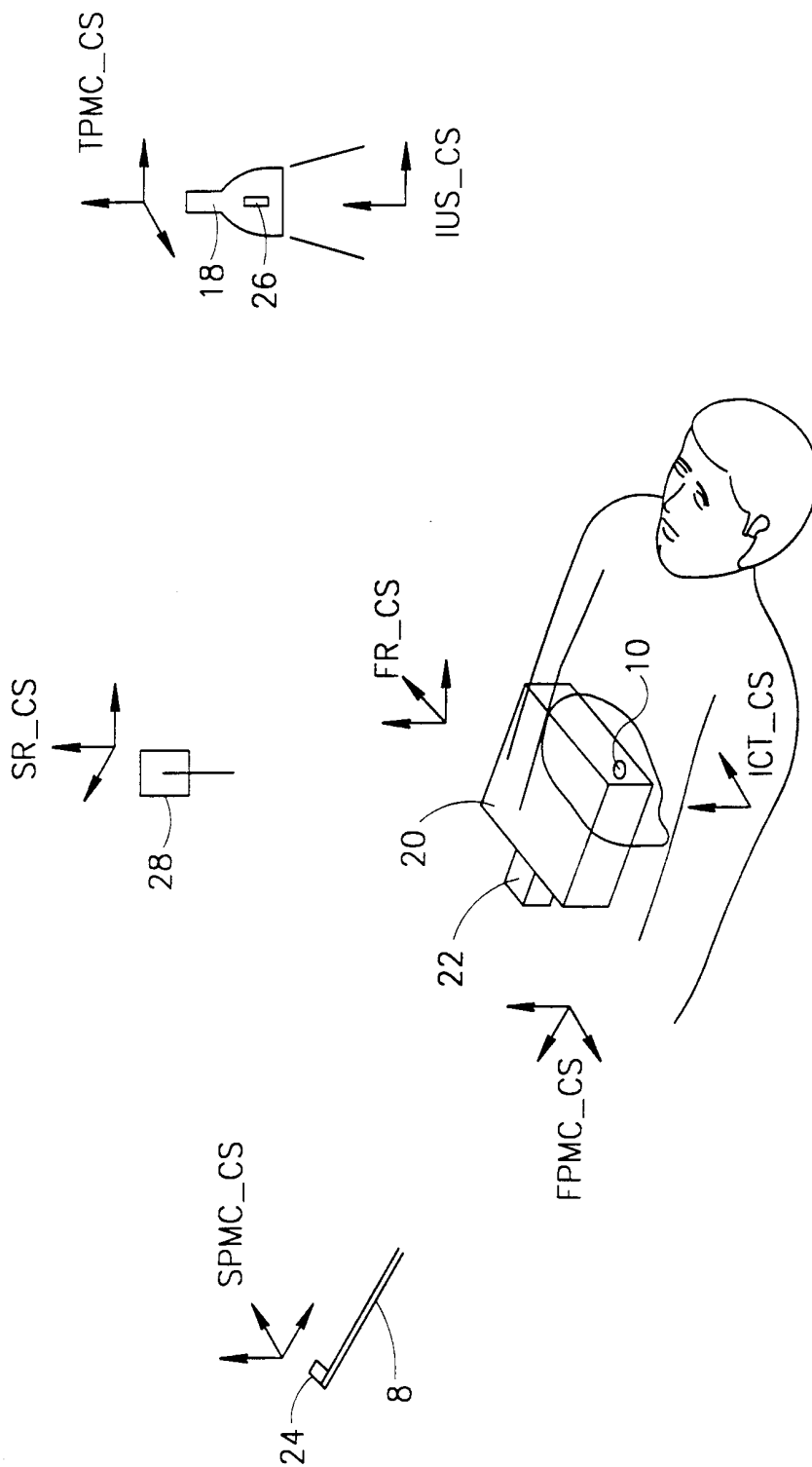

FIG. 5

9/20

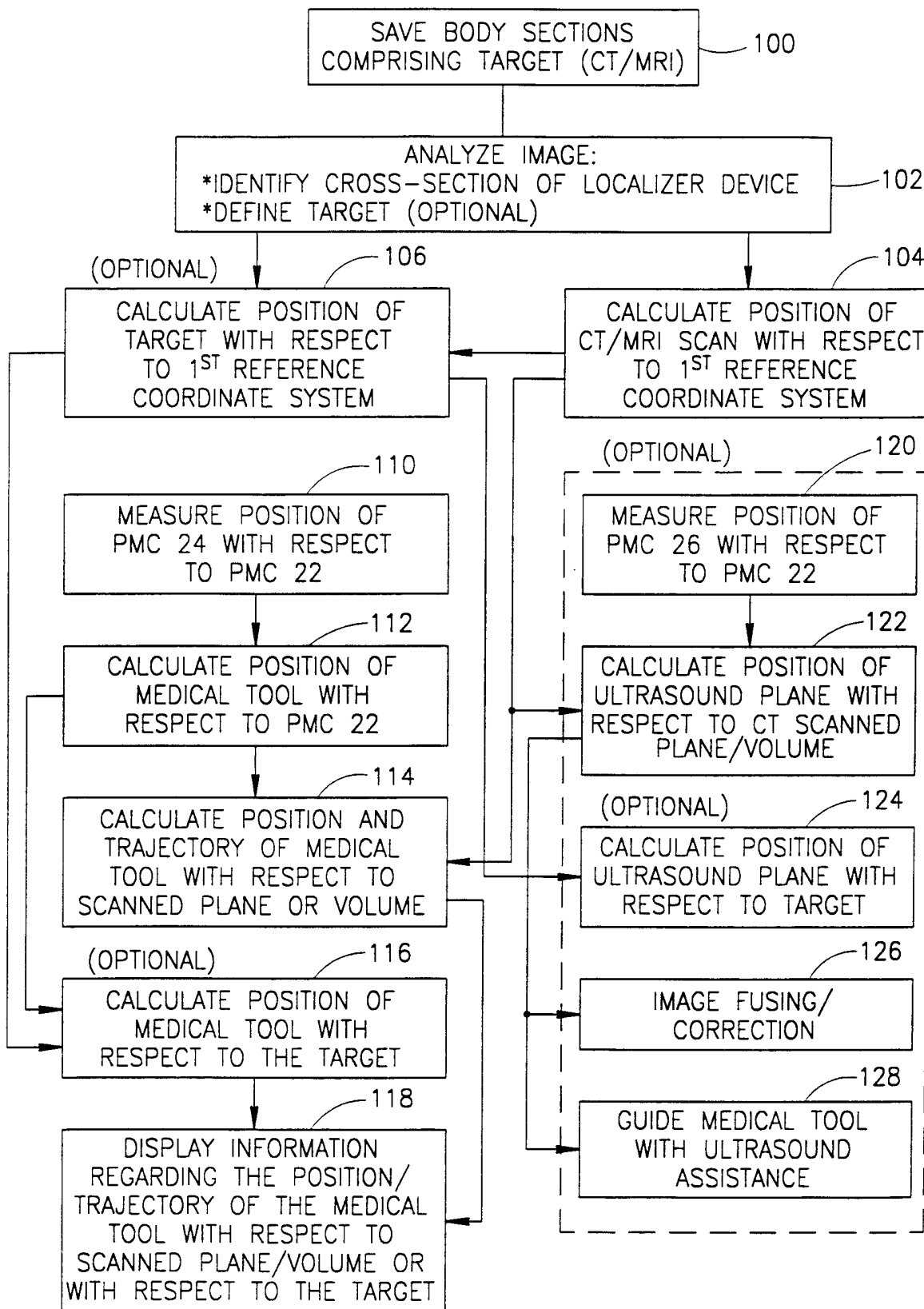

FIG.6

10/20

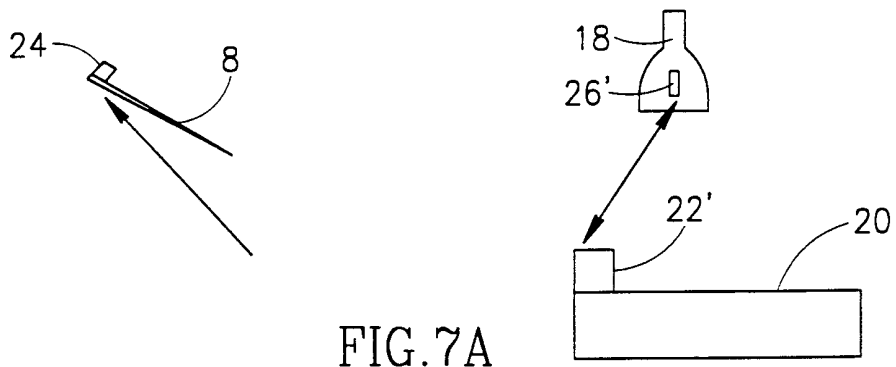

FIG. 7A

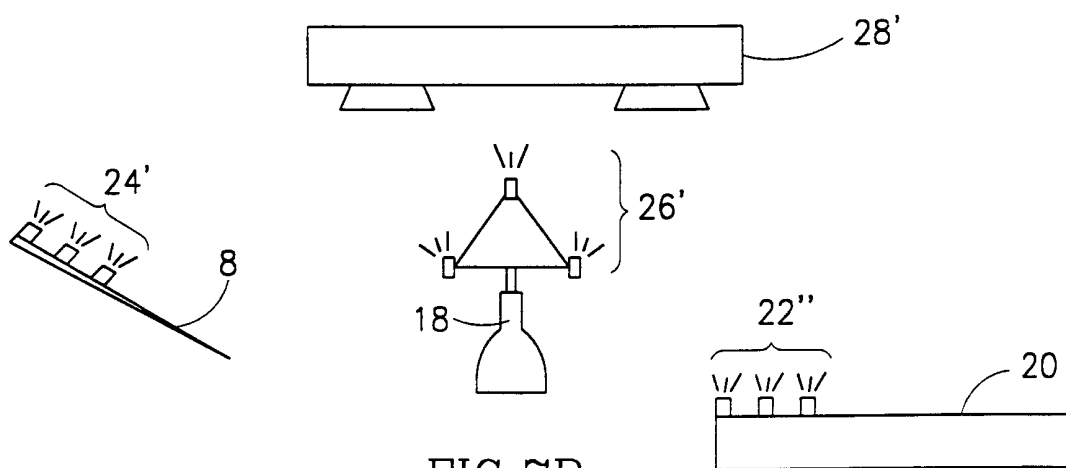

FIG. 7B

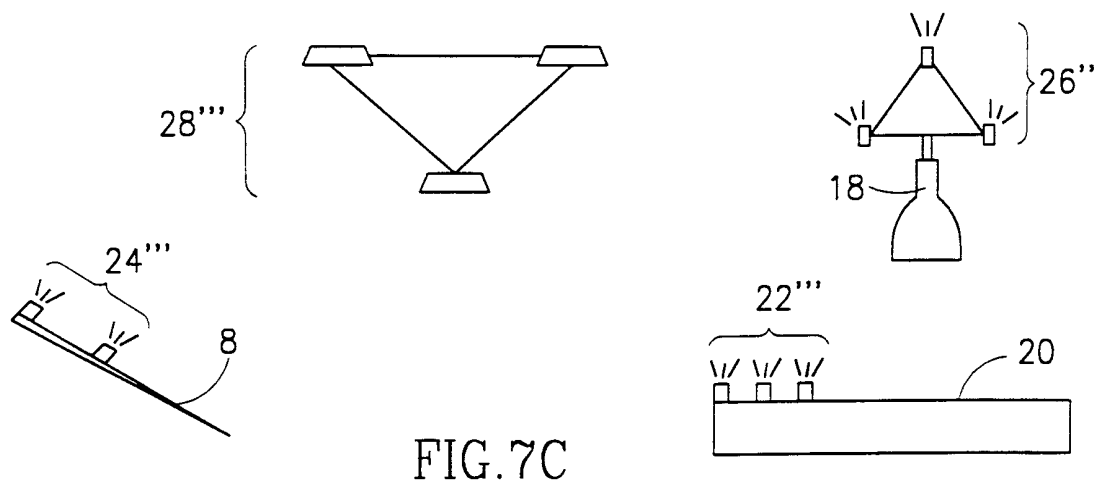

FIG. 7C

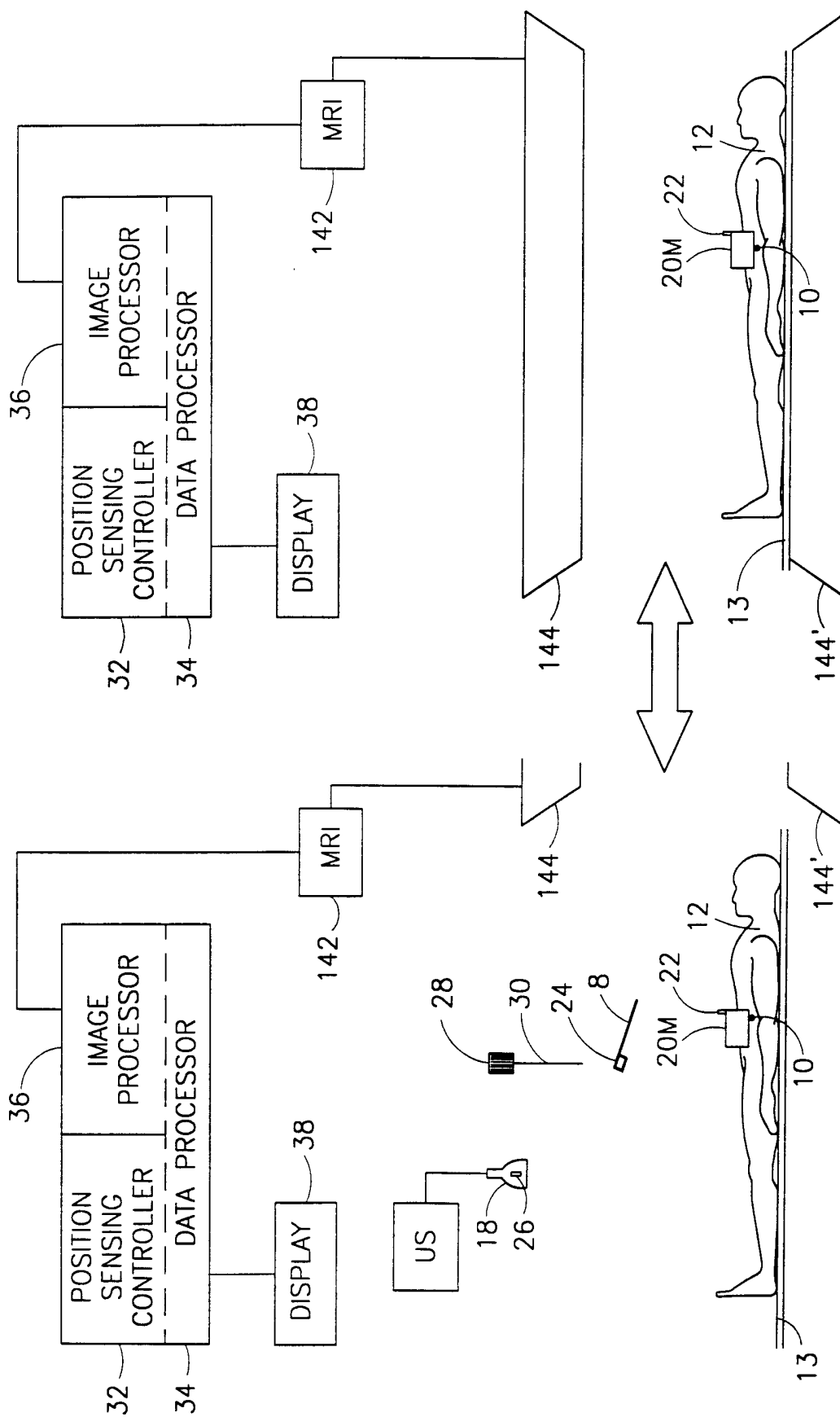

FIG. 8

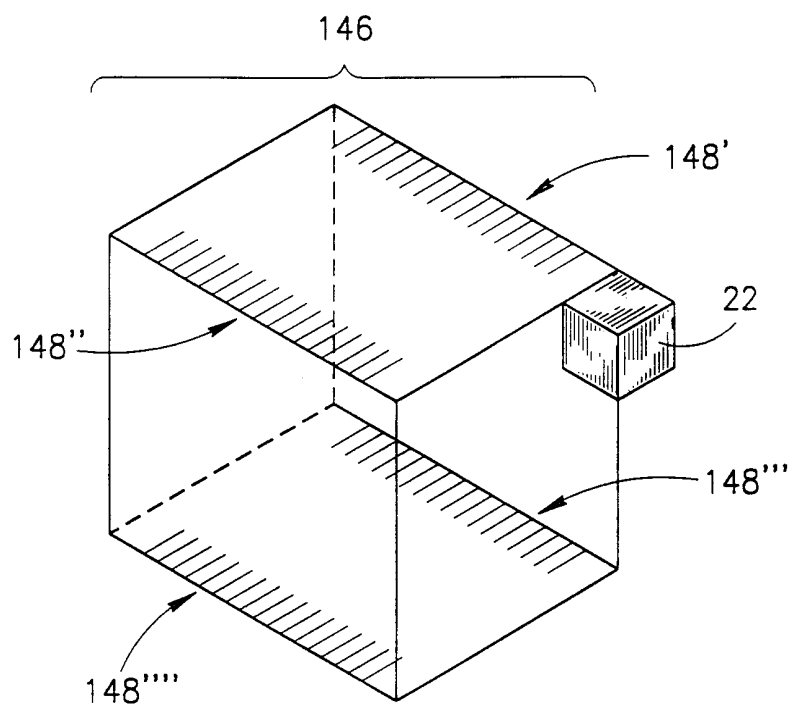

FIG. 9

13/20

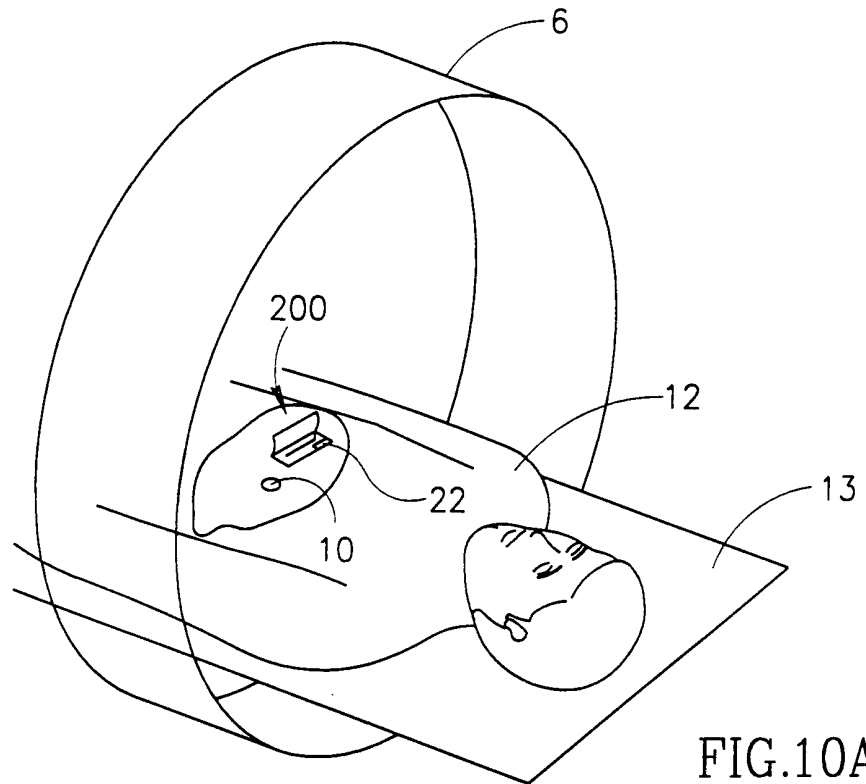

FIG. 10A

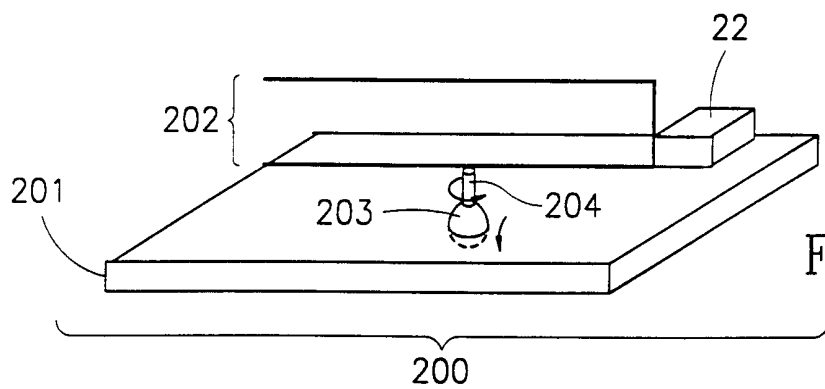

FIG. 10B

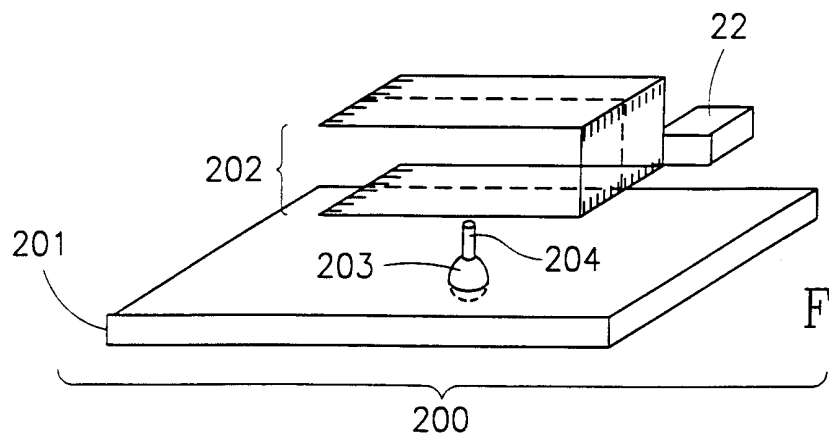

FIG. 10C

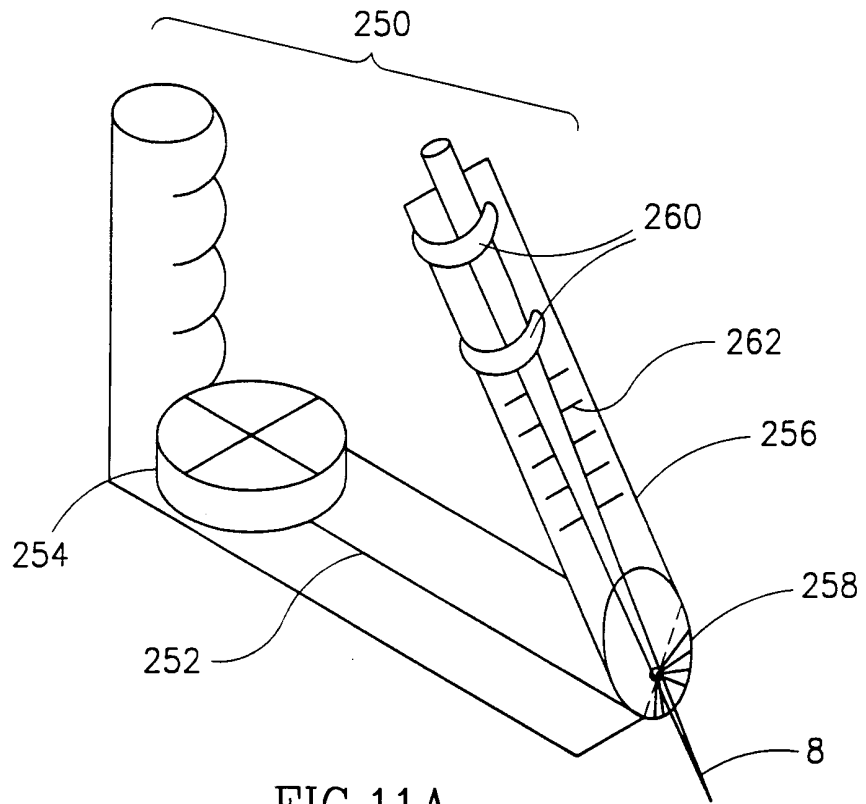

FIG. 11A
(PRIOR ART)

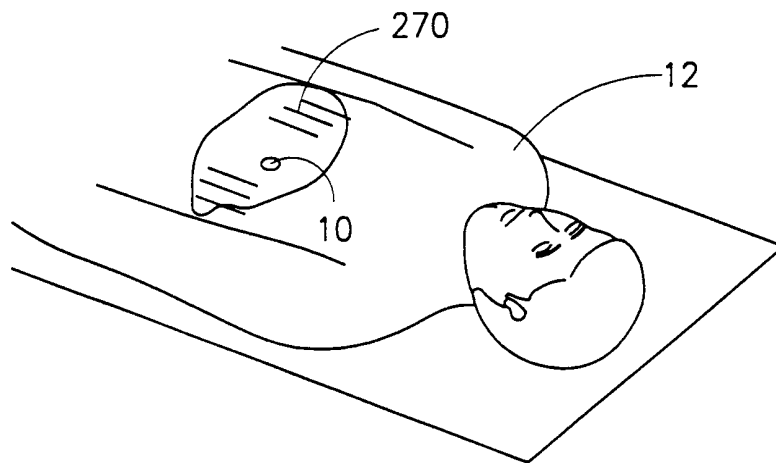

FIG. 11B

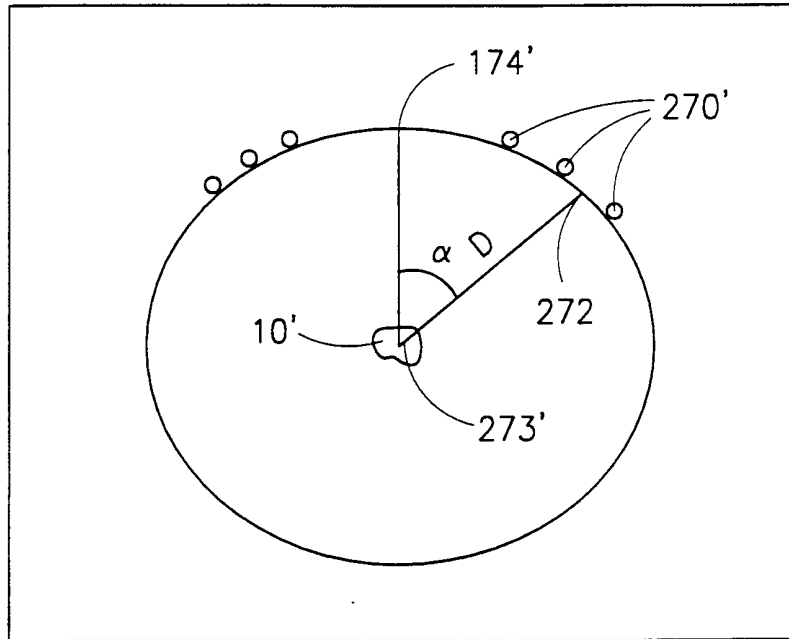

FIG. 11C

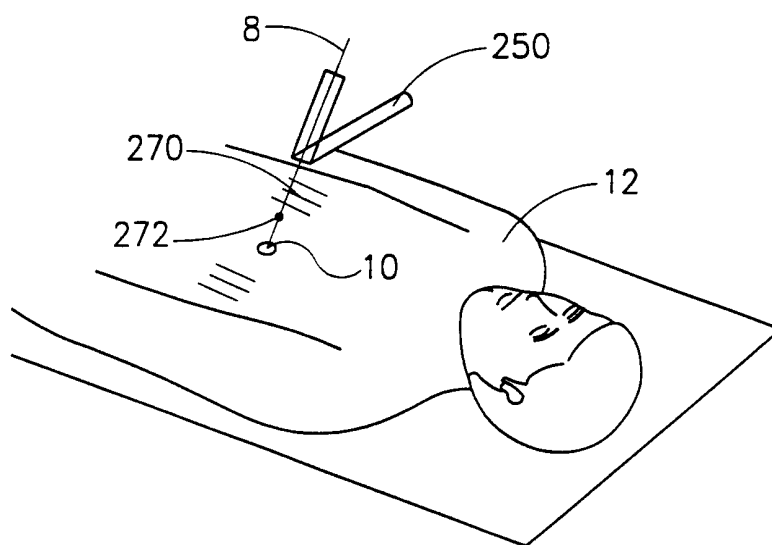

FIG. 11D
(PRIOR ART)

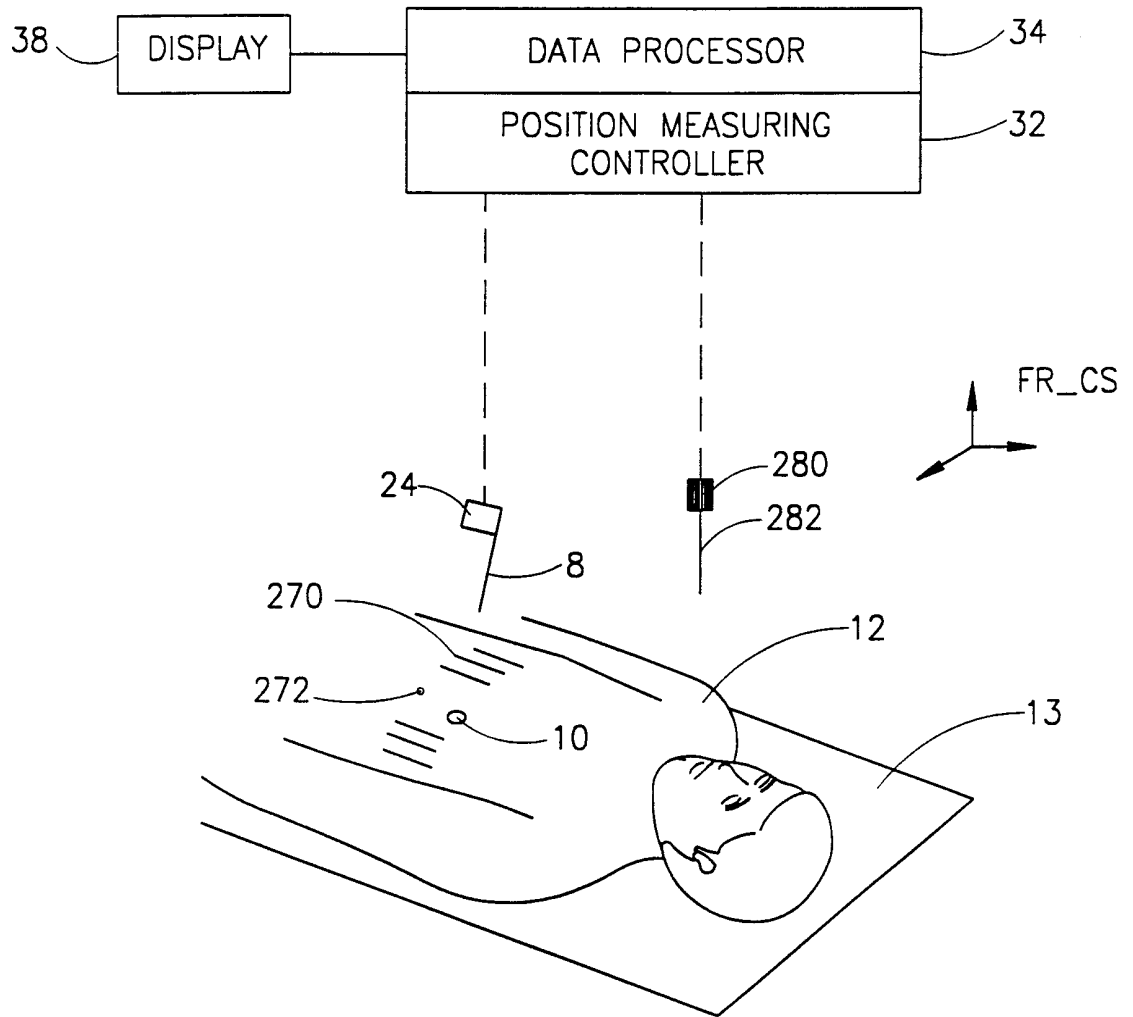

FIG.12

17/20

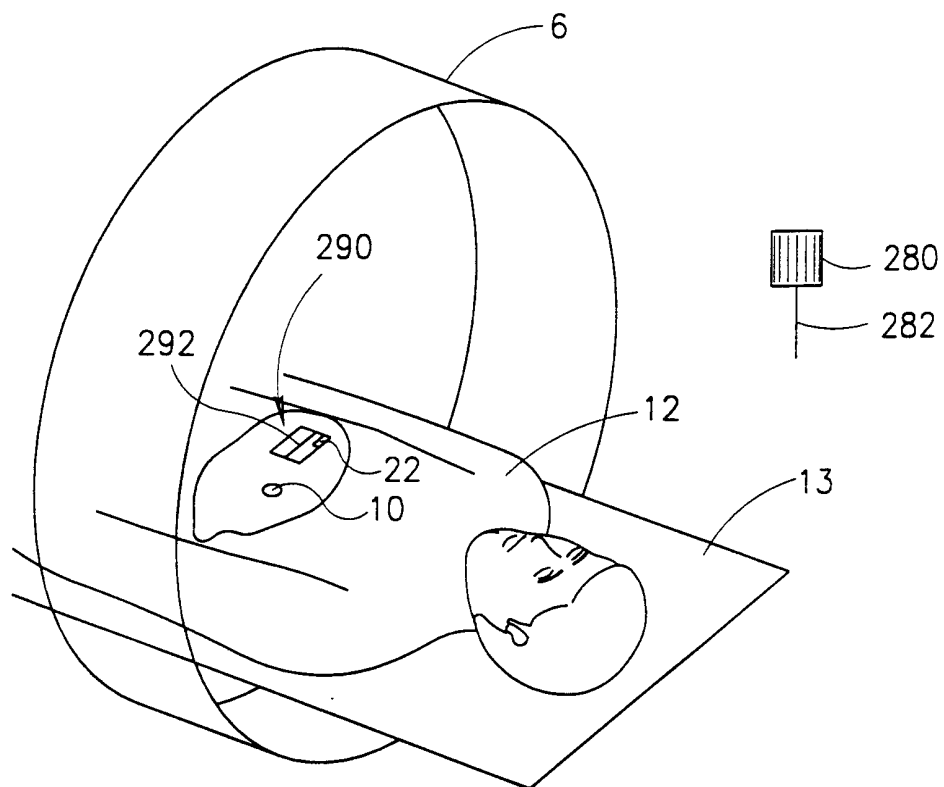

FIG. 13A

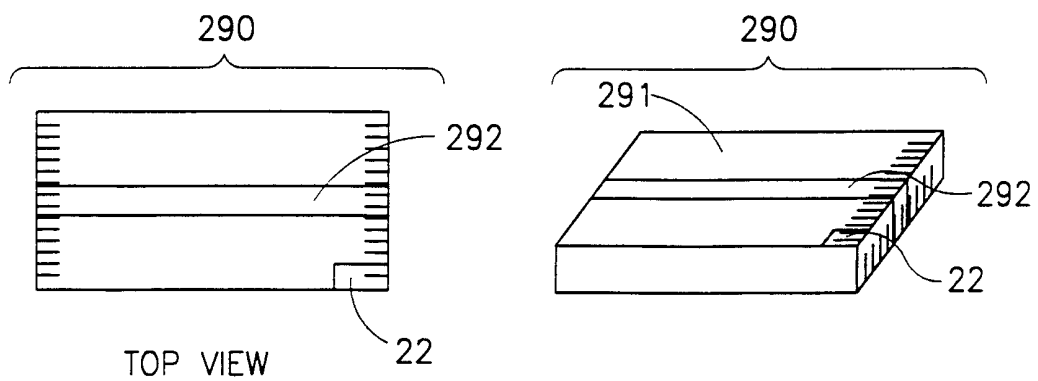

FIG. 13B

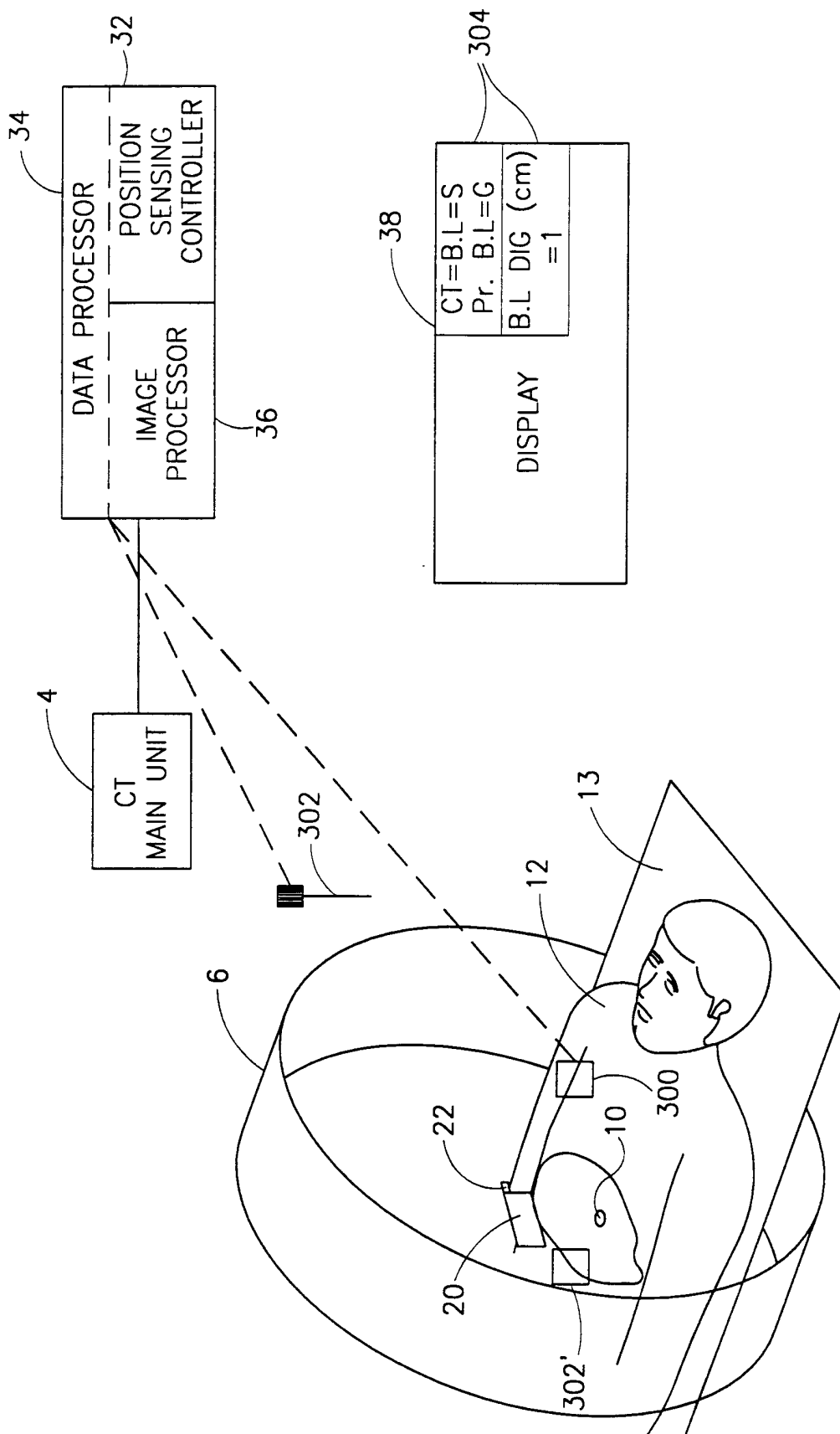

FIG.14

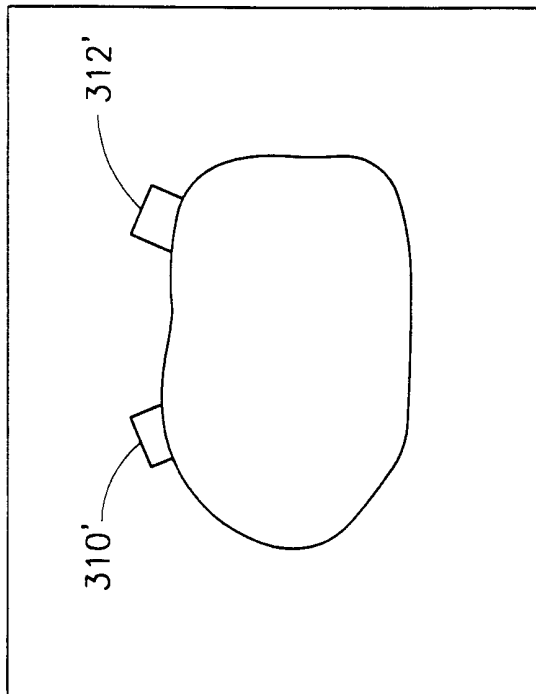

FIG. 15B

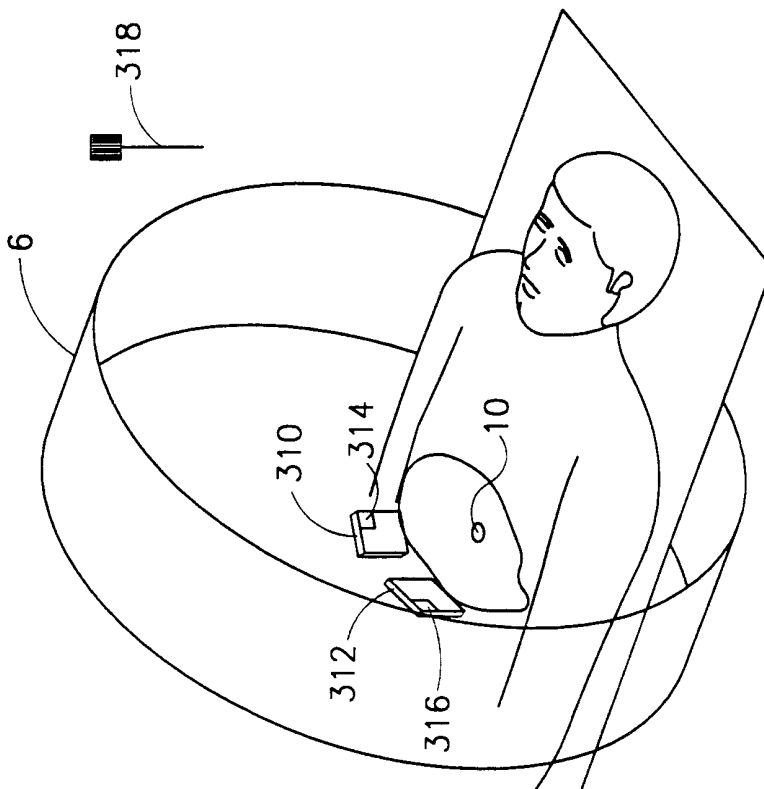

FIG. 15A

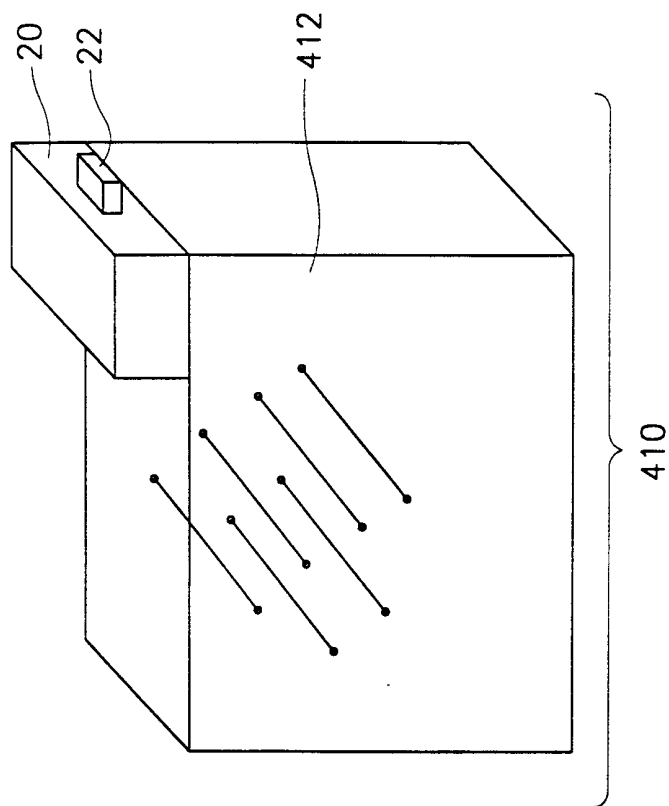

FIG. 17

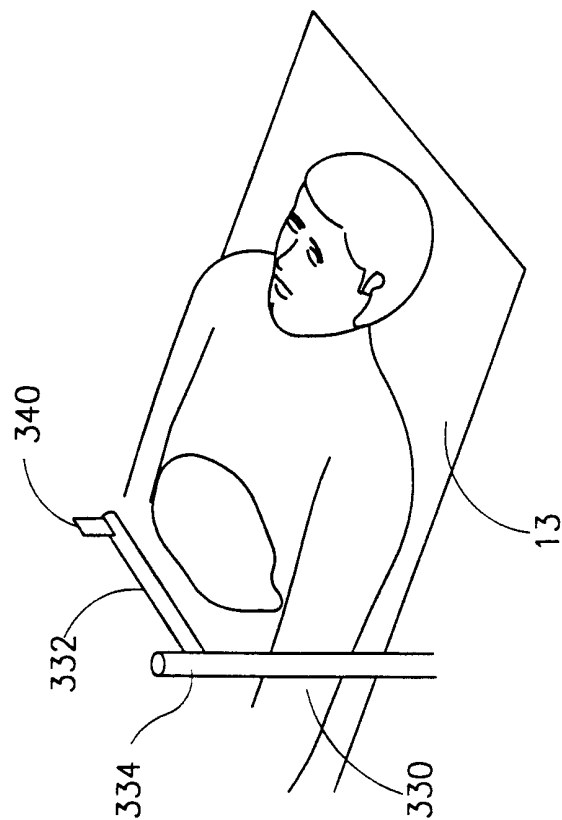

FIG. 16