

(19) World Intellectual Property Organization
International Bureau



(43) International Publication Date
29 December 2010 (29.12.2010)

(10) International Publication Number
WO 2010/149393 A1

(51) International Patent Classification:

A61M 1/10 (2006.01) F04D 29/18 (2006.01)
F04D 3/00 (2006.01) F04D 29/24 (2006.01)

(21) International Application Number:

PCT/EP2010/004023

(22) International Filing Date:

25 June 2010 (25.06.2010)

(25) Filing Language:

English

(26) Publication Language:

English

(30) Priority Data:

09075276.7 25 June 2009 (25.06.2009) EP
61/220292 25 June 2009 (25.06.2009) US

(71) Applicant (for all designated States except US): **ECP ENTWICKLUNGSGESELLSCHAFT MBH** [DE/DE];
Wiesenweg 10, 12247 Berlin (DE).

(72) Inventor; and

(75) Inventor/Applicant (for US only): **TÖLLNER, Thomas** [DE/DE]; Pannierstr. 31, 12047 Berlin (DE).

(74) Agent: **PFENNING, MEINIG & PARTNER GBR**;
Patent- und Rechtsanwälte, Joachimstaler Strasse 12,
10719 Berlin (DE).

(81) Designated States (unless otherwise indicated, for every

kind of national protection available): AE, AG, AL, AM, AO, AT, AU, AZ, BA, BB, BG, BH, BR, BW, BY, BZ, CA, CH, CL, CN, CO, CR, CU, CZ, DE, DK, DM, DO, DZ, EC, EE, EG, ES, FI, GB, GD, GE, GH, GM, GT, HN, HR, HU, ID, IL, IN, IS, JP, KE, KG, KM, KN, KP, KR, KZ, LA, LC, LK, LR, LS, LT, LU, LY, MA, MD, ME, MG, MK, MN, MW, MX, MY, MZ, NA, NG, NI, NO, NZ, OM, PE, PG, PH, PL, PT, RO, RS, RU, SC, SD, SE, SG, SK, SL, SM, ST, SV, SY, TH, TJ, TM, TN, TR, TT, TZ, UA, UG, US, UZ, VC, VN, ZA, ZM, ZW.

(84) Designated States (unless otherwise indicated, for every

kind of regional protection available): ARIPO (BW, GH, GM, KE, LR, LS, MW, MZ, NA, SD, SL, SZ, TZ, UG, ZM, ZW), Eurasian (AM, AZ, BY, KG, KZ, MD, RU, TJ, TM), European (AL, AT, BE, BG, CH, CY, CZ, DE, DK, EE, ES, FI, FR, GB, GR, HR, HU, IE, IS, IT, LT, LU, LV, MC, MK, MT, NL, NO, PL, PT, RO, SE, SI, SK, SM, TR), OAPI (BF, BJ, CF, CG, CI, CM, GA, GN, GQ, GW, ML, MR, NE, SN, TD, TG).

Published:

— with international search report (Art. 21(3))

(54) Title: COMPRESSIBLE AND EXPANDABLE BLADE FOR A FLUID PUMP

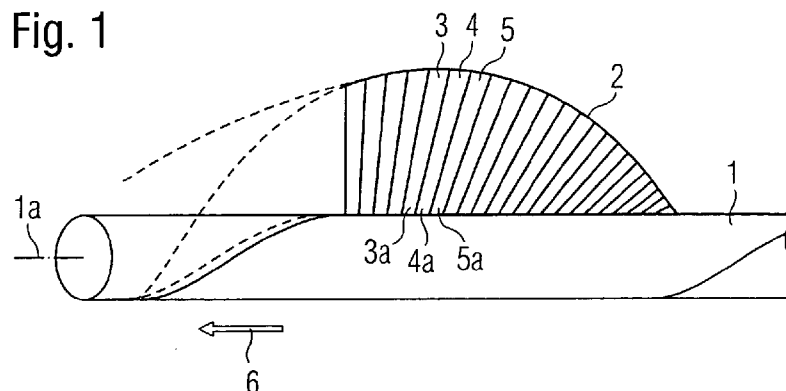

(57) Abstract: The invention relates to a compressible and expandable blade (2) for the rotor of a fluid pump (30) having at least two lamellae (3, 4, 5) which are disposed adjacently, are pivotable respectively relative to an axis of rotation (1a) of the rotor and moveable relative to each other, and abut against each other in the expanded state of the blade such that they form together a continuous blade surface.

WO 2010/149393 A1

Compressible and expandable blade for a fluid pump

The present invention resides in the field of mechanics or micromechanics and can be applied advantageously in particular in medical technology.

The invention relates to a blade for a pump and the design thereof. Of concern thereby is a pump having a rotor, the rotor being compressible and expandable in order to be able possibly to change the overall dimensions of the pump. In this way, the pump can be pushed through not readily accessible openings or into narrow pipe systems, for which purpose it is firstly compressed and, after it has been moved to the location of use, is expanded again.

Such a pump can be used particularly advantageously in medical technology in the field of heart pumps or other pumps for body fluids which are normally used with catheters.

In the technical medical field, different types of micropumps are known, which pumps can be introduced in the compressed state with a catheter through a naturally occurring body vessel into the body of a patient and can be expanded in situ. In order to produce a corresponding radial compressibility and expandability, various effects can be used in the construction and the structure of the pump housing and the pump rotor, such as e.g. the use of so-called memory alloys which change their shape as a function of the ambient temperature or control the pump diameter specifically by providing specific transmission mechanisms which allow it.

A solution is known from DE 10 2004 054 714 A1 in which both the impeller of a micropump and the housing thereof is manipulated by a mutual axial displacement of the pump drive shaft. As a result, the housing is changed between a compressed and an expanded state.

A system is known from the patent document WO 00/2003103745 A2, in which the pump housing is likewise expanded mutually radially by an axial relative movement of two components.

A rotor is known from the US patent specification US 7393181, the blade of which can be subdivided into a plurality of partial blades or rows of partial blades for improved compressibility/collapsibility. As a result of the subdivision, the individual partial blades are smaller than a one-part blade and almost flat so that they can be rolled in easily. However, the ability to be subdivided is restricted by the intrinsic stability of the partial blades which re-

quires to be ensured.

5 With the background of the state of the art, the object underlying the present invention is to produce a rotor which can be produced as simply and economically as possible or a blade for such a rotor, high compressibility being paramount with as little as possible of a force expenditure so that, in order to withdraw the pump from the vessel, the compression of the
10 pump rotor can be achieved without greater external resistances. In addition, the corresponding pump is intended to be designed to be efficient and low-consumption.

15 The object is achieved according to the invention by the features of patent claim 1.

The invention provides a blade having a plurality of lamellae which are disposed adjacently, are moveable
20 relative to each other and pivotable relative to an axis of rotation of the rotor, the lamellae abutting against each other in the expanded state of the blade such that they form together a continuous blade surface.

25 Due to their pivotability, lamellae of this type can be pivoted individually very easily into a space-saving state and, in the pivoted-out, expanded state of the blade or of the rotor, form a closed blade
30 surface which is designed such that it fulfils the required technical flow conditions with respect to shape and surface design.

35 Relative to a collapsible membrane, the blade consisting of individual lamellae has the advantage that its components can, both in the compressed and in the

expanded state, assume a defined shape and arrangement. The individual lamellae can respectively be mounted rotatably on the shaft of the rotor and in fact advantageously pivotable in a plane which includes the longitudinal axis of the rotor shaft or an axis parallel to such a shaft, the mounting points being able to extend around the rotor shaft in a spiral in order to produce a spiral blade in the unfolded state. However, also other types of mounting are conceivable, in which the lamellae are mounted for example on one or more webs or transverse spars which are connected, for their part, to the rotor shaft.

The individual lamellae can be of equal length but can also be designed to be of different lengths according to which final shape the blade is intended to assume. The pivotability of the individual lamellae is restricted so that these, in the opened state, can withstand the flow counterpressure of a fluid to be conveyed. However, the lamellae can also be mutually supported in that they abut against each other and possibly engage in each other forming a lock. For example, the lamellae can be designed in the manner of the elements of a bird feather, the quill of the feather corresponding comparatively to the rotor shaft.

The construction of the blade can be designed such that the blade expands during rotation in the operating direction due to the fluid counterpressure and, when rotating in the opposite direction, is compressed by the effect of the medium in which the blade moves. This makes the compression- and expansion movement particularly simple without greater forces requiring to be overcome. During application

in the medical field, such a pump can hence be removed again in a simple manner and without the danger of damaging body vessels.

5 A particular embodiment of the invention provides that at least two lamellae, in particular each of the lamellae, have per se a dimensionally stable, in particular rigid configuration.

10 The blade obtains its flexibility not from the flexibility of a membrane but from the movability of the individual lamellae relative to each other. For this purpose, the lamellae must not exceed a specific width. Advantageously, the blade for example can
15 consist of at least 10 or at least 50 lamellae. Such a blade can have in total a very small constructional size in order to be inserted into a blood vessel, preferably less than 5 mm for example in the compressed state, a diameter of 2 mm.

20 A further advantageous embodiment of the invention can provide that respectively adjacent lamellae abut against each other to form a seal along a longitudinal side which extends at least partially radially
25 relative to the rotor axis.

If it is even conceivable that the lamellae leave intermediate spaces between themselves, then the efficiency of the fluid pump in fact increases with the seal of the blade formed by the lamellae. It is
30 therefore advantageous if the lamellae abut against each other respectively on their longitudinal side and as far as possible leave no intermediate space there.

35 It can be provided in addition that respectively la-

mellae which are mutually directly adjacent abut
against each other in such a manner that they are not
pivotable relative to each other about the rotor axis
in at least one direction. Hence, the individual la-
5 mellae can support each other mutually and, during
operation, entirely withstand the counterpressure of
the fluid to be pumped. In particular if the lamel-
lae are distributed in a spiral on the circumference
of the rotor shaft, support is provided in the azimu-
10 thal direction.

The invention can be designed in addition such that
respectively adjacent lamellae mutually overlap in
the region of the longitudinal side. As a result of
15 overlapping of the lamellae, particularly high imper-
meability is produced and, in addition, the support
function of the lamellae can be mutually exerted in
the overlapping region.

20 Particularly high stability and impermeability be-
tween the lamellae is achieved in that respectively
adjacent lamellae engage one in the other in the re-
gion of the longitudinal side. Any type of form-
fitting design of adjacent lamellae can thereby be
25 provided, for example respectively the provision of a
fold along the longitudinal sides of the lamellae,
for example also in the form of a thin sealing lip.

In order to produce a form-fitting and sealed connec-
30 tion, it can also be provided that at least one la-
mella, in particular all the lamellae, have a convex
shape, in cross-section, on one of the longitudinal
sides thereof and a concave shape on the other longi-
tudinal side. The corresponding convex or concave
35 structure can, in cross-section, be round, elliptical
or also configured as a groove or notch.

Advantageously, respectively adjacent lamellae can be connected to each other by a flexible element, in particular a strip or a membrane. The ability of the blade to be opened out is then produced in the manner of a fan, in the case of which broad, rigid support bars are connected to each other by narrow membranes or strips.

In order to stabilise the individual lamellae these can respectively have a stiffening structure in cross-section, which provides for example a web extending in the longitudinal direction. However, it can also be provided that, additionally or alternatively, the individual lamellae are configured to be hollow with a round or square cross-section.

Advantageously, the invention can be configured by a blade in which at least two lamellae are connected to each other by a chain-like connection. Such a chain-like connection consists of small hook-like elements on the one side and blade-like elements on the respectively other side, which can be configured advantageously to be microscopically small.

The invention can furthermore be designed advantageously in that the connection is detachable by applying a load on the blade in the axial direction of the rotor and/or by a relative movement of two adjacent lamellae along their respective longitudinal sides and in the longitudinal direction of the lamellae.

The longitudinal direction of the lamellae is thereby dictated by the direction in which the respective lamella extends away from the rotor shaft.

As a result of the described structure of a blade for the rotor of a fluid pump, said blade can be designed to be particularly stable and compressible in a defined manner, as a result of which in particular good compressibility and a small final diameter of the rotor can be achieved in the compressed form.

A development provides that a compressible and expandable blade for the rotor of a fluid pump, in particular a catheter pump, is provided, at least two lamellae which are disposed adjacently being pivotable respectively relative to an axis of rotation of the rotor and being moveable relative to each other and abutting against each other in the expanded state in such a manner that they form together a continuous blade surface, the at least two adjacently-disposed lamellae belonging to different rotor segments, one rotor segment comprising at least one lamella and also a hub segment.

As a result, it becomes possible to construct a rotor "sequentially", layering of individual rotor segments hereby being provided in the axial direction. These rotor segments need not be (but might) welded etc. to each other, it suffices that these are fixed non-rotatably relative to each other. As a result of the fact that the rotor segments have respectively at least one lamella and also one hub segment, the connection to the rotor shaft can be provided by the hub segment or the hub segment can also represent an axial portion of the rotor shaft itself. By means of the combination of different hub segments, an influence can be made on the pitch of the helix. Hence, the economical construction of a helix with an irregular pitch becomes possible, the pitch increasing

advantageously in the conveying direction.

The rotor segments can be made of different materials, for example from shape memory materials, in particular shape memory metals or shape memory plastic materials. In addition to "Nitinol", polymers with the desired properties are hereby possible.

A development hereby provides that the lamellae per se are respectively individually coated and/or covered by a membrane, a connection of the coating/membrane of two adjacent lamellae being at best frictional and/or form-locking. As a result, the advantage of the "bird feather" principle is ensured, on the one hand, that the placing-around of individual lamellae frictionally (in particular when introducing into a lock) is associated with low complexity, however, on the other hand (due to the mutual support effect), a high fluid counterpressure can be produced. As a result of the fact that the individual lamellae per se (or specific groups of lamellae combined) are respectively coated individually or are covered with a membrane, it is achieved that, in the boundary region of a plurality of lamellae/lamella groups, an even better sealing effect is produced, on the one hand, by the coating/membrane and, in addition, better flow-wise or biocompatible adaptation of the blade to the medium to be conveyed (e.g. blood) becomes possible. In addition, this can mean weight and stability advantages since the lamellae per se require for example a metal frame which is then coated or sprayed over with a plastic material membrane or a polymer matrix. This is a significant improvement relative to lamella arrangements in which the entire blade, as a whole, is reshaped with a single membrane or a single spraying-around since such

arrangements, during compression, require higher forces because of the limited deformability of the grouped lamellae.

5 A particularly advantageous development provides that the at least one lamella and also the hub segment of the rotor segment are in one part. This means that these can be produced integrally or from a unified
10 body, preferably a pipe or a flat material (raw material). The thickness of the raw material is preferably 5 μm to 500 μm , more preferably 20 μm to 200 μm .

A development provides that at least two adjacent rotor segments are connected to each other non-
15 rotatably in a form-fit. This can be ensured by corresponding engagement elements (raised portions/depressions). As a result, the mounting is significantly simplified in addition. One development provides that an individual rotor segment has
20 here a single hub element and also one, two (or even more) lamellae. For example, the rotor segment can have an individual lamella, however also a "wing arrangement" is conceivable in which two lamellae (preferably situated one opposite the other) protrude.
25 Various arrangements are possible here, above all according to how much lamella surface area is required. If in particular a lot of lamella surface area is required, a flat material or even a pipe material for
30 example with a large diameter can be chosen, a diameter change then being able to take place later in the region of the hub segment for adaptation to the rotor shaft.

35 A method for the production of a rotor segment or a blade having a plurality of rotor segments provides that structures for hub segments and also lamellae

are cut out (for instance by means of a laser by wire eroding or etching) from a (for instance tubular or flat) basic body, a connection web between hub segment and lamellae remaining in order to ensure the advantages of the one-part state. Subsequently, the lamellae can be plastically deformed in their radially protruding normal state by corresponding shaping tools, as a result of which they correspond to the expanded (but not yet subjected to fluid pressure) state of the subsequent blade. Subsequently, possibly a chemical etching treatment or a further laser treatment of the lamellae can be effected in order to ensure for example smooth or different surfaces in order to influence the technical flow properties of the lamella. For example, also the profile of the lamella can be adapted here to assist the flow.

Hereafter, the rotor segments can subsequently be joined axially to form a rotor shaft. Preferably, these rotor segments, even when a form-fit is provided in advance by complementary concavities/raised portions, are connected to each other by means of material joining methods, for example glueing or welding.

Another development provides that rotor segments with connection webs disposed between the rotor segments can be worked out of a flat material and are to be disposed on a rotor shaft by folding the flat material out of the surface plane in such a manner that automatically a helix shape of the blade is produced.

A further development provides that a plurality of lamellae are part of one lamella body, these being connected to each other merely in their foot region. As a result, again easy collapsibility of the lamel-

lae is achieved since they are not connected in their end region protruding radially from the rotor (in the expanded state) and hence the lamellae can individually be deformed easily.

5

The lamella body can thus be introducible into a hub body such that, in the unloaded state of the outer tips of the lamellae, a helix shape of the blade is formed. For example, the hub body is configured as a shell with spiral longitudinal slots into which the lamella body is introduced so that later the hub body represents the outer circumference of the rotor shaft in the case of a finished catheter pump/fluid pump.

15

A further development provides that the lamella body in the foot region of the lamellae has weak portions in order to achieve higher tangential deflections of the lamellae with the same force application (compared with the state in which there are no weak portions). As a result, good rigidity of the lamella is achieved, on the one hand, relative to the fluid but, on the other hand, sufficient flexibility is ensured during the first deformation of the lamella body into the helix shape.

25

All of the above-mentioned lamella arrangements make it possible to produce catheter pumps for introduction into human vessels, in particular for intraventricular use, a rotor with a blade and the pump having a conveying direction for conveying body fluid and the blade hereby having a flow pressure side and a flow suction side.

35

A development provides that, on the flow pressure side, the proximal region of a distal lamella covers the distal region of an adjacently-situated proximal

lamella. As a result, the type of "stepping" of the lamellae is fixed. The advantage is that a stepping of this kind is very blood-compatible. The erythrocytes do not collide with the step in pumping/flow direction; instead, they "fall down the steps".

In one embodiment it is possible to finish, to coat and/or to extrusion coat/insert mold the single lamellae in a way that (at least in regions) a steady/continuous curvature of the blade on the flow pressure side and/or the flow suction side is given.

A further development provides that application of the lamellae in a compressed state is effected essentially by deflecting the lamellae. This is achieved (for example in an embodiment according to Fig. 13d) in a way that proximally of the rotor a sheath is positioned and the rotor is introduced into the sheath in proximal direction, wherein the lamellae basically one after another (first the most proximal, then the one distally neighboring the most proximal and so on) are bent (i.e. the blades are not bent in total at once, instead the lamellae are bent one after another which has the advantage of lower force requirements). The sheath may have a tube-shape cross-section.

It is also possible to provide a compressible rotor housing etc. between sheath and rotor, without changing the above principle of bending the lamellae one after another. Remark: in the context of the patent application, "bending the lamellae basically one after another" means that especially the beginning (the first phase) of bending of the lamellae happens one after another. In the case of multi-blade rotors, eventually several lamellae having the same axial position are contemporaneously bent.

It may be noted once again that the above-described coating of individual lamellae or groups of lamellae can be effected with a membrane (plastic material- or metal foil) or any other coating.

The invention is shown and subsequently described in the following in a drawing with reference to an embodiment.

There are thereby shown:

- Fig. 1 schematically in a three-dimensional view, a rotor shaft and also a blade,
- Fig. 2 schematically, a part of a blade with a plurality of lamellae,
- Fig. 3 a rotor shaft in cross-section with a lamella in two positions,
- Fig. 4 a rotor shaft in cross-section with two lamellae in respectively two positions,
- Fig. 5 a view of a rotor shaft with four lamellae,
- Fig. 6 a view of a rotor shaft with two configurations of lamellae,
- Fig. 7 a view of a rotor shaft with two configurations of lamellae and also

- Fig. 8 a schematic representation of a heart catheter pump with a rotor and blades in a ventricle,
- 5 Figs. 9 to 12 show schematic 3-dimensional illustrations of overlapping lamellae.
- 10 Figs. 13a to 13l an embodiment of the blades according to the invention, these blades consisting of lamellae of adjacently-situated rotor segments,
- 15 Figs. 14a to 14d embodiments of a blade in which a lamella body is inserted into a spiral incision of a shell body, and also
- 20 Figs. 15a and 15b a further embodiment of a blade which is constructed from rotor segments.

25 Fig. 1 shows a rotor shaft 1 having a blade 2 which is composed of individual, schematically indicated lamellae 3, 4, 5. The individual lamellae are mounted pivotably respectively by their feet 3a, 4a, 5a on the rotor shaft 1, the feet of the lamellae together extending around the rotor shaft 1 in a spiral.

30

In this way, a helical structure of a blade is produced, which effects an axial conveyance of a liquid in the direction of the arrow 6 during rotation about the rotor shaft 1.

35

The particular embodiment of the blade according to the invention emerges in more detail from Fig. 2. In a first position, the lamellae 3, 4, 5 are represented there in the deployed, expanded shape of the blade, the adjacent lamellae abutting closely against each other by their longitudinal sides and hence forming a surface which is smooth and sealed for the flowing fluid.

In the position which is illustrated in broken lines and designated with 7, the individual lamellae are folded a little far onto the rotor shaft 1, it being totally important for the deformability of the blade that the individual lamellae 3, 4, 5 are moveable relative to each other, in particular are displaceable in the longitudinal direction. Consequently, folding of the corresponding surface is unnecessary but the individual lamellae can be folded quite far towards the rotor shaft, as is represented in the further position 8 of the lamellae.

As a result, the blade can be extensively compressed, i.e. can be reduced with respect to the radius, relative to the rotor shaft 1 or the longitudinal axis 1a thereof.

No noteworthy elastic counterforces are thereby produced either so that the rotor can be compressed practically without force if this is required for example for introduction or removal of a corresponding fluid pump from a naturally occurring body vessel.

In Fig. 2, if pivotability of the individual lamellae in the longitudinal direction of the rotor shaft 1 in the plane of the rotor shaft axis is indicated, then the invention is not however restricted hereto. Fig.

3 shows pivotability of a lamella 3 in the azimuthal direction, as indicated by the arrow 9.

Fig. 4 shows a further variant of such an embodiment, webs 10, 11 being provided on the rotor shaft and the lamellae 3, 4 being mounted pivotably on the webs 10, 11 which extend around the rotor shaft 1 in a spiral. The pivoted positions are represented respectively in broken lines in Fig. 4.

It becomes clear that the pivoting of the lamellae in the position illustrated respectively in broken lines leads to compression of the rotor. For example, compression of the rotor can be caused by a rotational operation of the rotor in a direction opposite to the operating direction. The deployment of the rotor takes place correspondingly by rotation in the operating direction.

Basically, the individual lamellae can also be mounted on transverse spars of the rotor shaft 1 and extend in the deployed state parallel to the longitudinal axis of the rotor shaft. It is important that they can be collapsed correspondingly individually in order to reduce the diameter of the rotor.

In Fig. 5, a plan view on four lamellae 12, 13, 14, 15 is shown schematically, said lamellae having respectively, in cross-section, a rectangular and hollow configuration in order to produce greater longitudinal rigidity of the individual lamellae. The objective thereby is that, despite the rigidity of the individual lamellae, the blade in total can be collapsed easily.

Fig. 6 shows two configurations of lamellae, on the

left side respectively lamellae 16, 17 which have an overlapping lip 18, 19 being illustrated, adjacent lamellae respectively forming a seal on the overlapping lip 18, 19 of the adjacent lamella, on the one hand, and being supported, on the other hand. As a result, rigidity of the blade in total is produced so that the blade withstands an increased fluid counter-pressure during operation.

5

10

On the right side of Fig. 6, three lamellae 20, 21, 22 are illustrated, each of the lamellae having a web 20a, 21a, 22a extending in the radial direction of the rotor shaft 1.

15

20

Fig. 7 shows, on left side of the plan view on the rotor shaft 1, three lamellae 23, 24, 25 which have, on one side 26, a convex protuberance and, on the other side 27, a concave depression in order that adjacent lamellae engage one in the other and thus can be mutually supported relative to an azimuthal pivoting position.

25

Lamellae 28, 29 are illustrated on the right side of Fig. 7, each of the lamellae having, on their longitudinal sides, a concave and a convex protuberance with a round cross-section. This design has the advantage that adjacent lamellae are rotatable about their longitudinal axis in a mutually restricted manner.

30

35

Basically, the individual lamellae can be mounted on the rotor shaft 1 either by means of a pivoting articulation or have a bendable or flexible configuration in their foot region such that they are pivotable in any case as a whole relative to the rotor shaft. The individual lamellae can also be glued by their foot

ends respectively individually on a flexible strip or can be mounted on the latter in a different way, the strip with the lamellae being able as a whole to be mounted on the rotor. As a result of the flexibility of the strip, the pivotability of the individual lamellae can then be ensured.

In Fig. 8, the use of a fluid pump with a blade according to the invention is represented schematically, the pump 30 being positioned in a ventricle 31 and, as indicated by the arrows 32, sucks in blood which is conveyed into a vessel 33, as is shown by the arrows 34. The pump 30 is mounted on a catheter 35, through which a shaft 1 illustrated only in the region of the pump 30 extends centrally and is actuated rotationally by means of a motor 36. The shaft moves a rotor 37 which has a blade, illustrated merely schematically.

The pump 30 in the expanded state has a diameter which can be possibly also be greater, in the extreme case, than the inner diameter of the vessel 33. For this purpose, the impeller is expanded fully. However, it can also be compressed in order to introduce or remove the pump 30, the individual lamellae, as illustrated above, being able to be folded against the rotor shaft 1 and, at the same time, the housing of the pump 30 being correspondingly collapsed. For this purpose, this housing can for example consist of a membrane which is deployed by a frame or by the fluid pressure produced in the pump 30.

Figure 9 shows three flat lamellae which overlap at their longitudinal sides and can have for example a burr-like connection in their overlapping region.

Figure 10 shows lamellae which have edges angled by 90 degrees along their longitudinal sides respectively and with which they hook one into the other, whilst a variant, in Figure 11, is illustrated with an angle of less than 90 degrees which likewise allows fixing of the lamellae relative to each other.

Figure 12 finally represents a variant with a curved edge which serves for the same purpose of mutual fixing.

Figure 13a shows a rotor segment 40 which consists of a hub segment 46 and also a lamella 43 connected thereto in one part. The rotor segment is produced from a pipe material, the hub segment 46 essentially still having the diameter of the pipe (of concern hereby is also a ring closed in regions) and the lamella being bent therefrom. For this purpose, the lamella is cut out firstly in its original form by means of a laser beam and subsequently plastic deformability on a moulded body is achieved in which the deformation state shown in Figure 13a is produced. Subsequently, the result is also an etching treatment and for other surface treatment of the lamellae. In order to produce a final blade (see Figure 13c), a plurality of rotor segments are then disposed axially relative to each other.

Also an individual lamella can hereby be covered with a plastic material or metal foil/membrane or also can be sprayed-around and/or molded in order to achieve a greater surface.

Figure 13b shows another view of the rotor segment 40, it can be seen here how tension relieving slots 54 are shown in the foot region of the lamella 43.

It can be seen that the rotor segment shown in Figure 13a/13b has a closed annular shape in the lower region of the hub segment. In addition, it can be seen that the rotor segment connects the hub segment and also the lamella in one part.

Figure 13d shows a further embodiment of a rotor segment which is cut from a pipe material and is not yet completely finished, in the case of which rotor segment the lamellae 43, 43a are not yet spread out. Here also, tension-relieving slots 54 can however already be seen, in particular also form-fitting elements 47 in the form of raised portions can be seen, which can engage in corresponding depressions of axially adjacent rotor segments in order hence to fix the position of the lamellae (later radially spread out).

A rotor with a blade 42 according to the invention is shown in detail again in Figure 13d. The preferred conveying direction of the rotor is hereby characterised by the right-side rotational arrow, it consequently results that the flow pressure side 51 and the (opposite side of the lamellae) is the flow suction side 52. Here a plurality of rotor segments 40 is disposed axially adjacently by their respective hub segments 46. There is consequently produced also a stepping of the adjacent lamellae 43, 44, 45 which are disposed on a rotor shaft 41. This rotor shown in Figure 13d can be part of a fluid pump shown in Figure 8, in particular an intraventricular catheter pump. This is a catheter pump for introduction into human vessels, the rotor with a blade being disposed in the distal end region of the catheter pump and the pump having a conveying direction for conveying body fluid from distal to proximal and the blade having a

flow pressure side 51 (see above) and a flow suction side 52.

5 It can be readily seen in Figure 13d that, on the flow pressure side 51, the proximal region of the distal lamella 44 covers the distal region of the proximal lamella 43. The result consequently is formation of a closed blade, at least in the radial outer region of the lamellae. The lamellae are hereby
10 configured "in the shape of an ice hockey stick". Consequently a very good overlap in the relevant flow region is produced, in addition good collapsibility. Finally, even with a high fluid counterpressure, only a small flow loss results due to the above-mentioned
15 orientation of the stepping of the lamellae.

In addition, it is shown in Figure 13d that application of the lamellae 43, 44, 45 in a compressed state is effected essentially by deflecting the lamellae in
20 the direction of the flow pressure (see arrow 53). This arrow is shown once in the distal and once in the proximal region of the rotor. The "ice hockey stick-shaped" design of the lamellae offers the advantage in addition that, when inserting into a lock
25 situated proximally of the rotor, a low-force and entanglement-free insertion of the rotor is produced.

Figure 13e shows a further embodiment of a rotor according to the invention in which two blades 42 and
30 42a are provided. The rotor shown in Figure 13e is a combination of a plurality of rotor segments according to Figure 13c.

Figure 13f shows a combination of three rotor segments 40 which form parts of a rotor shaft 41, also
35 three hub segments are hereby disposed in succession,

a common blade 42 is produced.

Figure 13g shows a simple embodiment of a rotor segment 40 with two lamellae protruding radially therefrom. Figures 13h shows further embodiments of rotors according to the invention. Figure 13i and 13j again show the rotor segment shown in Figure 13c, here once again the tension-relieving slots 54 and also the form-fitting end serving for the form-fit being shown even better with 47 (raised portion) and also 48 (concavity).

Figure 13k shows a blade 42 on a rotor shaft 41, Figure 13l shows two photographs in which, in the left picture, a blade 42 made of a plurality of lamellae is drawn into an insertion lock 55, the rotor shaft 41 can be seen on the right side. In the right-side picture, the blade 42 is completely inserted in the insertion lock 55.

Figure 14a shows a further embodiment of a rotor in which a hub body 50 has two spiral slots (see Figure 14b) into which a lamella body 49 (see Figure 14c) is inserted. The view of a flat material from which the lamella body 49 is cut by means of a laser can be seen in Figure 14d. For clarification, a possible spraying-around/covering of a lamella is also shown once again in Figures 14d and/or 15a (with cross hatching). The cross hatching can, in another embodiment, be understood that the entire cross-hatched area is made of flat material.

In Figures 15a and 15b, a further embodiment of a blade is shown. A lamella basic body 49 is hereby cut from a flat material, connection struts being provided between individual rotor segments. In that

the individual rotor segments are tilted out of the surface plane and recombined with each other, a helical structure is then produced automatically. This functions for example in such a manner that, according to Figure 15a, the rotor segment disposed on the left side is rotated out of the plane and placed on the next element from the left (and so on for the other rotor elements) such that the openings of the hub segment overlap each other. If these hub segments are then disposed on a common rotor shaft, a helical arrangement of the lamellae 42, 43, 44 is produced automatically. The lamellae may, in a subsequent forming process, be rotated in respect of their longitudinal axis in order to achieve overlapping of the lamellae.

ECP Entwicklungsgesellschaft mbH

107PCT 1433

Claims

5

1. Compressible and expandable blade (2) for the rotor of a fluid pump, characterised by at least two lamellae (3, 4, 5, 12, 13, 14, 15, 16, 17, 20, 21, 22, 23, 24, 25, 28, 29) which are disposed adjacently, are pivotable respectively relative to an axis of rotation (1a) of the rotor and moveable relative to each other, and abut against each other in the expanded state such that they form together a continuous blade surface.
10
15
2. Blade according to claim 1, characterised in that at least two lamellae (3, 4, 5, 12, 13, 14, 15, 16, 17, 20, 21, 22, 23, 24, 25, 28, 29), in particular each of the lamellae, have per se a dimensionally stable, in particular rigid, configuration.
20
3. Blade according to claim 1 or 2, characterised in that respectively adjacent lamellae (3, 4, 5, 12, 13, 14, 15, 16, 17, 20, 21, 22, 23, 24, 25, 28, 29) abut against each other to form a seal along a longitudinal side which extends at least partially radially relative to the rotor axis (1a).
25
4. Blade according to claim 2 or 3, characterised in that respectively lamellae which are mutually directly adjacent (16, 17, 20, 21, 22, 23, 24, 25, 28, 29) abut against each other in such a manner that they are not pivotable relative to
30

each other about the rotor axis (1a) in at least one direction.

- 5 5. Blade according to claim 3 or 4, characterised in that respectively adjacent lamellae (16, 17) mutually overlap in the region of the longitudinal side.
- 10 6. Blade according to claim 3 or 4, characterised in that respectively adjacent lamellae (23, 24, 25, 28, 29) engage one in the other in the region of the longitudinal side.
- 15 7. Blade according to claim 1 or one of the following, characterised in that respectively adjacent lamellae (3, 4, 5, 12, 13, 14 15, 16, 17, 20, 21, 22, 23, 24, 25, 28, 29) are connected to each other by a flexible element, in particular a strip or a membrane.
- 20 8. Blade according to claim 1 or one of the following, characterised in that at least one of the lamellae (20, 21, 22) has a stiffening structure (20a, 21a, 22a) in cross-section.
- 25 9. Blade according to claim 8, characterised in that at least one lamella (20, 21, 22), on its outer side, has at least one stiffening web (20a 21a, 22a) extending in its longitudinal direction.
10. Blade according to claim 8, characterised in that at least one lamella (12, 13, 14, 15) has a hollow configuration in cross-section.
- 30 11. Blade according to claim 8, 9 or 10, characterised in that at least one lamella (28, 29) has a convex shape, in cross-section, on one of the

longitudinal sides thereof and a concave shape on the other longitudinal side.

- 5 12. Blade according to claim 1 or one of the following, characterised in that at least two lamellae (3, 4, 5, 12, 13, 14, 15, 16, 17, 20, 21, 22, 23, 24, 25, 28, 29) are connected to each other by a burr-like connection.
- 10 13. Blade according to claim 12, characterised in that the connection is detachable by applying a load on the blade in the axial direction of the rotor.
- 15 14. Blade according to claim 12, characterised in that the connection is detachable by the relative movement of two adjacent lamellae (3, 4, 5, 12, 13, 14, 15, 16, 17, 20, 21, 22, 23, 24, 25, 28, 29) along their respective longitudinal sides and in the longitudinal direction of the lamellae.
- 20 15. Blade according to one of the preceding claims, characterised in that the at least two adjacent-ly-disposed lamellae (43, 44, 45) belong to different rotor segments (40), one rotor segment (40) comprising at least one lamella and also one hub segment (46).
- 25 16. Blade according to claim 15, characterised in that the at least one lamella (43, 44, 45) and also the hub segment (46) of the rotor segment (40) are in one part.
- 30 17. Blade according to one of the claims 15 or 16, characterised in that respectively two adjacent-ly-situated rotor segments (40) are connected to each other non-rotatably in a form fit.

18. Blade according to one of the claims 15 to 17, characterised in that respectively one rotor segment has one, two or more lamellae (43, 44, 45).
- 5 19. Method for the production of a blade according to one of the claims 15 to 18, characterised in that structures for hub segments (46) and also lamellae (43, 44, 45) are cut out (preferably by means of a laser or by wire eroding) from a
10 (preferably tubular) basic body, a connection web between hub segment (46) and lamellae (43, 44, 45) remaining, subsequently at least the lamellae being plastically deformed in a radially protruding state and/or being heat-treated, furthermore subsequently possibly a surface treatment of the lamellae being implemented, then
15 subsequently the rotor segments (40) being joined axially to form a rotor shaft (41) and possibly fixing of the rotor segments (40) being
20 effected, preferably by means of welding, particularly preferably by means of laser welding.
20. Blade according to one of the claims 1 to 14, characterised in that rotor segments with connection webs disposed between the hub segments
25 can be worked out of a flat material and can be disposed on a rotor shaft by folding the flat material out of the surface plane in such a manner that a helix shape of the blade is produced.
- 30 21. Blade according to one of the claims 1 to 14, characterised in that a plurality of lamellae (43, 44, 45) are part of one lamella body (49), these being connected to each other merely in their foot region.

- 5 22. Blade according to claim 21, characterised in that the lamella basic body (49) can be introduced into a hub body (50) such that, in the unloaded state of the radially outer tips of the lamellae, a helix shape of the blade is formed.
- 10 23. Blade according to one of the preceding claims, characterised in that the lamellae (3, 4, 5; 43, 44, 45) per se are respectively coated and/or covered with a membrane, a connection of the coating/membrane of two adjacent lamellae being at best frictional and/or form-locking.
- 15 24. Blade according to one of the previous claims, characterised in that, on the flow pressure side (51), the proximal region of the distal lamella covers the distal region of the proximal lamella.
- 20 25. Blade according to one of the previous claims, characterised in that application of the lamellae (43, 44, 45) in a compressed state is possible essentially in a serial manner, beginning with the most proximal lamella.
- 25 26. Catheter pump for introduction into human vessels, in particular for intraventricular use, having a rotor with a blade (2; 42) being able to be disposed in a mammalian vessel, characterised in that the pump has a conveying direction for conveying body fluid and the blade hereby has a flow pressure side (51) and a flow suction side (52) and also comprises a blade according to one of the preceding claims.
- 30

Fig. 1

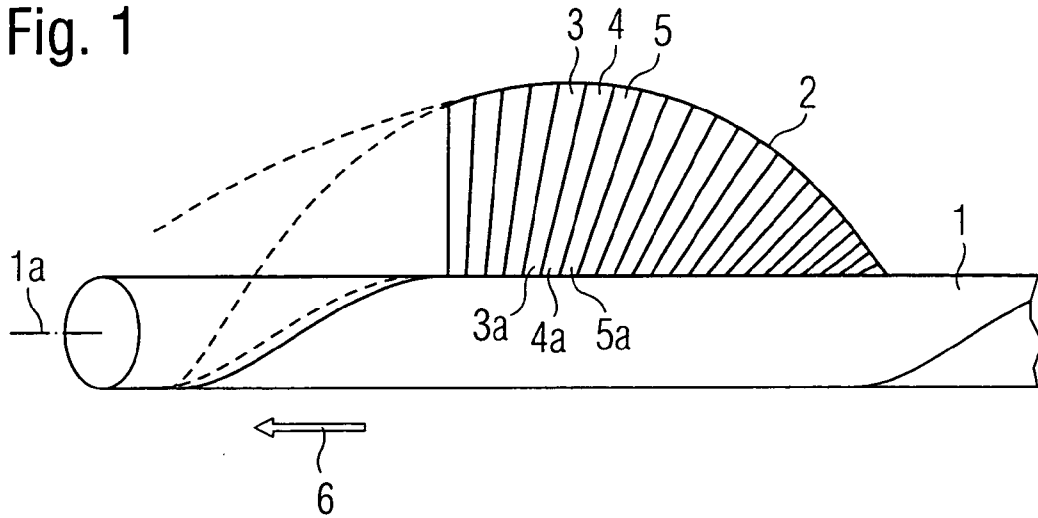

Fig. 2

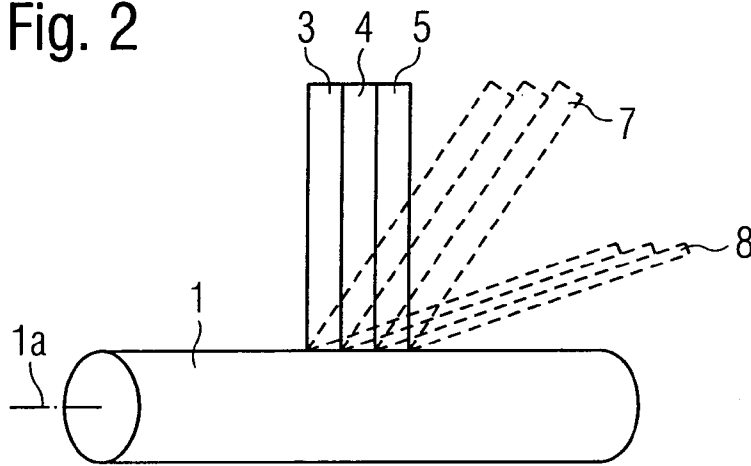

Fig. 3

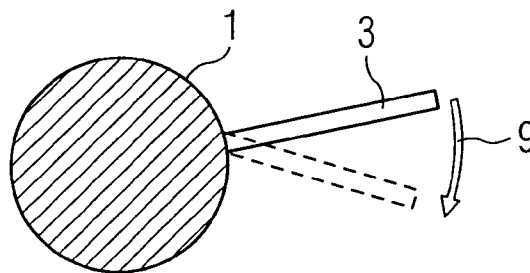

Fig. 4

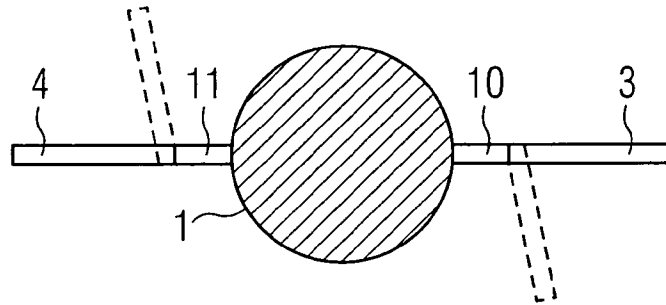

Fig. 5

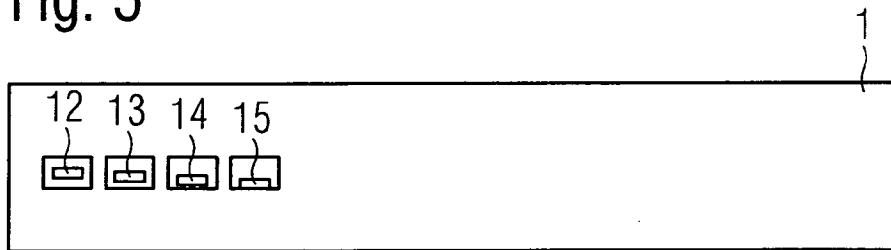

Fig. 6

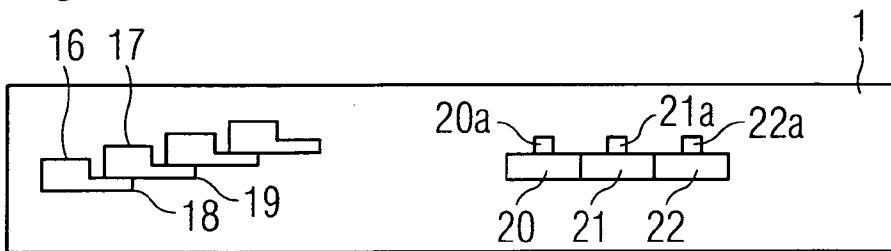

Fig. 7

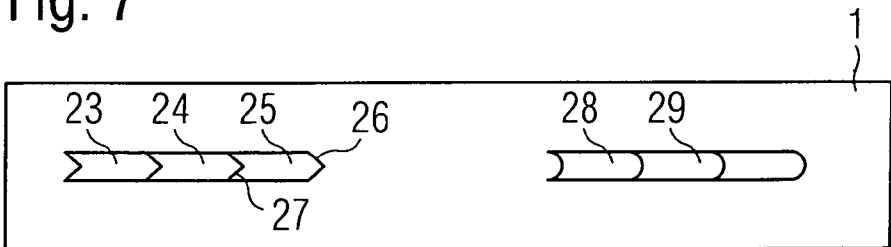

Fig. 8

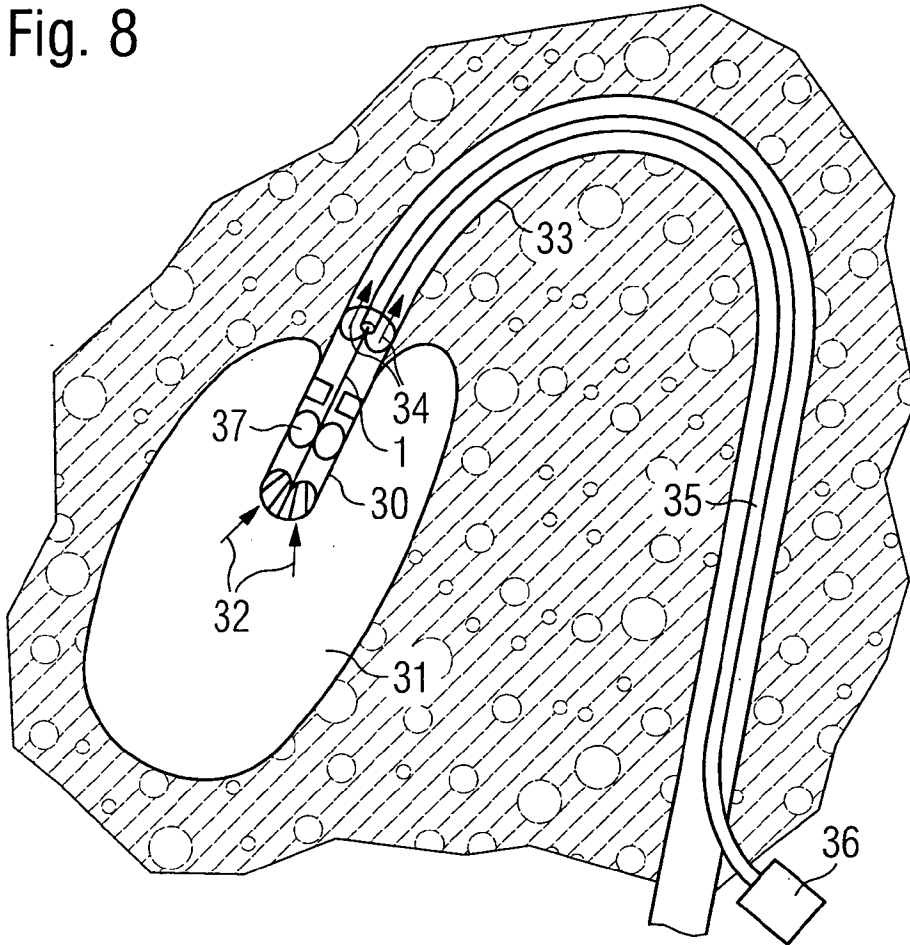

Fig. 9

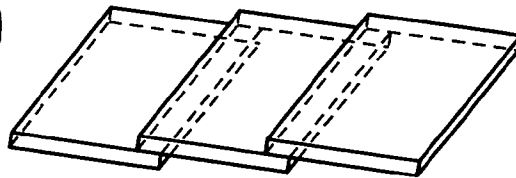

Fig. 10

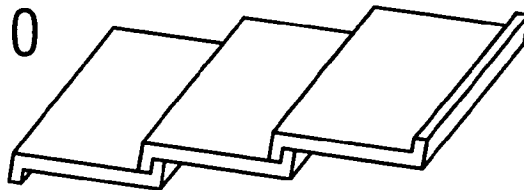

Fig. 11

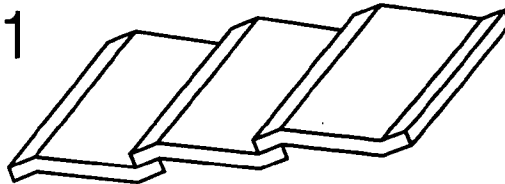
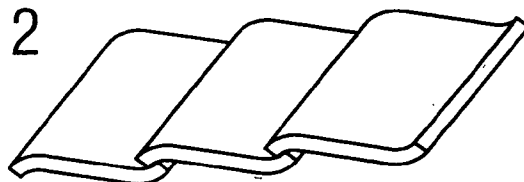

Fig. 12



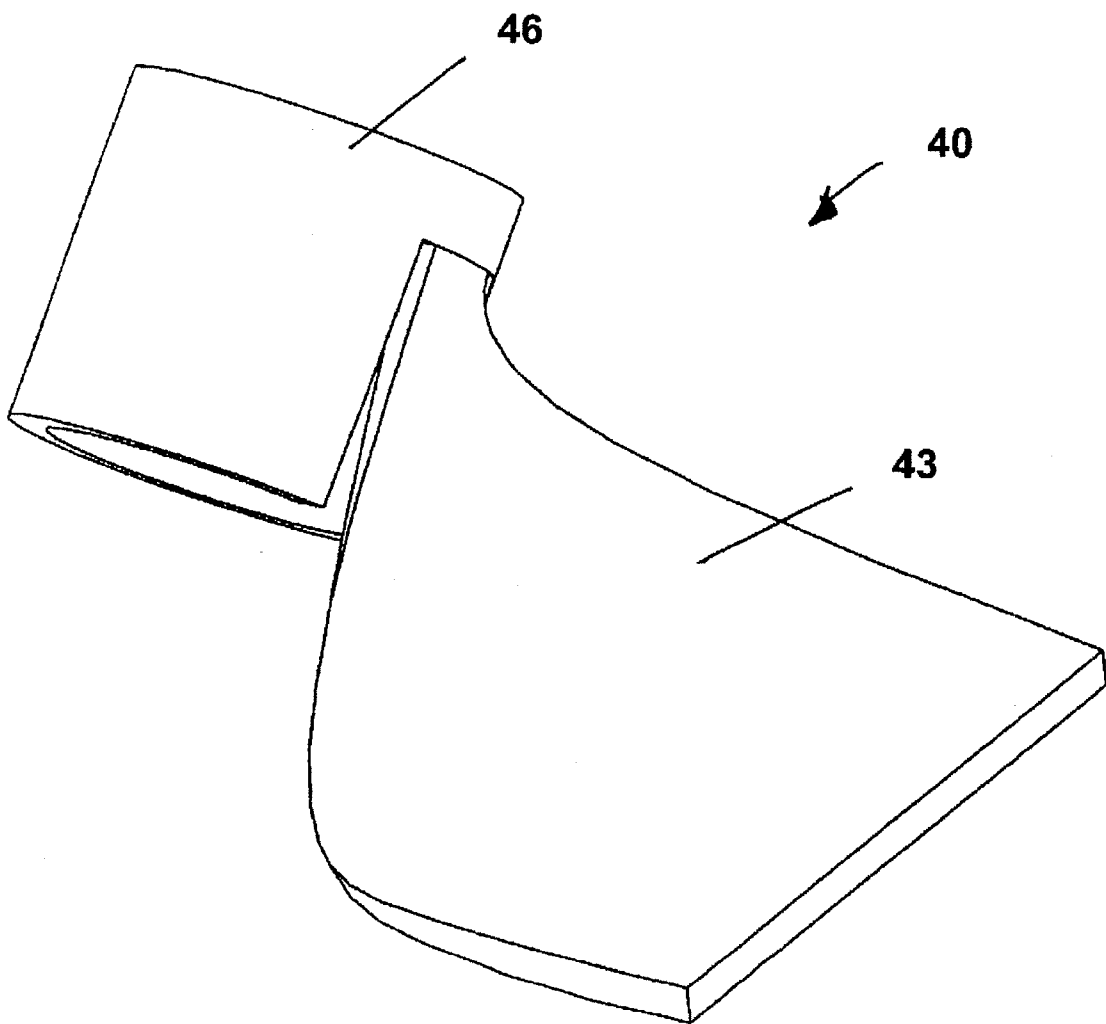

Fig. 13a

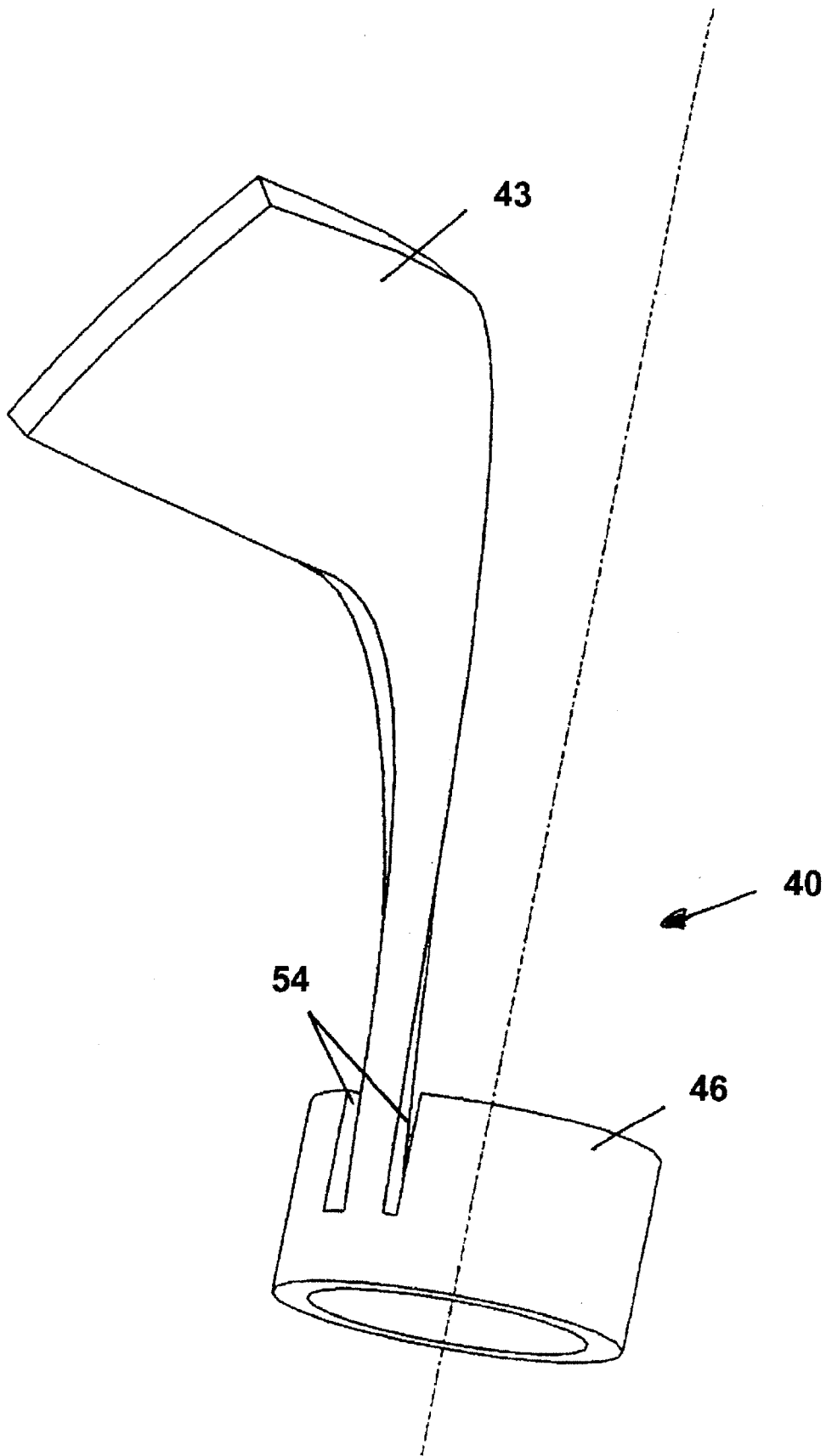

Fig. 13b

Fig. 13C

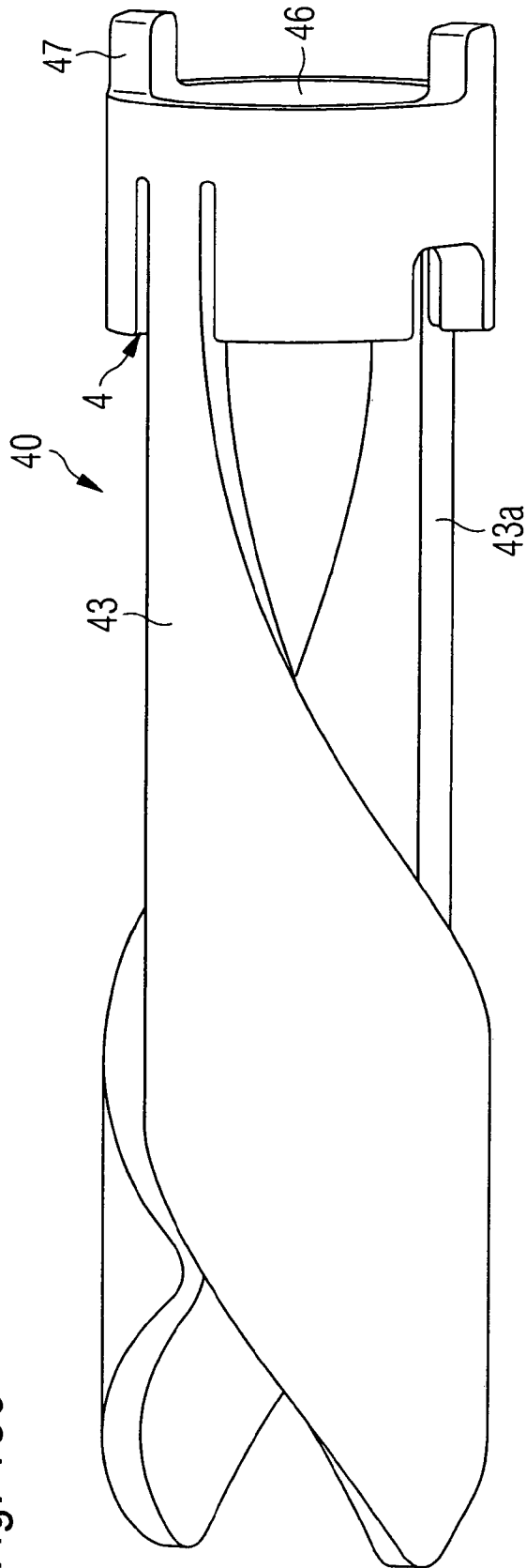

Fig. 13d

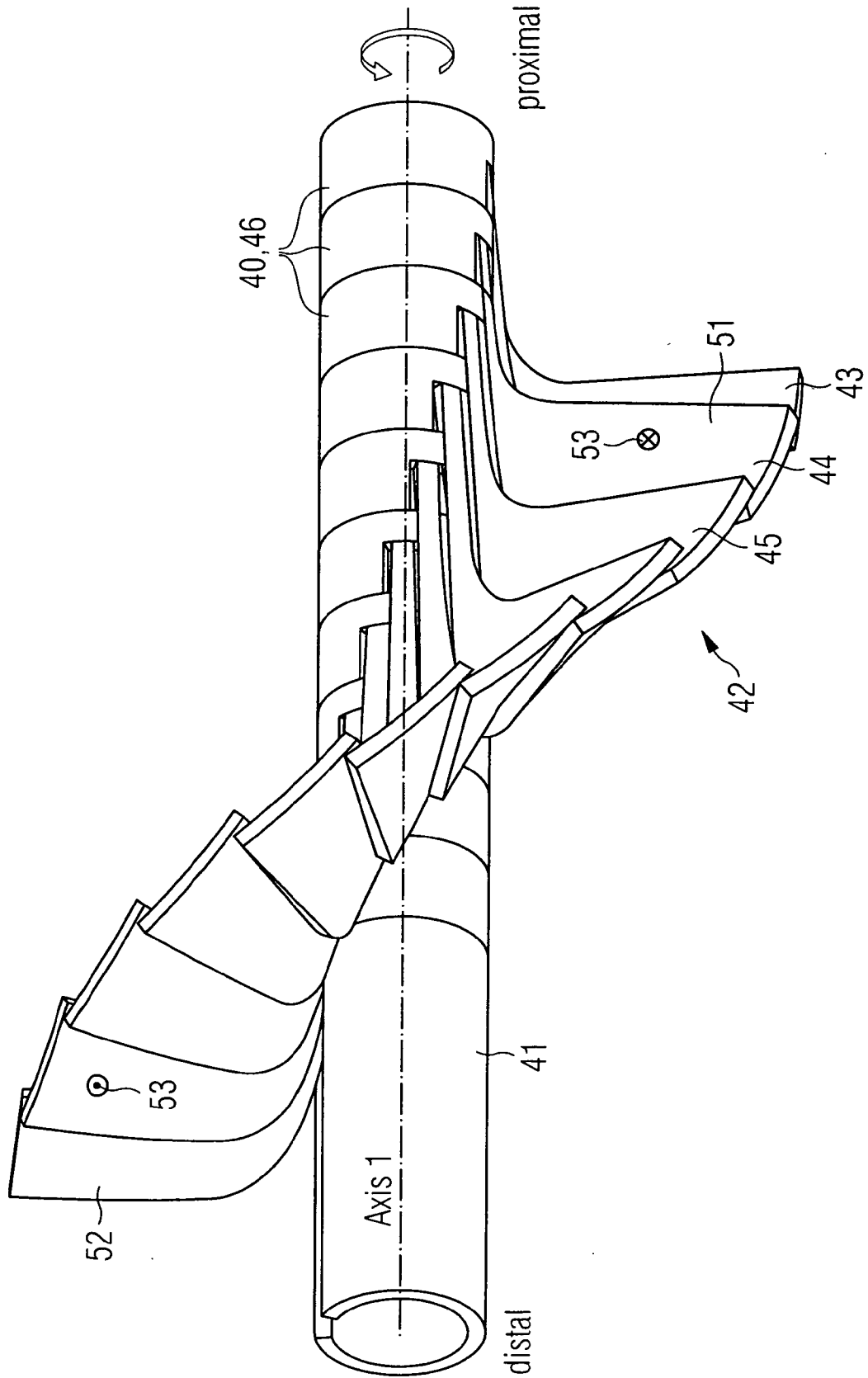

Fig. 13e

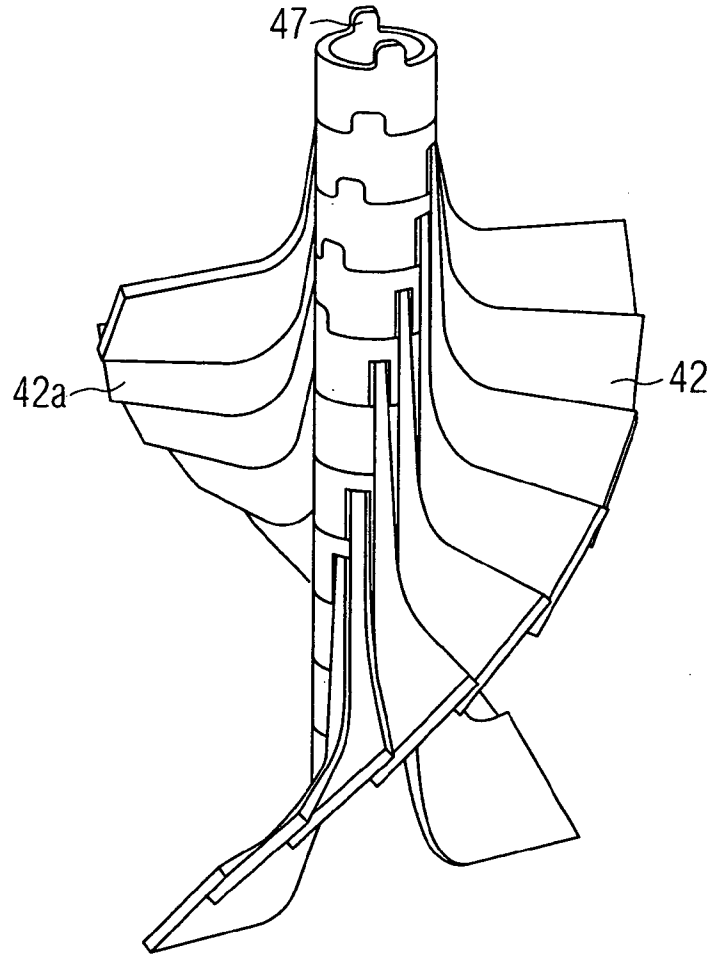

Fig. 13f

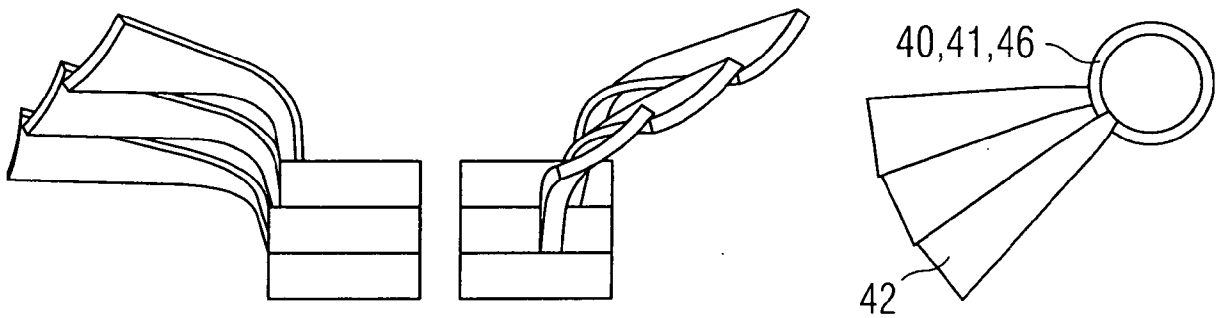

Fig. 13g

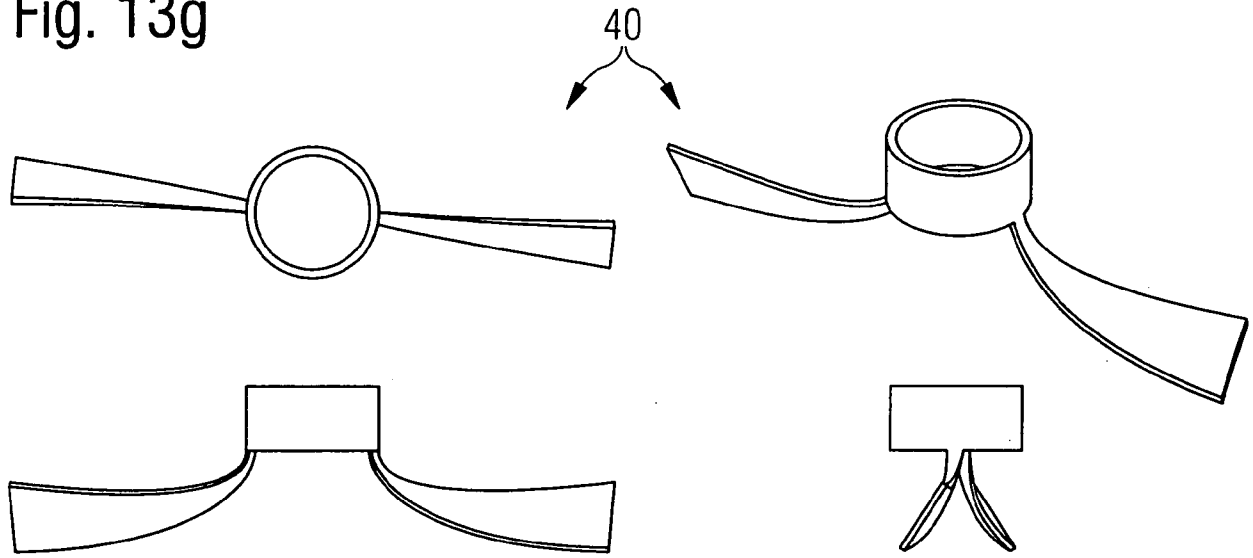

Fig. 13h

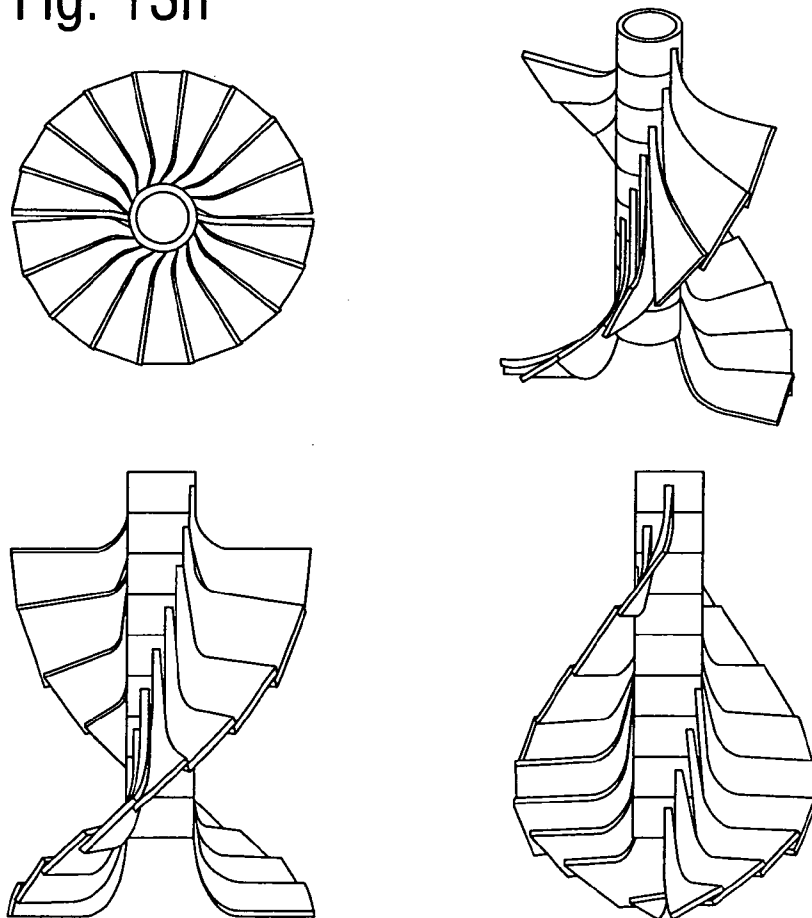

Fig. 13i

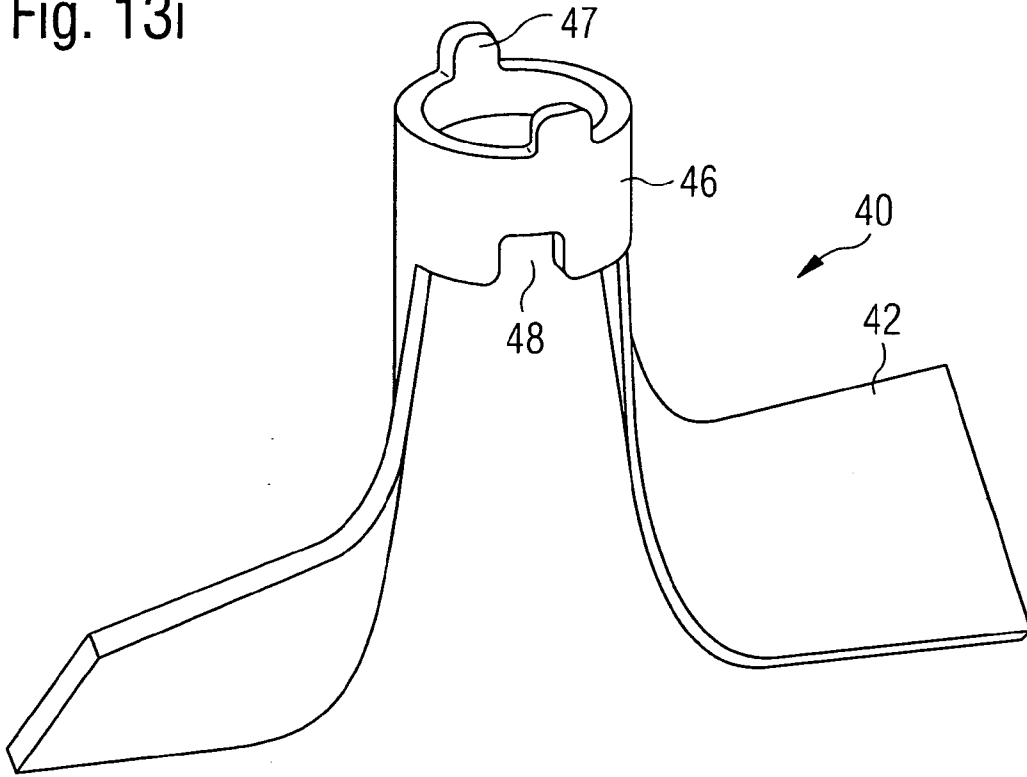
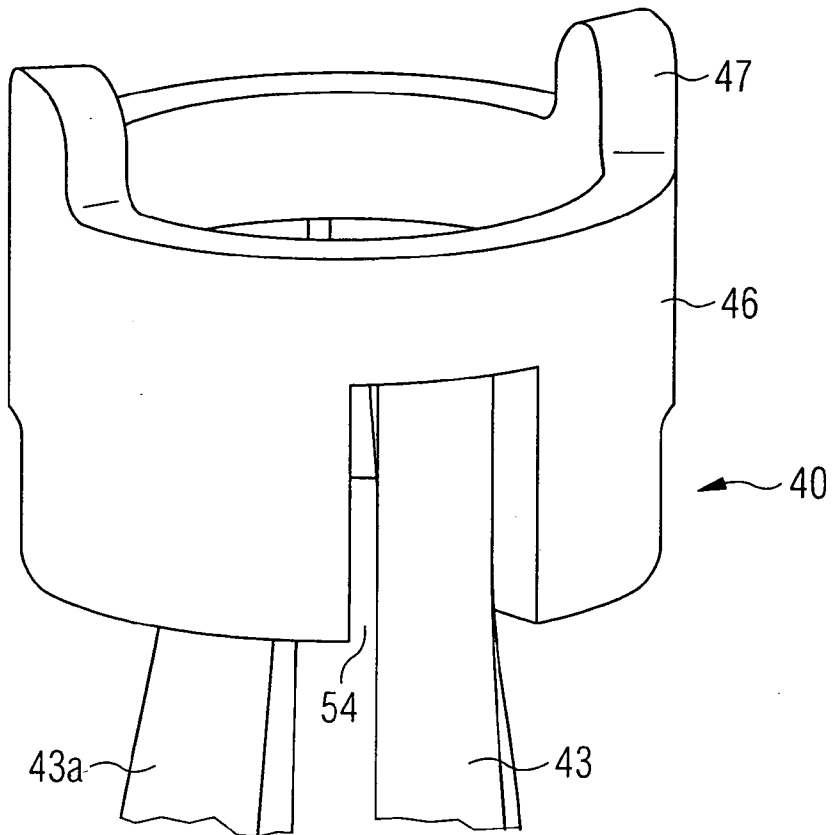

Fig. 13j



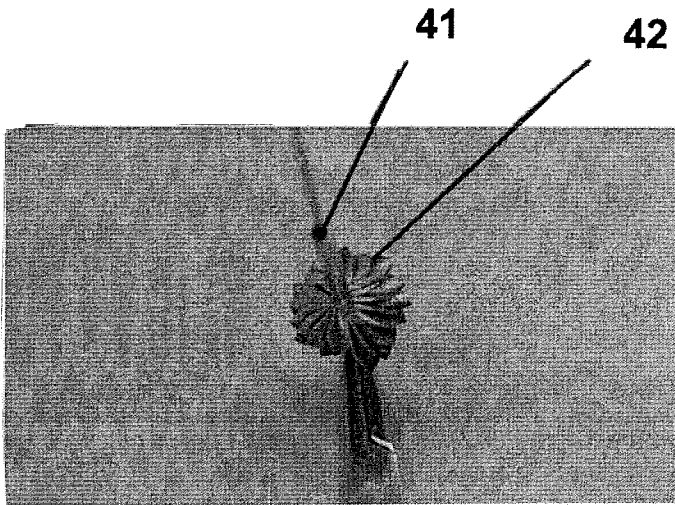

Fig. 13k

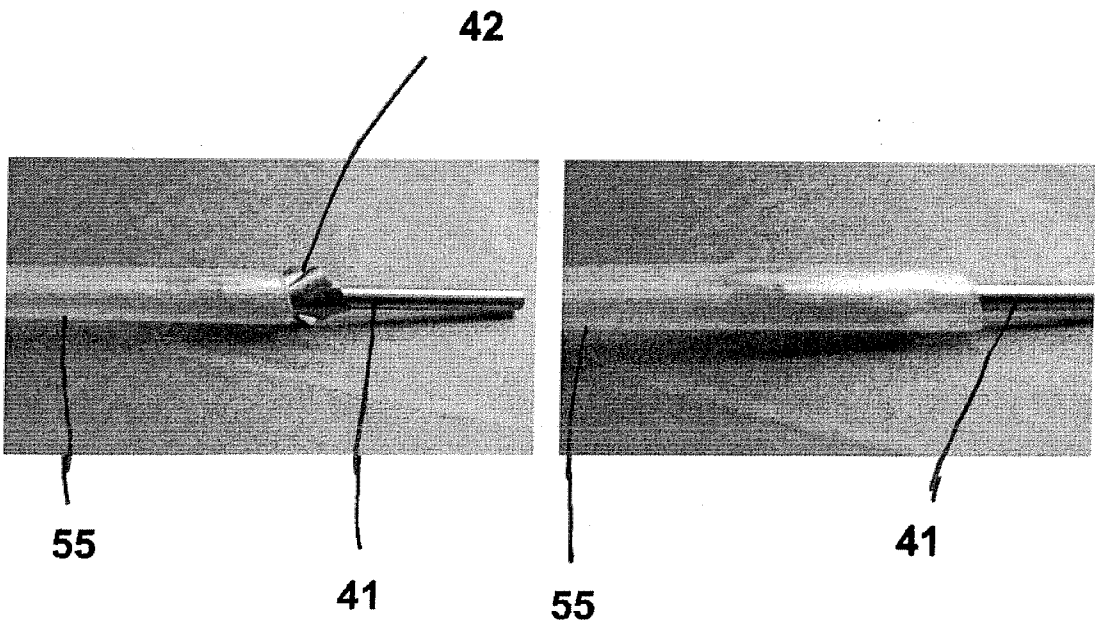
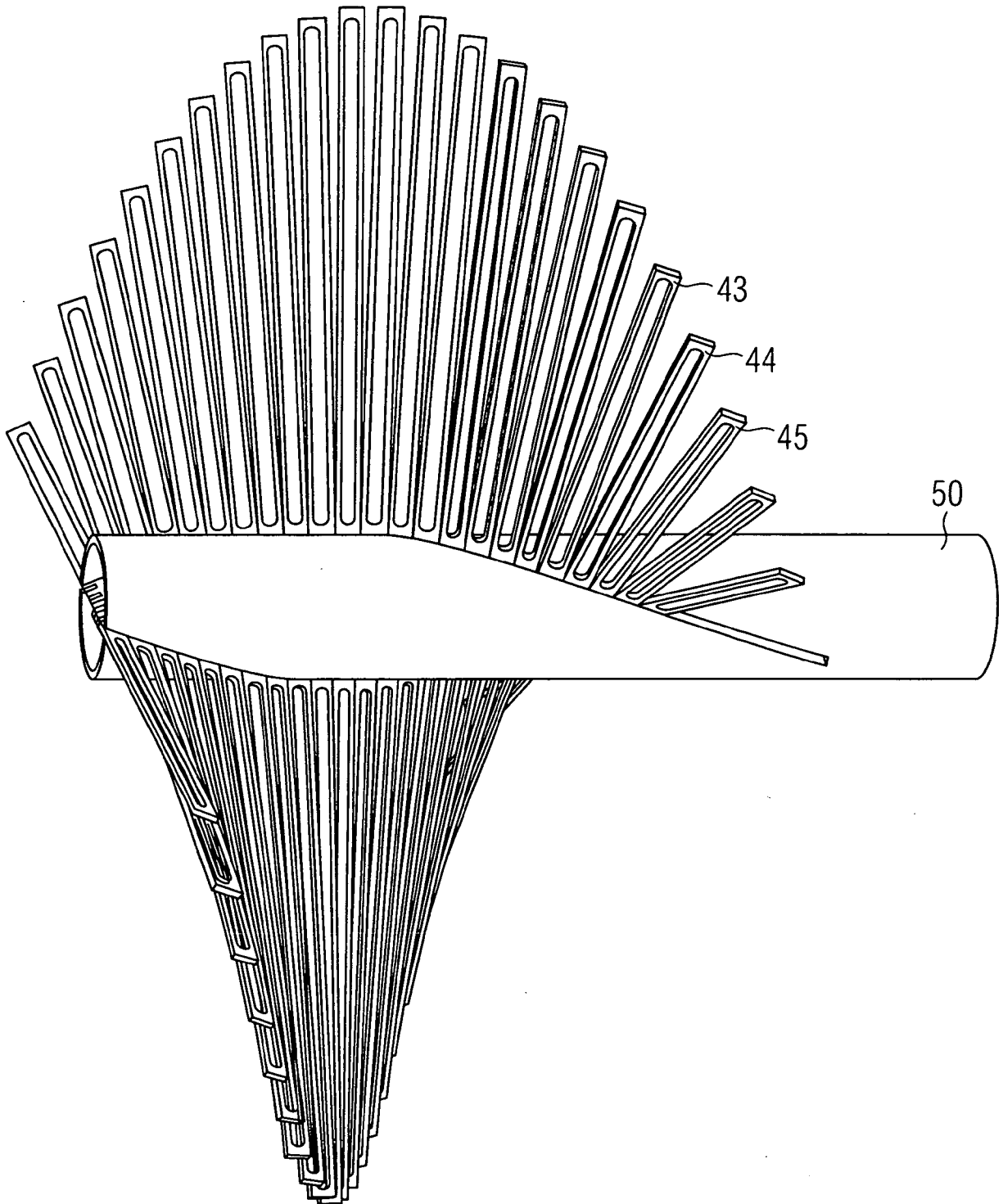

Fig. 13l

Fig. 14a



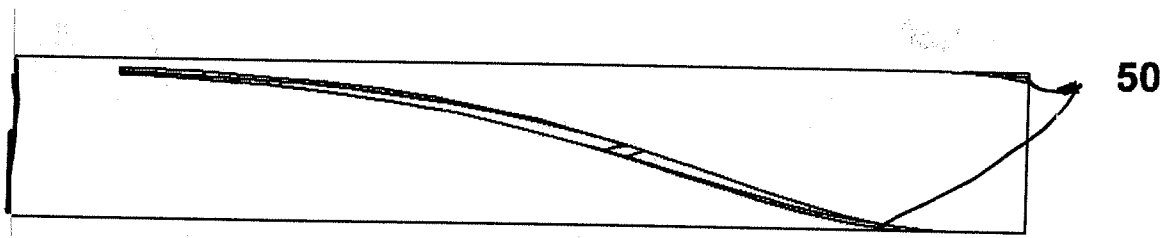

Fig. 14b

Fig. 14c

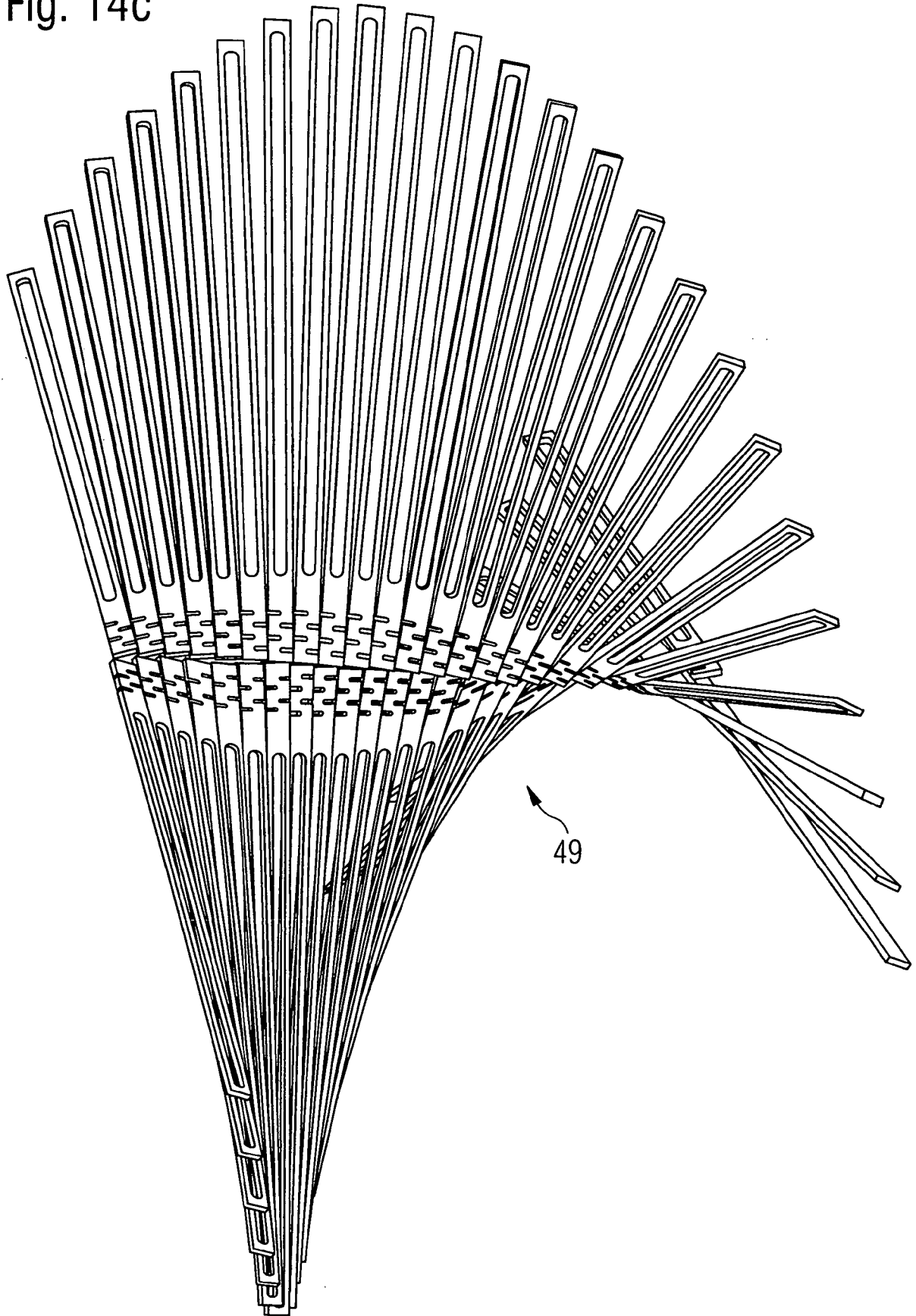

Fig. 14d

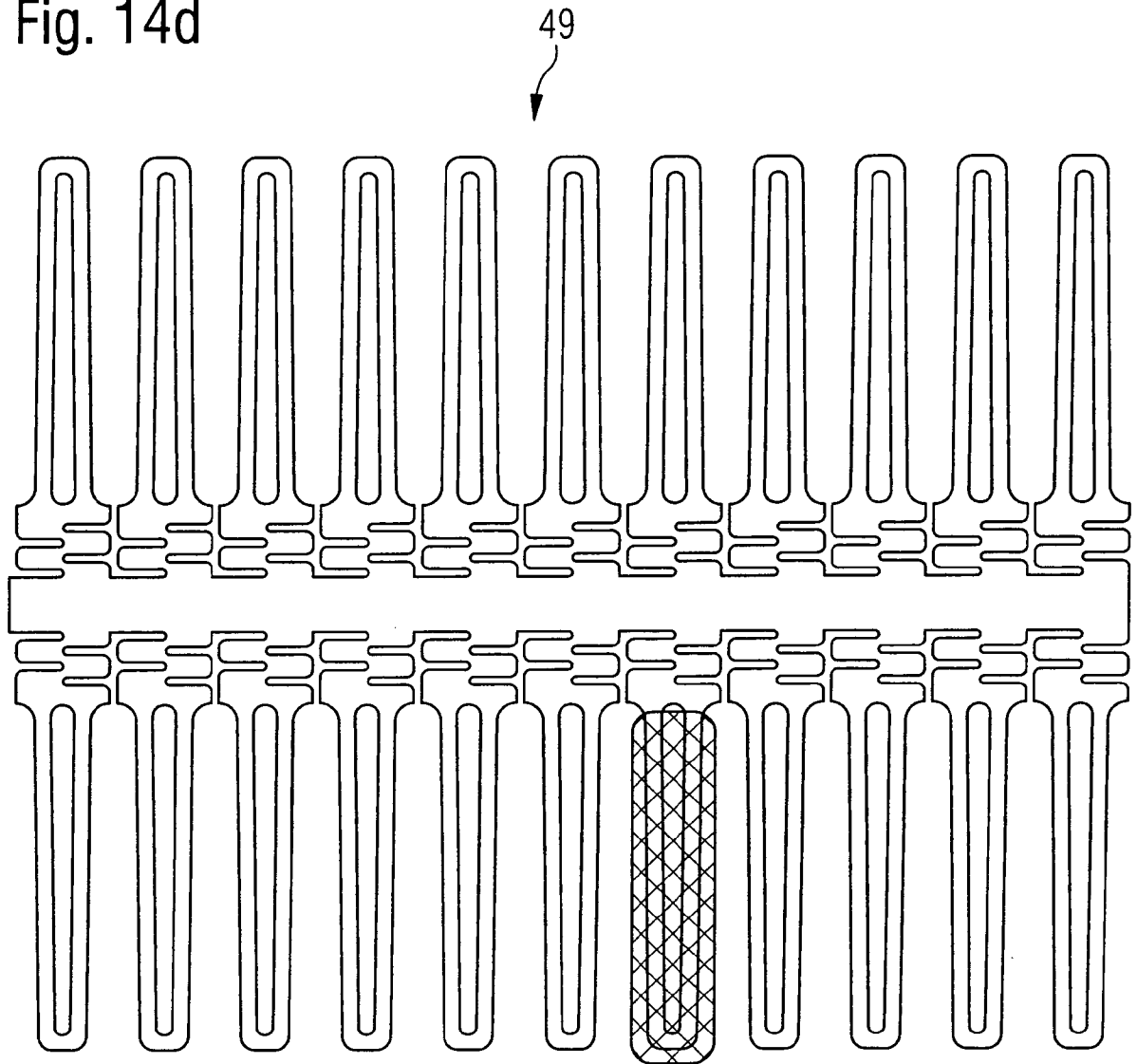

Fig. 15a

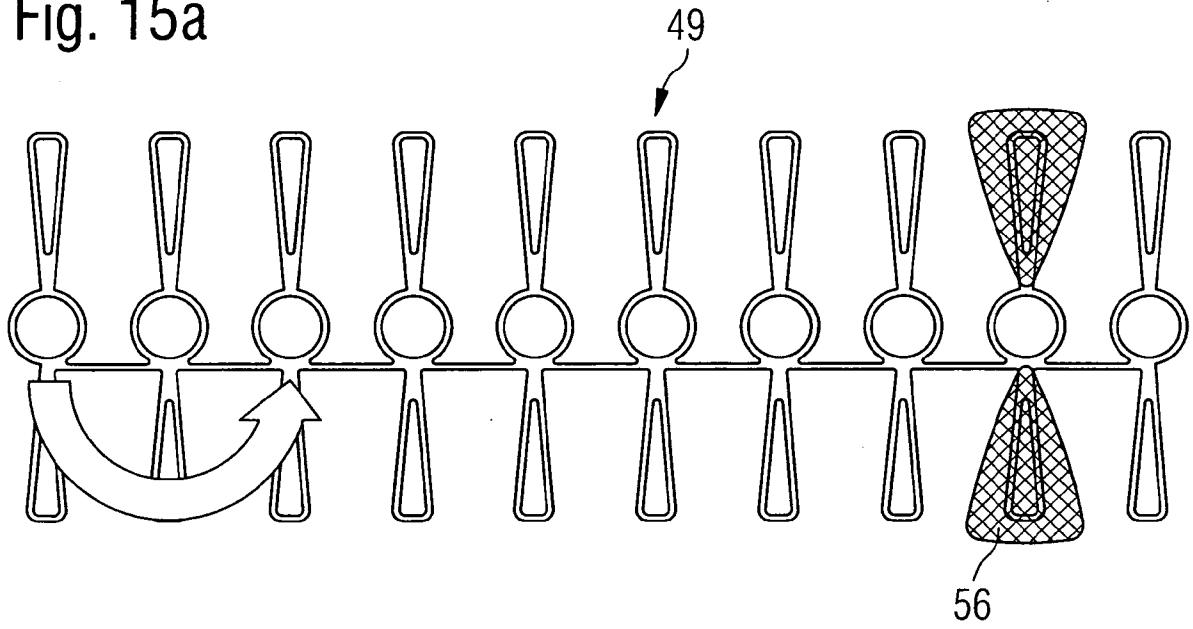
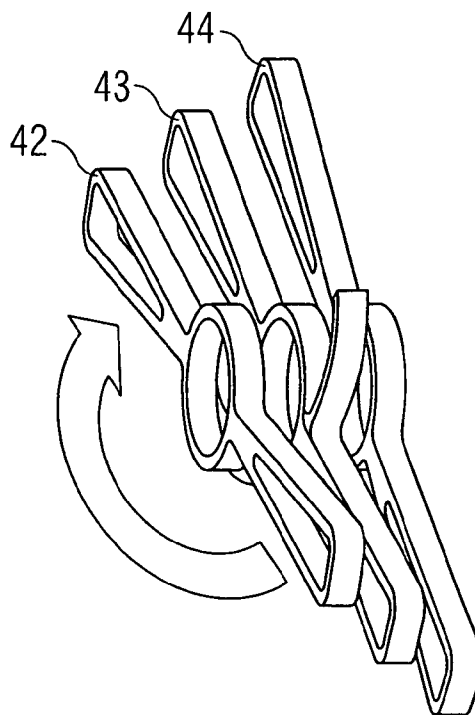

Fig. 15b



INTERNATIONAL SEARCH REPORT

International application No
PCT/EP2010/004023

A. CLASSIFICATION OF SUBJECT MATTER
 INV. A61M1/10 F04D3/00 F04D29/18 F04D29/24
 ADD.

According to International Patent Classification (IPC) or to both national classification and IPC

B. FIELDS SEARCHED
 Minimum documentation searched (classification system followed by classification symbols)
 A61M F04D

Documentation searched other than minimum documentation to the extent that such documents are included in the fields searched

Electronic data base consulted during the international search (name of data base and, where practical, search terms used)
 EPO-Internal, WPI Data

C. DOCUMENTS CONSIDERED TO BE RELEVANT

Category*	Citation of document, with indication, where appropriate, of the relevant passages	Relevant to claim No.
X	WO 2009/029959 A2 (MEDICAL VALUE PARTNERS LLC [US]; SHIFFLETTE J MICHAEL [US]) 5 March 2009 (2009-03-05) claims; figures paragraphs [0024] - [0034], [0063] - [0074], [0078] - [0080]	1-14, 20-26
A	US 7 393 181 B2 (MCBRIDE MARK W [US] ET AL) 1 July 2008 (2008-07-01) cited in the application figures 1-4 column 5, line 57 - column 7, line 23	1
A	WO 94/05347 A1 (REITAN OEYVIND [SE]) 17 March 1994 (1994-03-17) claims; figures page 4, line 31 - page 7, line 7	1
	-/--	

Further documents are listed in the continuation of Box C. See patent family annex.

* Special categories of cited documents :

"A" document defining the general state of the art which is not considered to be of particular relevance	"T" later document published after the international filing date or priority date and not in conflict with the application but cited to understand the principle or theory underlying the invention
"E" earlier document but published on or after the international filing date	"X" document of particular relevance; the claimed invention cannot be considered novel or cannot be considered to involve an inventive step when the document is taken alone
"L" document which may throw doubts on priority claim(s) or which is cited to establish the publication date of another citation or other special reason (as specified)	"Y" document of particular relevance; the claimed invention cannot be considered to involve an inventive step when the document is combined with one or more other such documents, such combination being obvious to a person skilled in the art.
"O" document referring to an oral disclosure, use, exhibition or other means	"&" document member of the same patent family
"P" document published prior to the international filing date but later than the priority date claimed	

Date of the actual completion of the international search 24 September 2010	Date of mailing of the international search report 01/10/2010
--	--

Name and mailing address of the ISA/ European Patent Office, P.B. 5818 Patentlaan 2 NL - 2280 HV Rijswijk Tel. (+31-70) 340-2040, Fax: (+31-70) 340-3016	Authorized officer Kaden, Malte
--	--

INTERNATIONAL SEARCH REPORT

International application No

PCT/EP2010/004023

C(Continuation). DOCUMENTS CONSIDERED TO BE RELEVANT

Category*	Citation of document, with indication, where appropriate, of the relevant passages	Relevant to claim No.
A	WO 2009/073037 A1 (MEDICAL VALUE PARTNERS LLC [US]; SHIFFLETTE J MICHAEL [US]) 11 June 2009 (2009-06-11) claims; figures paragraphs [0030] - [0032], [0084] - [0087] -----	1
A	EP 0 364 293 A2 (KENSEY NASH CORP [US]) 18 April 1990 (1990-04-18) figures column 4, lines 26-44 column 5, lines 17-49 -----	1

INTERNATIONAL SEARCH REPORT

Information on patent family members

International application No

PCT/EP2010/004023

Patent document cited in search report	Publication date	Patent family member(s)	Publication date
WO 2009029959	A2	05-03-2009	NONE
US 7393181	B2	01-07-2008	AU 2005286914 A1 30-03-2006 CN 101278127 A 01-10-2008 EP 1789314 A2 30-05-2007 US 2009060743 A1 05-03-2009 US 2006062672 A1 23-03-2006 WO 2006034158 A2 30-03-2006
WO 9405347	A1	17-03-1994	AT 214294 T 15-03-2002 DE 69331713 D1 18-04-2002 DE 69331713 T2 28-11-2002 DK 768900 T3 08-07-2002 EP 0768900 A1 23-04-1997 ES 2170071 T3 01-08-2002 JP 3278160 B2 30-04-2002 JP 8500512 T 23-01-1996 SE 501215 C2 12-12-1994 SE 9202517 A 03-03-1994 US 5749855 A 12-05-1998
WO 2009073037	A1	11-06-2009	AU 2007362036 A1 11-06-2009
EP 0364293	A2	18-04-1990	CA 2000505 A1 13-04-1990 JP 2203867 A 13-08-1990 US 4919647 A 24-04-1990