

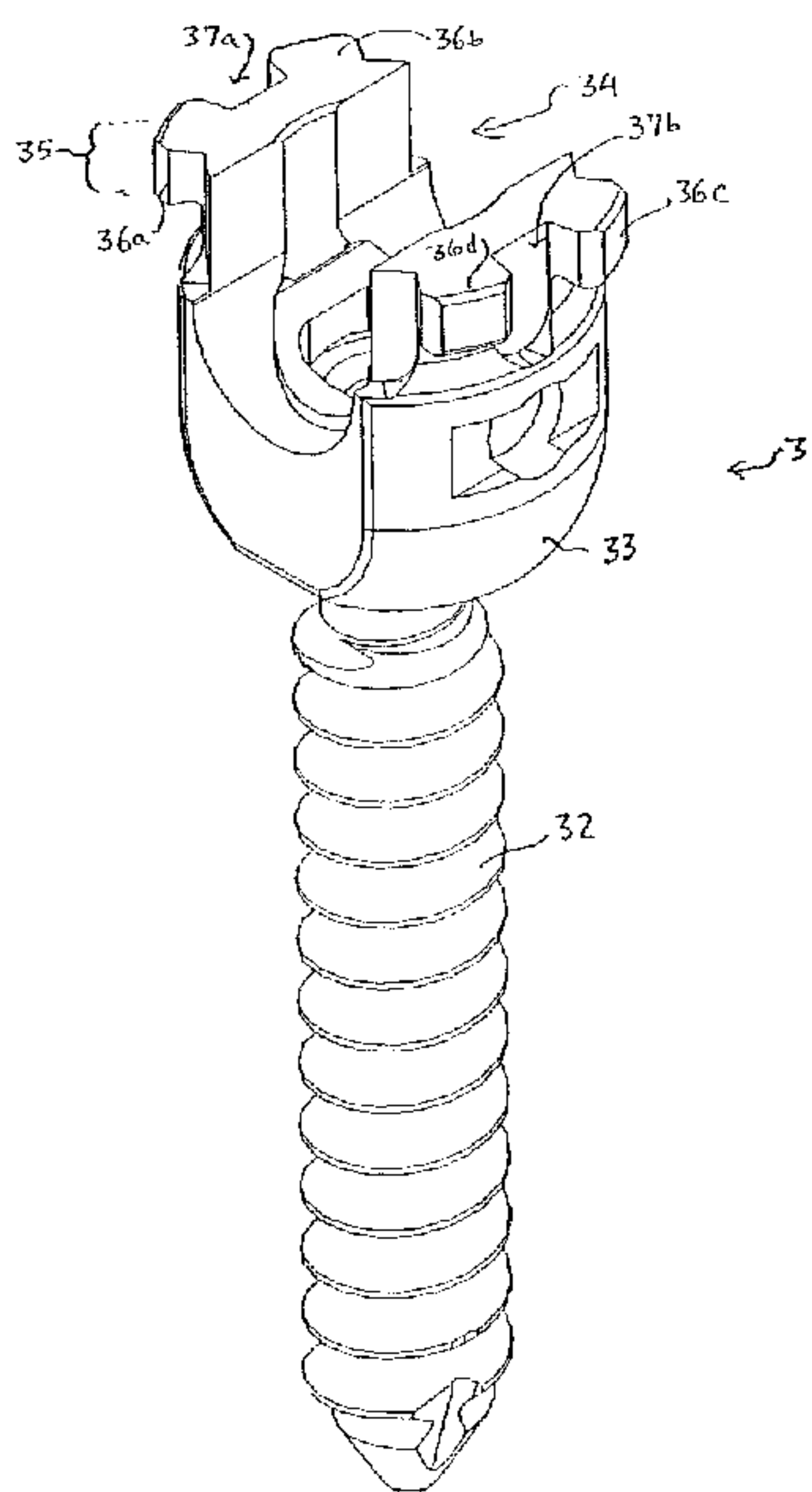

(22) Date de dépôt/Filing Date: 2001/09/20
(41) Mise à la disp. pub./Open to Public Insp.: 2002/03/22
(30) Priorité/Priority: 2000/09/22 (09/667,937) US

(51) Cl.Int.⁷/Int.Cl.⁷ A61B 17/70
(71) Demandeur/Applicant:
DEPUY ACROMED, INC., US
(72) Inventeurs/Inventors:
BURGESS, IAN, US;
SICVOL, CHRISTOPHER WERNER, US;
ROSS, GEORGE JOSEPH, US;
BONO, FRANK SCOTT, US
(74) Agent: OGILVY RENAULT

(54) Titre : DISPOSITIF D'ANCRAGE A CAPUCHON VERROUILLABLE POUR FIXATION ORTHOPEDIQUE
(54) Title: LOCK CAP ANCHOR ASSEMBLY FOR ORTHOPAEDIC FIXATION



(57) **Abrégé/Abstract:**

An assembly such as an anchor screw, bone plate, offset hook, post, transverse connector or other spinal anchor for anchoring to bone and clamping a linkage such as a rod, wire cable or the like. The assembly has a top member with an open slot to receive the linkage, and a twist-lock closure cap to close the open end, capturing the linkage in the slot. One closure cap fits over and around the top member, with a set of segmented protrusions that extend through a corresponding set of protruding flange segments spaced about the circumference of the top member. The cap is configured to rotate and lock against the top member like a flange-locking bayonet mount when turned through a limited degree of rotation. Slots may be provided through the face of the closure cap allowing reduction tabs to project through the cap, and the locking cap may be adapted to a range of screw, eye, hook, post, connector and other anchor assemblies to securely clamp the linkage by use of a rotation tool disposed along an access path aligned with the axis of the screw, thus requiring no lateral clearance along the longitudinal direction of the linkage element. Locking is effected by a set screw that passes through the cap and tightens against the linkage to firmly immobilize it in the anchor assembly. Another cap embodiment fits into the center of the head with a partial twist locking motion. Opposed locking surfaces prevent slippage in the radial direction, and a sloping contact floor surface may apply torque to further increase pressure on urge mating detent features in an adjacent wall.

LOCK CAP ANCHOR ASSEMBLY FOR ORTHOPAEDIC FIXATION

ABSTRACT OF THE DISCLOSURE

An assembly such as an anchor screw, bone plate, offset hook, post, transverse
5 connector or other spinal anchor for anchoring to bone and clamping a linkage such as
a rod, wire cable or the like. The assembly has a top member with an open slot to
receive the linkage, and a twist-lock closure cap to close the open end, capturing the
linkage in the slot. One closure cap fits over and around the top member, with a set of
10 segmented protrusions that extend through a corresponding set of protruding flange
segments spaced about the circumference of the top member. The cap is configured to
rotate and lock against the top member like a flange-locking bayonet mount when
turned through a limited degree of rotation. Slots may be provided through the face of
the closure cap allowing reduction tabs to project through the cap, and the locking cap
15 may be adapted to a range of screw, eye, hook, post, connector and other anchor
assemblies to securely clamp the linkage by use of a rotation tool disposed along an
access path aligned with the axis of the screw, thus requiring no lateral clearance along
the longitudinal direction of the linkage element. Locking is effected by a set screw
that passes through the cap and tightens against the linkage to firmly immobilize it in
20 the anchor assembly. Another cap embodiment fits into the center of the head with a
partial twist locking motion. Opposed locking surfaces prevent slippage in the radial
direction, and a sloping contact floor surface may apply torque to further increase
pressure on urge mating detent features in an adjacent wall.

25

30

LOCK CAP ANCHOR ASSEMBLY FOR ORTHOPAEDIC FIXATION

BACKGROUND

The present invention relates to orthopedic fastening systems and to mechanisms
5 for securing and locking a linking or stabilizing element, such as a rod, to a bone screw
having a slotted head that receives the rod therein. It also relates to structures or
anchor assemblies having such a slotted or open head for receiving a rod, wherein the
slotted portion extends from a hook, plate, bracket or positioning arm.

A number of such structures are known. Thus, for example, the widely used
10 Harms T-plate used for stabilizing the cervical vertebrae has a projecting slotted bolt
adapted to receive a rod or cable through the slot and clamp down by screwing a nut
along the bolt to bear down against the rod. Several patents show holding structures for
a fixation rod that are incorporated in the head of a screw, as in U.S. Patent 5,672,176,
or into a small offset plate which itself may be fastened to the bone, as shown in
15 published International Application WO96/28105. Other systems involve hooks,
transverse rod connectors, or tandem connectors. Various tools have been provided for
these systems to enable the surgeon to bend and shape the rod to a desired contour *in*
situ, to position the rod in the slot of a bolt or head, and to secure the rod in position.

Because the rod is the stabilizing member which provides a precise contour,
20 spacing or connection between one or more vertebrae, bones or bone fragments,
alignment is quite critical, and the ability to pass the rod through two or more
connecting assemblies requires various actions to form and shape the rod, or align the
receiving structures at defined positions or path before final clamping is effected. This
may involve positioning and removing the rod several times to check and adjust the
25 degree of alignment. Thus, it is generally desirable to have a closure or secure locking
mechanism that may be effected with simple installation steps.

One generally accepted locking mechanism simply involves an internally
threaded locking nut that may be tightened down along the axis of the screw or slotted
shaft, using a tool such as a socket wrench. Another commercial device employs a
30 bayonet-mount cap that captures or is captured by the screw head, as in United States
Patents 5,346,493 and 5,257,993. Another system utilizes a cap element with a
dovetail or dovetail channel that slides over the rod to close the top of the slot and

wedge the rod firmly in position. This latter construction involves no rotation of threaded members, but has the disadvantage that a certain amount of unobstructed lateral space along the rod adjacent to the connection point is necessary for the sliding installation of the closure cap. Furthermore, the cap inserts or sliding wedge closures, while they eliminate the need for awkward screwing or rotational motion during installation, cannot be used with some existing reduction screws, translation hooks or other common hardware having lengthy protruding guide members, reduction tabs or the like. Moreover, the wedge/cap closures are a specialized component that may require the user to switch entirely over to a proprietary line of orthopaedic hardware if he is to utilize the full range of hook, tab, plate and screw fixation points that may be required in spinal surgery.

Accordingly, it would be desirable to provide a closure cap for a bone screw or similar anchor assembly to secure a fixation linkage such as a rod or cable.

It would further be desirable to provide a rod-securing closure mechanism for a screw or anchor that installs simply by a partial turn.

It would further be desirable to provide a rod-securing closure mechanism for a screw or anchor that requires minimal lateral clearance along the rod for its installation.

It would further be desirable to provide a rod securing cap or closure mechanism adaptable to diverse reduction screws.

SUMMARY OF THE INVENTION

One or more of these and other desirable traits are achieved in accordance with the present invention by a fixation assembly wherein a closure cap fits over an opening to close a rod-receiving slot of a fixation screw, hook, post or other anchor assembly, and capture the rod therein. A set screw threads through the cap and tightens against the rod to further clamp it in the assembly. In one embodiment, the closure cap extends over and around the head of the rod-receiving assembly, which may, for example include a slotted shaft, post or head, and the cap is adapted to lock together therewith by limited rotation. This may be accomplished in one embodiment construction by arranging the cap to have a set of sector rim protrusions positioned to fit through a corresponding set of protruding bosses or partial flange segments located on the head, and to rotate into opposition therewith for securing the cap onto the top of the fixation

screw. The protrusions or flange segments are angled, along the radial direction, so that they bear against each other and jam when rotated, thus cannot slip out of engagement. The opposed segments tighten and lock the cap against the head when the cap is rotated through a partial turn of about twenty-three degrees of arc, like a
5 flange-locking bayonet mount. The cap may have a rim that extends over the outside of the bolt head to engage external flange segments on the head. In a preferred embodiment, the mating portions may be located internally in the head, with flange segments projecting radially inward from the perimeter, and the cap fitting between segments in the head of the bolt and locking with a twist-in motion to capture a rod in
10 the opening. A hold-down set screw threads through a central opening in the cap and tightens down against the rod to clamp the rod firmly in place. The closing and clamping may each be effected by a driver tool that operates along the axis of the assembly and requires little or no side clearance to rotate either the cap or the set screw. In the case of the external, twist-on cap, the limited degree of rotation allows
15 the cap to also include slots through the cap to accommodate reduction tabs extending upwardly from the underlying screw or anchor member. The quick-twist closure cap assemblies of the invention may be adapted to a wide range of screw, hook, eye, plate, connector and other anchor assemblies for rod, cable and other linking elements.

20 BRIEF DESCRIPTION OF THE DRAWINGS

These and other features of the invention will be understood more fully from the description below of representative embodiments thereof taken in conjunction with illustrative drawings, wherein

Figures 1A-1C schematically illustrate various spinal fixation rod anchor
25 assemblies of the prior art;

Figure 2 shows one embodiment of an anchor screw of the present invention;

Figures 3 and 3A-3C show views of a closure cap utilized with the anchor screw of Figure 2 in accordance with the present invention;

Figure 4 shows a second embodiment of an anchor member and closure cap of
30 the invention;

Figure 4A is a perspective view from below of the cap of Figure 4;

Figure 4B illustrates details of the anchor member of Figure 4;

Figure 5 shows a third embodiment of an anchor member and closure cap of the invention;

Figures 6A, 6B and 6C illustrate the cap and head structure, respectively, of embodiment of Figure 5 in greater detail; and

5 Figures 7A, 7B and 7C illustrate cap, head and assembled structure, respectively, of another internal twist cap embodiment.

DETAILED DESCRIPTION

The invention and its range of embodiments will be better understood following a brief description of prior art, illustrating approaches to one- and two- part anchor assemblies, as well as certain common constructions.

Figures 1A-1C illustrate prior art anchor mechanisms for securing a fixation rod as used in spinal fixation. Figure 1A illustrates an anchor screw, while Figure 1B shows an offset tab having a slotted post for receiving the rod and Figure 1C shows a combined system in which anchor screws secure rod-shaped offset elements that, in turn, each terminate in an end that grips a common fixation rod. In the anchor screw of Figure 1A, a screw 1 with a rounded head 2 carries a slotted top member 3 into which a rod 5 shown in phantom is clamped by screwing down a threaded press ring or set screw 6. The press ring 6 is turned by engagement along its central portion e.g., by an Allen wrench, and has external threads 6a which fit corresponding internal threads 3a of the top member 3. A separate body 7 fills the space between the inner wall of the top 3 and the ball head 2 of the screw 1, so that when the rod is pressed down by the member 6, the screw head is firmly gripped and all parts are rigidly held together. An external nut 8 threads over the outside of the top to further strengthen and lock the assembly.

25 For this prior art anchor member, the screw 1, the press member 6 and the nut 8 may all be installed with a straight tool, such as an Allen wrench or socket wrench, inserted directly along the axis of the screw.

Figure 1B shows another anchor assembly 15 for receiving a fixation rod 5. In this assembly, an offset tab construction having a body 15a that is anchored by a conventional bone screw 10 and including a slotted post (not numbered) for receiving the rod, is closed by a cap nut 17 which carries a pressure member 18 centrally thereon to press down against the rod 5 as the nut is tightened. In each of these two

constructions, the member 6 or 17 for clamping down against the rod 5 installs by rotational movement.

Another prior art anchor assembly is illustrated in Figure 1C. In this article, a slotted body 21 or 22 is carried either on a bone screw (not visible in the Figure) or on a short length of offset rod 22a. In both cases, the slotted body 21 or 22 receives a rod and clamps it tightly. In this assembly the slotted head member 21 or 22 has angled or dovetailed walls at its upper portion, and a correspondingly shaped sliding cap member 23 is pressed along the dovetail into the upper region, sliding along the axis of the slot to close the slot and wedge firmly against the rod passing therethrough. As noted above, this construction has a disadvantage that a lateral clearance along the length of the rod is necessary for movement of the closure member 23 into position. Other constructions are shown in U.S. Patents Nos. 5,346,493, 5,257,993 and elsewhere.

Thus, the art includes both one-piece, and many-piece anchor assemblies, and these may look like screws, or may be specialized elements that are themselves to be anchored by another assembly. As described further below, the present invention provides a closing and fixing mechanism of enhanced utility, with a structure adaptable to much of this broad range of hooks, screws, connector assemblies and other orthopaedic anchor hardware involving one or more rod, cable, wire or other linking elements.

Figure 2 illustrates a first embodiment of an anchor screw assembly 31 of the present invention. As shown, the anchor screw assembly 31 includes a screw 32 and a top member 33 which may be integral with the screw or, like the prior art construction of Figure 1A, may be a separate head member that secures to the proximal end of the screw 32. The top member 33 includes a slot indicated generally by 34 for receiving a rod, and contains at its uppermost region 35, a plurality of segmented or partial flange members 36a, 36b, 36c, 36d which extend radially outward from its perimeter and have respective slots or spaces 37a, 37b therebetween. As further shown in Figure 2, each of the flange segments 36a, 36b..36d has a lower surface 38, as best seen in the end views of flange segments 36a and 36c, that engages a closure cap 40 (Figures 3A-3C). While not shown, one or more of the flange segments or cap may include a notch, detent or catch or a jamming feature, to prevent rotation in the opposite sense.

The anchor screw or hook 31 of Figure 2 is used in conjunction with a closure cap 40 which is shown in an upward-facing view, from below, in Figure 3C. The cap 40 fits over and around the upper portion 35 of the slotted, rod receiving top member. As shown Figure 3, the cap 40 includes a body 41 having a central threaded bore 42 extending therethrough and a pair of dependent side members 43a, 43b on opposed peripheral sides thereof which extend downward on opposed sides surrounding the outer circumference of the top member 33. Each of the side members 43a, 43b carries mating inwardly directed protrusions 46a, 46b, and 46c, 46d, respectively, which are spaced apart and positioned to correspond to the segmented flange members 36a-36d of the screw head. In particular, the protrusions 46a to 46d are positioned below the main body of the cap 41 by an amount corresponding to the maximum thickness of the flange segments 36a to 36d, and are rotationally offset so as to pass down through the gaps between segments and rotate into gripping engagement around the segments by a partial rotation of the cap 40 about the screw head assembly or top member 33, in the manner of a bayonet mounted lid closure. This secures the cap 40 on the top member closing the slot to prevent movement of the rod or cable from the head along the axial direction of the screw 32. A set screw (not shown) threaded through the aperture 42 is then tightened to clamp firmly down against the rod, cable or other linkage captured in the slot 34 (Figure 2).

Advantageously, with the foregoing construction, the anchor screw 31 and the closure assembly 40 as well as the set screw (not illustrated) all install by simple rotational movement of a tool that extends directly along the axis of the screw. Moreover, as illustrated, the initial locking of the cap on the head assembly is effected by a small rotational movement, substantially less than one-half turn, which corresponds approximately to the length of the lower surface 38 of one flange segment, or about 20° of rotational movement. Thus a very slight movement is sufficient to capture the rod 5 (Figures 1A-1C) within the slot 34 during initial setup or fitting of the fixation rod.

This twist-lock flanged anchoring assembly with a cap structure of the present invention is readily adapted to diverse other fixation screws of known design, and thus in various alternative embodiments and adaptations may carry forward the advantages of those other designs. Thus, for example, the locking cap assembly of Figures 2-3 of

the invention may be adapted to an anchor assembly such as a reduction screw, anchor screw, or hook in which the anchor member possesses protruding reduction tabs that extend upwardly from the head of the anchoring assembly.

Such an embodiment 50 is shown in Figure 4. In this embodiment, the head 53
5 of the anchor assembly has a pair of reduction tabs 55 extending upwardly from the sides of the slot. In this case, the invention contemplates a closure cap 60 with a rim-engaging securing structure similar to that of cap 40 for engagement by a small rotational motion, but the cap structure further includes a pair of arcuate slots 62a, 62b located in its central region and sized for passage of the reduction tabs 55 or other
10 protruding head structure therethrough. Each of the slots 62a, 62b extends past the edges of the tabs 55, permitting sufficient rotation of the cap to lock the cap in position. The structure of the cap itself strengthens or supports both the surrounding wall of the rod receiving slot, and the thin-walled tabs 55 which rise therefrom, while leaving the central on-axis region above the cap entirely unobstructed for insertion, for example, of
15 a set screw along an axial direction, and permitting line-of-sight access by a driver for installation.

In any of the foregoing constructions, the rod-receiving head assembly or top member 33, 53 may be integral with the anchor screw 35, 52 or may be constituted by a separate slotted head member that fits about the top of the screw to grip the rod or
20 other connecting linkage. Thus, the invention applies to diverse anchors, hooks, monoaxial screws, transverse connections or tandem connections, slotted connectors or the like.

Figure 4 illustrates this aspect of the invention for a reduction tab embodiment of which the head is separate from the screw. As shown, the anchor screw assembly 50
25 has a screw body 52 with an enlarged head 54 which may, for example, have an Allen or other female socket formed therein (not shown) for applying torque along the axis of the screw to insert the screw in bone. A slotted top member 53 having a tapered interior bore is first fitted over the head 54, receiving the screw body from above, capturing the enlarged ball head 54 of the screw therein. A compressed member (not
30 shown) which may be similar to element 7 of Figure 1A, may be provided to create a binding fit, and this element may be fixed in place, for example, by swaging at opposed surface relief drillings 53a, or it may fit by simple compression. The provision of top

member 53 as a separate head structure that is loosely fixed to, but originally decoupled from, the screw 52 in this manner allows the slot angle to be set at a later stage of installation, while avoiding the risk of losing separate small components.

The cap 60 of this embodiment, which is shown in a perspective view from
5 below in Figure 4A, is similar to that of the first described embodiment, but includes arcuate slots 62a, 62b to accommodate the projecting reduction tabs. In each case, the cap member having a dependent locking rim that grips the outside of the slotted top and closes the slot by a partial rotation, provides a simple and unobstructed procedure for closing the head of the anchor and capturing the rod, cable or other linkage in the
10 anchor assembly and clamping the linkage while fixing the orientation.

In each of the foregoing illustrated embodiments, the cap extends radially beyond the outer radius of the anchor screw head assembly, and has a rim that extends to a greater diameter, and slides between the segmented flange bosses 36 to rotate into a captured position which closes the slot and captures the rod or other linkage within
15 the head of the anchor assembly. A radial slant "RS" may be provided on one or more faces of the opposed locking members as shown in the detail Figure 4B to assure that they cannot slip radially outward under pressure.

In further embodiments, the invention contemplates a twist-on cap member which fits within the head of the anchor assembly rather than extending over and
20 locking on the outside of the head.

Figure 5 illustrates one embodiment 100 of such a twist-in anchor closing mechanism. As shown, the anchor assembly 100 has a screw portion 152 for anchoring in bone, and a head portion 153 for receiving the rod, cable or other linkage. A closure cap 140 closes the slotted end of head 153. As in the previously described
25 embodiments, the screw and head may be separate assemblies, in which case the upper portion of the screw preferably has a ball end as described above that allows the head to pivot about the axis of the screw and achieve a further degree of freedom in angular orientation before clamping down. As with the earlier described embodiments, the cap or closure portion 140 may have a central bore 145 which is internally threaded to
30 accommodate a set screw to further clamp the rod in the slot; however, to simplify the drawing, threads are omitted from Figure 5.

The internal closure cap 140 has a plurality of radially protruding flange segments 146, of which one is visible in the Figure, and the cap is pushed downwardly on the head so the respective inward and outward directed segments pass between each other, in a manner similar to the above-described embodiments. Thus, the segments
5 146 fit between corresponding, inwardly protruding segments 158 of the head 153 and lock thereagainst by a small rotation of the cap 140.

Figures 6A and 6B illustrate the structure of the twist-in cap 140 and the slotted head 153 in greater detail.

Figure 6A shows the closure cap 140, and Figure 6B shows the head assembly
10 153, of an internal closure locking cap of Figure 5. As shown, the head assembly 153 of the anchor screw has a plurality of internally projecting bosses 158 and the closure cap 140 has corresponding outwardly projecting bosses 146. Respective bosses 146, 158 are dimensioned such that the cap 140 may be pushed downwardly between spaces of corresponding bosses to position the upper surface 149 of the cap bosses below the
15 lower surface 159 of the retaining head bosses 158. As shown in Figure 6A and 6B, these mating contact surfaces are angled or sloped downwardly toward the center so that when the cap 140 is rotated to place opposed bosses in an engagement with each other, the cap exerts a net inwardly directed force on the head to prevent spreading of the retaining slot. The contours of the sloped ends are relatively sharply defined,
20 effectively forming a circumferential ridge 149a, 159a and groove 149b, 159b on each of the respective components (Figure 6C). The ridge of one part fits in the groove of the other, so that the closure is centered and grips over a substantial contact area.

As best seen in Figures 5 and 6A, the twist-in cap has opposed edge flats 144 which may provide a contact or engagement surface for a tool such as a wrench used
25 for turning the cap upon installation. Each of the flats 144 has a corner to prevent over-rotation of the cap, so that upon insertion it rotates to exactly position the respective bosses 146, 158 opposite each other as the anchor assembly is closed. The set screw is then tightened to secure the fixation linkage captured in the slot.

Figures 7A-7C illustrate another embodiment of a twist-in closure cap and spinal
30 anchor assembly, having an anchor screw, a slotted head and a twist-in closure cap. As in the previously described embodiments, the screw and head may be separate assemblies, e.g., to achieve freedom in angular orientation before clamping down. The

head and cap structure similarly may be adapted to spinal anchor assemblies of other types, such as transverse connectors, anchor plates and other link-receiving hardware. As with the earlier described embodiments, the cap may have a central bore which is internally threaded to accommodate a clamping set screw to lock and immobilize the linkage once it has been captured in the slot; however, to simplify the drawing, threads are omitted from Figures 7A and 7C.

In this embodiment, the radially protruding bosses or flange segments 146 of the cap, and the inwardly protruding bosses 158 of the head are arranged so the respective inward and outward directed segments pass between each other, when the cap is pushed downwardly into the head, in a manner similar to the above-described embodiments. Thus, the segments 146 fit between corresponding, inwardly protruding segments 158 of the head and lock thereagainst by a small rotation of the cap. In addition, the twist-lock mechanism may be configured to exert enhanced contact force in a detent region when the clamp screw is tightened down.

As shown in Figures 7A-C, this is achieved in a presently preferred embodiment by providing lower and upper contact faces 159, 149 on the segments 158, 146 of the head and cap, respectively, that slope downward toward the center so that when the set screw is tightened the upward force on the cap draws the segments 158 inward and upward. A vertically-oriented protruding ridge 158a and mating groove 146a are formed on the head and cap, on or directly above the corresponding flange region of each, so that the ridge 158a on the head is urged inwardly against the groove surface of the cap. This effectively locks the rotational detent to prevent any rotational movement of the cap once the set screw is tightened.

As further seen in Figures 7A and 7C, the twist-in cap has a protruding stop face 164 that contacts the head and prevents over-rotation of the cap when it is turned to close the head. Thus, upon insertion the cap rotates (clockwise as shown) to position the bosses 146, 158 exactly opposite each other as the anchor assembly is closed. The set screw is then tightened to secure the fixation linkage captured in the slot.

30

The invention being thus disclosed and illustrative embodiments depicted herein, further variations and modifications of the invention will occur to those skilled in the art. All such variations and modifications are considered to be within the scope of the invention, as defined by the claims appended hereto and equivalents thereof.

CLAIMS

1. An anchor assembly for securing a fixation rod, such assembly comprising
a spinal anchor assembly having a screw axis and a head member with a slot and
5 an open distal end adapted for passage of a linking element such as a rod or cable
therethrough and a cap for closing the open end
wherein the head member comprises an upwardly extending body having at least
a partial flange portion extending about a perimeter of said head member, and
wherein the cap includes a cover having a plurality of spaced apart radially
10 extending rim protrusions adapted for passing through the partial flange portion when
the cover is moved along the screw axis and rotating into engagement with the partial
flange portion of the head member so as to close the open end and thereby capture the
linking member in the slot,
said cap further having a centrally-placed clamping member for tightening down
15 to further clamp the captured linking member.
2. The assembly of claim 1, wherein the head member includes a pair of reduction
tabs extending upwardly therefrom, and said cap includes a corresponding pair of
circumferentially oriented slots configured for passage of the reduction tabs
20 therethrough so as to allow relative rotation of the head member and the cap.
3. The assembly of claim 1, wherein the clamping member is a clamping screw
that passes centrally through the cap for locking the linking member in position.
- 25 4. The assembly of claim 2, wherein the clamping member includes a clamping
screw that passes centrally through the cap for locking the linking member in position.
5. The assembly of claim 1, wherein the partial flange portion of the head member
extends externally of the perimeter, and said cap rim protrusions project inwardly from
30 a dependent circumferential body.

6. The assembly of claim 1, wherein the partial flange portion of the head member extends internally of the perimeter, and said cap fits within the head member.

7. An anchor assembly for securing a linkage such as a rod or cable, wherein the anchor assembly comprises

an anchor element configured for attachment to a bone, and having a protruding top member including an open slot for passing the linkage therethrough, and

a cap for closing the open slot of the top member

wherein the top member and the cap are adapted to twist-lock together by a partial rotation to cover the slot so as to capture the linkage, and the cap further includes a clamping member for tightening down to secure the linkage.

8. The anchor assembly of claim 7, wherein the top member and cap twist-lock together by engagement of respective flange segments on said top member and said cap.

9. The anchor assembly of claim 8, wherein at least some of the flange segments are sloped along a radial direction.

10. The anchor assembly of claim 7, wherein the clamping member includes a locking bolt threaded in the cap.

11. The anchor assembly of claim 7, wherein the top member includes a surface forming a circumferential ridge for centering the cap.

12. The anchor assembly of claim 7, wherein the top member includes reduction tabs, and the cap includes slots for passage of the reduction tabs therethrough and sized to permit said partial rotation of the cap relative to the top member.

13. The anchor assembly of claim 7, wherein the top member includes radially inwardly protruding capture protrusions, and the cap is a twist-in cap.

14. The anchor assembly of claim 7, wherein the anchor element is an element selected from the group of elements consisting of monoaxial screws, polyaxial screws, hooks, transverse connectors, offset connectors, slotted connectors, wire or cable anchors, and anchors for the connection of multiple longitudinal members.

5

15. A spinal anchor assembly for securing a linking element such as a fixation rod or cable, wherein the anchor assembly includes a head with an open slot for receiving the linking element, the head being adapted to anchor to bone, and said assembly further includes a cap for closing the head to capture the linking element in the slot, said head and said cap each having respective sets of radially-protruding segments positioned such that the respective sets pass between each other as the cap is moved along an axis of the anchor assembly, and lock against each other as the cap is rotated about said axis through a partial rotation.

10

16. The anchor assembly of claim 15, wherein said radially-protruding segments have a radially sloping lower surface to prevent disengagement.

15

17. The anchor assembly of claim 15, wherein said cap is an internal twist-in cap.

20

18. The anchor assembly of claim 15, wherein said cap extends radially outside the head.

19. A method of securing an elongated linking element such as a rod, wire or cable, such method comprising the steps of
providing an anchor assembly configured for fastening to a bone
providing a top structure carried by the anchor assembly and including an open end configured for passage of the linking element through the open end,
providing a cap adapted to close the open end and capture the linking element therein by a partial rotation with respect to the top structure, and
providing an adjustable clamp attached to the cap for clamping the captured linking element.

25

30

20. The method of claim 19, wherein the step of providing a top structure includes providing a top structure with reduction tabs, and wherein the cap is configured with arcuate slots for rotation while said reduction tabs pass through the cap.
- 5 21. The method of claim 19, where the step of providing an anchor assembly includes providing a bone screw, and said top structure is a separate component fitted over the bone screw.

2/10

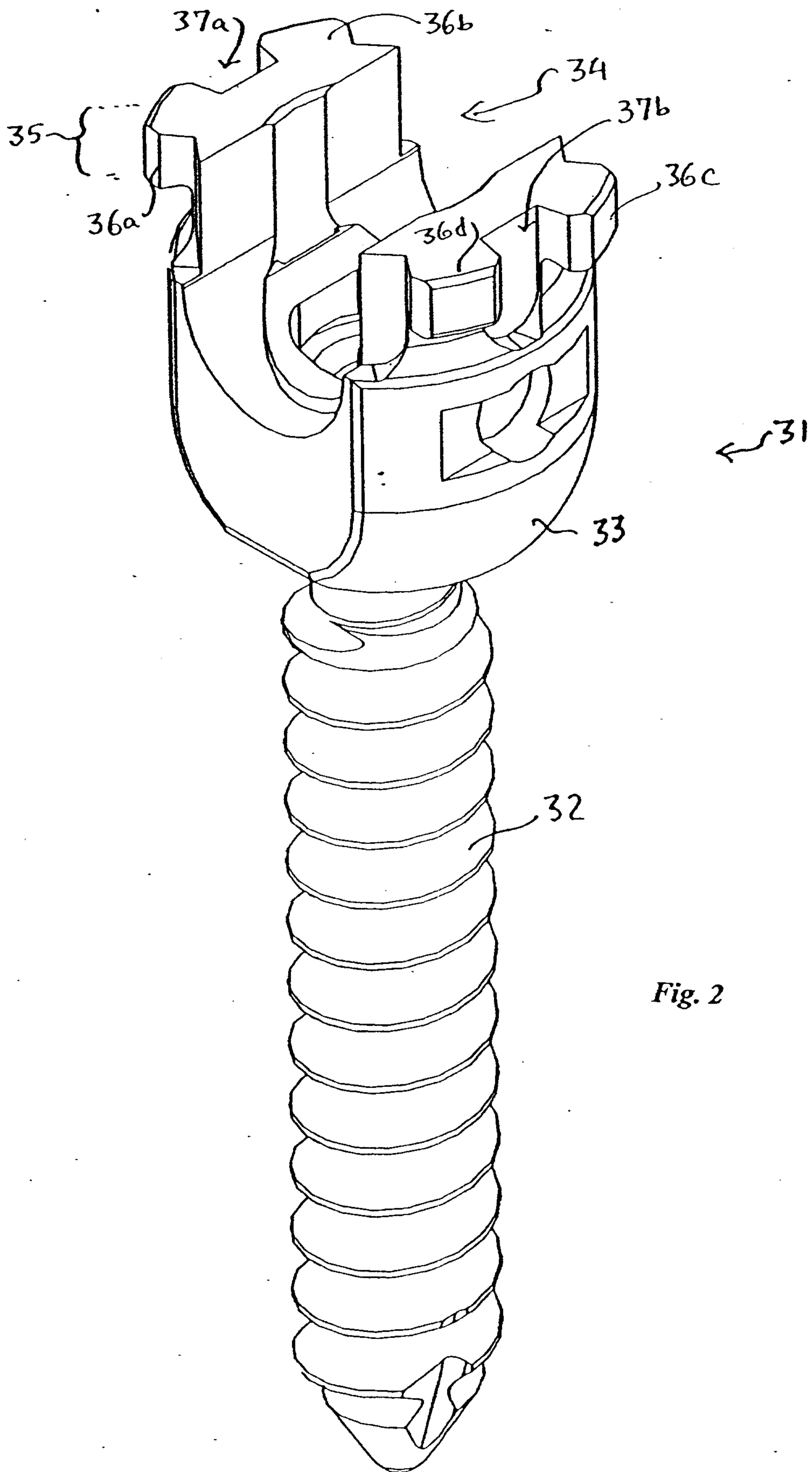

Fig. 2

3/10

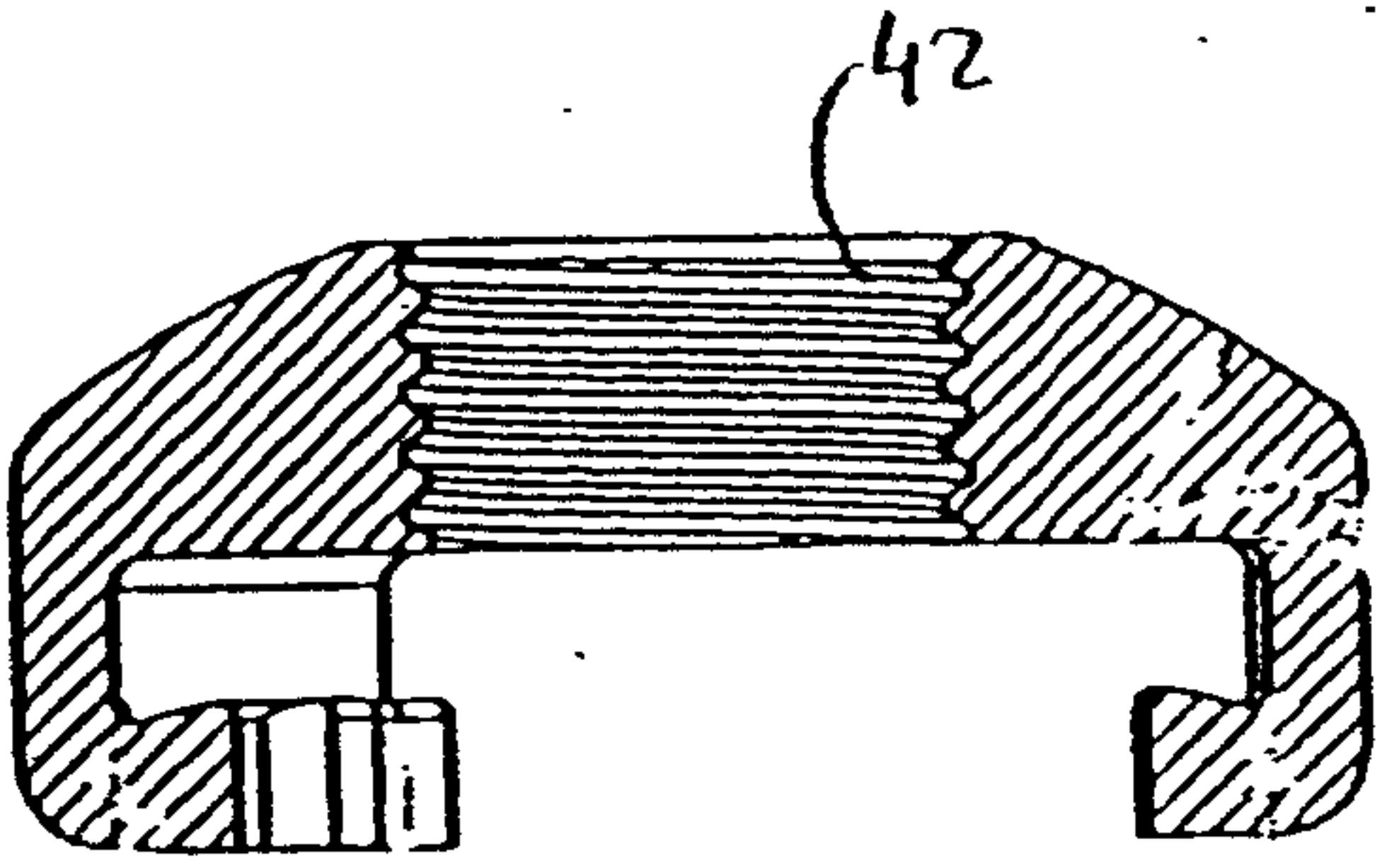

Fig. 3A

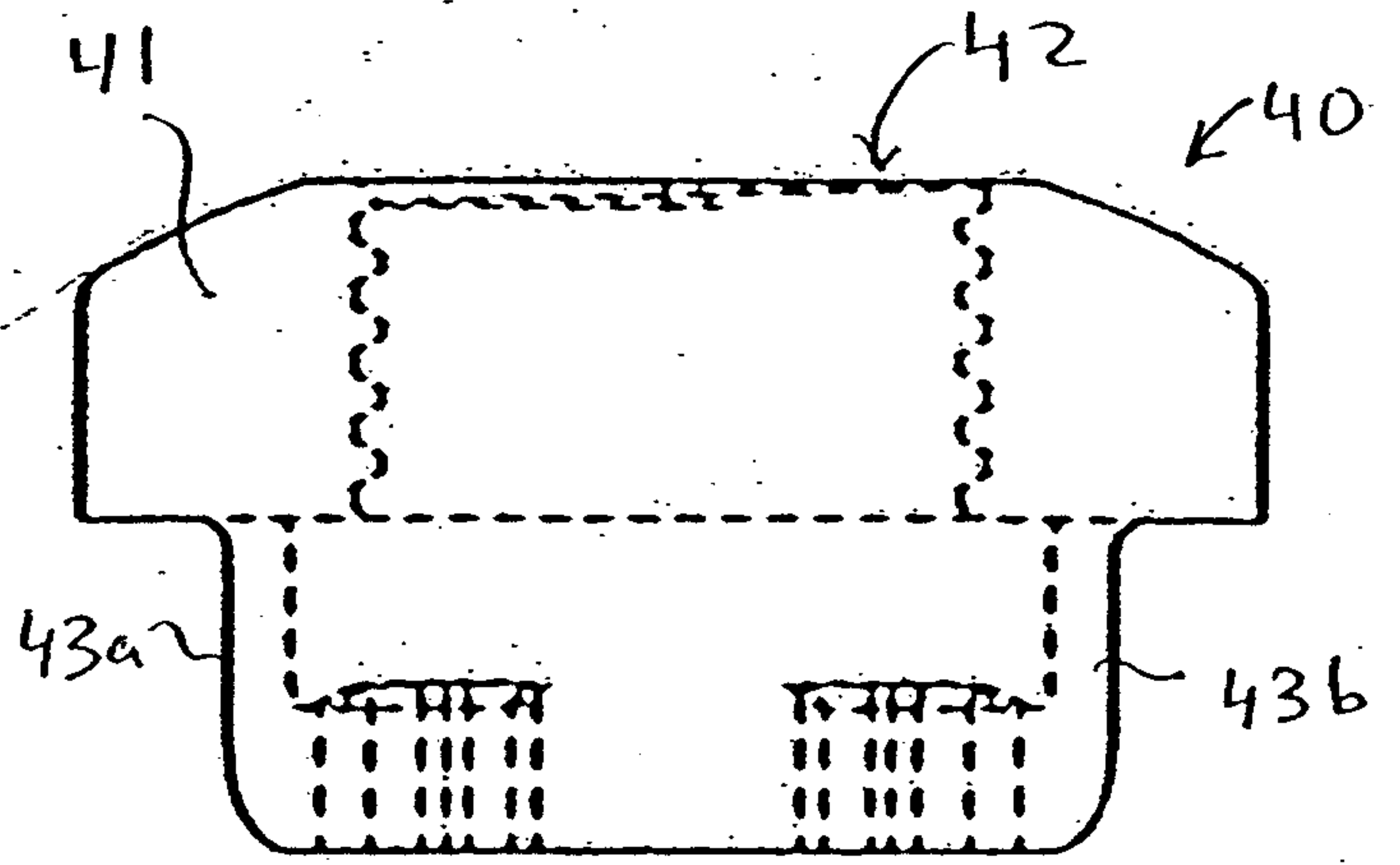

Fig. 3

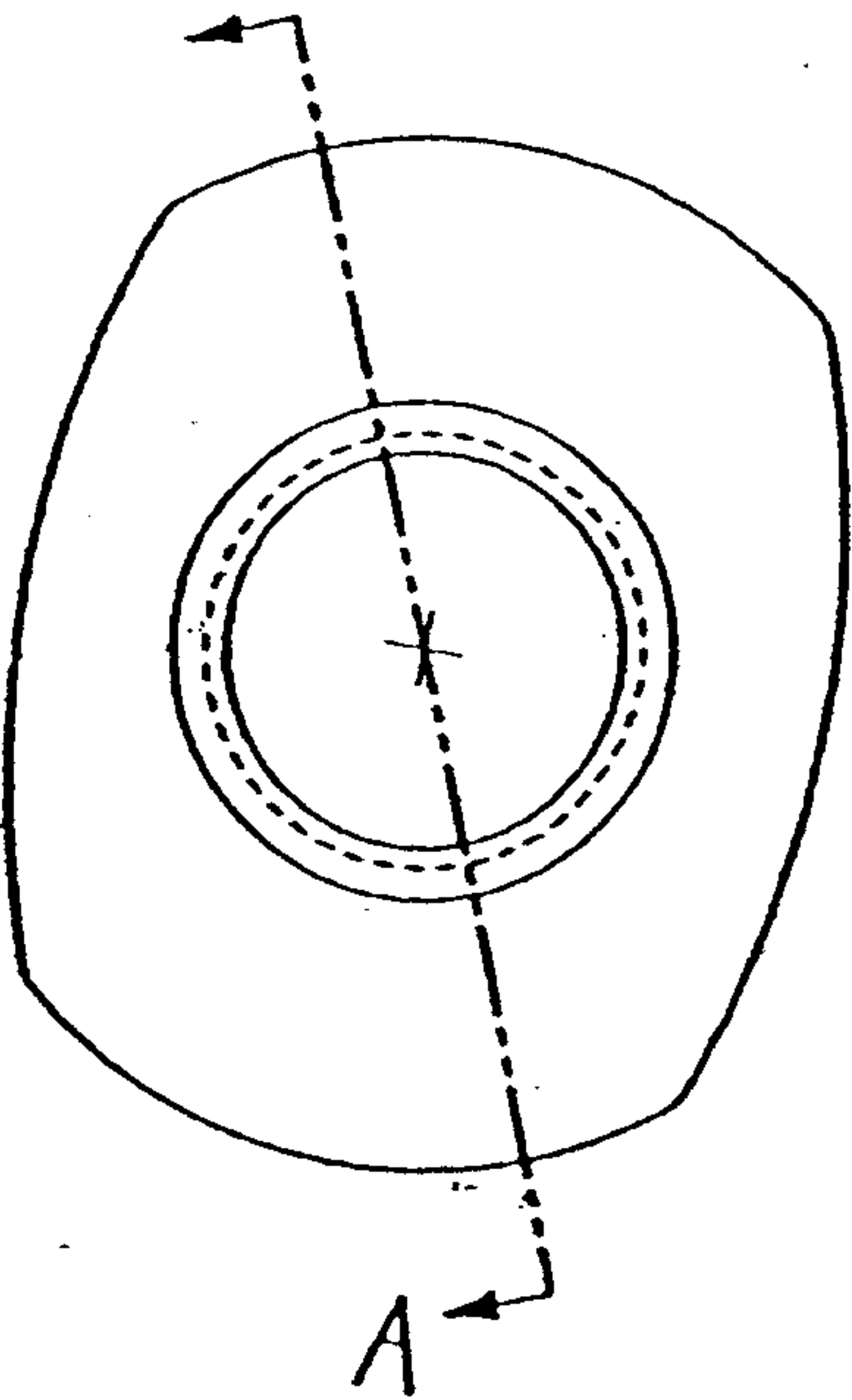

Fig. 3B

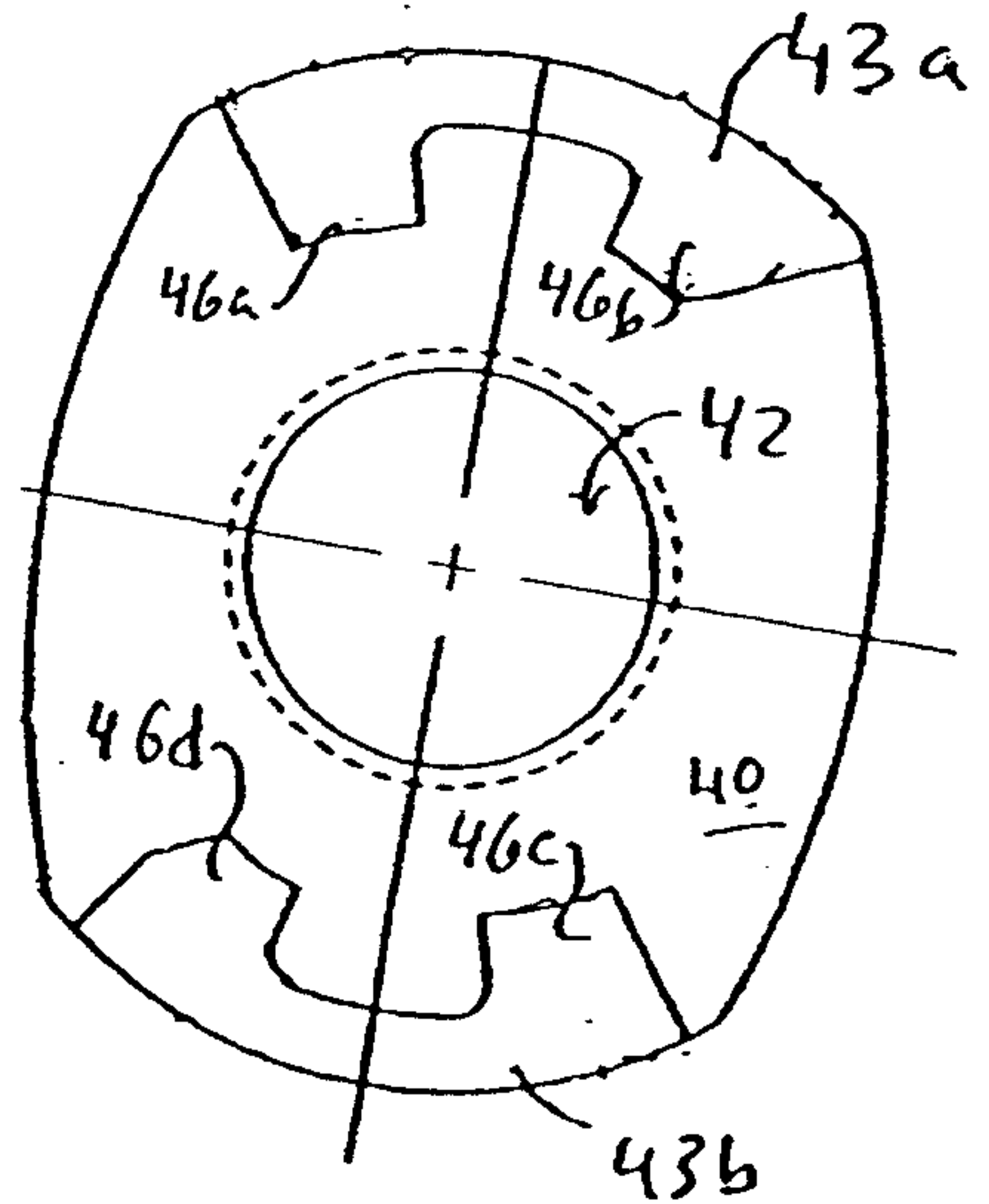

Fig. 3C

4/10

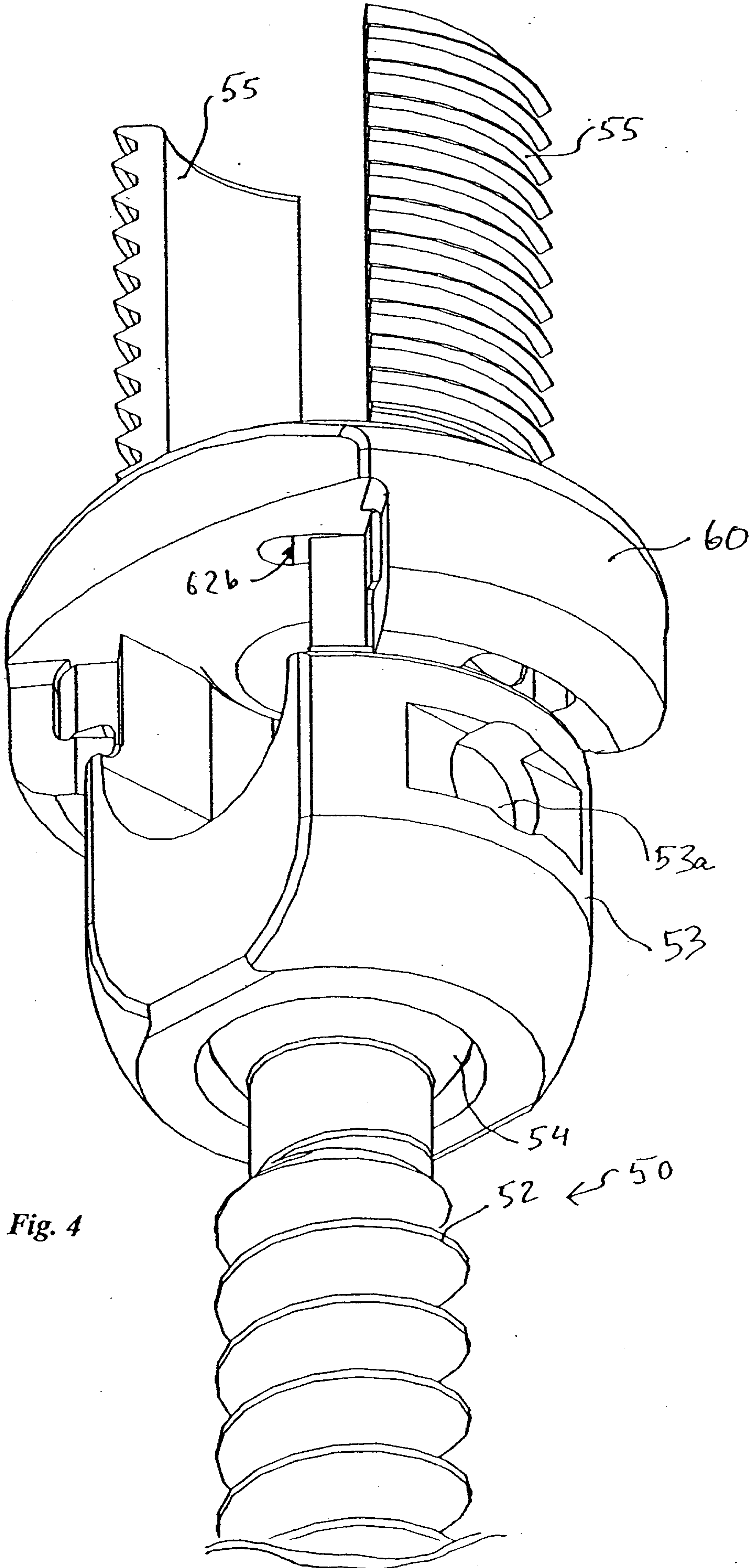

Fig. 4

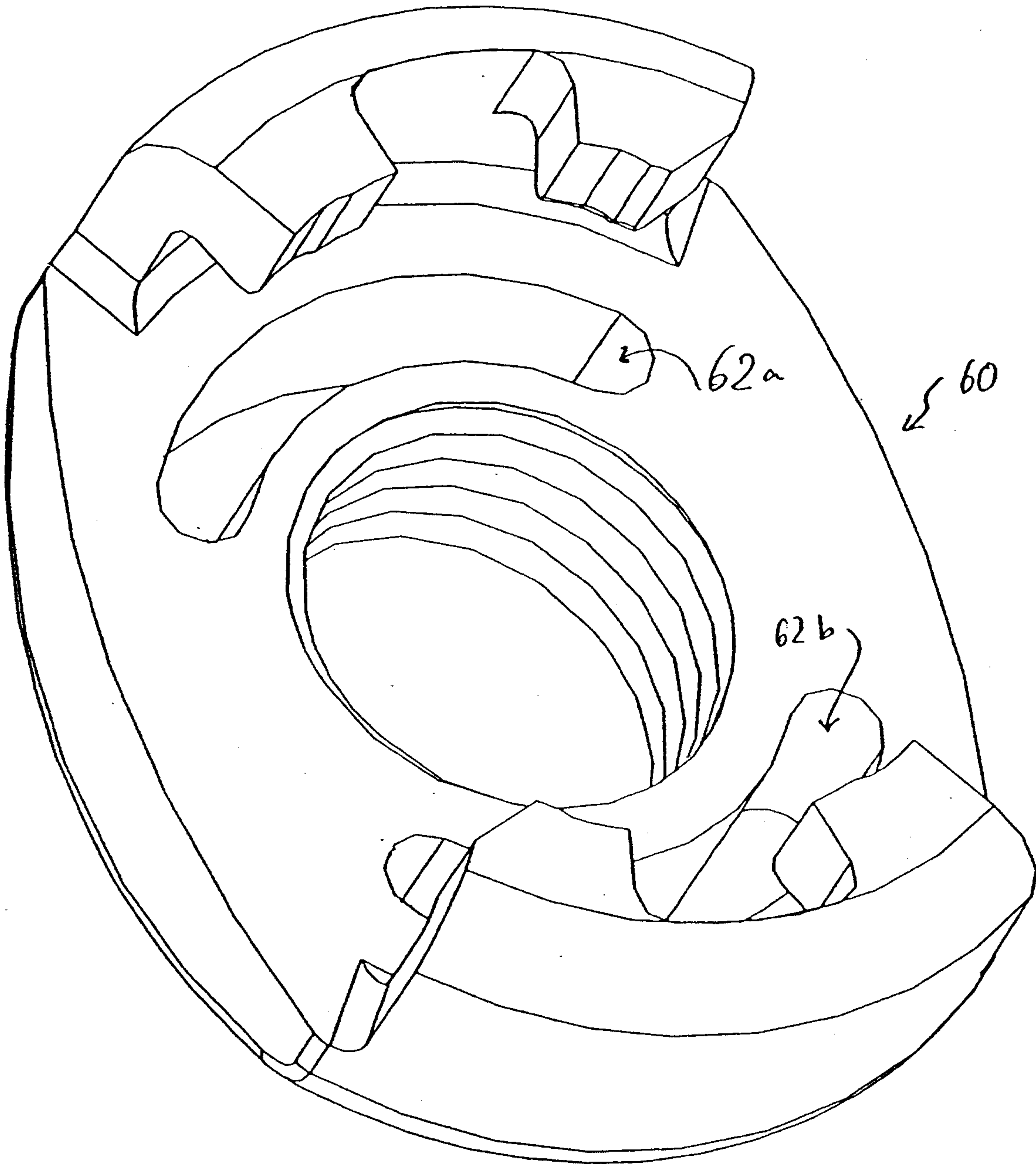

Fig. 4A

6/10

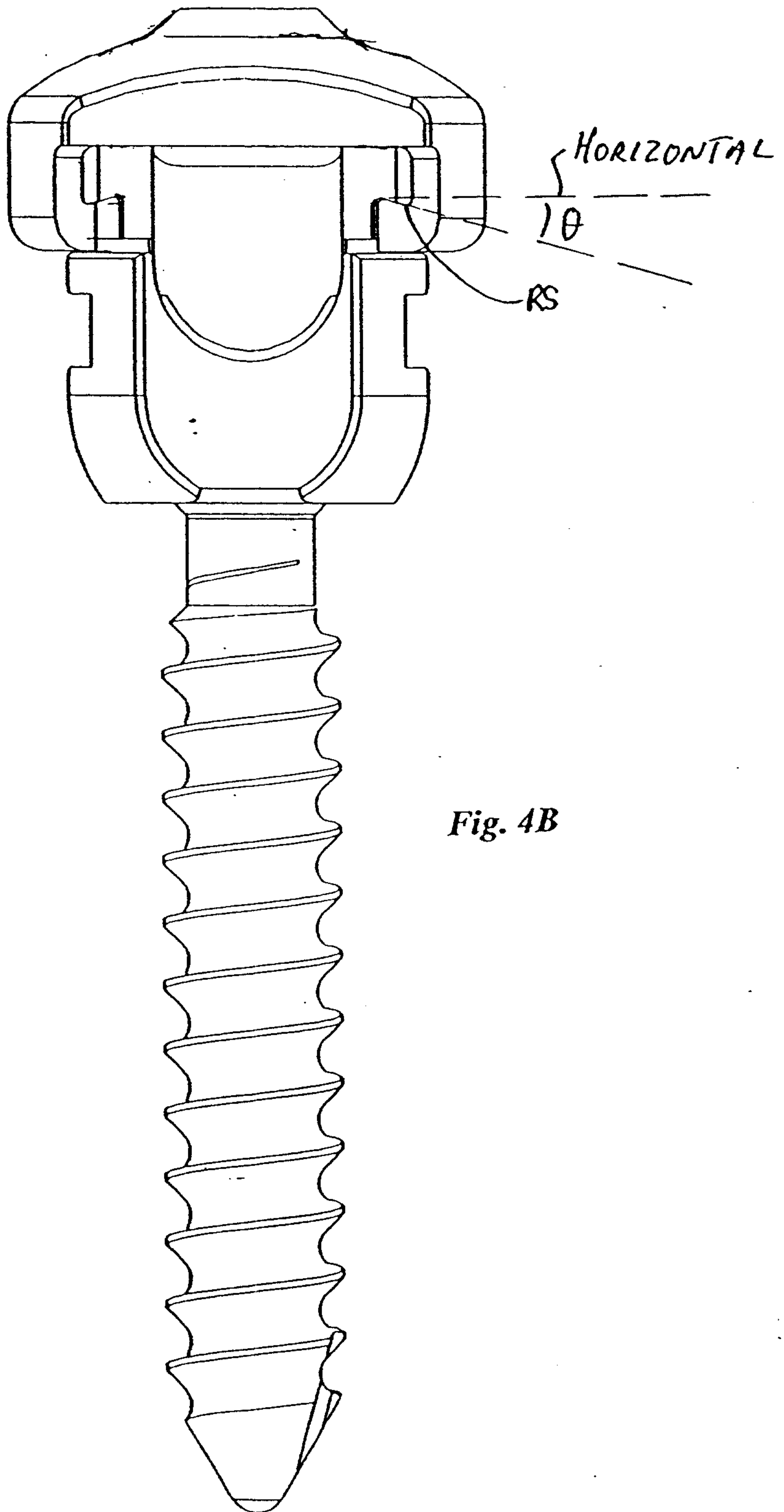

Fig. 4B

7/10

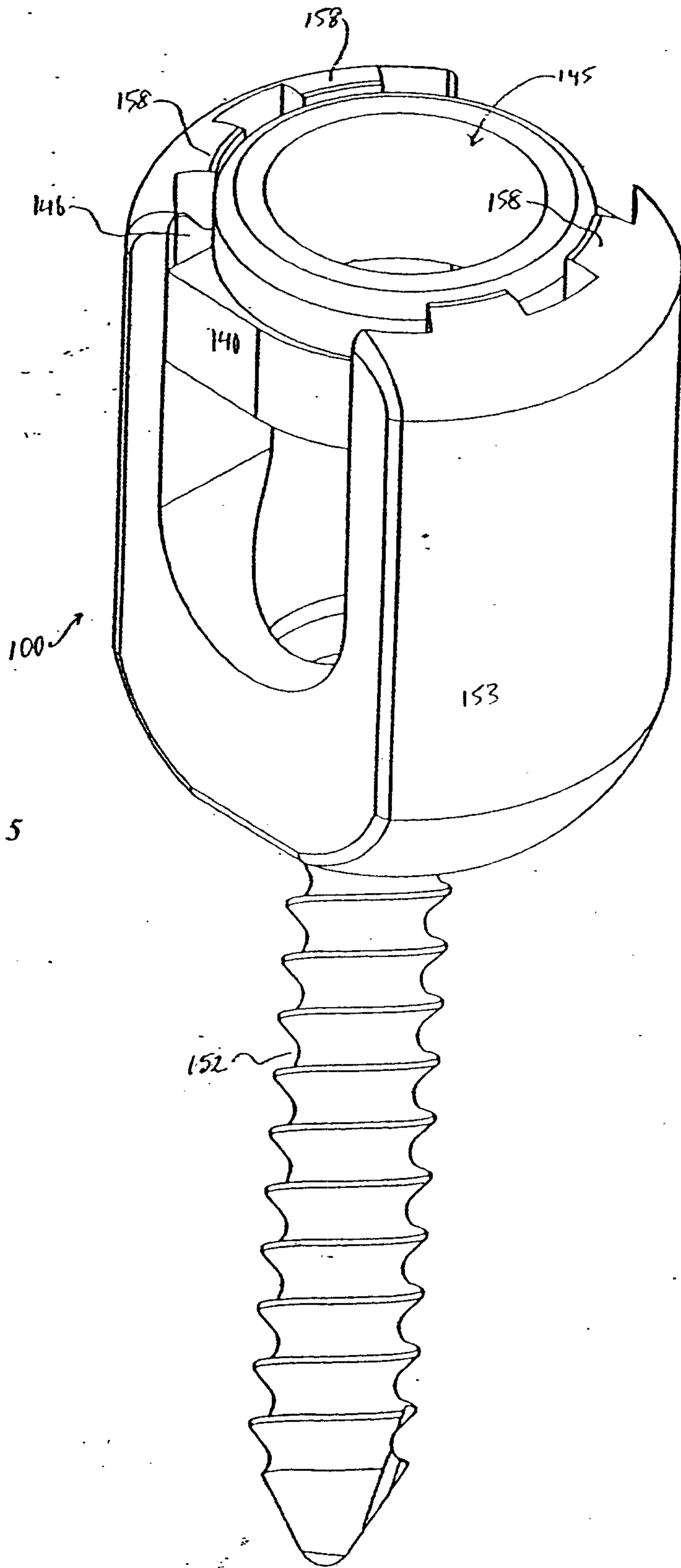
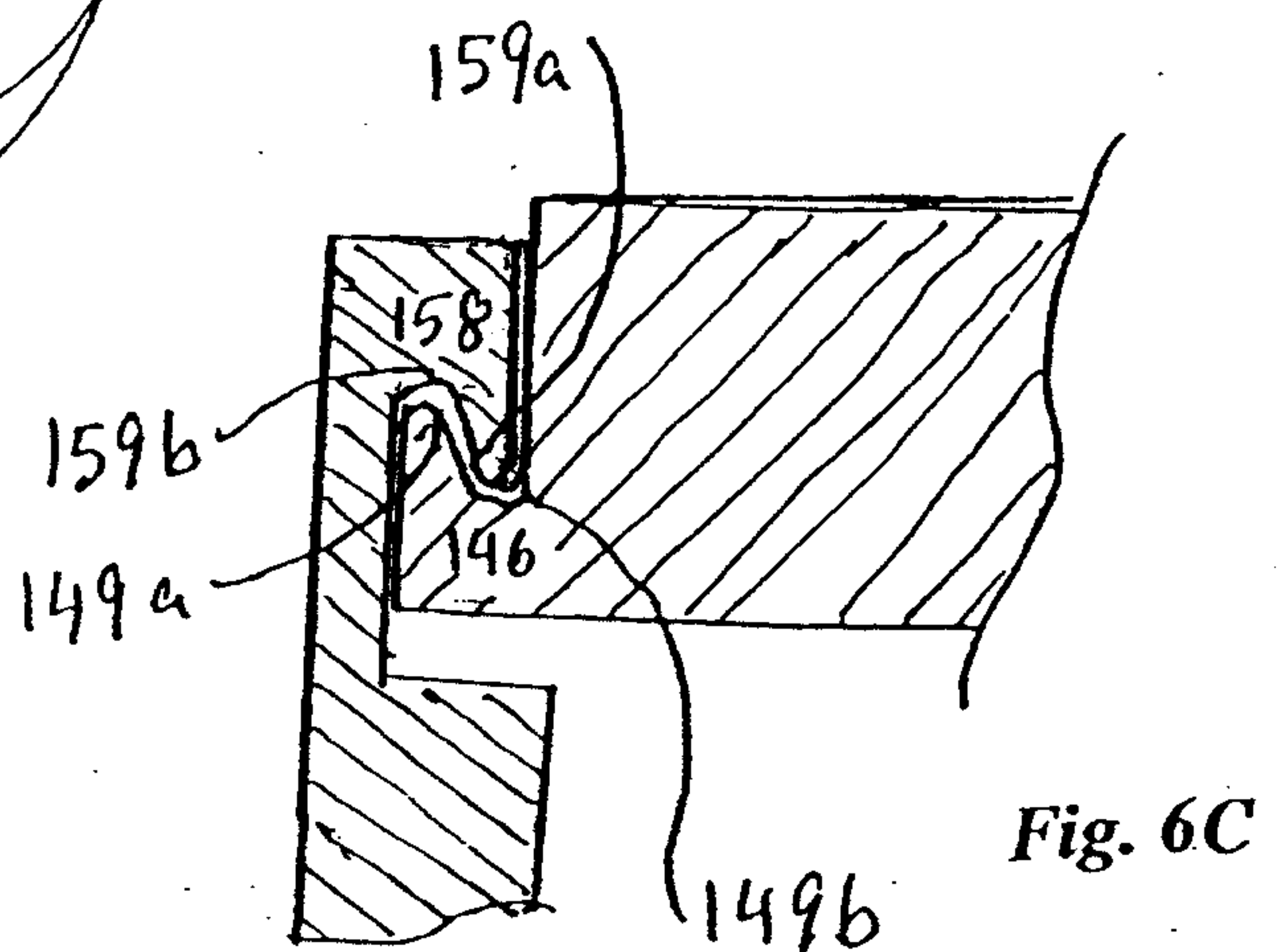
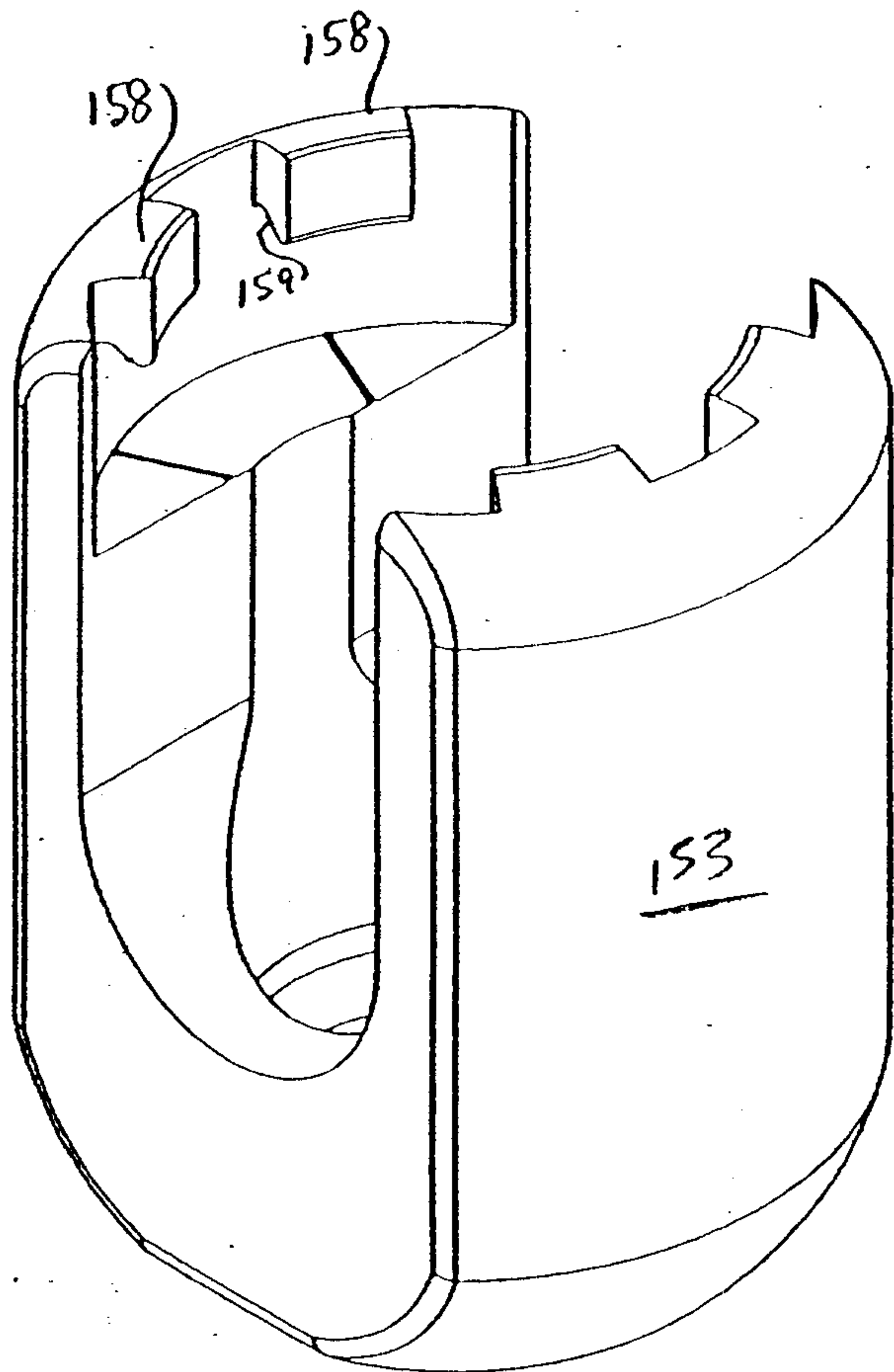
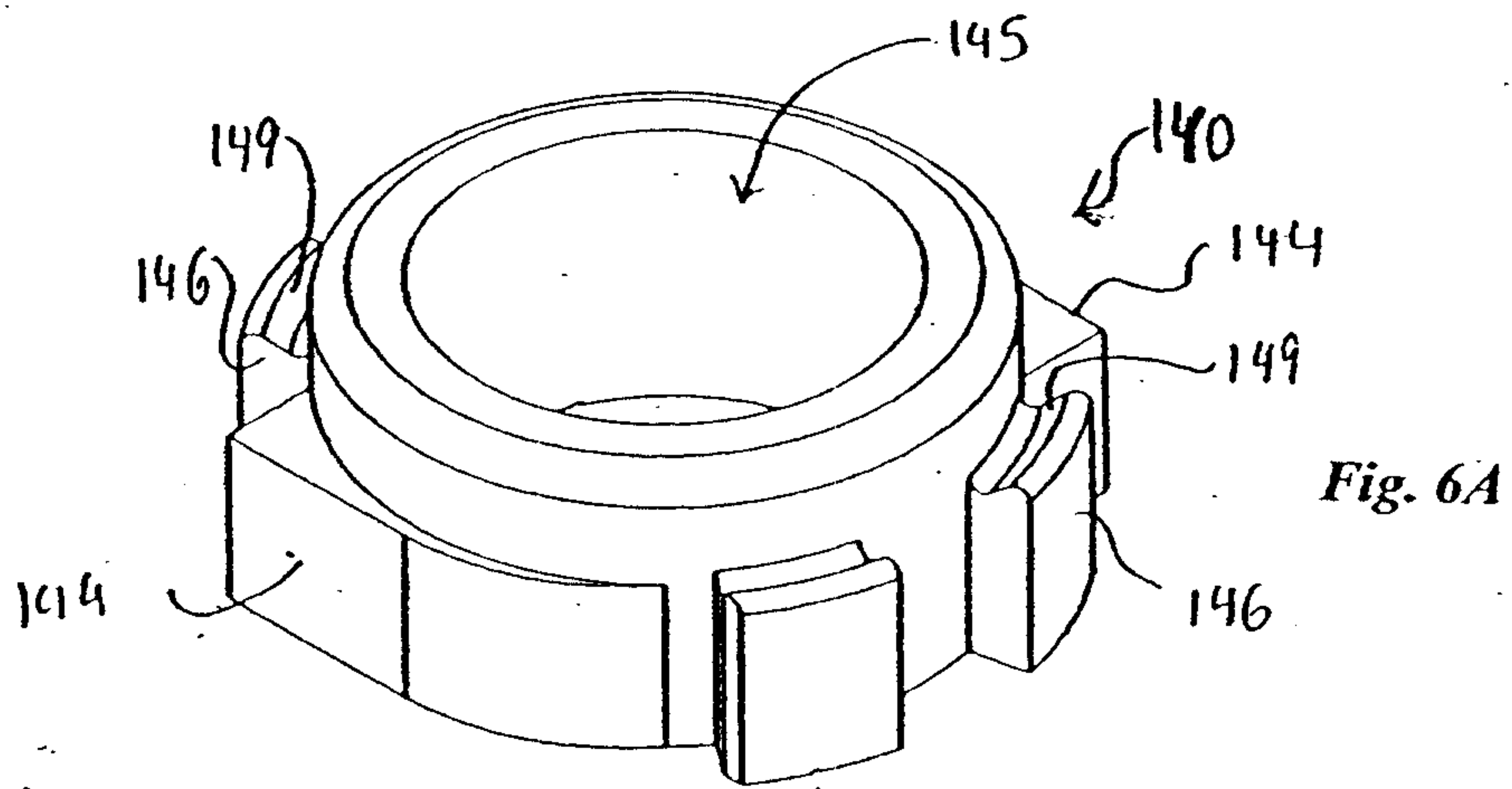
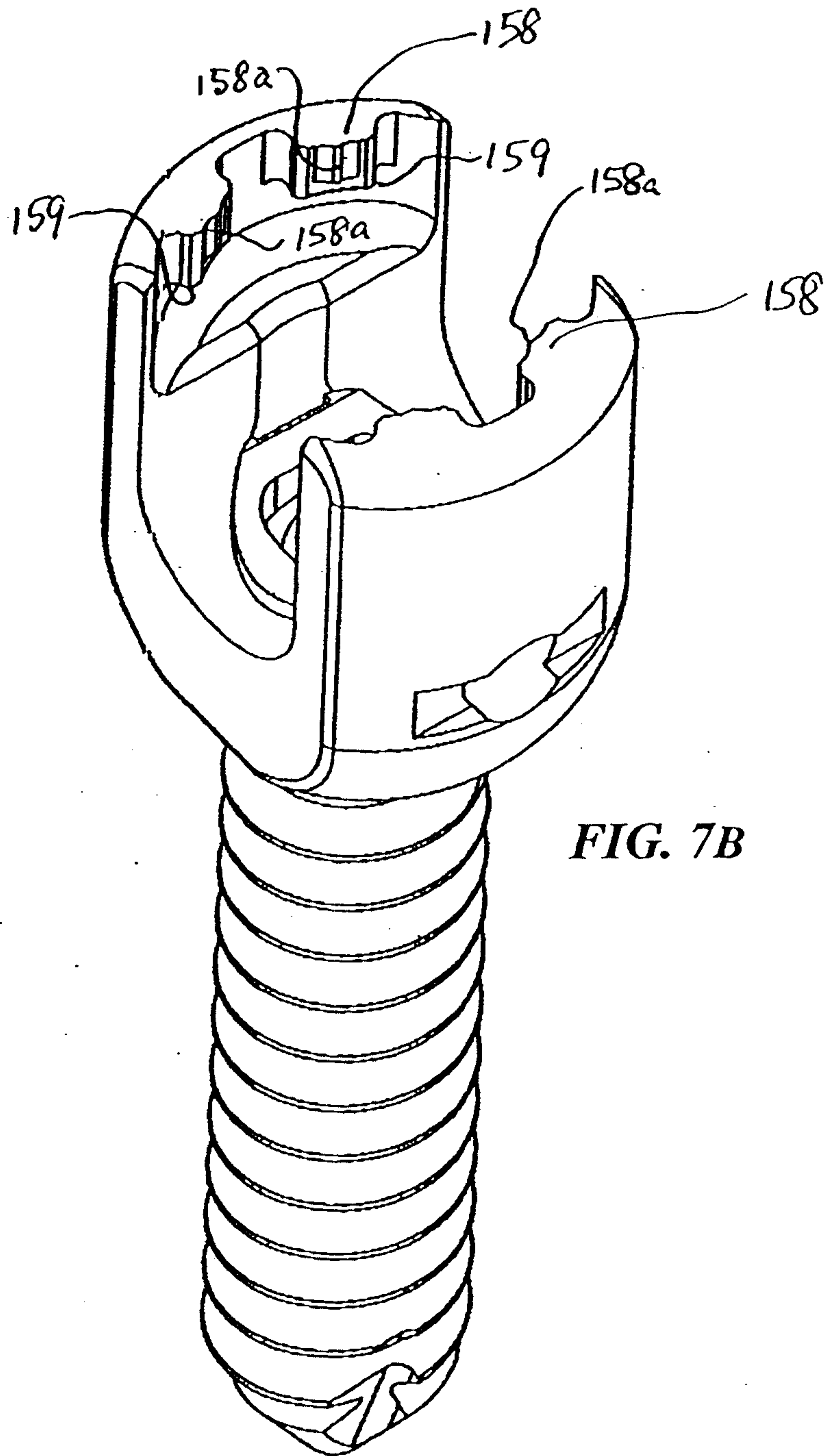
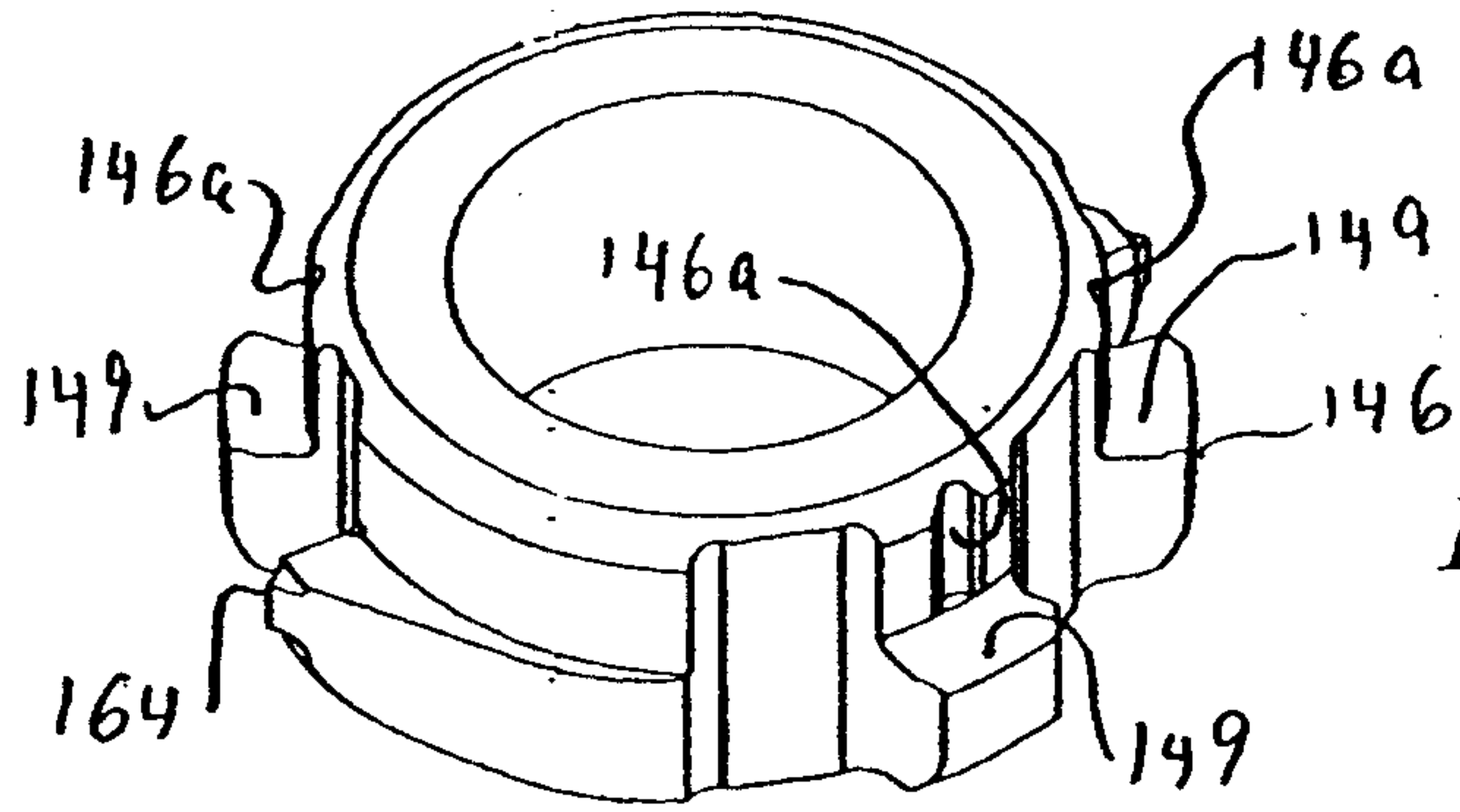

Fig. 5



9/10



10/10

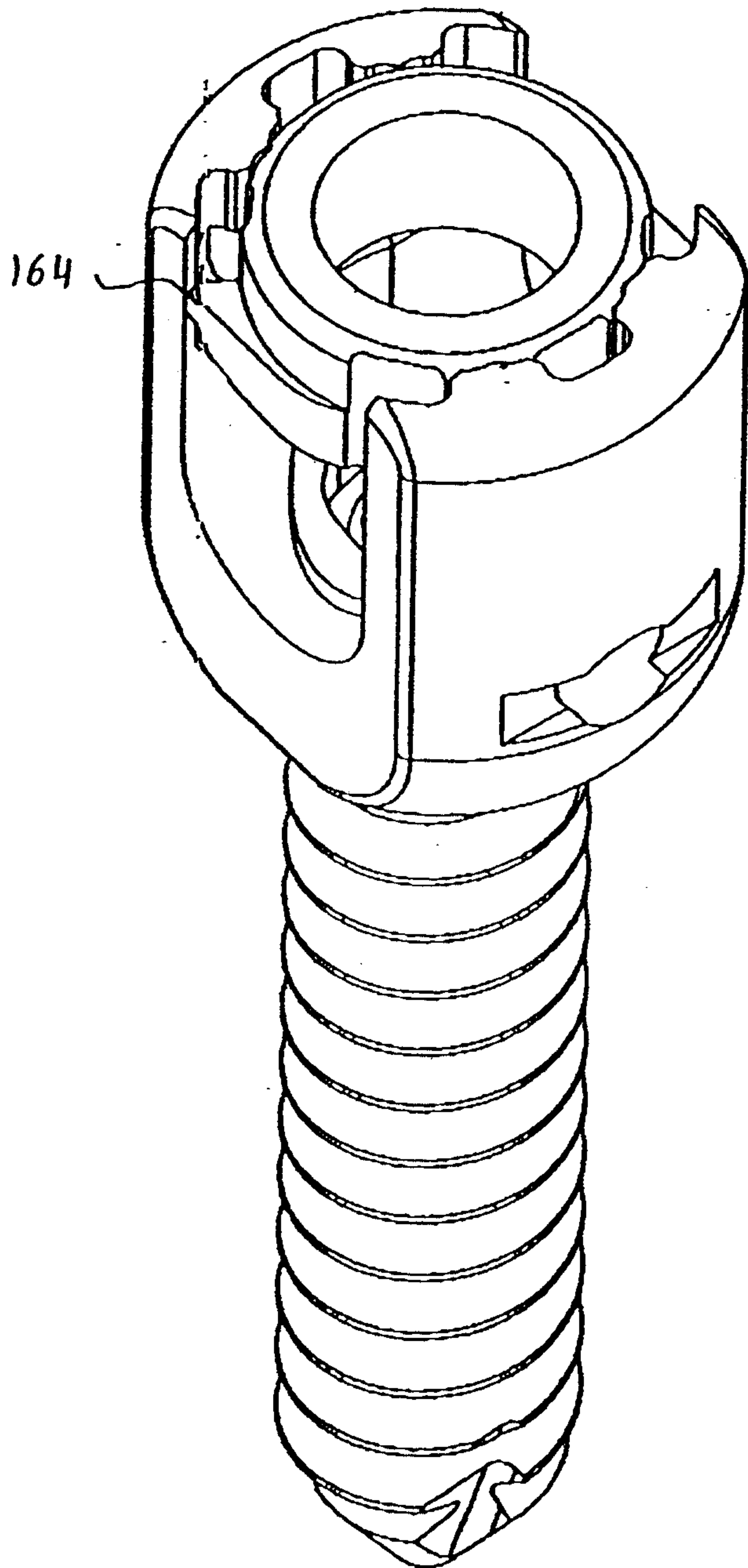

FIG. 7C

