

(19)



(11)

**EP 4 089 334 B1**

(12)

**EUROPEAN PATENT SPECIFICATION**

(45) Date of publication and mention of the grant of the patent:  
**28.02.2024 Bulletin 2024/09**

(51) International Patent Classification (IPC):  
**F24C 15/32<sup>(2006.01)</sup> F24C 14/00<sup>(2006.01)</sup>**

(21) Application number: **22179544.6**

(52) Cooperative Patent Classification (CPC):  
**F24C 15/325; F24C 14/005; F24C 15/327**

(22) Date of filing: **24.07.2019**

(54) **ELECTRIC CONVECTION COOKING OVEN AND METHOD OF OPERATION OF SUCH AN OVEN**

ELEKTRISCHER KONVEKTIONSBACKOFEN UND VERFAHREN ZUM BETRIEB EINES SOLCHEN OFENS

FOUR DE CUISSON ÉLECTRIQUE À CONVECTION ET PROCÉDÉ DE FONCTIONNEMENT D'UN TEL FOUR

(84) Designated Contracting States:  
**AL AT BE BG CH CY CZ DE DK EE ES FI FR GB GR HR HU IE IS IT LI LT LU LV MC MK MT NL NO PL PT RO RS SE SI SK SM TR**

- **GASTALDELLI, Lucio**  
**46037 Roncoferraro MN (IT)**
- **LOCATELLI, Andrea**  
**37134 Verona VR (IT)**
- **RIGHETTI, Marco**  
**46032 Castelbelforte MN (IT)**
- **TOSI, Mauro**  
**37051 Bovolone VR (IT)**

(43) Date of publication of application:  
**16.11.2022 Bulletin 2022/46**

(62) Document number(s) of the earlier application(s) in accordance with Art. 76 EPC:  
**19425057.7 / 3 770 511**

(74) Representative: **Concone, Emanuele et al**  
**Società Italiana Brevetti S.p.A.**  
**Via Carducci 8**  
**20123 Milano (IT)**

(73) Proprietor: **Bonferraro S.p.A.**  
**37060 Bonferraro (VR) (IT)**

(72) Inventors:  
• **ANDREATTA, Antonio**  
**33082 Azzano Decimo PN (IT)**  
• **BICEGO, Luca**  
**37060 Bonferraro di Sorgà VR (IT)**

(56) References cited:  
**EP-A2- 0 401 173 EP-A2- 3 399 237**  
**KR-A- 20050 056 054 US-A1- 2006 011 607**  
**US-A1- 2008 308 545 US-A1- 2018 259 192**  
**US-B2- 7 282 673**

**EP 4 089 334 B1**

Note: Within nine months of the publication of the mention of the grant of the European patent in the European Patent Bulletin, any person may give notice to the European Patent Office of opposition to that patent, in accordance with the Implementing Regulations. Notice of opposition shall not be deemed to have been filed until the opposition fee has been paid. (Art. 99(1) European Patent Convention).

## Description

**[0001]** This invention concerns electric convection ovens for cooking food or semifinished food products, and in particular such an oven provided with a substantially octagonal deflector and also with a steam generator device, especially a professional oven. It is known that there are mainly three types of electric cooking ovens, namely static ovens, convection ovens and convection ovens with steam generators, with progressively increasing performance and costs.

**[0002]** In static ovens the temperature is regulated only by the operating time of an electric resistor, placed on the rear wall of the cooking chamber behind a deflector, which heats the air in the cooking chamber where the circulation takes place by natural convection. The thermal action is simple and rudimentary, since the food does not come into direct contact with the electric resistor but reaches the cooking temperature through the action of the surrounding superheated air. The structural simplicity of the static oven does not allow to act in the cooking chamber with other parameters, such as ventilation and steam, to achieve more sophisticated heat treatments of food.

**[0003]** In convection ovens there is a fan, also placed behind the deflector and preferably inside a circular electric resistor, which causes a forced convection motion of the air inside the cooking chamber. The dynamically forced air distributes the thermal energy better, causing greater penetration into the food, thus obtaining significant advantages compared to static cooking:

- greater efficiency and uniformity of the cooking action, with lower cooking times and temperatures, and consequently a lower weight loss of the food;
- the possibility of handling different foods at the same time, since forced air convection prevents the mixing of smells and flavours in the cooking chamber;
- energy saving associated with a qualitatively superior result.

**[0004]** In convection ovens with steam generator, especially in professional ovens, the user has the possibility to activate the steam function to create an even wider range of cooking, and the steam can also be used for regeneration and maintenance cycles of already cooked foods.

**[0005]** In this type of oven the steam can be generated directly or indirectly: in the first case by nozzles that spray water particles directly on the electric resistor and thanks to the fan that distributes the steam evenly in the cooking chamber, while in the second case by means of an autonomous steam generator (boiler) located inside the structure of the oven but outside the cooking chamber, in which the steam is injected through pipes from the boiler.

**[0006]** In the first case, the generation of steam is linked to the functioning of the cooking resistor, whereby

these ovens cannot cook only with steam, and furthermore the result is a superheated steam that reaches temperatures  $>100^{\circ}\text{C}$  and is more aggressive than saturated steam, so it can give rise to peripheral oxidation, especially of leafy vegetables. In the second case, the oven can also cook only with steam and at a lower temperature, since the functioning of the cooking resistor is not required to generate steam, and the boiler allows to operate at steam saturation with a steam that remains at a constant temperature of about  $100^{\circ}\text{C}$  and is less aggressive for the food, thus avoiding oxidation phenomena.

**[0007]** In these prior art ovens the deflector has a square or rectangular shape with a height almost equal to the height of the cooking chamber and is mounted on the rear wall of the latter at its top and bottom sides through two solid walls that prevent the passage of air, whereas the other two left and right sides have no walls to allow the circulation of air so that the flow extends over the whole height of the cooking chamber. With this simple type of deflector, however, it was found that the air flow exiting through the free sides is poorly uniform in terms of both speed and temperature, which results in an uneven distribution of heat within the cooking chamber and therefore a scarce uniformity of the cooking action.

**[0008]** EP 3399237 discloses an oven according to the preamble of claim 1 having a structure capable of easily removing oil mist generated when food is cooked, so as to minimize contamination of an inner surface of a cavity of the oven thus making unnecessary to resort to a pyro-cleaning method or a steam cleaning method to remove such internal contamination. To this purpose, the oven has a convection assembly that includes a deflector with an inlet port in a front surface and outlet ports in a side surface extending from the front surface to the rear wall of the cavity, wherein the air discharged from the deflector moves in an upward inclined direction with respect to the rear wall.

**[0009]** Such an oven is designed to minimize the contamination of the internal cavity but does not take into account the problems caused by the specific shape of the deflector as to the distribution of heat within the cavity.

**[0010]** US 2006/0011607 discloses an oven with a steam-generating device installed behind a conventional deflector and under the cooking resistor for supplying steam to the cooking chamber. In this oven, the steam is generated by a specific heater that is housed in a heating container closed by a cover member with the interposition of a seal for maintaining an airtight state. As a consequence, the water supply pipe and the steam-generating heater must pass through properly sealed passages in said cover, and the steam generated in the heating container is delivered to the cooking chamber through suitable exhaust pipes that also must pass through cover. In practice, this arrangement corresponds to having the above-mentioned boiler located within the cooking chamber.

**[0011]** Document EP0401173 A2 further discloses an oven comprising an octagonal deflector, without steam

generating function.

**[0012]** The purpose of this invention is therefore to provide an oven that is free from the above-described drawbacks. This purpose is achieved with an oven equipped with a deflector of semi-regular octagonal shape deriving from a rectangle or a square with bevelled corners that, in addition to the two solid walls along the top and bottom sides, also includes two pairs of oblique peripheral walls that are respectively adjacent to said top and bottom walls and are provided with openings extending over 30-90% of the area of said oblique walls, as well as two lateral walls extending between the oblique walls and also having openings, the oven further including a water supply duct extending from the rear wall of the cooking chamber, a tray located inside the cooking chamber in a position to receive the water supplied through said duct, and a second resistor that extends into said tray so that most of said second resistor is immersed in water when the tray is filled, the deflector protecting a user also from contact with the second resistor. Further advantageous features are recited in the dependent claims.

**[0013]** A first important advantage of this oven is to improve the cooking performance thanks to the greater uniformity of the air flow exiting the deflector in terms of both speed and temperature, which results in a more even distribution of heat within the cooking chamber and therefore a more uniform cooking.

**[0014]** A second significant advantage of this oven is that of improving the performance of the steam generator in terms of speed and energy efficiency, because the saturated steam is generated directly inside the cooking chamber instead of coming from a device external to it as a traditional boiler, whereby the steam does not pass through the supply pipes where it cools down and disperses heat outside the cooking chamber. In this case, there is the further advantage of being able to use the steam generating resistor also for cooking when the tray is empty, which is not possible with the arrangement disclosed in US 2006/0011607, given the position in which it is located, so as to obtain a reduction in energy consumption thanks to the better efficiency of the system. For example, a 6 KW cooking resistor can be used to immediately bring the oven to temperature and then a 2 KW steam resistor can be used to maintain the temperature during cooking, thus obtaining lower power jumps when the oven thermostat switches the resistor on and off.

**[0015]** Still another important advantage of the above-mentioned oven is the reduction in the number and complexity of its components, since the steam generator inside the cooking chamber is much simpler than the external boiler or the arrangement disclosed in US 2006/0011607, and does not require connections with the cooking chamber. In this way, with the same performance, a considerable economic saving is obtained both in the production phase and in the maintenance of the oven.

**[0016]** Further advantages and characteristics of the

oven according to the present invention will be evident to those skilled in the art from the following detailed description of some embodiments thereof with reference to the annexed drawings, in which:

Fig.1 is a front view of a prior art oven with a square deflector;

Fig.2 is a frontal perspective view of a preferred embodiment of the oven, provided with a steam generator, with some components removed for greater clarity;

Fig.3 is a partial enlarged view of the oven of Fig.2 with the addition of a couple of components;

Fig.4 is a magnified perspective view of the water diffuser;

Fig.5 is a rear perspective view of the deflector; and

Fig.6 is a frontal perspective view of the oven with the deflector.

**[0017]** Referring to Fig.1, there is seen that a prior art oven with direct steam generator traditionally includes a square deflector 1 mounted on the rear wall 2 of the cooking chamber, deflector 1 being formed by a front wall and peripheral walls at its top and bottom sides, that are close respectively to the ceiling and floor of the cooking chamber. The square deflector 1 protects the user from contact with the elements (cooking resistor and fan) mounted on the rear wall 2, and it is provided with holes for the passage of a duct 3 to supply the water used to generate the steam. Duct 3 extends from the rear wall 2 and passes in front of deflector 1, with a section parallel to the rear wall 2, to end inside it with an end section preferably coaxial to a centrally arranged circular intake grille 1a.

**[0018]** The oven according to the present invention, shown in figures 2 to 4, conventionally includes a cooking resistor 4 mounted on the rear wall 2 and having preferably a circular shape so as to receive inside it a fan 5, preferably coaxial thereto, to realize the forced convection of the air heated by resistor 4.

**[0019]** A first aspect of this oven lies in the presence inside the cooking chamber of a tray 6, arranged in such a position as to receive the water fed through duct 3, and of a second resistor 7 that extends into said tray 6 so that most of resistor 7 is immersed in water when tray 6 is filled. In this way, resistor 7 can be used to generate saturated steam directly inside the cooking chamber, which steam is then distributed by fan 5, as mentioned above.

**[0020]** Note that since the water fed through duct 3 is not used to generate superheated steam by spraying it on the cooking resistor 4, duct 3 does not have a spray nozzle on its outlet. However, it is preferable that the water is not simply delivered from duct 3 directly into tray 6, whereby the present oven preferably includes a diffuser 8 which is mounted so as to surround the outlet of duct 3, being preferably mounted in the centre of fan 5.

**[0021]** This diffuser 8, as better illustrated in Fig.4, has a cylindrical shape with a plurality of circumferential

grooves 8a formed internally, preferably with a constant pitch, and a plurality of radial holes 8b made in correspondence of said grooves 8a preferably along the entire perimeter of diffuser 8. Thanks to this structure, diffuser 8 performs a controlled release of the water supplied by duct 3 distributing it in tray 6 even while diffuser 8 rotates with fan 5.

**[0022]** In the embodiment shown in Fig.2, tray 6 is a separate component mounted on the rear wall 2 same as the other components 4, 5 and 7, tray 6 being preferably in a centered position with respect to fan 5. However, the tray could also be integrated into the deflector as shown in the following.

**[0023]** A second aspect of the present oven resides in the octagonal shape of the deflector, instead of a square shape like the prior art deflector 1 shown in Fig.1, with a number of openings formed in the peripheral walls. In particular, as illustrated in figures 5 and 6, deflector 21 has the shape of a semi-regular octagon deriving from a rectangle with bevelled corners, but it could obviously be also a square with bevelled corners, in which the peripheral walls 9, 10 respectively arranged along the top and bottom sides are solid walls, whereas the other peripheral walls are provided with elongated openings (slots) extending over 30-90% of the area of said walls.

**[0024]** More specifically, the two pairs of oblique walls 11, 12 respectively adjacent to said top and bottom walls 9, 10 are provided with four slots 11a, 12a with the former extending over about 80% of the relevant walls 11 and the latter extending over about 40% of the relevant walls 12, while the lateral walls 13 have four slots 13a extending over about 60% thereof. This different extension of the slots in the oblique walls 11, 12 is due to the fact that the lower portion of deflector 21 is taken up by tray 6 or performs the function of tray 6 itself, by means of the bottom wall 10 that has a raised rear edge 14 so that the lower portion of the deflector can contain the water to be turned into steam (resistor 7 being obviously housed in this lower portion).

**[0025]** As shown in Fig.6, deflector 21 is preferably of reduced height compared to the cooking chamber because its top wall 9 and bottom wall 10 are not near respectively the ceiling and the floor of the cooking chamber as in prior art deflector 1 illustrated in Fig.1. Moreover, thanks to the presence of oblique walls 11, 12, all the peripheral walls of the deflector are preferably located close to the cooking resistor, which is typically circular, and the applicant has found that this arrangement allows the flow to be uniformed in an optimal manner both in terms of speed profile and temperature profile. Such a deflector geometry is also more compact, which facilitates both maintenance and cleaning in the cooking chamber.

**[0026]** A third aspect of this invention, in a preferred embodiment thereof, is given by the greater extension in the vertical direction of the front intake grille of the deflector.

**[0027]** This allows to improve the air suction and dis-

tribution along the height of the deflector and consequently to optimize the heat distribution on the different shelves arranged at different heights in the cooking chamber. Note that this can also be achieved by providing for additional intake grilles above and below the traditional circular intake grille 1a.

**[0028]** Both the cooking resistor 4 and the steam resistor 7 can be composed of multiple units (e.g. 3 x 2 KW for resistor 4, 2 x 1 KW for resistor 7), the peripheral slots of the deflector can have other shapes and/or different positions in the respective walls and the relative arrangement of the components can vary depending on specific construction requirements (e.g. duct 3 could follow a different path to supply water to tray 6).

## Claims

1. Electric convection cooking oven comprising a cooking chamber, a cooking resistor (4) and a fan (5) both mounted on the rear wall (2) of said cooking chamber and a deflector (21), formed by a front wall and peripheral walls, mounted on said rear wall (2) so as to protect a user from contact with said cooking resistor (4) and said fan (5), said deflector (21) being provided with solid peripheral walls (9, 10) at its top and bottom sides and at least one central intake grille (1a) in said front wall, the deflector (21; 22) having a substantially octagonal shape that also includes two pairs of oblique peripheral walls (11, 12), which are respectively adjacent to said top and bottom walls (9, 10) and have openings (11a, 12a) that extend over 30-90% of the area of said oblique walls (11, 12), as well as two lateral peripheral walls (13) that extend between the oblique walls (11, 12), **characterized in that** the deflector (21) has the shape of a semi-regular octagon deriving from a rectangle or a square with bevelled corners, with also the side walls (13) having openings (13a), and **in that** it further includes a water supply duct (3) extending from the rear wall (2) of the cooking chamber, a tray (6), located inside the cooking chamber in a position to receive the water supplied through said duct (3), and a second resistor (7) that extends into said tray (6) so that most of said second resistor (7) is immersed in water when the tray (6) is filled, the deflector (21) protecting a user also from contact with the second resistor (7).
2. Oven according to claim 1, **characterized in that** in the two oblique walls (11) that are adjacent to the top wall (9) there are formed openings (11a) that extend over about 80% of said oblique walls (11).
3. Oven according to claim 1 or 2, **characterized in that** in the two oblique walls (12) that are adjacent to the bottom wall (10) there are formed openings (12a) that extend over about 40% of said oblique

walls (12).

4. Oven according to any of claims 1 to 3, **characterized in that** in the two lateral walls (13) there are formed openings (13a) that extend over about 60% of said lateral walls (13). 5
5. Oven according to any of the preceding claims, **characterized in that** the deflector (21) is of reduced height compared to the cooking chamber so that its top wall (9) and bottom wall (10) are not near respectively to the ceiling and the floor of the cooking chamber, and the peripheral walls of the deflector (21) are arranged close to the cooking resistor (4). 10
6. Oven according to any of the preceding claims, **characterized in that** the central intake grille (1a) extends more vertically than horizontally, preferably with an elliptical shape, or additional intake grilles are formed above and below said central intake grille (1a). 20
7. Oven according to any of the preceding claims, **characterized in that** it further includes a diffuser (8) mounted so as to surround the outlet of the water supply duct (3), said diffuser (8) having a cylindrical shape with a plurality of circumferential grooves (8a) formed internally, preferably with a constant pitch, and a plurality of through radial holes (8b) made in correspondence of said circumferential grooves (8a), preferably along the entire perimeter of the diffuser (8). 25 30
8. Oven according to any of the preceding claims, **characterized in that** the tray (6) is integrated in the deflector (21) which has a solid bottom wall (10) and has a raised rear edge (14) such that the lower portion of the deflector (21) can contain the water supplied by the duct (3) and accommodate the second resistor (7). 35 40
9. Oven according to any of the preceding claims, **characterized in that** the cooking resistor (4) has a circular shape and the fan (5) is mounted within said circular shape, preferably coaxial thereto. 45
10. Oven according to the preceding claim, **characterized in that** the water supply duct (3) passes in front of the cooking resistor (4) and ends inside said circular shape, preferably with an end section coaxial thereto. 50
11. Method of operation of an oven according to any of the preceding claims, including a step of heating the oven by activating the cooking resistor (4) up to a set cooking temperature and then deactivating the cooking resistor (4), **characterized in that** the maintenance of said cooking temperature is obtained by

activating and deactivating the second resistor (7).

12. Method of operation of an oven according to any of claims 1 to 10, including a step of washing of the cooking chamber with a washing/rinse fluid, **characterized in that** said washing step is performed using vapours of washing/rinse fluid obtained by loading the tray (6) with a mixture of water and detergent and activating the second resistor (7). 5 10

#### Patentansprüche

1. Elektrischer Konvektionsbackofen, umfassend eine Garkammer, einen Kochwiderstand (4) und einen Ventilator (5), wobei die beiden an der Rückwand (2) der besagten Garkammer befestigt sind, sowie einen Deflektor (21), der von einer Vorderwand und von Umfangswänden gebildet wird, und der an der Rückwand (2) montiert ist, um einen Anwender vor einem Kontakt mit dem besagten Kochwiderstand (4) und dem besagten Ventilator (5) zu schützen, wobei der besagte Deflektor (21) an seiner Ober- und Unterseite mit festen Umfangswänden (9, 10) versehen ist sowie mit wenigstens einem mittigen Ansauggitter (1a) in der besagten Vorderwand, wobei der Deflektor (21; 22) eine substantiell achteckige Gestalt aufweist, die auch zwei Paar von schrägen Außenwänden (11, 12) umfasst, welche jeweils an die besagte obere und untere Wand (9, 10) angrenzen und Öffnungen (11a, 12a) aufweisen, die sich über 30-90 % der Fläche der besagten schrägen Außenwände (11, 12) erstrecken, sowie zwei seitliche Umfangswände (13), welche sich zwischen den schrägen Wänden (11) erstrecken, **dadurch gekennzeichnet, dass** der Deflektor (21) die Gestalt eines halbbregulären Achtecks aufweist, das sich von einem Rechteck oder einem Quadrat mit abgescrägten Ecken ableitet, wobei die Seitenwände (13) ebenfalls Öffnungen (13a) aufweisen, sowie dadurch, dass er zusätzlich eine Wasserzuführungsleitung (3) umfasst, die von der Rückwand (2) der Garkammer ausgeht, einen Trog (6), der sich innerhalb der Garkammer an einer Stelle befindet, wo er das durch die besagte Leitung (3) zugeführte Wasser aufnimmt, und einen zweiten Widerstand (7), der sich in dem besagten Trog (6) erstreckt, derart, dass der größte Teil des zweiten Widerstandes (7) in das Wasser eintaucht, wenn der Trog (6) gefüllt ist, wobei der Deflektor (21) den Anwender auch vor einem Kontakt mit dem zweiten Widerstand (7) schützt. 25 30 35 40 45
2. Ofen gemäß dem vorangehenden Anspruch 1, **dadurch gekennzeichnet, dass** in den zwei schrägen Wänden (11), die nächstliegend zu der oberen Wand (9) sind, Öffnungen (11a) ausgebildet sind, die sich über 80 % der besagten schrägen Wände (11) erstrecken. 50 55

3. Ofen gemäß Anspruch 1 oder 2, **dadurch gekennzeichnet, dass** in den zwei schrägen Wänden (12), die nächstliegend zu der unteren Wand (10) sind, Öffnungen (12a) ausgebildet sind, die sich über 40 % der besagten schrägen Wände (12) erstrecken.
4. Ofen gemäß einem der Ansprüche 1 bis 3, **dadurch gekennzeichnet, dass** in den zwei Umfangswänden (13) Öffnungen (13a) geformt sind, die sich über 60 % der besagten Umfangswände (13) erstrecken.
5. Ofen gemäß einem der vorhergehenden Ansprüche, **dadurch gekennzeichnet, dass** der Deflektor (21) eine im Vergleich zur Garkammer geringere Höhe aufweist, so dass seine obere Wand (9) und seine untere Wand (10) nicht nahe der Decke bzw. dem Boden der Garkammer sind, und die Umfangswände des Deflektors (21) nahe bei dem Kochwiderstand (4) angeordnet sind.
6. Ofen gemäß einem der vorhergehenden Ansprüche, **dadurch gekennzeichnet, dass** das mittige Ansauggitter (1a) sich mehr vertikal als horizontal erstreckt, vorzugsweise ellipsenförmig, oder dass zusätzliche Ansauggitter oberhalb oder unterhalb des besagten mittigen Ansauggitters (1a) ausgebildet sind.
7. Ofen gemäß einem der vorhergehenden Ansprüche, **dadurch gekennzeichnet, dass** er ferner einen Diffusor (8) umfasst, welcher derart montiert ist, dass er die Auslassöffnung der Wasserzuführungsleitung (3) umgibt, wobei der besagte Diffusor (8) eine zylindrische Gestalt aufweist mit einer Mehrzahl von innen ausgeformten, umlaufenden Rillen (8a), vorzugsweise mit einer konstanten Steigung, sowie eine Mehrzahl von radialen Durchgangslöchern (8b), die entsprechend der besagten umlaufenden Rillen (8a) ausgebildet sind, vorzugsweise entlang des gesamten Umfangs des Diffusors (8).
8. Ofen gemäß einem der vorhergehenden Ansprüche, **dadurch gekennzeichnet, dass** der Trog (6) in dem Deflektor (21) integriert ist, der eine feste Bodenwand (10) und eine erhöhte hintere Kante (14) aufweist, so dass der untere Bereich des Deflektors (21) das über die Leitung (3) zugeführte Wasser enthalten kann und den zweiten Widerstand (7) aufnehmen kann.
9. Ofen gemäß einem der vorhergehenden Ansprüche, **dadurch gekennzeichnet, dass** der Kochwiderstand (4) eine runde Form aufweist und der Ventilator (5) innerhalb der runden Form angeordnet ist, vorzugsweise coaxial dazu.
10. Ofen gemäß dem vorhergehenden Anspruch, **dadurch gekennzeichnet, dass** die Wasserzuführungs-

ungsleitung (3) vor dem Widerstand (4) vorbeiläuft und innerhalb der besagten runden Form endet, vorzugsweise mit einem dazu coaxialen Endbereich.

- 5 11. Verfahren zum Betrieb eines Ofens nach einem der vorhergehenden Ansprüche, umfassend einen Schritt des Aufheizens des Ofens auf eine gewählte Koch-Temperatur durch Einschalten des Kochwiderstandes (4) und anschließendes Ausschalten des Kochwiderstandes (4), **dadurch gekennzeichnet, dass** die Aufrechterhaltung der besagten Koch-Temperatur durch Ein- und Ausschalten des zweiten Widerstands (7) erreicht wird.
- 10 12. Verfahren zum Betrieb eines Ofens nach einem der Ansprüche 1 bis 10, umfassend einen Schritt des Waschens der Garkammer mit einer Wasch-/Spülflüssigkeit, **dadurch gekennzeichnet, dass** der besagte Wasch-Schritt unter Verwendung von Dämpfen der Wasch-/Spülflüssigkeit durchgeführt wird, welche durch eine Beladung des Trogs (6) mit einer Mischung von Wasser und Reinigungsmittel und das Einschalten des zweiten Widerstands (7) erzeugt werden.
- 20
- 25

#### Revendications

- 30 1. Four de cuisson électrique à convection comprenant une chambre de cuisson, une résistance de cuisson (4) et un ventilateur (5), tous deux montés sur la paroi arrière (2) de ladite chambre de cuisson et un déflecteur (21) formé par une paroi avant et des parois périphériques, monté sur ladite paroi arrière (2) afin de protéger un utilisateur contre le contact avec ladite résistance de cuisson (4) et ledit ventilateur (5), ledit déflecteur (21) étant prévu avec des parois périphériques pleines (9, 10) au niveau de ses côtés supérieur et inférieur et au moins une grille d'admission centrale (1a) dans ladite paroi avant, le déflecteur (21 ; 22) ayant une forme sensiblement octogonale qui comprend également deux paires de parois périphériques obliques (11, 12) qui sont respectivement adjacentes aux dites parois supérieure et inférieure (9, 10) et ont des ouvertures (11a, 12a) qui s'étendent sur 30-90% de la surface des dites parois obliques (11, 12), ainsi que deux parois périphériques latérales (13) qui s'étendent entre les parois obliques (11, 12), **caractérisé en ce que** le déflecteur (21) a la forme d'un octogone semi-régulier dérivé d'une rectangle ou d'un carré avec des coins biseautés, également avec les parois latérales (13) ayant des ouvertures (13a), et **en ce qu'il** comprend en outre un conduit d'alimentation en eau (3) s'étendant à partir de la paroi arrière (2) de la chambre de cuisson, un plateau (6) positionné à l'intérieur de la chambre de cuisson dans une position pour recevoir l'eau alimentée par le biais dudit conduit (3), et une
- 40
- 45
- 50
- 55

- seconde résistance (7) qui s'étend dans ledit plateau (6) de sorte que la majeure partie de ladite seconde résistance (7) est immergée dans l'eau lorsque le plateau (6) est rempli, le déflecteur (21) protégeant un utilisateur également contre le contact avec la seconde résistance (7).
2. Four selon la revendication 1, **caractérisé en ce que** dans les deux parois obliques (11) qui sont adjacentes à la paroi supérieure (9), sont formées des ouvertures (11a) qui s'étendent sur environ 80% desdites parois obliques (11).
  3. Four selon la revendication 1 ou 2, **caractérisé en ce que** dans les deux parois obliques (12) qui sont adjacentes à la paroi inférieure (10), sont formées des ouvertures (12a) qui s'étendent sur environ 40% desdites parois obliques (12).
  4. Four selon l'une quelconque des revendications 1 à 3, **caractérisé en ce que** dans les deux parois latérales (13), sont formées des ouvertures (13a) qui s'étendent sur environ 60% desdites parois latérales (13).
  5. Four selon l'une quelconque des revendications précédentes, **caractérisé en ce que** le déflecteur (21) a une hauteur réduite par rapport à la chambre de cuisson de sorte que sa paroi supérieure (9) et sa paroi inférieure (10) ne sont pas respectivement proches du plafond ni du plancher de la chambre de cuisson, et les parois périphériques du déflecteur (21) sont agencées à proximité de la résistance de cuisson (4).
  6. Four selon l'une quelconque des revendications précédentes, **caractérisé en ce que** la grille d'admission centrale (1a) s'étend plus verticalement qu'horizontalement, de préférence avec une forme elliptique ou des grilles d'admission supplémentaires sont formées au-dessus et au-dessous de ladite grille d'admission centrale (1a).
  7. Four selon l'une quelconque des revendications précédentes, **caractérisé en ce qu'il** comprend en outre un diffuseur (8) monté afin d'entourer la sortie du conduit d'alimentation en eau (3), ledit diffuseur (8) ayant une forme cylindrique avec une pluralité de gorges circumférentielles (8a) formées intérieurement, de préférence avec un pas constant, et une pluralité de trous débouchants radiaux (8b) réalisés en correspondance avec lesdites gorges circumférentielles (8a), de préférence le long de tout le périmètre du diffuseur (8).
  8. Four selon l'une quelconque des revendications précédentes, **caractérisé en ce que** le plateau (6) est intégré dans le déflecteur (21) qui a une paroi inférieure pleine (10) et a un bord arrière relevé (14) de sorte que la partie inférieure du déflecteur (21) peut contenir l'eau fournie par le conduit (3) et loger la seconde résistance (7).
  9. Four selon l'une quelconque des revendications précédentes, **caractérisé en ce que** la résistance de cuisson (4) a une forme circulaire et le ventilateur (5) est monté dans ladite forme circulaire, de préférence de manière coaxiale par rapport à cette dernière.
  10. Four selon la revendication précédente, **caractérisé en ce que** le conduit d'alimentation en eau (3) passe devant la résistance de cuisson (4) et se termine à l'intérieur de ladite forme circulaire, de préférence avec une section d'extrémité coaxiale à cette dernière.
  11. Procédé pour faire fonctionner un four selon l'une quelconque des revendications précédentes, comprenant une étape consistant à faire chauffer le four en activant la résistance de cuisson (4) jusqu'à une température de cuisson de consigne et ensuite en désactivant la résistance de cuisson (4), **caractérisé en ce que** le maintien de ladite température de cuisson est obtenu en activant et en désactivant la seconde résistance (7).
  12. Procédé pour faire fonctionner un four selon l'une quelconque des revendications 1 à 10, comprenant une étape consistant à laver la chambre de cuisson avec un fluide de lavage/rinçage, **caractérisé en ce que** ladite étape de lavage est réalisée en utilisant des vapeurs de fluide de lavage/rinçage obtenues en chargeant le plateau (6) avec un mélange d'eau et de détergeant et en activant la seconde résistance (7).

PRIOR ART

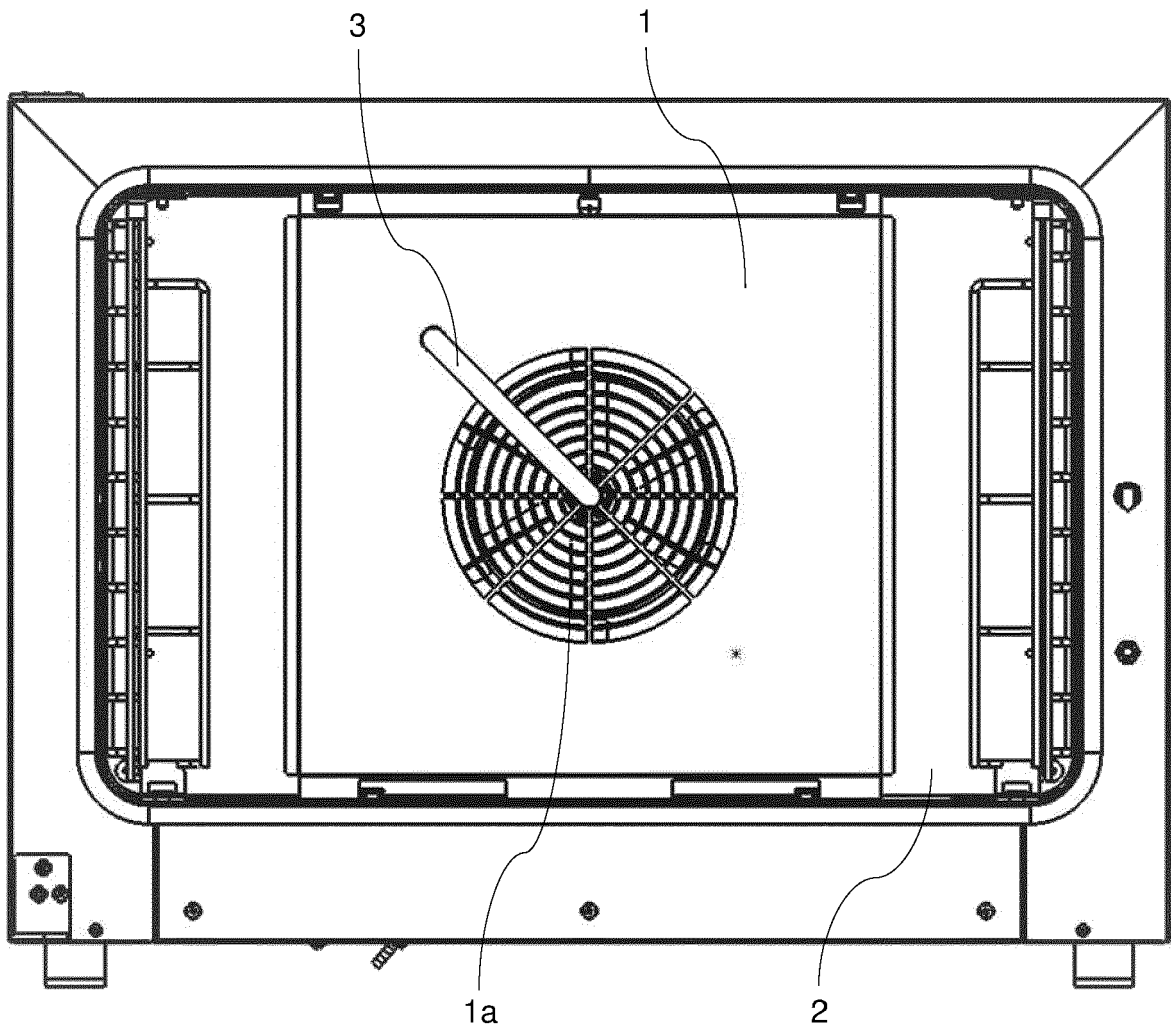

Fig.1

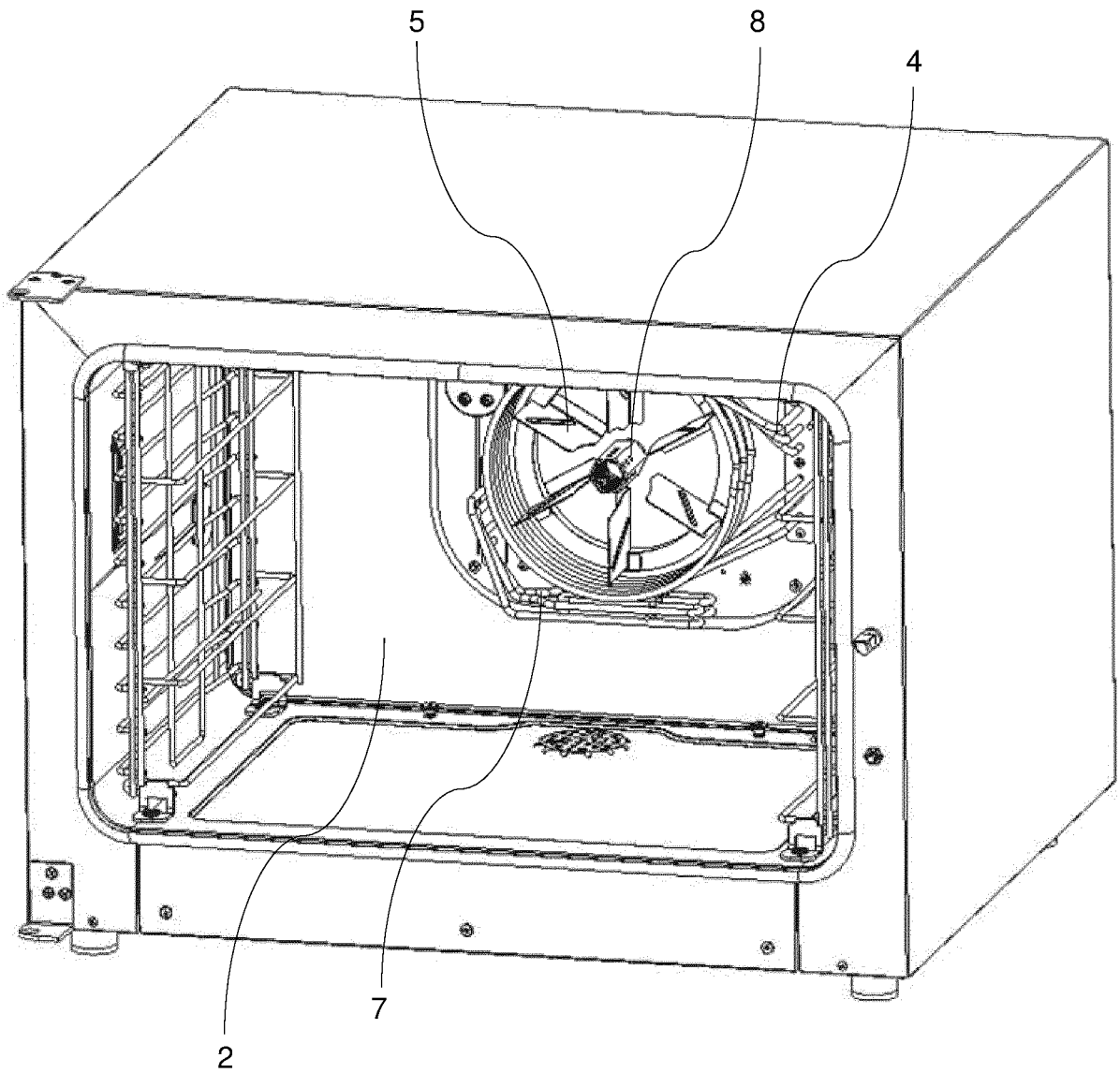

Fig.2

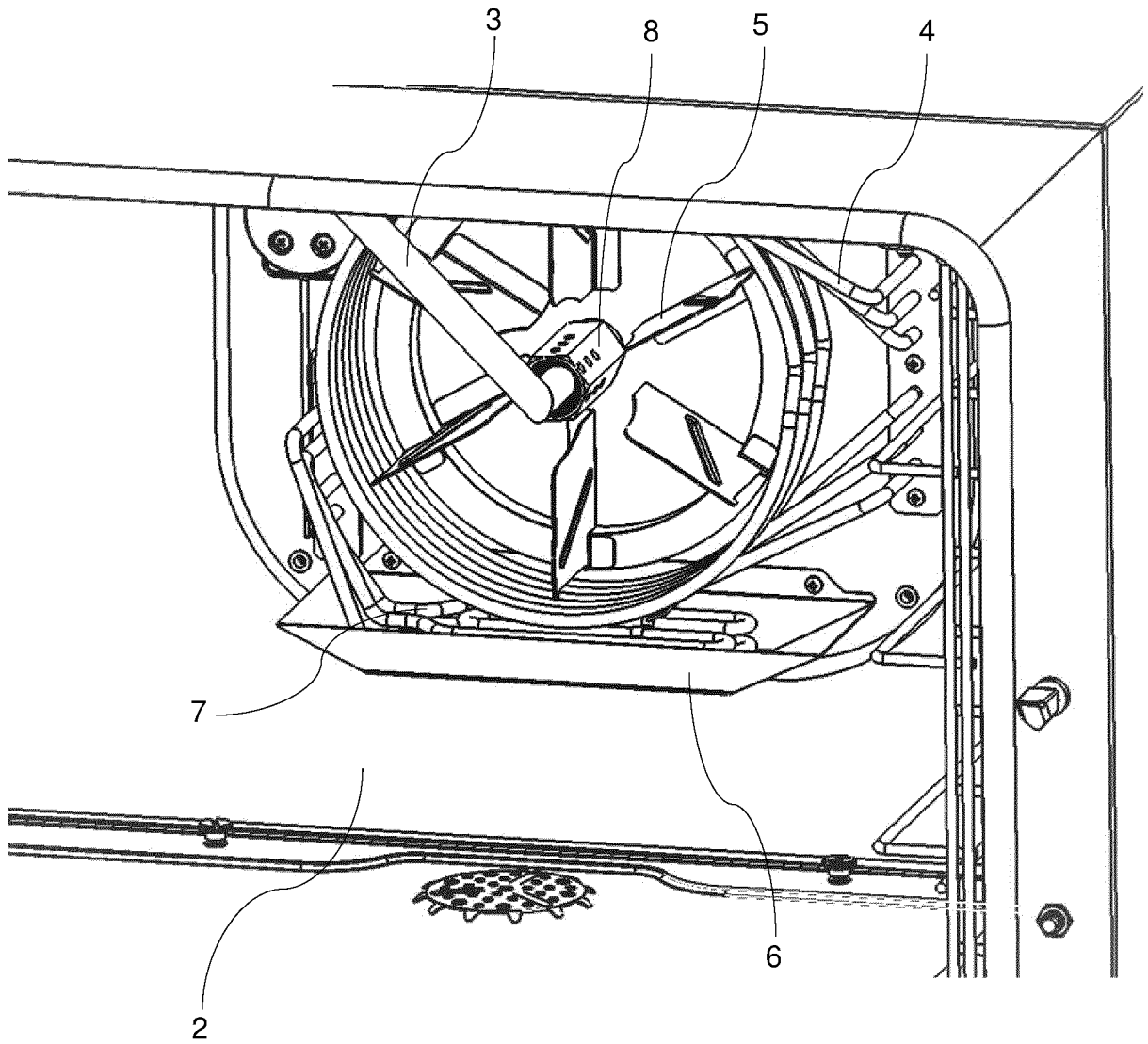
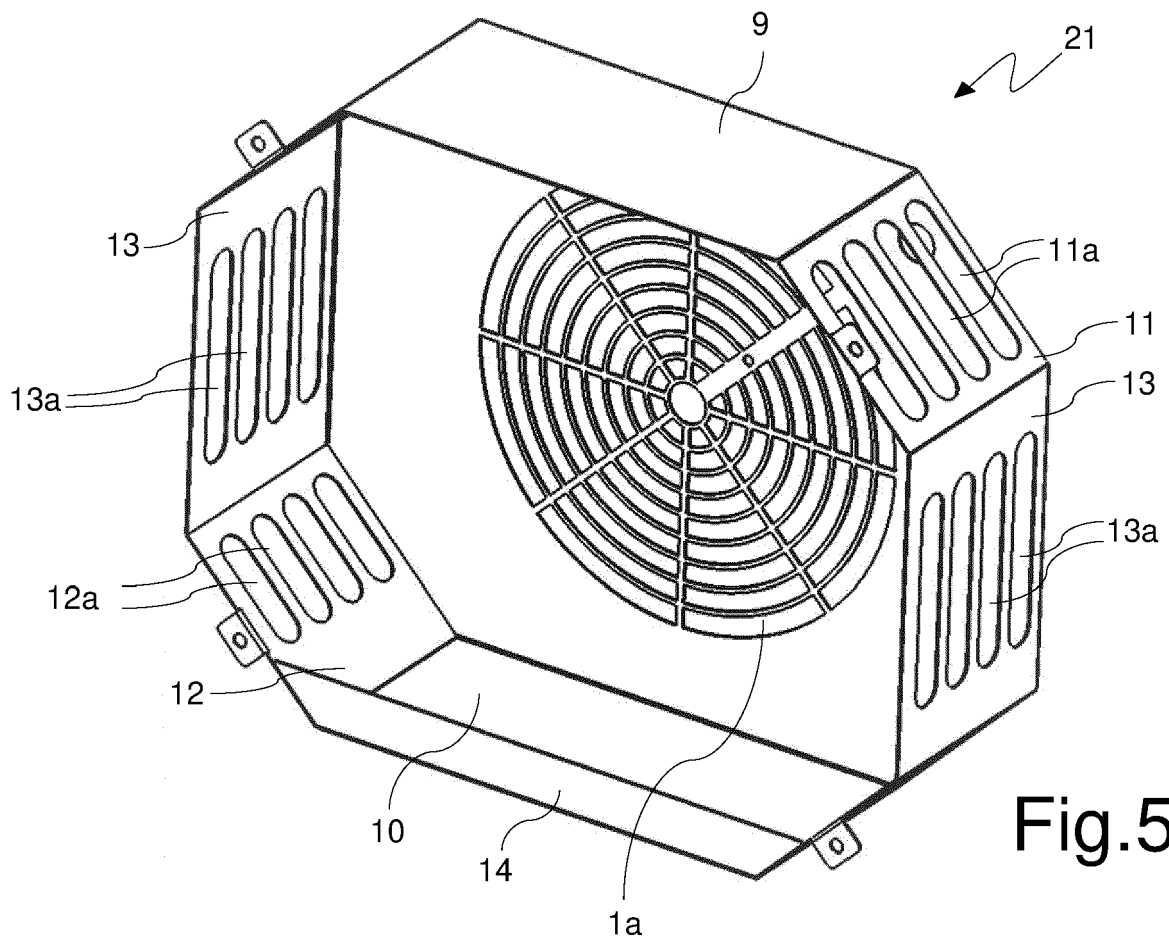
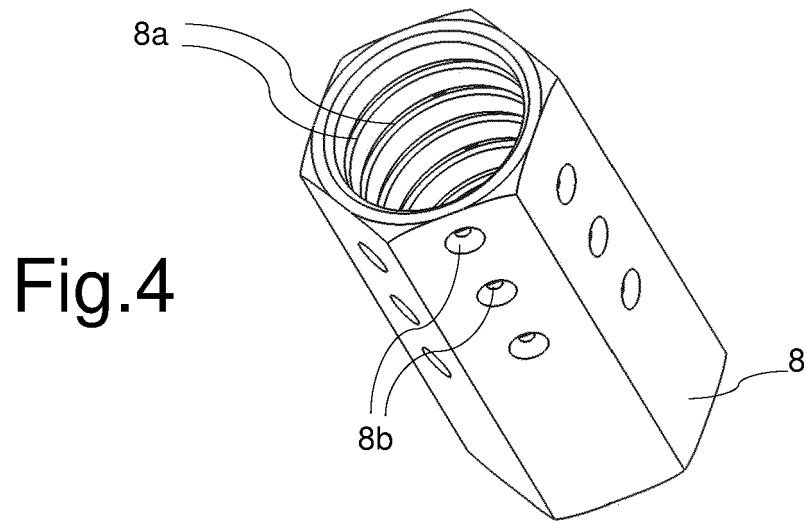

Fig.3



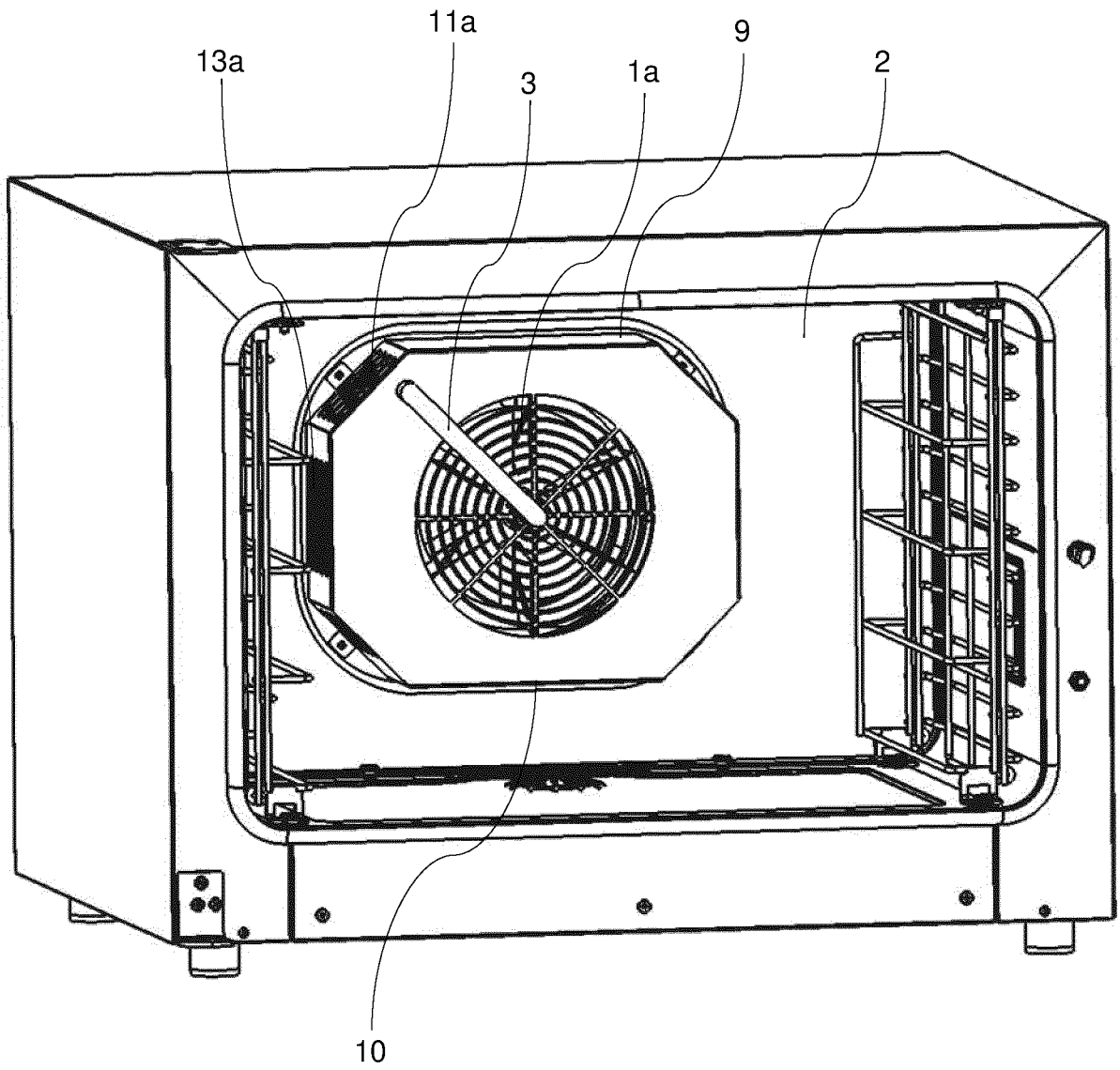

Fig.6

**REFERENCES CITED IN THE DESCRIPTION**

*This list of references cited by the applicant is for the reader's convenience only. It does not form part of the European patent document. Even though great care has been taken in compiling the references, errors or omissions cannot be excluded and the EPO disclaims all liability in this regard.*

**Patent documents cited in the description**

- EP 3399237 A [0008]
- US 20060011607 A [0010] [0014] [0015]
- EP 0401173 A2 [0011]