



(86) Date de dépôt PCT/PCT Filing Date: 2012/09/07  
 (87) Date publication PCT/PCT Publication Date: 2013/03/07  
 (45) Date de délivrance/Issue Date: 2016/02/16  
 (85) Entrée phase nationale/National Entry: 2013/01/30  
 (86) N° demande PCT/PCT Application No.: CA 2012/000839  
 (87) N° publication PCT/PCT Publication No.: 2013/033831  
 (30) Priorité/Priority: 2011/09/07 (US61/531,670)

(51) Cl.Int./Int.Cl. *A61G 13/10* (2006.01),  
*A61B 6/04* (2006.01), *A61G 1/044* (2006.01)

(72) Inventeurs/Inventors:  
MAC-THIONG, JEAN-MARC, CA;  
PARENT, STEFAN, CA;  
LABELLE, HUBERT, CA;  
DRISCOLL, MARK, CA

(73) Propriétaire/Owner:  
SPINOLOGICS INC., CA

(74) Agent: GOWLING LAFLEUR HENDERSON LLP

(54) Titre : DISPOSITIFS D'APPLICATION DE TENSION SUR L'EPAULE D'UN PATIENT ET METHODE  
D'INSTALLATION ASSOCIEE

(54) Title: DEVICES FOR APPLYING TENSION TO A PATIENT SHOULDER AND ASSOCIATED INSTALLATION  
METHOD

(57) **Abrégé/Abstract:**

A device comprises an arm cover to be positioned under the arm before being closed thereover, a shoulder strap to be positioned under the shoulder and adapted to wrap the shoulder when attached, over the shoulder, to the closed arm cover and a longitudinal strap to be fixed to the table opposite to the head. The longitudinal strap can apply tension on the shoulder strap when shortened. A method for installing a device on an immobilised patient comprising positioning an arm cover under the arm and a shoulder strap connected to the arm cover under the shoulder, closing the arm cover over the arm and attaching the shoulder strap, over the shoulder, to the closed arm cover, fixing an end of a longitudinal strap, connected to the arm cover, to the table opposite to the head and pulling on the longitudinal strap to apply tension on the shoulder strap.

**Abstract**

A device comprises an arm cover to be positioned under the arm before being closed thereover, a shoulder strap to be positioned under the shoulder and adapted to wrap the shoulder when attached, over the shoulder, to the closed arm cover and a longitudinal strap to be fixed to the table opposite to the head. The longitudinal strap can apply tension on the shoulder strap when shortened. A method for installing a device on an immobilised patient comprising positioning an arm cover under the arm and a shoulder strap connected to the arm cover under the shoulder, closing the arm cover over the arm and attaching the shoulder strap, over the shoulder, to the closed arm cover, fixing an end of a longitudinal strap, connected to the arm cover, to the table opposite to the head and pulling on the longitudinal strap to apply tension on the shoulder strap.

## DEVICES FOR APPLYING TENSION TO A PATIENT SHOULDER AND ASSOCIATED INSTALLATION METHOD

### Technical Field

[0002] The present invention relates to a medical device and, more specifically, to a  
5 medical device that facilitates imaging of the neck region.

### Background

[0003] During any procedure or imaging of the neck region, it is important to properly  
clear the neck to allow adequate access and visualization. In particular, the shoulders can  
prevent adequate access and visualization of the neck region. As a working example, during  
10 anterior and posterior surgery in the neck region, frequent imaging of the cervical anatomical  
structures is required to assess the status of a surgeon's work. This necessitates  
unobstructed imaging of the cervical spine. A patient's shoulders neutral position is in lateral  
alignment with the caudal part of the neck region and, thus, will often obstruct the view of the  
cervical spine acquired from cross-table lateral imaging.

15 [0004] The present invention provides at least a partial solution to the identified  
problem.

### Summary

[0005] The present invention aims at providing a device and an installation method of  
the device. In use, the device of the present invention provides, among others, the exemplary  
20 advantage of moving an arm cover closed over a patient's arm together with the patient  
shoulder. The present invention may further provide at least some of the following exemplary  
advantages, e.g., a device that is less error-prone, simpler and quicker to use, more  
accommodating to hospital beds, configured to allow personnel position more proximately to  
patient, installed requiring less patient position adjustment, more compatible with, and less  
25 hampered by, any matter related to the clinical/surgical environment, more easily adjustable  
intra-operatively, more secured, arranged to avoid compression of the patient's chest,  
constructed not to impede patient respiration, more adjustable to accommodate all patient  
sizes, less expensive, and more effective in accomplishing its intended use.

[0006] A first aspect of the present invention is directed to a method for installing a device on an immobilised patient lying on a table. The method comprises (a) positioning an arm cover under the patient's arm and a shoulder strap connected to the arm cover under the patient's shoulder, (b) closing the arm cover over the patient's arm and (c) attaching the shoulder strap, over the patient's shoulder, to the closed arm cover. The method also further comprises (d) fixing an end of a longitudinal strap, connected to the arm cover, to the table opposite to the patient's head and (e) pulling on the longitudinal strap to apply tension on the shoulder strap, whereby the arm cover.

[0007] For greater certainty, in the context of the present invention, an immobilized patient is meant to be construed as a patient that is unlikely to slide on the table while tension is applied on the shoulder strap. Likewise, the relative term such as "under" or "over" are used to increase clarity of the text and not to limit the use of the device.

[0008] Optionally, the arm cover may present a surface that is suitable as a hook portion of a hook and loop fastener and further comprise at least one hook portion. Likewise the shoulder strap may comprise at least one hook portion. The method may then comprise applying localised pressure over at least one of the hook portion.

[0009] Optionally, the method may comprise repeating steps (a) to (c) for the patient's second arm before performing steps (d) and (e) and repeating steps (d) and (e) for the patient's second arm. A step of installing at least one transverse strip for maintaining a maximum distance between arm covers may optionally be performed. Installing the transverse strip may further comprise installing a first transverse strip in the back of the patient at neck height between the shoulder straps, a second transverse strip at torso height between the shoulder straps and a third transverse strip at abdomen height between the arm covers.

[0010] The longitudinal strap may comprise a tension lock for maintaining the tension in the longitudinal strap. Closing the arm cover may further comprise fixing a hook portion of a base strap over the closed arm cover, wherein the base strap extends from the longitudinal strap between the tension lock and the arm cover. The method may also comprise reducing the tension in the shoulder strap through the tension lock (e.g., for shortening or lengthening the longitudinal strap thereby adjusting tension in a controlled manner).

[0011] A second aspect of the present invention is directed to a device to be installed on an immobilised patient lying on a table. The device comprises an arm cover adapted to be positioned under a patient's arm before being closed thereover, a shoulder strap adapted to be positioned under the patient's shoulder and adapted to wrap the patient's shoulder when

the shoulder strap is attached, over the patient's shoulder, to the closed arm cover and a longitudinal strap adapted to be positioned along the patient and to be fixed to the table opposite to the patient's head. The longitudinal strap is capable of applying tension on the shoulder strap when shortened.

5 [0012] The shoulder strap may be unitary with the arm cover and extend therefrom, the longitudinal strap being attached to the arm cover.

[0013] The arm cover may present a surface that is suitable as a hook portion of a hook and loop fastener and further comprises at least one hook portion. Likewise, the shoulder strap may comprises at least one hook portion of a hook and loop fastener that is  
10 adapted to attach to the arm cover.

[0014] The longitudinal strap may comprise a tension lock for maintaining the tension in the longitudinal strap.

[0015] The device may also comprise a base strap that extends from the longitudinal strap between the tension lock and the arm cover and comprises a hook portion.

15 [0016] A third aspect of the present invention is directed to a device to be installed on an immobilised patient lying on a table. The device comprises an arm covering that comprises a shoulder strip to enclose a patient's shoulder, a tension strap connected to or enclosed within the arm covering. Tightening the tension strap length between the shoulder and a fixation of the tension strap to the table exerts tension on the patient's shoulder.

20 [0017] A fourth aspect of the present invention is directed to a kit comprising a first device as described in relation to the second or third aspect of the present invention that is adapted to fit a patient's right side, a second device as described in relation to the second or third aspect of the present invention that is adapted to fit a patient's left side and at least one transverse strip adapted to maintain a maximum distance between installed arm covers upon  
25 installation. Each end of the transverse strip may further comprise a hook portion of a hook and loop fastener.

### **Brief description of the drawings**

[0018] Further features and exemplary advantages of the present invention will become apparent from the following detailed description, taken in conjunction with the  
30 appended drawings, in which:

[0019] FIG. 1 is a top view of a patient on a hospital table featuring an upper limb positioner in accordance with the teachings of the present invention;

[0020] FIG. 2 is an exploded view of an upper limb positioner in accordance with the teachings of the present invention;

5 [0021] FIG. 3 is a top view of a patient on a hospital table featuring an upper limb positioner in accordance with the teachings of the present invention;

[0022] FIG. 4 is a top view of a patient on a hospital table featuring an upper limb positioner in accordance with the teachings of the present invention;

10 [0023] FIG. 5 is a top view of a patient on a hospital table featuring an upper limb positioner in accordance with the teachings of the present invention;

[0024] FIG. 6 is an exploded view of a portion an upper limb positioner in accordance with the teachings of the present invention;

15 [0025] FIG. 7 is a top view of a patient on a hospital table featuring an upper limb positioner in accordance with the teachings of the present invention and a perspective view of an upper limb positioner in accordance with the teachings of the present invention;

[0026] FIG. 8 is a schematic representation of an exemplary kit in accordance with the teachings of the present invention;

[0027] FIG. 9 is a top view of a patient on a hospital table featuring at least some of the parts of the exemplary kit of FIG. 8;

20 [0028] FIG. 10 is an exemplary representation of installation in accordance with the teachings of the present invention; and

[0029] FIG. 11 is a flow chart of an exemplary method of installation of a device in accordance with the teachings of the present invention.

### **Detailed description**

25 [0030] The present invention relates to an upper limb positioner to urge a patient's shoulders caudally and locate their arms while supine or prone on a medical table.

[0031] Medical tables (e.g., surgical or examination tables) often do not adequately provide support of the patient's arms. A need was identified to force a patient's shoulders caudally to improve visualization of the neck region while restraining the position of the

patient's arms. Such clinical shortcomings, related to patient upper limb positioning, concern surgeries, injections, radiotherapy, imaging, etc.

[0032] Improved cervical visualization may be attempted by means of applying adhesive tape directly to the patient's shoulders, pulling the tape caudally, and fixing it to the medical table. This method, however, provides different disadvantages since it may insufficiently draw shoulders caudally, leave adhesive residue on the patient, may result in tape burn, endangers EKG leads, could lead to occluded intravenous (IVs) or arterial lines, and does not allow varying the pulling force without modifying the whole setup. In addition, in order to prepare the patient in the context of this method, an assistant needs to pull on the patient's wrist, either directly or via wrist straps, while potentially being positioned under a sterile surgical environment. Inconsistent tension on the shoulders during the radiograph is likely achieved by the present method. In addition, it is inconvenient during recurrent radiographs, may extend surgery time, may expose the assistant to radiation, may lead to injury (nerve and ligament), can block IV and arterial lines, and may jeopardize the sterile environment. Alternatively, use of different positions of the arms (e.g. swimmers position) could be used to better visualize the lower cervical spine, but the arm position is cumbersome and the visualization remains limited.

[0033] Alternatively, standard positioning of a patient's arms may be achieved by utilizing a multi-axis arm positioner that is fixed to the table supporting the patient's body. Although effective in supporting the patient's arms, this method requires significant lateral space and likely distances the personnel working position from the patient. The multi-axis arm positioner can also be displaced by the personnel during the procedure, and does not guarantee that the patient's arms will remain in their desired position. Moreover, the IVs are unsystematically found in the surgeon's working field. Alternatively, a patient's arms may be supported in their standard anatomical location (*i.e.*, adjacent to body) via a blanket type materials rolled around the arms and maintained under the patient. This method is crude, difficult to adjust, unaccommodating to patient IVs, and requires significant fiddling to obtain secured positioning. In addition, this method precludes easy access to the arms when needed.

[0034] In accordance with one embodiment of the invention, the upper limb positioner causes the patient's shoulders to be drawn caudally to allow for accurate visualization and access to the neck region and to safely locate the arms adjacent to the patient's body. The device consists of partially or totally padded straps which enclose the patient's shoulders and are attached to a segment of the hospital table. These straps span longitudinally along the patient and are mated to itself using an adjustable buckle, a hook and loop fixation, and/or

any adjustable fixation device. Caudal tension is achieved by tightening the strap through the adjustable buckle or adjustable fixation device. Conversely, loosening may be achieved through manually releasing the buckle and reducing strap tension or pulling an additional buckle, placed in series with the tension buckle, thus causing lengthening of the strap. The inner portions of the straps around the shoulders of the patient may contain a padded lining for comfort or to increase the contact surface with the shoulders. The outer portions of the straps may be covered with male VELCRO® (hooks). The outer portion of both straps may be linked transversely across the patient via female VELCRO® (loops) fasteners both ventral and dorsal to the patient to effectively secure the straps over the patient's shoulders while avoiding lateral travel, an action inherently caused by the increased slope angle from the shoulders to the axilla occurring when placed under caudal tension. Alternatively, the transverse link may be achieved via a strap(s), including an adjustable buckle or connection, which may be moved cranially or caudally along the longitudinal straps. The patient's thorax, abdomen, and pelvis are maintained free to allow easy access if needed.

[0035] The adjoining upper limb harness is united to the shoulder straps by a plurality of female VELCRO® found on the outer material of the harness. The female VELCRO® strips found on the harness are configured to allow the arm position to be adjusted as desired. An upper limb harness failsafe cross-link strap may also be provided to offer a solid custom fixation of both upper limb harnesses to prevent lateral traveling of the arms. This optional connecting harness strap contains an adjustable buckle for quick and easy installation and to allow for additional adjustments of the medial/lateral location of the arms. The superior portion of the upper limb harness contains a void to allow IV, arterial and monitoring connections to pass freely. The inferior portion of the upper limb harness contains an adjoining male and female VELCRO® fixture, free from the shoulder straps, to allow easy opening of the harness to perform verifications and/or modifications to the IV, arterial and monitoring devices, and to the arm position. All attachments and connections of the upper limb positioner may be achieved via any adjoining methods such as snaps, buttons, zippers, hooks, ties, etc., or any combination thereof.

[0036] In accordance with another embodiment of the invention, the upper limb positioner causes the patient's shoulders to be drawn caudally to allow for accurate visualization and access to the neck region, and to comfortably locate the arms adjacent to the patient body. The device consists of upper limb coverings that open longitudinally along its length, straps, buckles, and hoop and loop fixations. The upper limb coverings pass over the patient's shoulders and conceal the majority of the patient's upper limbs from shoulders to hands. The opening is found medially and allows for the well-ordered inclusion or

exclusion of the IV, arterial and monitoring devices within its construct. Closure of the upper limb covering is achieved via hoop and loop type or any other fixations. The coverings of both arms are joined transversely via another hoop and loop or any fixation method which, as in the other embodiment, may be installed at the desired location of the surgeon to avoid breast, abdominal, and/or genital compression and impediment of patient respiration. This transverse fixation also allows for arm position to be varied distal, proximal, palmar, and/or dorsal as desired. Connected to or enclosed within the arm coverings are tension straps that transmit caudal forces to the patient's shoulders. This tension force is achieved by tightening the strap length between the shoulder and the fixation to the hospital bed. Conversely, loosening may be achieved through manually releasing the buckle and reducing strap tension or pulling an additional buckle, placed in series with the tension buckle, thus causing lengthening of the strap.

[0037] In accordance with yet another embodiment of the invention, the upper limb positioner causes the patient's shoulders to be drawn caudally to allow for accurate visualization and access to the neck region and to comfortably locate the arms adjacent to the patient body. The device consists of an upper body covering, straps, and buckles. The upper body covering encloses the patient's upper limbs and torso in a manner that maintains the upper limbs adjacent to the patient's body. This upper body covering is placed under and then folded over the patient. Straps, connected to the bottom to or included within the covering are fixed to the hospital table. Caudal forces are transferred to the shoulders by shortening the strap length between the patient and the hospital table by means of an adjustable buckle or webbing clip. Conversely, loosening may be achieved through manually releasing the buckle and reducing strap tension or pulling an additional buckle, placed in series with the tension buckle, thus causing lengthening of the strap.

[0038] In accordance with yet another embodiment of the invention, the upper limb positioner causes the patient's shoulders to be drawn caudally to allow for accurate visualization and access to the neck region and to comfortably locate the arms adjacent to the patient body. The device consists of shoulder strips combined with arm coverings, buckles, and straps. The shoulder strips and arm coverings are unitary in construction and made from a padded material with loop characteristics (hook sensitive) such as but not limited to Veltex® or Velfoam®. The shoulder strips enclose the patient's shoulders. The connected arm coverings enclosed the patient's arms. Both the shoulder strips and arm coverings are interconnected through a variety of fixtures. Caudal forces are transferred to the shoulders by shortening the strap length between the patient and the hospital table by means of an adjustable buckle or webbing clip. Conversely, loosening may be achieved

through manually releasing the buckle and reducing strap tension or pulling an additional buckle, placed in series with the tension buckle, thus causing lengthening of the strap.

[0039] In accordance with yet another embodiment of the invention, the upper limb positioner causes the patient's shoulders to be drawn caudally to allow for accurate visualization and access to the neck region and to comfortably locate the arms adjacent to the patient body. A unitary or combining receiving structure(s) is placed under or adjacent to the patient and encloses their shoulders and arms. This structure is open ended and allows personnel to visualize the entire upper body of the patient while the upper limb perimeter is closed for custom positioning. The perimeter upper limb positioner is adjustable to fit all patient sizes and to allow for upper limb position to be adjusted and maintained as desired. The upper limb positioner is maintained to the hospital table via a fixation or weight of the patient. As an example, in this embodiment, the upper limb positioner may be constructed in two separate pieces longitudinally split along its center line. The underside, that is to be in contact with the hospital table, may be a non-skid surface or a one-way one skid surface. This would allow for the displacement of the upper limb positioner and adjacent upper limbs to the desired location while the patient's weight provides the normal force for friction between the underside of the upper limb positioner and the hospital table to securely maintain their newly chosen position. Alternatively, if fixed to the hospital table, the position upper limb positioner and adjacent upper limbs may be adjusted via adjustable cranks. Alternatively, the upper limb positioner may be made from a series of connecting pieces that may be interlocked with each other via one way locking mechanism.

[0040] Reference is now made to the drawings, in which FIG. 1 and FIG. 2 show a patient lying supine on a hospital bed **10** and using an upper arm positioner in accordance with the teachings of the present invention. One end of the straps **14** enclose the patient's upper limbs, with the partially padded section of the straps **15** placed over the shoulders, while the other end fixes to the hospital table **20** via a simple enclosure fixation. Transverse linking straps **16**, made from female VELCRO®, are positioned at the discretion of the operator to link both straps. The positions of the transverse linking straps are made to accommodate any patient while avoiding breast and chest compressions. The adjoining upper limb harnesses **13** are combined to the straps **14** by means of female VELCRO® **11** over the shoulders and a number of other locations on the straps **14** to the effectively secure the upper limb harness **13**, thus forming the upper limb positioner. The inferior portion of the upper limb harness, near the patients hands, may be joined to itself also using hook and loop methods for an inter-linking fixation **17**. This, sub-fixation allows the patient's arms and corresponding IVs to be easily verified and adjusted as needed. A failsafe crosslink **18** joins

both upper limb harnesses for assured positioning of the arms via an adjustable buckle. At any moment during the installation of the upper limb positioner or intra-operatively, the shoulders may be forced caudally by reducing the length of the strap 14 between the patient's shoulders and the fixation to the hospital bed 20 via the adjustable buckle 19. To permit easy intra-operative adjustments, a pull strap 22 is offered that extends below the surgical sterile environment. As needed, this pull strap may be accessed and pulled to additionally urge the patient's shoulders caudally.

[0041] In reference to FIG. 3 the patient is lying supine on a hospital bed 10 fitted with another embodiment of the applicants' invention, the upper arm positioner. One end of the strap 24 is fixed to or may be included within the upper limb harness 23 while the other end fixes to the hospital table 28 via a simple enclosure fixation. Transverse linking straps 25, made from female VELCRO®, are positioned at the discretion of the operator to link both upper limb harnesses. The positions of the transverse linking straps are made to accommodate any patient while avoiding breast and chest compressions. As in the previous embodiment, the inferior portion of the upper limb harness, near the patients hands, may be joined to itself also using hook and loop methods for an inter-linking fixation. This, sub-fixation allows the patient's arms and corresponding IVs to be easily verified and adjusted as needed. A failsafe crosslink 26 joins both upper limb harnesses for assured positioning of the arms via an adjustable buckle. At any moment during the installation of the upper limb positioner or intra-operatively, the shoulders may be forced caudally by reducing the length of the strap 24 between the patient's shoulders and the fixation to the hospital bed 28 via the adjustable buckle 27.

[0042] In reference to FIG. 4 the patient is lying supine on a hospital bed 10 fitted with yet another embodiment of the applicants' invention, the upper arm positioner. One end of the strap 30 is fixed to or may be included within the upper body harness 29 while the other end fixes to the hospital table 32 via a simple enclosure fixation. The upper body harness encloses the patient's upper body. This is achieved by laying the patient on the inferior portion of the upper body harness and then folding the upper portion over the patient. The lower and upper portions of the harness are combined using a plurality of hook and loop fixations found at the shoulder level and along its connecting portions. At any moment during the installation of the upper limb positioner or intra-operatively, the shoulders may be forced caudally by reducing the length of the strap 29 between the patient's shoulders and the fixation to the hospital bed 32 via the adjustable buckle 31.

[0043] In reference to FIG. 5 and FIG. 6 the patient is lying supine on a hospital bed 10 fitted with yet another embodiment of the applicants' invention, the upper arm positioner.

First, the shoulder strips **33** are positioned over the patient's shoulders and connected to itself via a fixation such as a buckle **39**. Second, the arm coverings **34** are anteriorly folded over the patient's arms and connected to the shoulder strips **33** via a hook and loop fixation(s) **41**. A transverse safety connection **38** of the arm coverings is provided and consists of a strap with a buckle(s) connection. This connection secures the arm position, allows fine tuning of arm position, and grants easy access to the patient's IVs and arterial lines. Transverse linking strap(s) **37**, possibly made from a combination of Veltex® and Velcro®, are positioned at the discretion of the operator to link both shoulder strips and avoid lateral migration of the upper limb positioner. The positions of the transverse linking straps are made to accommodate any patient while avoiding breast and chest compressions. At any moment during the installation of the upper limb positioner or intra-operatively, the shoulders may be forced caudally by reducing the length of the strap between the patient's shoulders and the fixation to the hospital bed **40** via the adjustable buckle **36**. Conversely, loosening may be achieved through manually releasing the buckle and reducing strap tension or pulling an additional buckle **35**, placed in series with the tension buckle, thus causing lengthening of the strap.

[0044] In reference to FIG. 7, the patient is lying supine on a hospital bed **10** fitted with yet another embodiment of the applicants' invention, the upper arm positioner. The patient's upper limbs, from shoulders to hands, are enclosed and supported by the upper limb positioner **42**. The upper limb positioner **42** may be placed before or after the patient is laid on the hospital table. Once installed, position of the patient's upper limbs may be moved and maintained as desired by displacing the position of the upper limb positioner. In turn, the upper limb positioner's location is secured via friction, fixations to the hospital bed, and/or inter-locking mechanisms between respective pieces.

[0045] FIG. 8 shows an exemplary kit **800** in accordance with the teachings of the present invention. The kit **800** comprises a first device **810** adapted to fit under a patient's left arm. The first device **810** comprises an arm cover **8110** adapted to be positioned under a patient's arm before being closed thereover. The first device **810** also comprises a shoulder strap **8120** adapted to be positioned under the patient's shoulder. The shoulder strap **8120** is further adapted to wrap the patient's shoulder when the shoulder strap is attached, over the patient's shoulder, to the closed arm cover **8110**. The first device **810** further comprises a longitudinal strap **8130** adapted to be positioned along the patient and to be fixed to the table opposite to the patient's head. The longitudinal strap **8130** is capable of applying tension on the shoulder strap when shortened. In the exemplary kit **800**, the first device **810** presents, as an example, the shoulder strap **8120** being unitary with the arm cover **8110** and extending

therefrom and further presents the longitudinal strap 8130 being attached to the arm cover 8110.

[0046] The arm cover 8110 may further present a surface that is suitable as a hook portion of a hook and loop fastener and further comprise at least one hook portion 8112. Likewise, the shoulder strap 8120 may comprise at least one hook portion 8122 of a hook and loop fastener. The longitudinal strap 8130 may also comprise a tension lock 8132 for maintaining the tension in the longitudinal strap 8130. A base strap 8134 may also further extend from the longitudinal strap 8130 between the tension lock 8132 and the arm cover 8110 and comprise a hook portion 8136.

[0047] As skilled reader will appreciate, the end of the longitudinal strap 8130 that is not attached or otherwise connected to the arm cover 8110 is meant to be pulled, once the device is properly installed, to increase tension in the longitudinal strap 8130 which, in turn, increases tension applied to the patient's shoulder. Skilled person will notice that the pulled end of the longitudinal strap 8130 that extends from the tension lock 8132 is thereby unlikely to extend in an eventual sterile field (e.g., required during a surgery). The arrangement of the device 810 makes it possible to adjust the tension in the longitudinal strap 8130 while limiting the risk of jeopardizing the eventual sterile field.

[0048] The kit 800 also comprises a second device 820 adapted to fit under a patient's right arm. In the exemplary kit 800, both devices 810 and 820 have identical mirrored features. Skilled readers will understand that other kits could be provided with different devices adapted to fit different context of use.

[0049] The kit 800 also comprises at least one transverse strip (832, 834, 836) adapted to maintain a maximum distance between the arm covers of the first device 810 and second device 820, once installed. Each end of each transverse strip (832, 834, 836) may also comprise a hook portion of a hook and loop fastener.

[0050] FIG. 9 shows a top view of the exemplary kit 800 once installed on a patient. In the example of FIG. 9, transverse strips 832 and 836 are visible while transverse strip would be installed under the patient.

[0051] Reference is now made concurrently to FIG. 10 and FIG. 11. FIG. 10 shows a top view of a patient during installation of the first device 810 of the exemplary kit 800. Fig 11 shows a flow chart of an exemplary installation method 1100 of the first device 810. The patient is immobilized (not shown) and lying on a table.

[0052] The method comprises positioning 1110 an arm cover 8110 under the patient's arm and a shoulder strap 8120 connected to the arm cover 8110 under the patient's shoulder. The method then follows with closing 1120 the arm cover over the patient's arm and attaching 1130 the shoulder strap 8120, over the patient's shoulder, to the closed arm cover 8110. Thereafter, an end (not shown on FIG. 10) of a longitudinal strap 8130, connected to the arm cover 8110, is fixed 1140 to the table opposite to the patient's head. The method of installation follows with pulling 1150 on the longitudinal strap 8130 to apply tension on the shoulder strap 8120. As can be appreciated, any movement of the patient's shoulder along the tension will also cause an equivalent movement in the arm cover 8110.

10 [0053] Closing 1120 the arm cover 8110 may also further comprise fixing the hook portion 8136 of the base strap 8134 over the closed arm cover 8130. Reducing (not shown) the tension in the shoulder strap 8120 may be achieved through the tension lock 8132 (if present).

[0054] In the most common expected use of the present invention, the second device 820 of the exemplary kit 800 is installed at least before performing the step 1150 of pulling on the longitudinal strap 8130, and maybe before the step 1140 of fixing the longitudinal strap 8130 to the table. Steps 1110 to 1140 are repeated for the patient's second arm. The method may also comprise installing (not shown) at least one transverse strip (832, 834, 836) for maintaining a maximum distance between arm covers. For instance, a first transverse strip 834 may be installed in the back of the patient at neck height between the shoulder straps, a second transverse strip 832 may be installed at torso height between the shoulder straps and a third transverse strip 836 may be installed at abdomen height between the arm covers.

[0055] The method 1100 may also further comprise applying (now shown) localised pressure over at least some of the hook portions of the first device 810.

25 [0056] In the course of the above described embodiments, a number of alternatives have been identified and others may well occur to those skilled in the art without departing from the field of the invention. Thus, various combinations, sub-combinations, and sundry adaptations are maintained under the principles of the provided invention.

[0057] A method is generally conceived to be a self-consistent sequence of steps leading to a desired result. Skilled persons will readily understand how the steps of the exemplary methods described herein could be rearranged without affecting the desired result. Exemplary embodiments have been described to demonstrate the use, principles, and function of the invention disclosed herein. These descriptions and illustrations are non-limiting exemplary embodiments and no limitation to the scope of the invention is thereby

intended. Any alteration or modification to the device or alternative application of the invention principles are contemplated to normally occur by those with ordinary skill in the art to which the invention relates. Likewise, the description of the present invention has been presented for purposes of illustration but is not intended to be exhaustive or limited to the disclosed embodiments. Many modifications and variations will be apparent to those of ordinary skill in the art. The embodiments were chosen to explain the principles of the invention and its practical applications and to enable others of ordinary skill in the art to understand the invention in order to implement various embodiments with various modifications as might be suited to other contemplated uses.

10

**Claims**

1. A method for installing a device on an immobilised patient lying on a table, the method comprising:
- (a) positioning an arm cover between the patient's arm and the table;
- 5 (b) positioning a shoulder strap connected to the arm cover under the patient's shoulder;
- (c) closing the arm cover over the patient's arm;
- (d) attaching the shoulder strap, over the patient's shoulder, to the closed arm cover;
- 10 (e) fixing an end of a longitudinal strap to the table opposite to the patient's head near the patient's legs, wherein the longitudinal strap is connected to the arm cover; and
- (f) pulling on the longitudinal strap to apply tension on the shoulder strap via the arm cover.
- 15 2. The method of claim 1, wherein the arm cover presents a surface that is suitable as a hook portion of a hook and loop fastener and further comprises at least one hook portion, wherein closing the arm cover further comprises applying localised pressure over the at least one of the hook portion.
3. The method of claim 1 or claim 2, wherein the shoulder strap comprises at least one  
20 hook portion of a hook and loop fastener and wherein attaching the shoulder strap to the closed arm cover further comprises applying localised pressure over the hook portion of the shoulder strap.
4. The method of claim 1 further comprising repeating steps (a) to (d) for the patient's second arm before performing steps (e) and (f) and repeating steps (e) and (f) for the  
25 patient's second arm, wherein the method further comprises, before performing step (f), installing at least one transverse strip for maintaining a distance that can only decrease between the arm covers.
5. The method of claim 2 further comprising repeating steps (a) to (d) for the patient's second arm before performing steps (c) and (f) and repeating steps (e) and (f) for the  
30 patient's second arm, wherein the method further comprises, before performing step

- (f), installing at least one transverse strip for maintaining a distance that can only decrease between the arm covers.
6. The method of claim 5, wherein each end of the at least one transverse strip comprise a hook portion of a hook and loop fastener and wherein installing the transverse strip further comprises applying localised pressure over the hook portion of the transverse strip.
7. The method of claim 6, wherein the shoulder strap presents a surface that is suitable as a hook portion of a hook and loop fastener and wherein installing the at least one transverse strip comprises installing a first transverse strip in the back of the patient at neck height between the shoulder straps, a second transverse strip at torso height between the shoulder straps and a third transverse strip at abdomen height between the arm covers.
8. The method of any one of claims 1 to 7, wherein the longitudinal strap comprises a tension lock for maintaining the tension in the longitudinal strap.
9. The method of claim 8, wherein closing the arm cover further comprises fixing a hook portion of a base strap over the closed arm cover, wherein the base strap extends from the longitudinal strap between the tension lock and the arm cover.
10. The method of claim 8 or claim 9 further reducing the tension in the shoulder strap through the tension lock.
11. The method of any one of claims 8 to 10, wherein pulling the longitudinal strap is performed by pulling on the end of the longitudinal strap that extends from the tension lock and is not fixed to the table.
12. A device to be installed on an immobilised patient lying on a table, the device comprising:
- (a) an arm cover adapted to be positioned between a patient's arm and the table before being closed over the patient's arm;
- (b) a shoulder strap adapted to be positioned under the patient's shoulder and adapted to wrap the patient's shoulder when the shoulder strap is attached, over the patient's shoulder, to the closed arm cover; and

- (c) a longitudinal strap adapted to be positioned along the patient and to be fixed to the table opposite to the patient's head, wherein the longitudinal strap is capable of applying tension on the shoulder strap, via the arm cover, when shortened.
- 5 13. The device of claim 12, wherein the shoulder strap is unitary with the arm cover and extends therefrom, the longitudinal strap being attached to the arm cover.
14. The device of claim 12 or claim 13, wherein the arm cover presents a surface that is suitable as a hook portion of a hook and loop fastener and further comprises at least one hook portion.
- 10 15. The device of any one of claims 12 to 14, wherein the shoulder strap comprises at least one hook portion of a hook and loop fastener that is adapted to attach to the arm cover.
16. The device of any one of claims 12 to 15, wherein the longitudinal strap comprises a tension lock for maintaining the tension in the longitudinal strap.
- 15 17. The device of claim 16, wherein the end of the longitudinal strap that extends from the tension lock, and is not adapted to be fixed to the table, is adapted to be pulled to apply tension in the longitudinal strap.
18. The device of claim 16 or claim 17, further comprising a base strap that extends from the longitudinal strap between the tension lock and the arm cover and comprises a  
20 hook portion.
19. A kit comprising:
- (a) a device as claimed in anyone of claims 12 to 18 adapted to fit a patient's right side;
- (b) a device as claimed in anyone of claims 12 to 18 adapted to fit a patient's left  
25 side; and
- (c) at least one transverse strip adapted to maintain a distance that can only decrease between installed arm covers.
20. The kit of claim 19, wherein each end of the at least one transverse strip comprise a hook portion of a hook and loop fastener.

21. A device to be installed on an immobilised patient lying on a table, the device comprising:
- (a) an arm covering that comprises a shoulder strap to enclose a patient's shoulder;
  - 5 (b) a tension strap connected to or enclosed within the arm covering, wherein tightening the tension strap length between the shoulder and a fixation of the tension strap to the table exerts tension on the patient's shoulder.
22. The device of claim 21, wherein the shoulder strip is unitary with the arm covering and extends therefrom, the tension strap being connected to or enclosed within the  
10 arm covering.
23. The device of claim 21 or claim 22, wherein the arm cover presents a surface that is suitable as a hook portion of a hook and loop fastener and further comprises at least one hook portion.
24. The device of any one of claims 21 to 23, wherein the shoulder strap comprises at  
15 least one hook portion of a hook and loop fastener that is adapted to attach to the arm cover.
25. The device of any one of claims 21 to 24, wherein the tension strap comprises a tension lock for maintaining the tension in the tension strap.
26. The device of claim 25, wherein the end of the tension strap that extends from the  
20 tension lock, and is not adapted to be fixed to the table, is adapted to be pulled to apply tension in the tension strap.
27. The device of claim 25 or claim 26, further comprising a base strap that extends from the tension strap between the tension lock and the arm cover and comprises a hook portion.

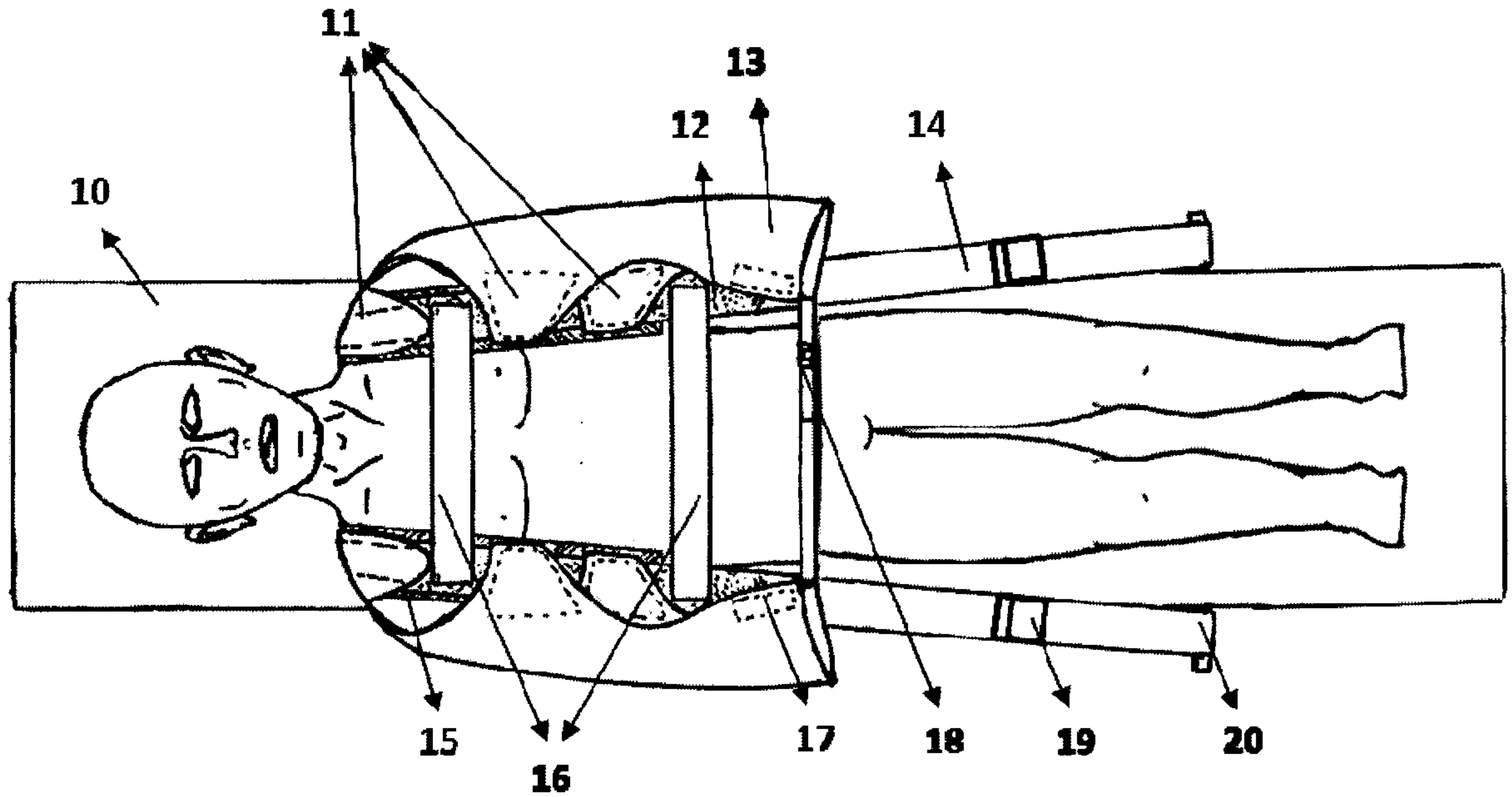

FIG. 1

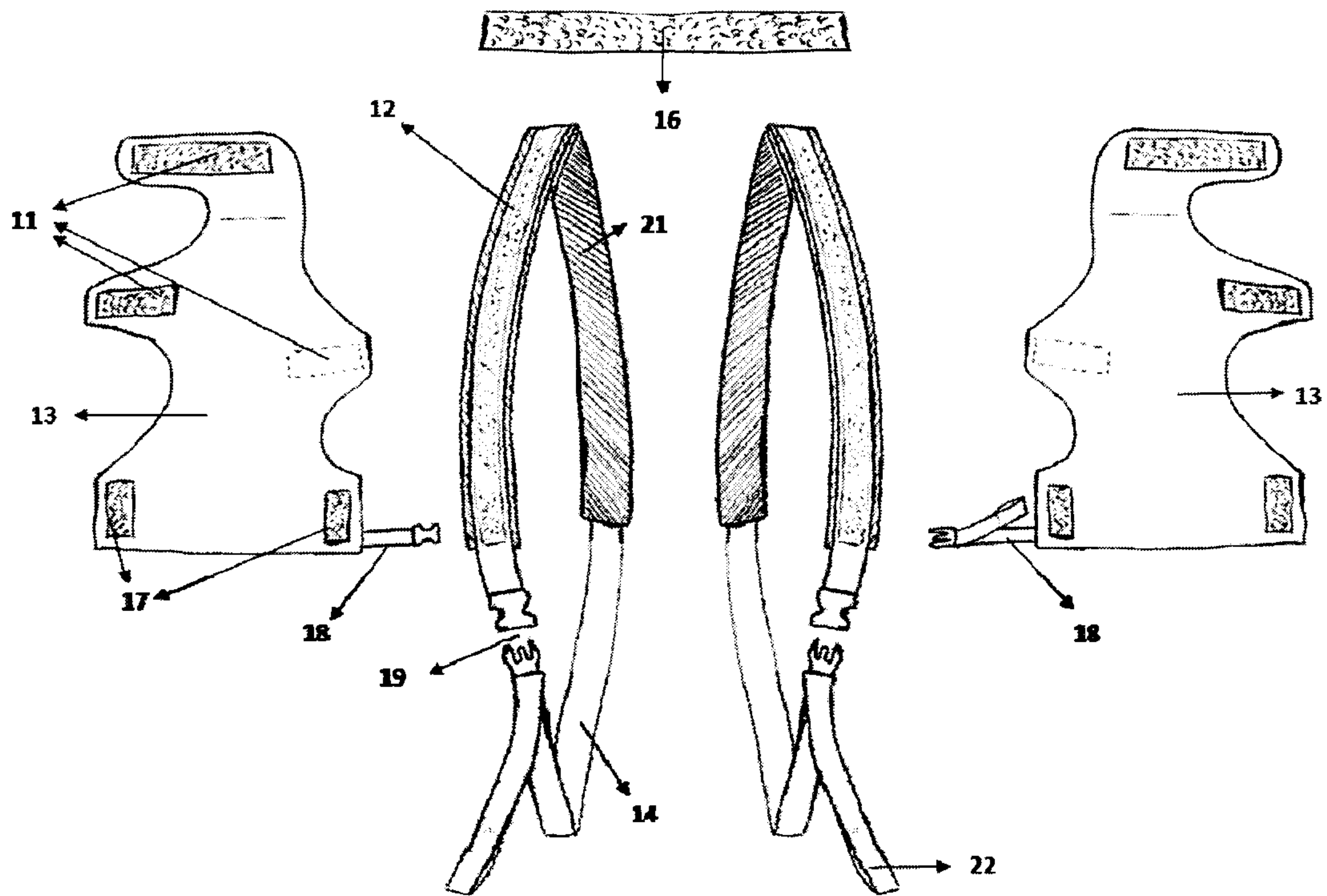

FIG. 2

2 / 7

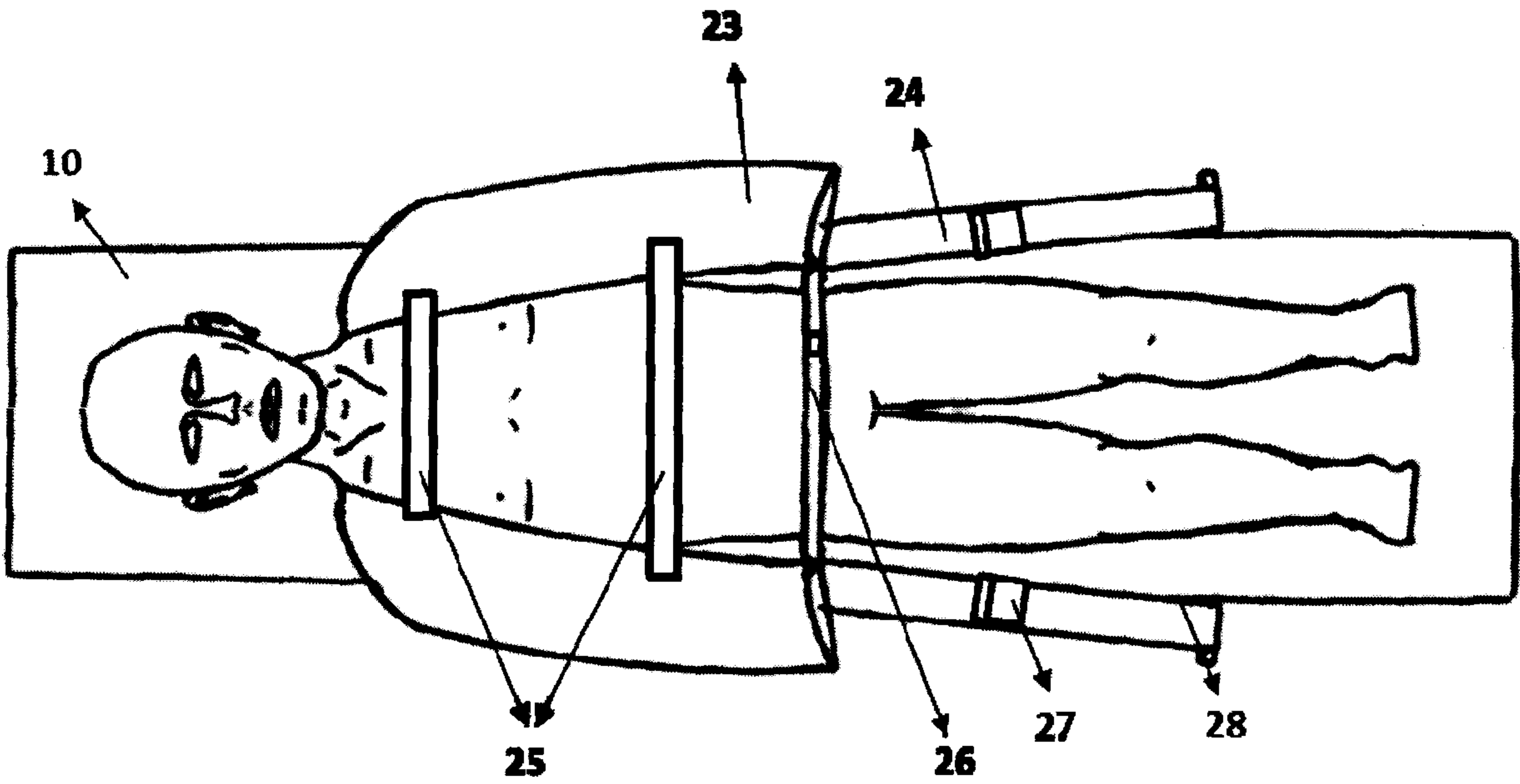

FIG. 3

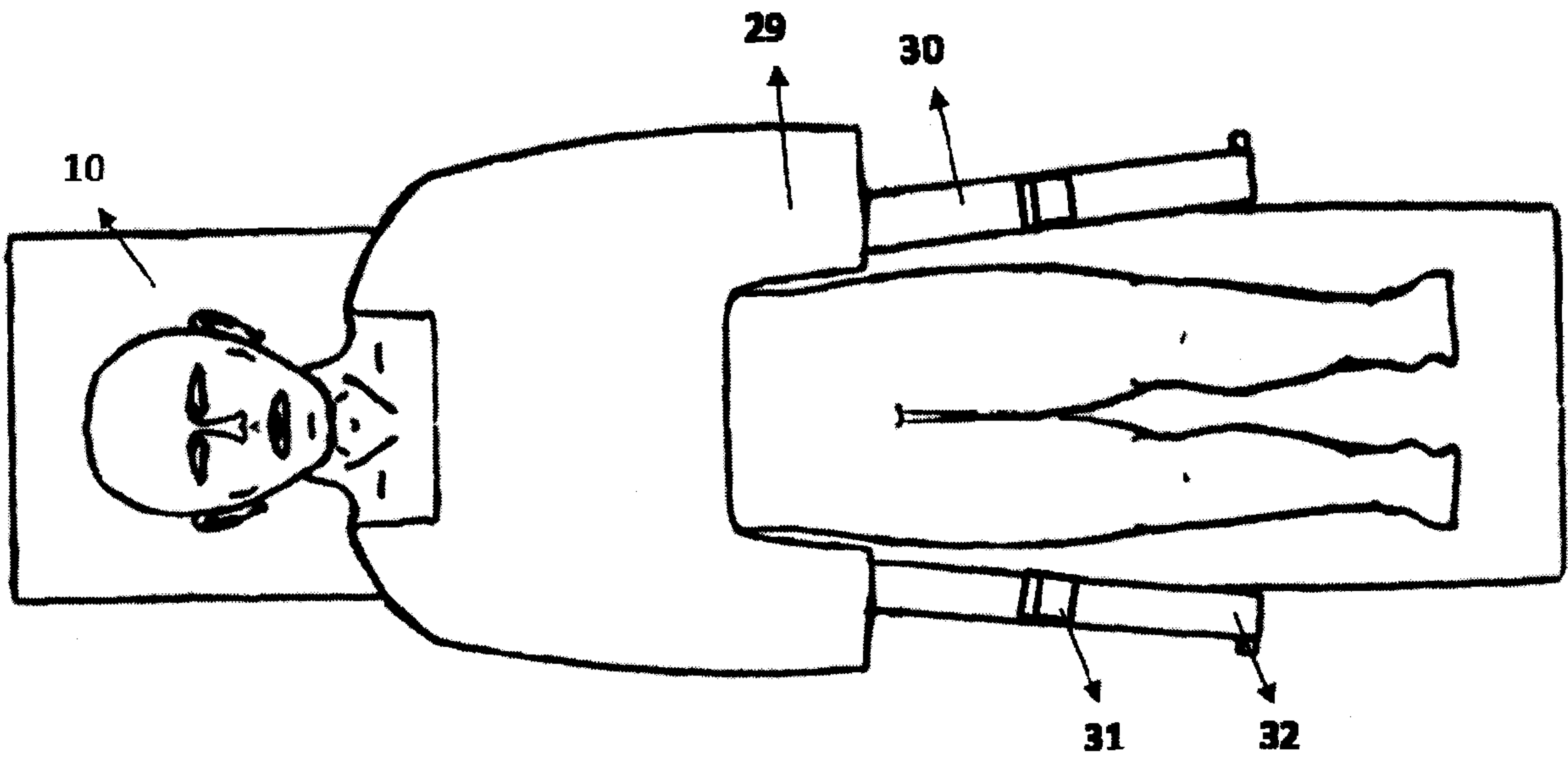

FIG. 4

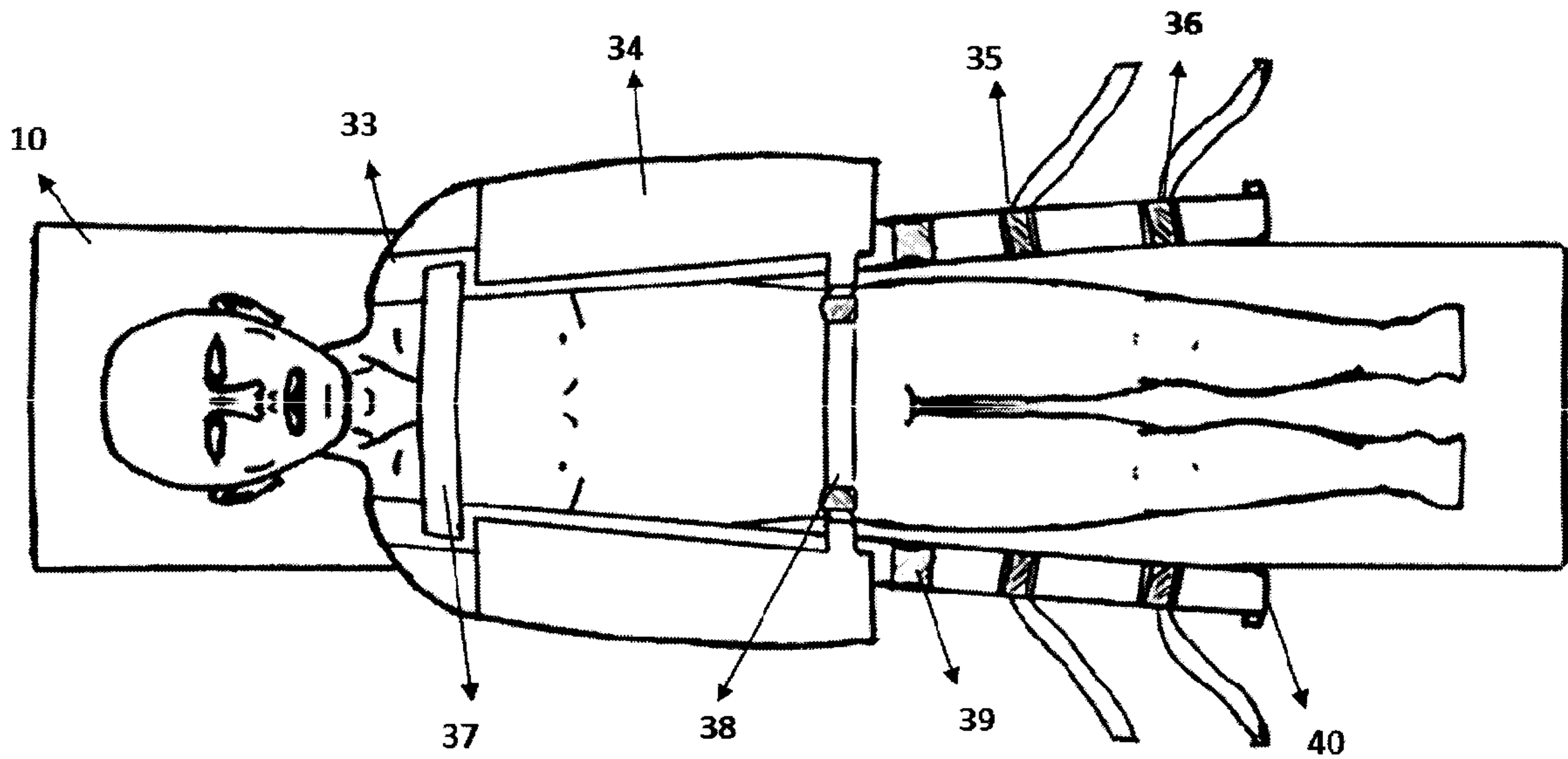

FIG. 5

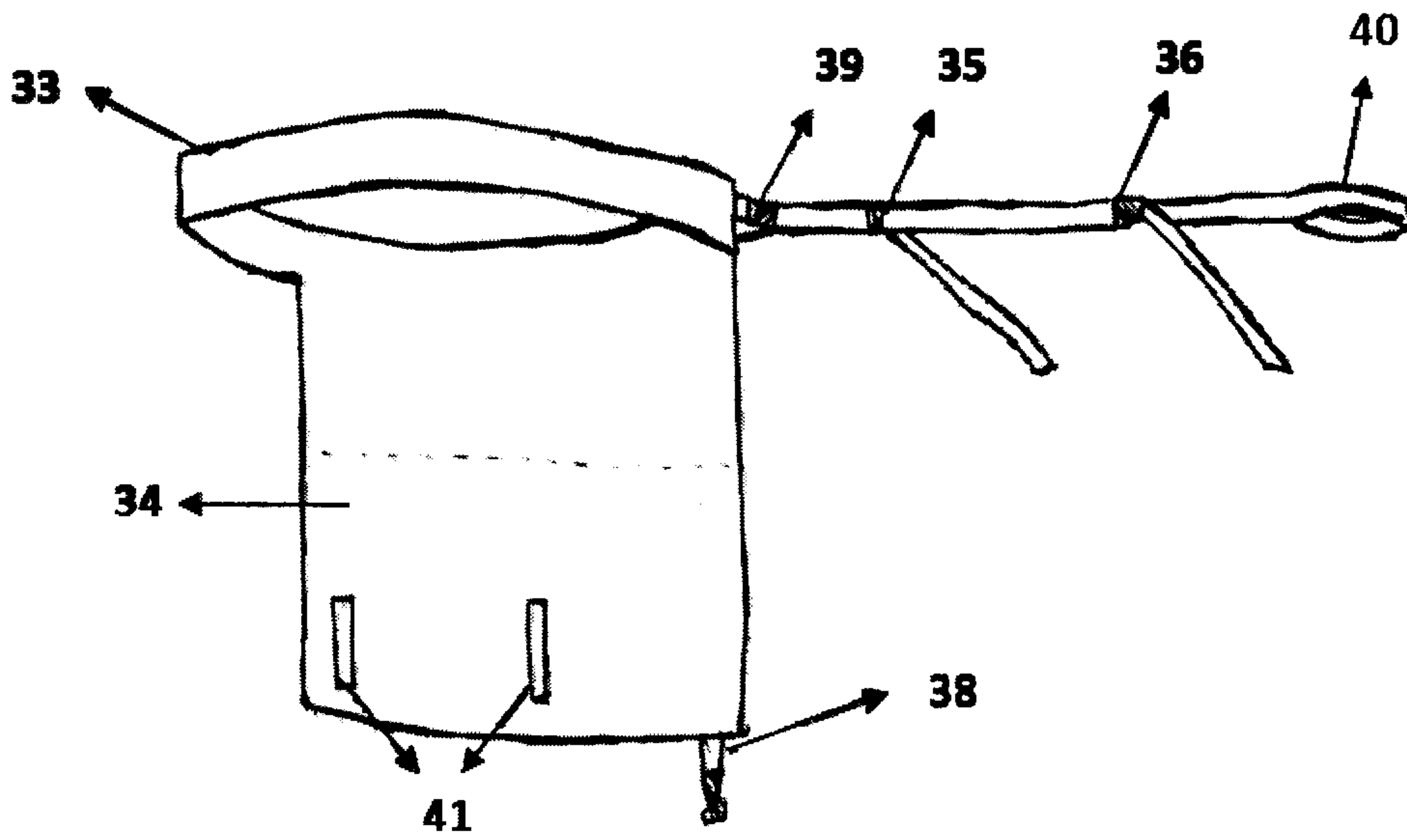

FIG. 6

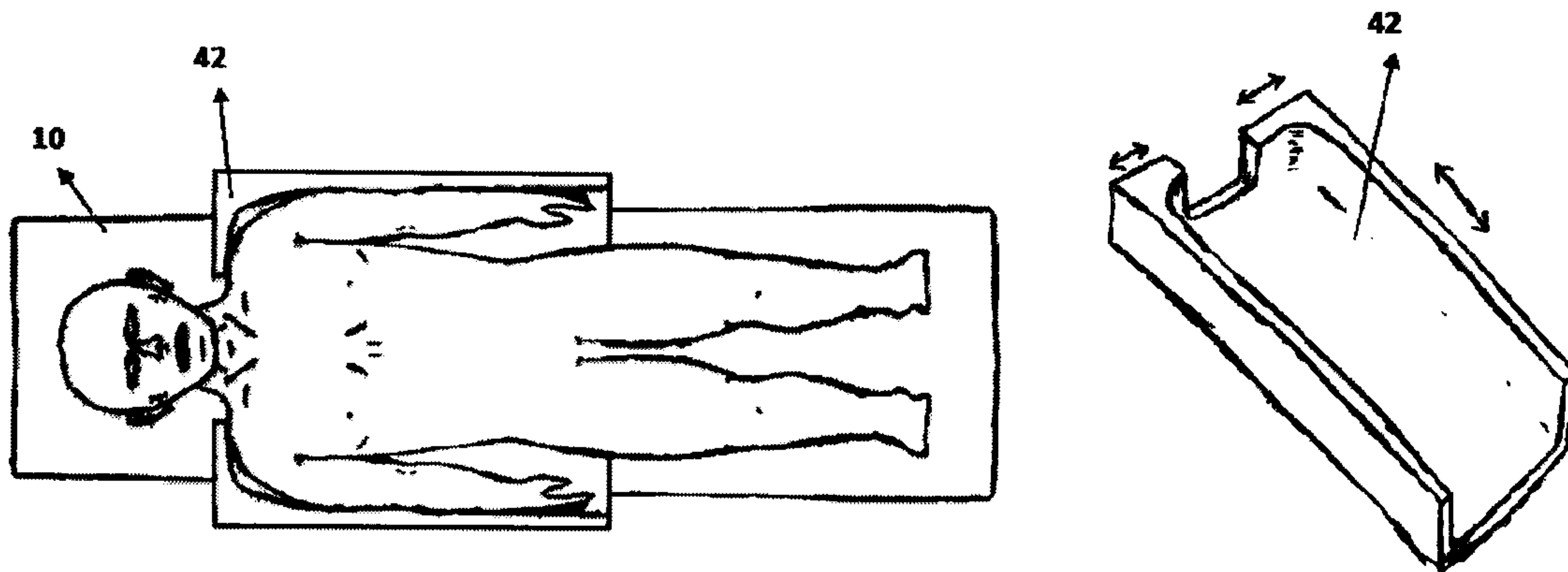

FIG. 7

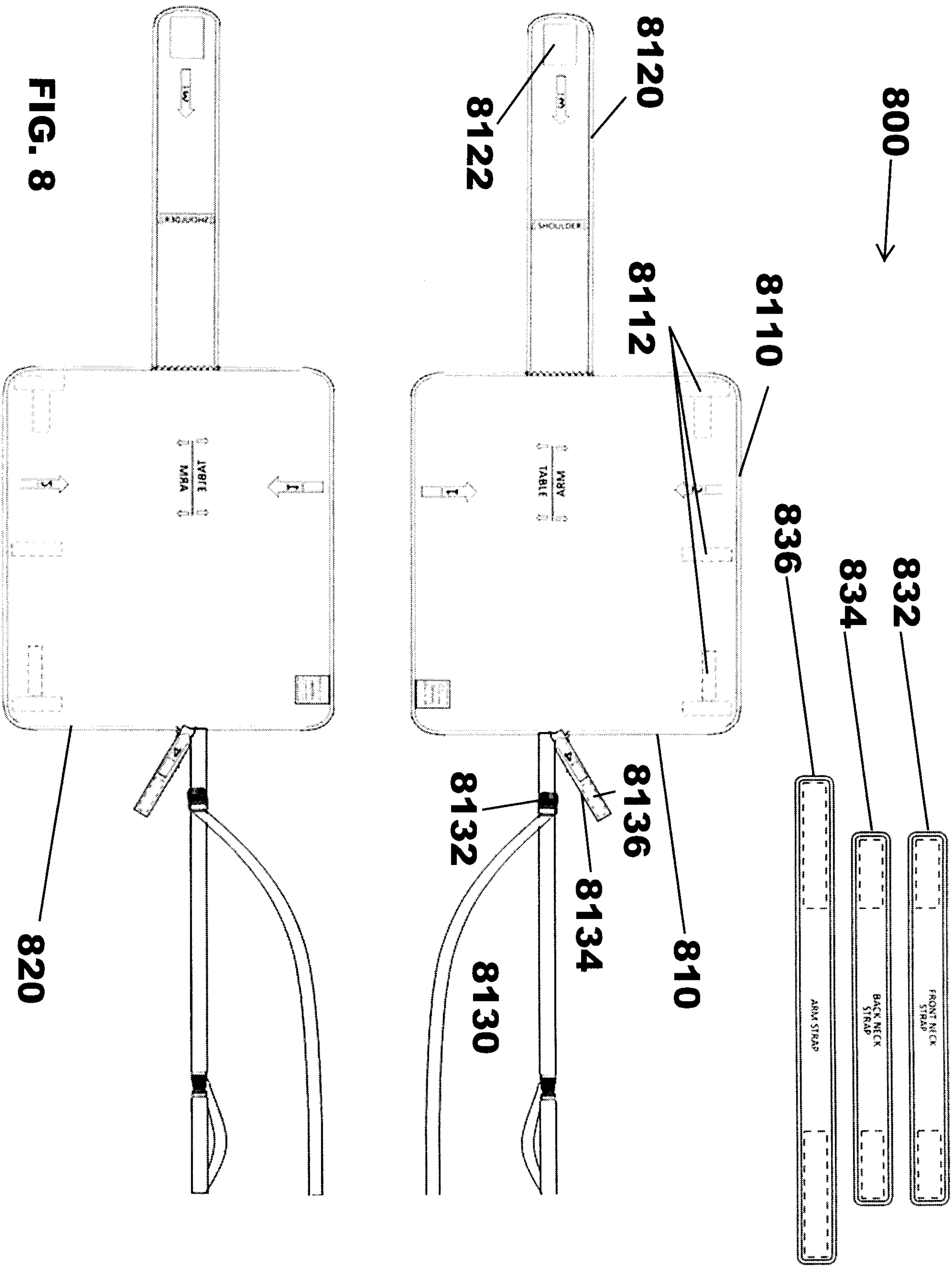
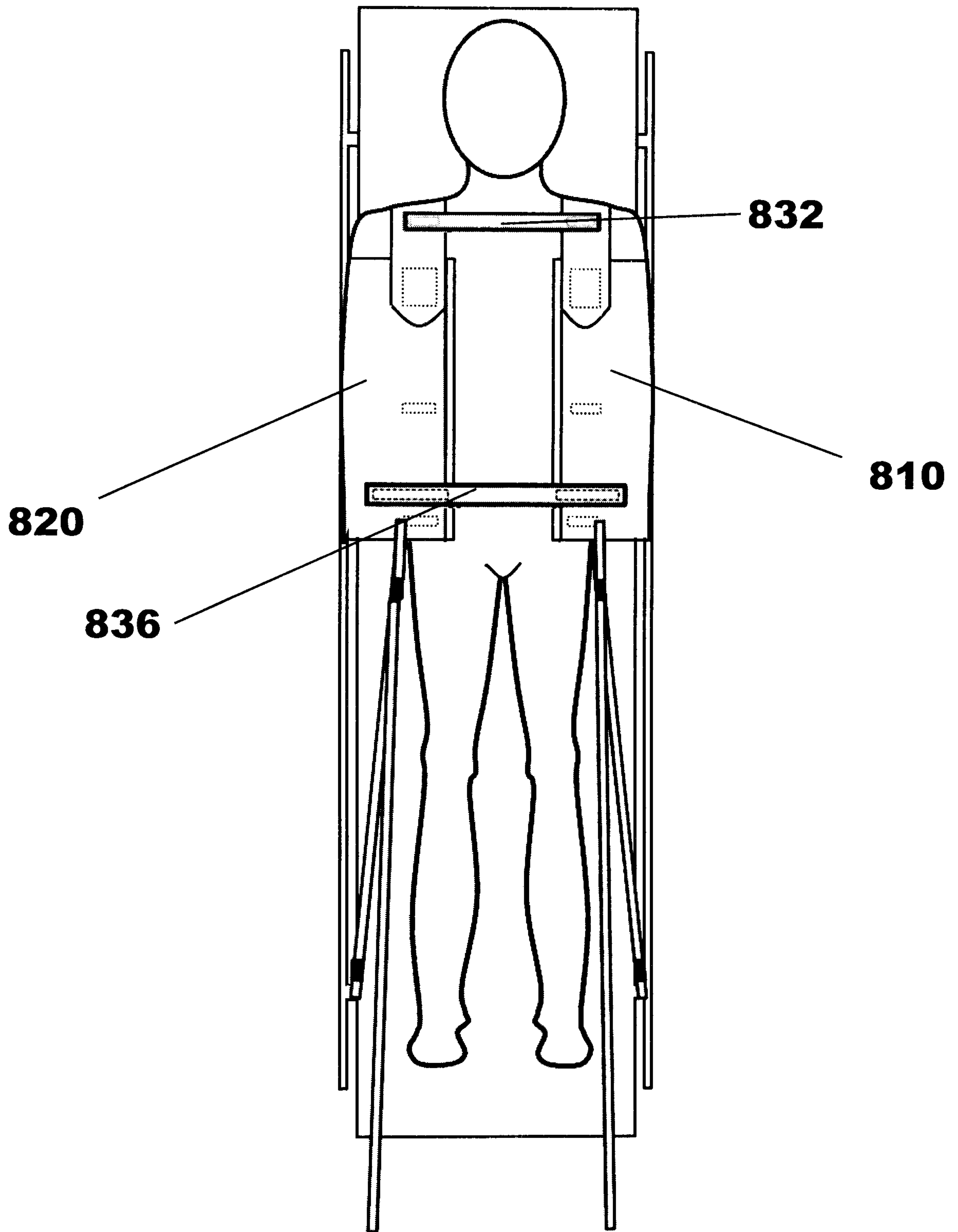

FIG. 8

820



**FIG. 9**

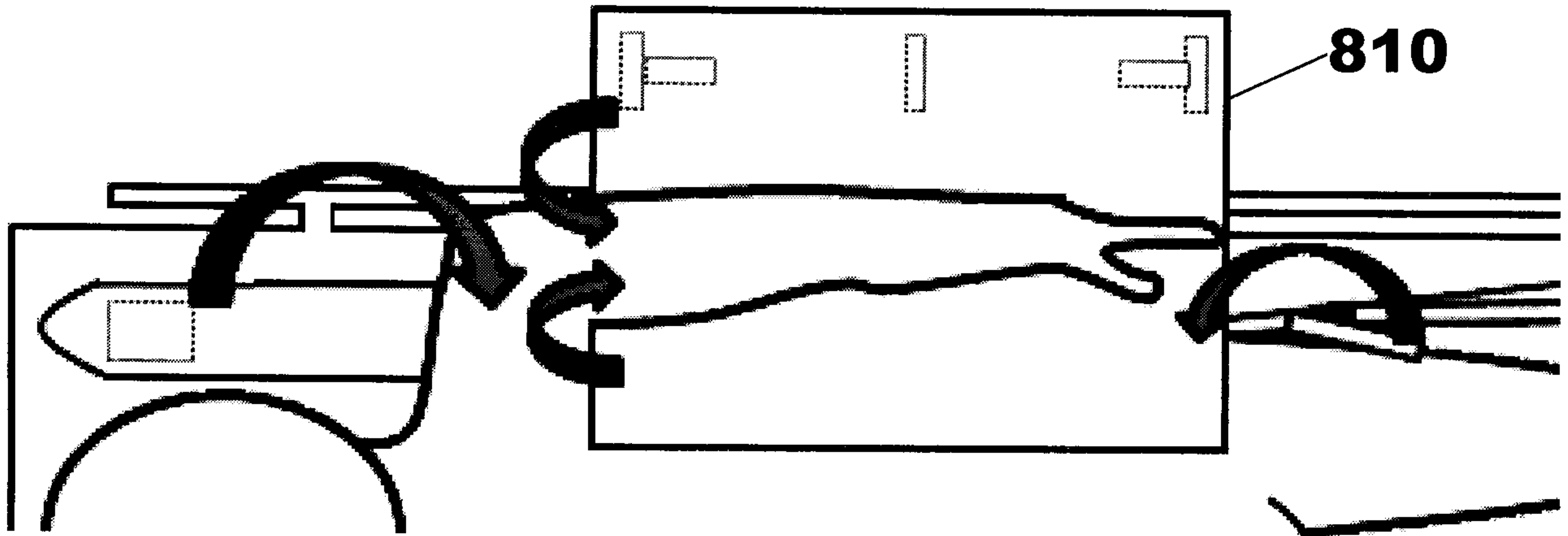

FIG. 10

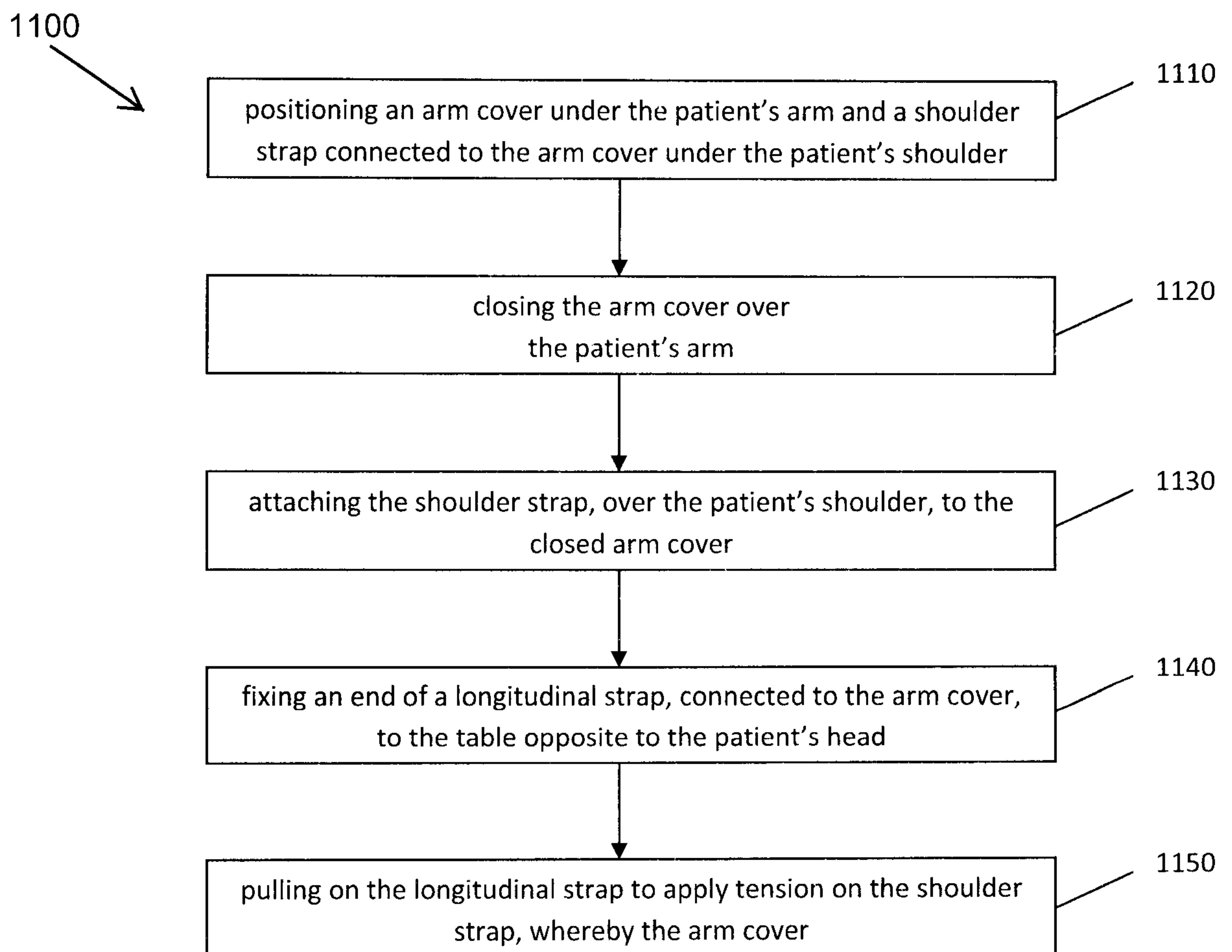

FIG. 11