



(19) **United States**

(12) **Patent Application Publication**
Yuan et al.

(10) **Pub. No.: US 2011/0288530 A1**

(43) **Pub. Date: Nov. 24, 2011**

(54) **DEVICE AND METHOD FOR DISTRACTION OF THE SPINAL DISC SPACE**

(30) **Foreign Application Priority Data**

Sep. 2, 2005 (US) PCT/US2005/031356

(75) Inventors: **Philip S. Yuan**, Long Beach, CA (US); **Kwan Ku Lin**, San Marino, CA (US); **Robert M. Scribner**, Niwot, CO (US)

Publication Classification

(51) **Int. Cl.**
A61M 5/00 (2006.01)
(52) **U.S. Cl.** **604/513; 604/288.01**

(73) Assignee: **Crosstrees Medical, Inc.**, Boulder, CO (US)

(57) **ABSTRACT**

(21) Appl. No.: **13/195,483**

An extractable device is used to insert a medicinal filling into a spinal disc. The device comprises a filling member and a flowable medicine. The filling member is made of a flexible and permeable wall and is provided with a holding portion and an injection port via which the flowable medicine is injected into the holding portion after the filling member is inserted into the spinal disc. The holding portion is provided with an opening which is releasably lashed by one end of one or more threads so as to make the opening leakproof. Upon completion of solidification of the flowable medicine in the holding portion of the filling member, other end of the thread is pulled to unlash the opening of the holding portion, thereby enabling the filling member to be extracted from the spinal disc so as to leave only the medicine in the spinal disc.

(22) Filed: **Aug. 1, 2011**

Related U.S. Application Data

(63) Continuation of application No. 12/829,500, filed on Jul. 2, 2010, now Pat. No. 7,993,345, which is a continuation of application No. 11/574,562, filed on Mar. 1, 2007, now Pat. No. 7,749,230, filed as application No. PCT/US05/31356 on Sep. 2, 2005.

(60) Provisional application No. 60/606,611, filed on Sep. 2, 2004.

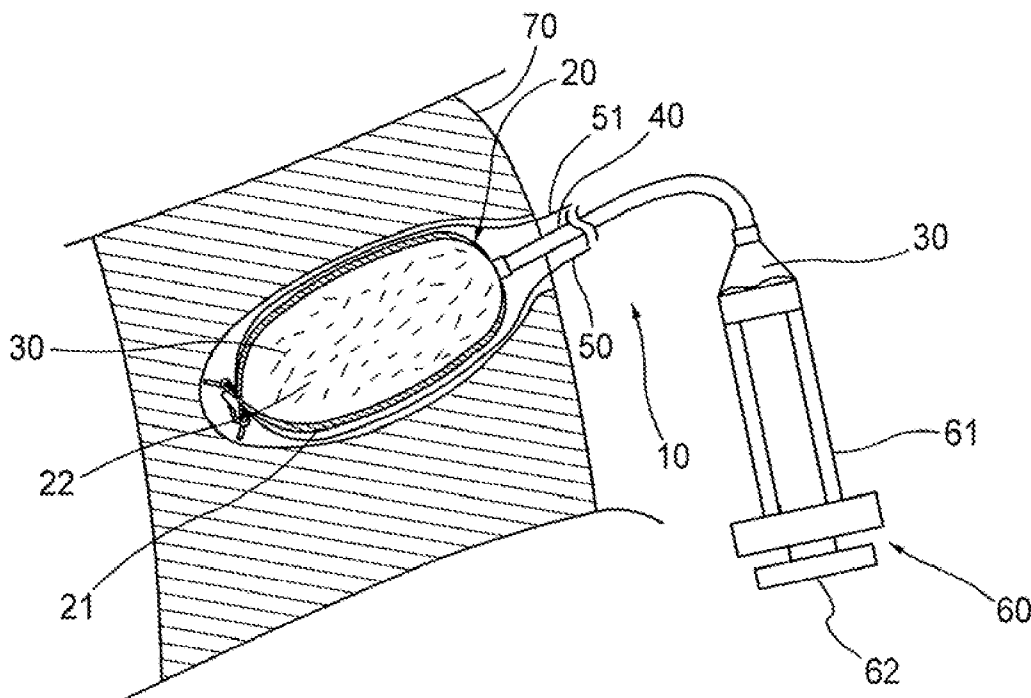

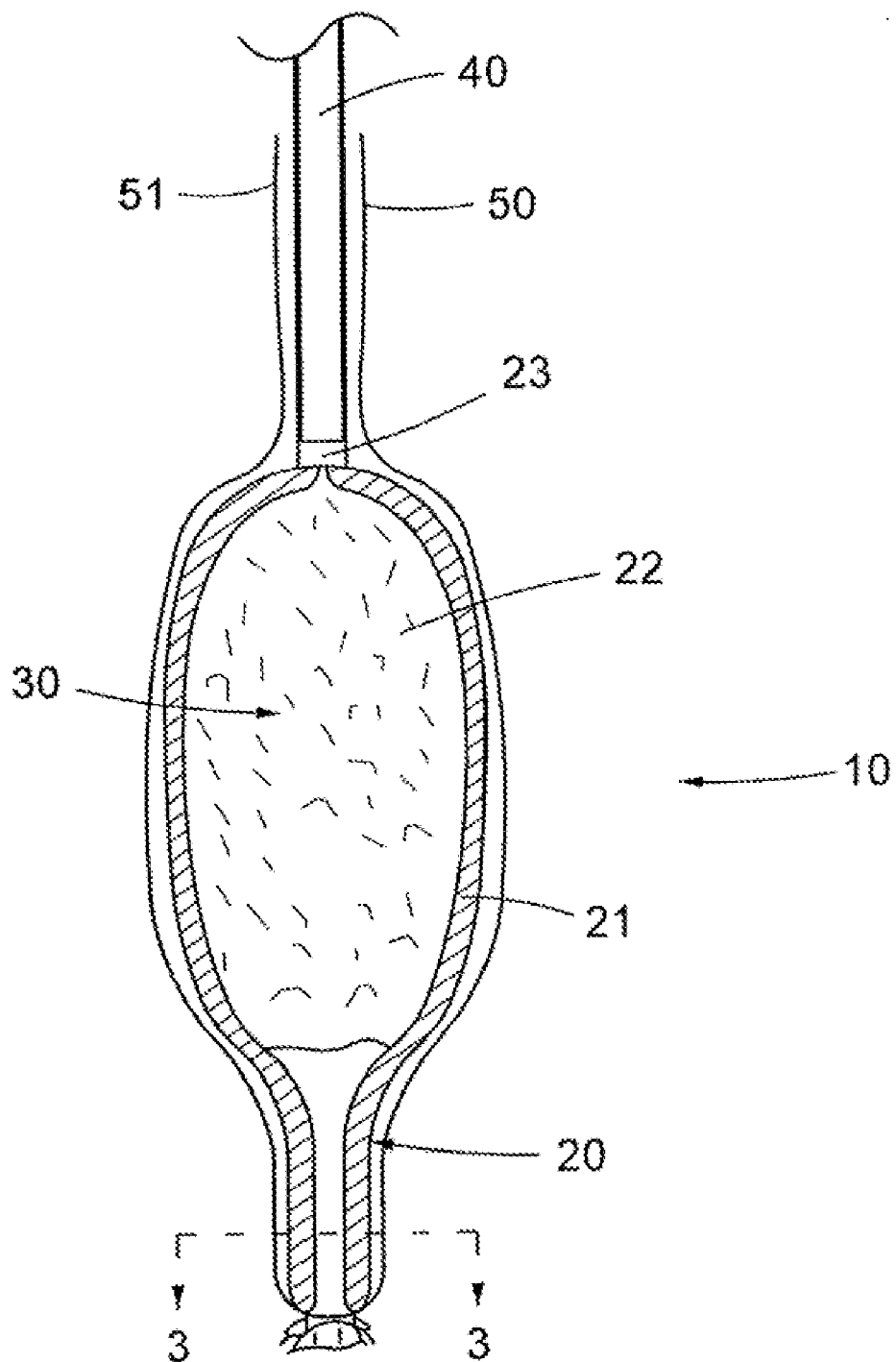
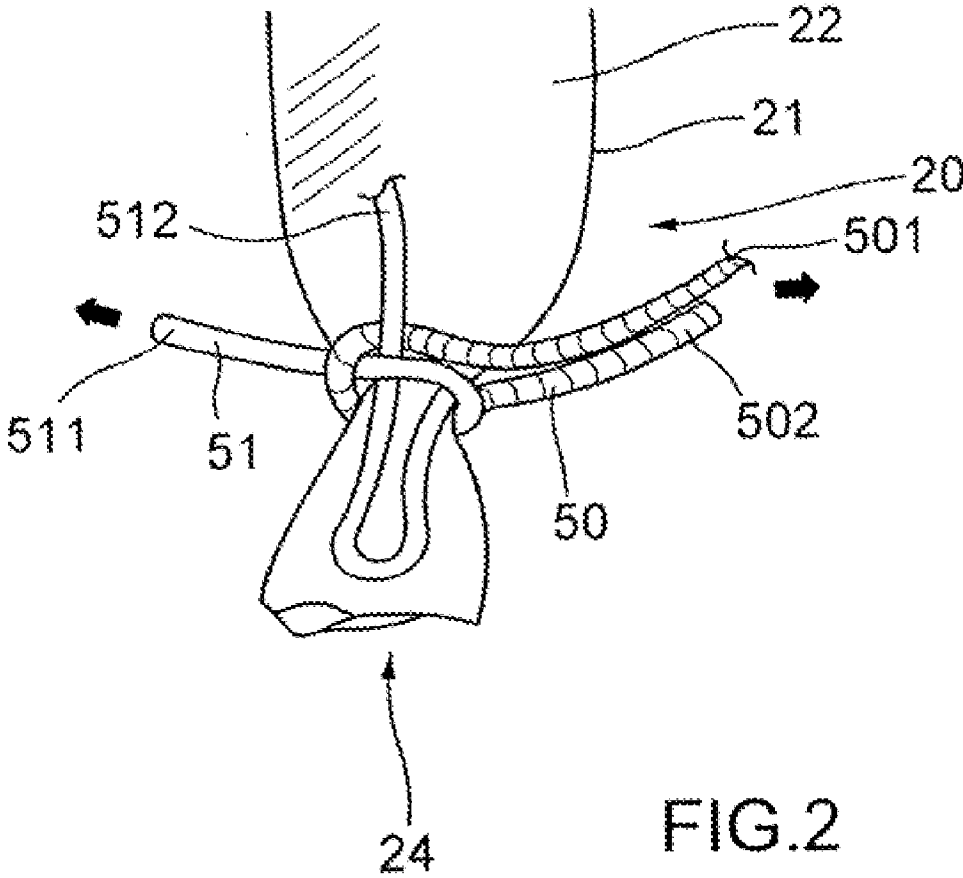

FIG.1



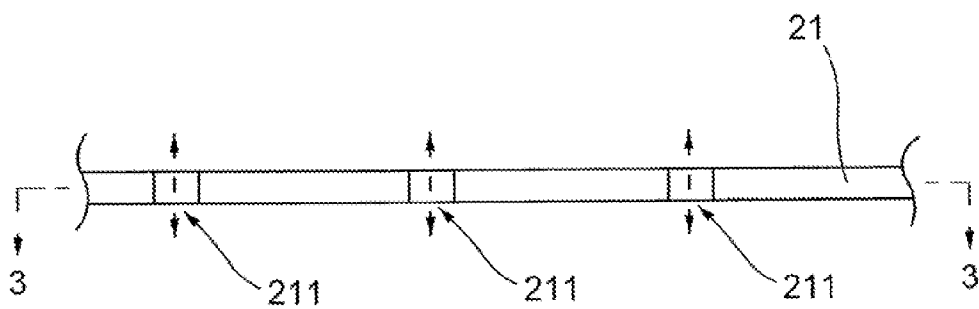

FIG.3a

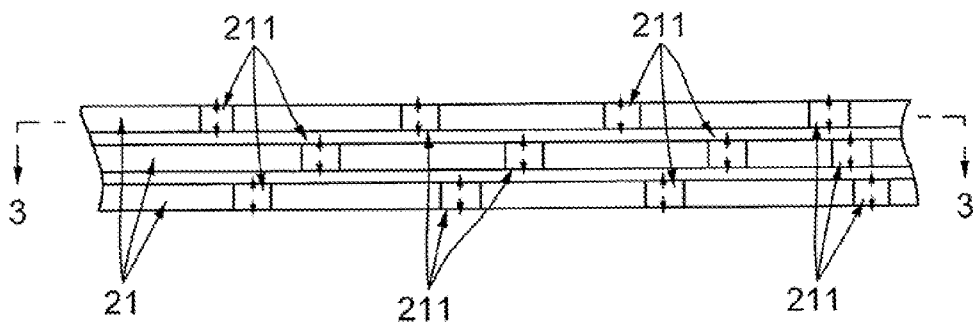
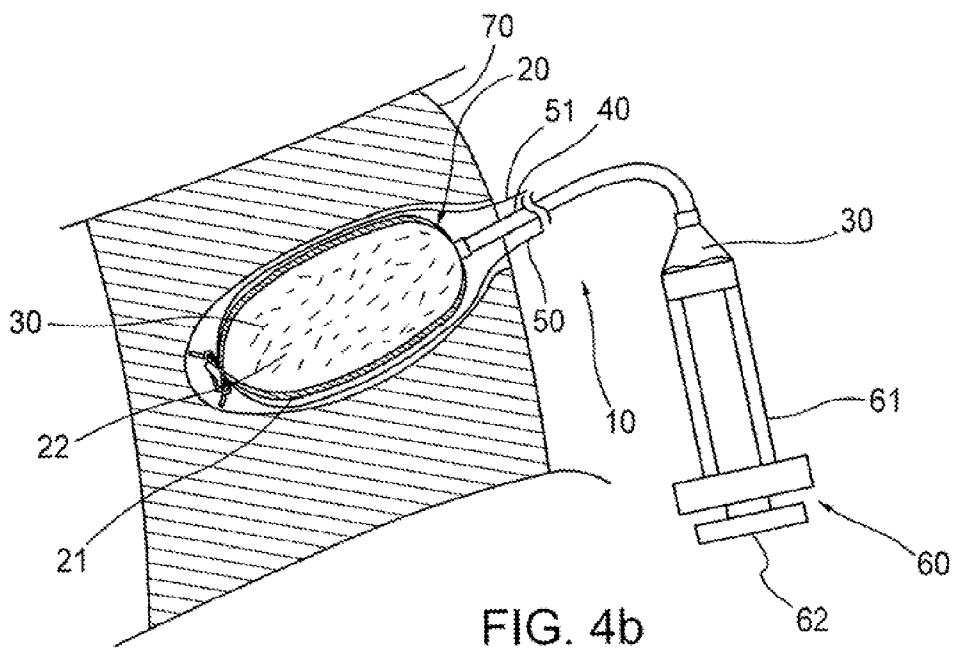
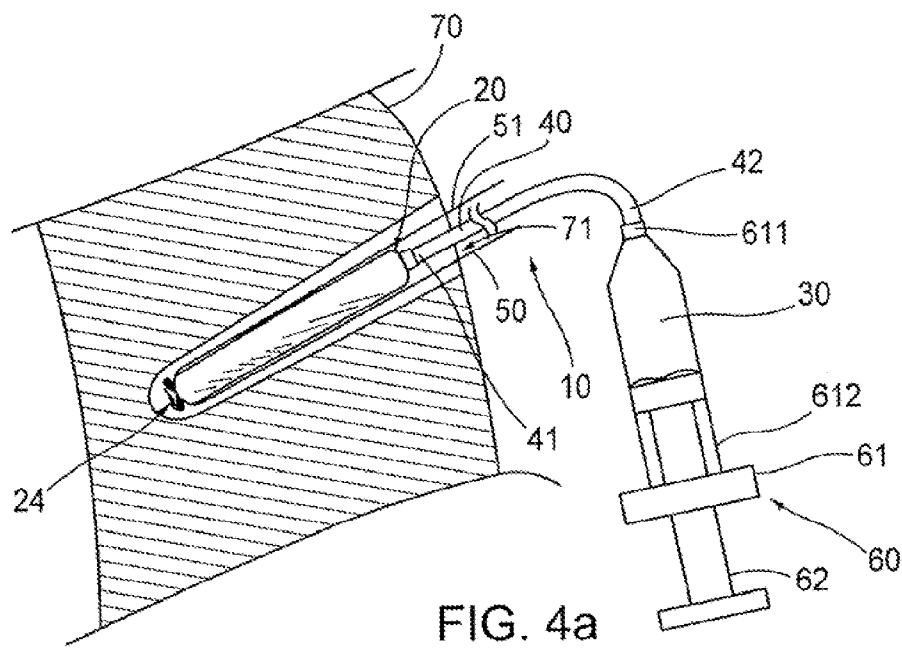

FIG.3b



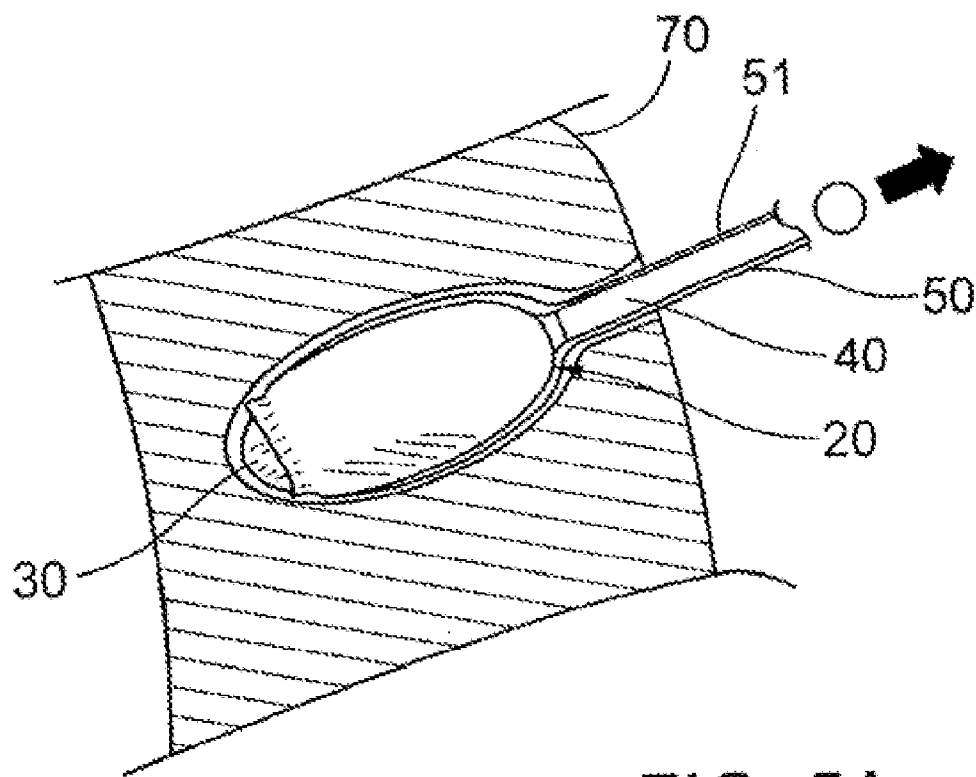

FIG. 5A

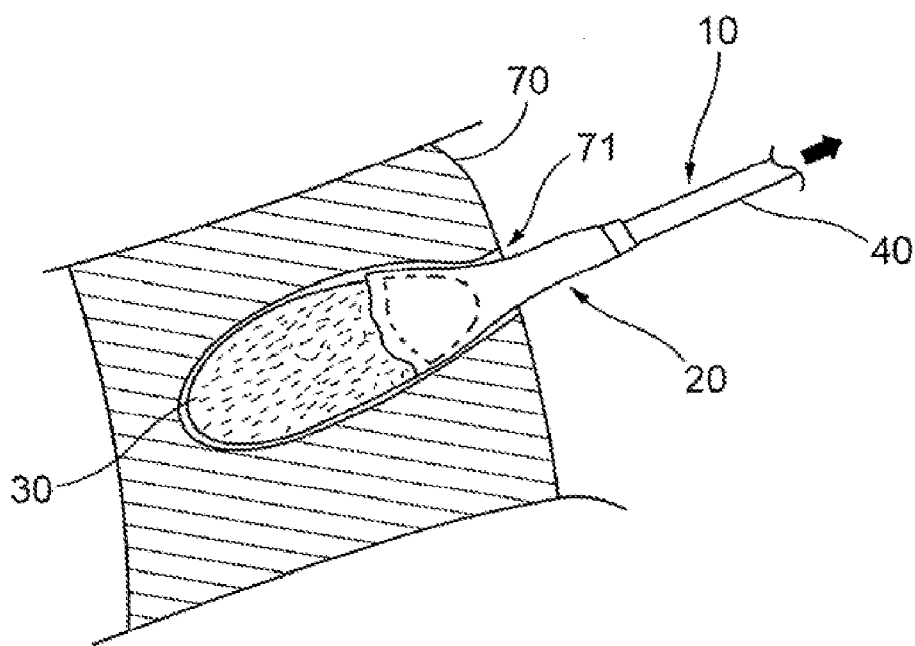

FIG. 5B

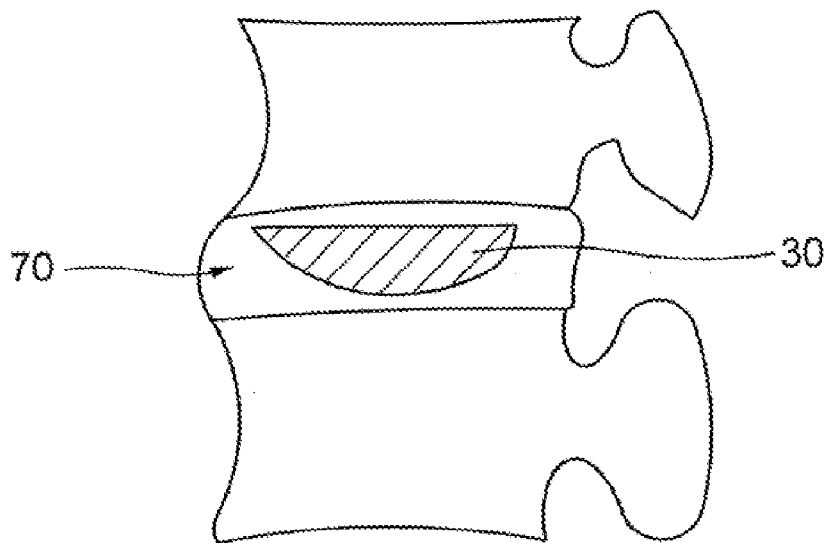

FIG. 6A

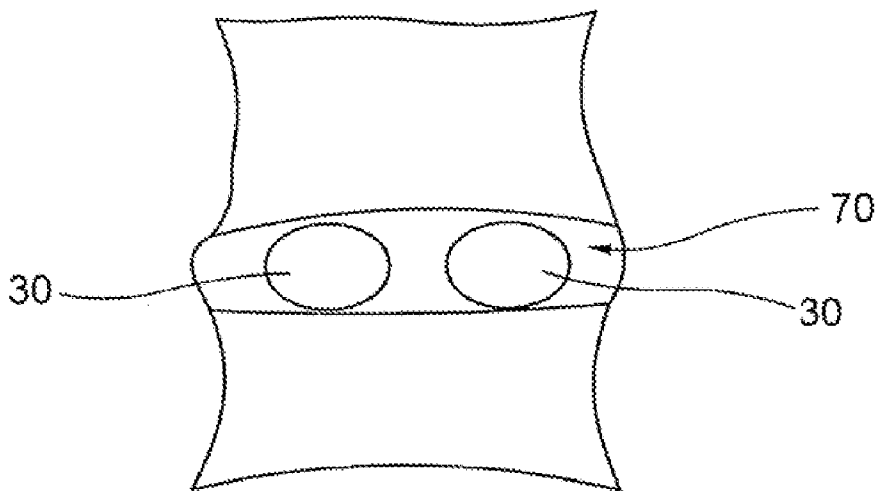

FIG. 6B

DEVICE AND METHOD FOR DISTRACTION OF THE SPINAL DISC SPACE

FIELD OF THE INVENTION

[0001] The present invention relates generally to an instrument which is used in the restorative surgical treatment of spine disorder. More specifically this surgical instrument can be used to insert a medical material into a spinal disc such that the instrument can be separated from the medical material and drawn out of the spinal disc, and the medical material remains in the spinal disc in a restorative function.

BACKGROUND OF THE INVENTION

[0002] The surgical treatment of spinal disc disorder can be generally attained by several methods, which include the hypodermic injection of medicine, the balloon-insertion of medicine, and the filler-insertion of medicine. For example, the U.S. Pat. Nos. 5,976,186, 6,508,839, and 6,602,291 disclose respectively methods for treating disorders of the spinal disc, such as placement of a prosthetic device or reconstruction of the damaged structure of the disc. These methods are defective in design in that disc disruption is required for placement of the therapeutic implant. The placement of a therapeutic implant by controlled delivery of a flowable material requiring minimal disruption of the disc is desirable. Without controlled delivery, the medicine is not contained and there is the possibility of injury to the surrounding tissues.

[0003] In order to prevent the drawbacks of the methods described above, the filler-insertion method is used to implant material in the spinal disc in such a way that the material is contained in the spinal disc, and that the material only remains implanted in the spinal disc.

SUMMARY OF THE INVENTION

[0004] An extractable device for inserting a medicinal filling into a spinal disc, said device comprising:

[0005] a filling member comprising a flexible wall and provided with a holding portion, an injection port at one end of the holding portion, and an opening at another end of the holding portion;

[0006] one or more thread, each having one end for fastening releasably said opening of said holding portion in such a manner that said opening is leakproof; and

[0007] a flowable medicine to be injected into said holding portion via said injection port of said filling member in the wake of a process for inserting said filling member into the spinal disc whereby said flowable medicine solidifies in said holding portion of said filling member;

[0008] said opening of said holding portion being unfastened at the time when other end of said threads is pulled by an external force, thereby enabling said filling member to be extracted from the spinal disc so as to leave only said flowable material in the spinal disc;

[0009] wherein the volume of said holding portion of said filling member is filled and is substantially tubular after being filled, wherein cross sections perpendicular to a longitudinal axis of the holding portion are substantially elliptical along a direction from the injection port to the opening of the holding portion.

[0010] Preferably, said flexible wall is provided with a plurality of through holes and is permeable. Said flexible and permeable wall is of a one-layered or multi-layered construction.

[0011] Preferably, said flowable medicine is a polymer substance such as a mixture which is flowable prior to setting to a non-viscous state such as PMMA, silicone, polyurethane, polyester, or other polymer.

[0012] Preferably, the device of the present invention further comprises an injection tool for injecting said flowable medicine into said holding portion via said injection port.

[0013] Preferably, said injection tool comprises a guide tube and a syringe, wherein one end of said guide tube is connected to said injection port of said filling member and another end of said guide tube is connected to said syringe in which said flowable medicine is held, so that said flowable medicine is able to be injected into said holding portion of said filling member by said syringe via said injection port and said guide tube.

[0014] Preferably, the device of the present invention further comprises a working tube for inserting into said spinal disc, so that said filling member together with said guide tube can be inserted into said working tube and said filling member can be disposed in said spinal disc.

[0015] Preferably, said tubular wall is provided with a plurality of through holes and is permeable.

[0016] The present invention also discloses a method for implanting a solidified medicine into a spinal disc comprising:

[0017] inserting a filling member in a hole of a spinal disc, said filling member comprising a flexible and permeable wall and provided with a holding portion, an injection port at one end of the holding portion, and an opening at another end of the holding portion, wherein one or more thread is provided and each having one end fastening releasably said opening of said holding portion in such a manner that said opening is leakproof, wherein said holding portion of said filling member is substantially tubular after being filled, wherein cross sections perpendicular to a longitudinal axis of the holding portion are substantially elliptical along a direction from the injection port to the opening of the holding portion;

[0018] injecting a flowable medicine into said holding portion via said injection port of said filling member, so that said holding portion is inflated and said flowable medicine solidifies in said holding portion of said filling member; and

[0019] unfastening said opening of said holding portion by pulling other end of said threads, thereby enabling said filling member to be extracted from the spinal disc so as to leave only said solidified medicine in the spinal disc,

[0020] wherein said solidified flowable medicine has a shape similar to that of the inflated holding portion.

[0021] Preferably, the method of the present invention further comprises fastening detachably an injection tool with said filling member, so that said flowable medicine is injected into said holding portion via said injection tool. More preferably, said injection tool comprises a guide tube and a syringe, wherein one end of said guide tube is connected to said injection port of said filling member and another end of said guide tube is connected to said syringe in which said flowable medicine is held, wherein said flowable medicine is injected into said holding portion of said filling member by said syringe via said injection port and said guide tube.

[0022] Preferably, the method of the present invention further comprises inserting a working tube in said hole of said spinal disc, and inserting said filling member together with said guide tube into said working tube, so that said filling member is disposed in said spinal disc.

[0023] The flexible wall of the filling member of the present invention is made of a biocompatible or biosynthetic material, such as polymer, rubber, elastic plastic, PTFE, Dacron, and like materials. The flexible wall is provided with a plurality of pores and is therefore permeable. Pores may be provided by fabricating the wall from a weave of selected material, or by perforation of a film of selected material. The flexible wall can be formed into an object in the form of sac, bag, ball, cylinder or rectangular column integrally or by joining separate pieces.

[0024] The filling member of the present invention may contain a radiopaque material, such as a metal wire, by which the precise position of the filling member can be easily located by an imaging system, such as X-ray imaging equipment.

[0025] The flexible wall of the filling member of the present invention may be of a one-layered or multi-layered construction, depending on the particle size and the viscosity of the medicine. If the particle size of the medicine is relatively large, the flexible wall is preferably of a two-layered construction. If the viscosity of the medicine is relatively high, the flexible wall is also preferably of a two-layered construction. On the other hand, the flexible wall is preferably of a three-layered or four-layered construction under the circumstances that the particle size of the medicine is relatively small and that the viscosity of the medicine is relatively lower.

[0026] The features and the advantages of the present invention will be more readily understood upon a thoughtful deliberation of the following detailed description of the preferred embodiments of the present invention with reference to the accompanying drawings.

BRIEF DESCRIPTION OF THE DRAWINGS

[0027] FIG. 1 shows a schematic view of an extractable filler of the present invention.

[0028] FIG. 2 is schematic view illustrating the lashing of the opening of the holding portion of the filling member of the present invention.

[0029] FIG. 3a shows a longitudinal sectional view of a one-layered wall of the filling member of the present invention.

[0030] FIG. 3b shows a longitudinal sectional view of a multi-layered wall of the filling member of the present invention.

[0031] FIG. 4a shows a sectional view of the filling member placed within the spinal disc.

[0032] FIG. 4b shows a sectional view of the filling member placed within the spinal disc containing a full volume of flowable material.

[0033] FIG. 5a shows a sectional view of the filling member with the said opening in the open condition.

[0034] FIG. 5b is a sectional view showing the removal of the filling member from the spinal disc.

[0035] FIG. 6a is a sectional view showing the flowable material within the spinal disc.

[0036] FIG. 6b is a sectional view showing the flowable material at more than one location within the spinal disc.

DETAILED DESCRIPTION OF THE PREFERRED EMBODIMENTS

[0037] As shown in FIG. 1, an extractable filler 10 embodied in the present invention comprises a filling member 20, a flowable medicine 30, a guide tube 40, and two threads 50 and

51. The filling member 20 is formed of a flexible wall 21 and is provided with a holding portion 22 and an injection port 23. The flexible wall 21 may be made of rubber or a flexible plastic material with perforated holes, or a woven fabric. The flowable medicine 30 is injected into the holding portion 22 via the guide tube 40 and the injection port 23. The dotted line 3-3 shows a direction in which a section of the filling member 20 is taken.

[0038] As shown in FIG. 2, the holding portion 22 of the filling member 20 is provided with an opening 24 opposite to the injection port 23 of the filling member 40. The opening 24 is lashed by two threads 50 and 51. The first thread 50 has a first end 501 and a second end 502, while the second thread 51 has a first end 511 and a second end 512. The two threads 50 and 51 are in fact fastened releasably to the flexible wall 21 near the opening 24. The way by which they are fastened together is not shown in the drawing.

[0039] The opening 24 of the holding portion 22 of the filling member 20 is securely tied up to prevent the medicine 30 from leaking out of the holding portion 22 by means of the two threads 50 and 51 which are releasably entangled in such a manner that the first end 511 of the second thread 51 is wound around the first thread 50. Upon completion of the winding process, the flexible wall 21 surrounding the opening 24 is located in a position between the two threads 50 and 51. Thereafter, both ends 501 and 502 of the first thread 50, and the first end 511 of the second thread 51 are respectively pulled rightward and leftwards at the same time, as illustrated in FIG. 2. As a result, the opening 24 of the filling member 20 is leakproof. The opening 24 of the filling member 20 is untied when the second end 512 of the second thread 51 is pulled in the direction of the injection port 23. As a result, the two threads 50 and 51 become loosened. Thereafter, the first end 501 of the first thread 50 and the second end 512 of the second thread 51 are respectively pulled in a direction away from the opening 24 of the filling member 20, as illustrated in FIG. 5a. The opening 24 is thus unfastened completely.

[0040] The flexible wall 21 of the filling member 20 is of a one-layered construction, as shown in FIG. 3a, or of a multi-layered construction, as shown in FIG. 3b. The flexible wall 21 is provided with a plurality of pores 211 permeable to fluids. If the flexible wall 21 is of a multi-layered construction, the flexible walls 21 are laminated in such a way that the pores 211 are not corresponding in location to slow down the passage of the fluids.

[0041] As shown in FIG. 4a, the filling member 20 of the extractable filler 10 is inserted into a hole 71 formed on a spinal disc 70, wherein a working tube 51 is inserted into the hole 71 in advance to accommodate the guide tube 40, the threads 50 and 51 and the filling member 20. The flowable medicine is then injected into the holding portion 21 of the filling member 20 by a syringe in conjunction with the guide tube 40. The guide tube 40 has one end 41 in the holding portion 21, and another end 42 connected to one end 611 of a barrel 612 of the syringe 80. A plunger 62 is inserted into another end of the barrel 612 in which the pasty medicine 30 is contained. The filling member 20 is thus inflated by the medicine 30, as shown in FIGS. 4a and 4b.

[0042] Preferably, said flowable medicine 30 is a polymer substance such as a mixture which is flowable prior to setting to a non-viscous state such as PMMA, silicone, polyurethane, polyester, or other polymer.

[0043] Upon completion of the solidification of the pasty medicine 30 in the filling member 20 within the spinal disc

70, the filling member 20 must be extracted from the hole 71 of the spinal disc 70, so as to leave only the medicine 30 in the spinal disc 70. The extraction of the filling member 20 from the hole 71 of the spinal disc 70 involves a first step in which the second end 512 of the second thread 51 is pulled in the direction of the filler opening 23. As a result, the two threads 50 and 51 become loosened. Thereafter, the first end 501 of the first thread 50 and the second end 512 of the second thread 51 are respectively pulled in a direction away from the opening 24 of the filling member 20, as illustrated in FIG. 5a. The opening 24 is thus unfastened completely.

[0044] After the opening 24 being unfastened, the flexible wall 21 is retreated from the solidified medicine 30 by pulling one end of the flexible wall 21 connected to the guide tube 40 at the injection port 23 of said holding portion of the said filling member 20, whereby said solidified medicine 30 is released from said filling member 20 and is disposed in the spinal disc 70, as shown in FIG. 5b. The filling member and the guide tube 40 are pulled from the hole 71 of the spinal disc 70, so as to leave only said solidified medicine 30 in the spinal disc 70.

[0045] The flexible wall 21 of the filling member 20 of the extractable filler 10 of the present invention may have a curved profile. As shown in FIG. 6a, the flowable material 30 injected into the filling member 20 in the spinal disc 70 will also have a curved profile when remaining within the spinal disc 70.

[0046] As shown in FIG. 6b, the filling member 20 may be placed at more than one location in the spinal disc, with the flowable material 30 remaining at more than one location in the spinal disc 70.

[0047] The above embodiments are, in all respects, illustrative and nonrestrictive. The invention may be embodied in other specific forms without deviating from the scope of the following claims.

What is claimed is:

1. An extractable device for inserting a medicinal filling into a spinal disc, said device comprising:

a filling member comprising a flexible wall and provided with a holding portion, an injection port at one end of the holding portion, and an opening at another end of the holding portion;

one or more thread fastening releasably said opening of said holding portion in such a manner that said opening is leakproof; and

a flowable medicine to be injected into said holding portion via said injection port of said filling member in the wake of a process for inserting said filling member into the spinal disc;

said opening of said holding portion being opened, thereby enabling said filling member to be extracted from the spinal disc so as to leave only said medicine in the spinal disc.

2. The device as defined in claim 1, wherein said flexible wall is provided with a plurality of through holes and is permeable.

3. The device as defined in claim 2, wherein said flexible and permeable wall is of a one-layered or multi-layered construction.

4. The device as defined in claim 1, wherein said flowable material is a polymer capable of setting to a non-viscous state.

5. The device as defined in claim 1 further comprising an injection tool for injecting said flowable medicine into said holding portion via said injection port.

6. The device as defined in claim 5, wherein said injection tool comprises a guide tube and a syringe, wherein one end of said guide tube is connected to said injection port of said filling member and another end of said guide tube is connected to said syringe in which said flowable medicine is held, so that said flowable medicine is able to be injected into said holding portion of said filling member by said syringe via said injection port and said guide tube.

7. The device as defined in claim 6 further comprising a working tube for inserting into said spinal disc, so that said filling member together with said guide tube can be inserted into said working tube and said filling member can be disposed in said spinal disc.

8. The device as defined in claim 3, wherein said tubular wall is provided with a plurality of through holes and is permeable.

9. A method for implanting a solidified medicine into a spinal disc comprising:

inserting a filling member in a hole of a spinal disc, said filling member comprising a flexible and permeable wall and provided with a holding portion, an injection port at one end of the holding portion, and an opening at another end of the holding portion, wherein one or more thread is provided and each having one end fastening releasably said opening of said holding portion in such a manner that said opening is leakproof, wherein said holding portion of said filling member is inflatable;

injecting a flowable medicine into said holding portion via said injection port of said filling member, so that said holding portion is inflated and said flowable medicine solidifies in said holding portion of said filling member; and

unfastening said opening of said holding portion by pulling other end of said threads, thereby enabling said filling member to be extracted from the spinal disc so as to leave only said solidified medicine in the spinal disc, wherein said solidified flowable medicine has a shape similar to that of the inflated holding portion.

10. The method as defined in claim 9, wherein said flowable material is a polymer capable of setting to a non-viscous state.

11. The method as defined in claim 9 further comprising fastening detachably an injection tool with said filling member, so that said flowable medicine is injected into said holding portion via said injection tool.

12. The method as defined in claim 11, wherein said injection tool comprises a guide tube and a syringe, wherein one end of said guide tube is connected to said injection port of said filling member and another end of said guide tube is connected to said syringe in which said flowable medicine is held, wherein said flowable medicine is injected into said holding portion of said filling member by said syringe via said injection port and said guide tube.

13. The method as defined in claim 12 further comprising inserting a working tube in said hole of said spinal disc, and inserting said filling member together with said guide tube into said working tube, so that said filling member is disposed in said spinal disc.

* * * * *