

⑫

**EUROPEAN PATENT APPLICATION**

⑳ Application number: **88121579.2**

⑤ Int. Cl.4: **F02D 11/10 , F02M 19/12**

㉑ Date of filing: **23.12.88**

㉓ Priority: **29.12.87 GB 8730207**

㉔ Date of publication of application:  
**05.07.89 Bulletin 89/27**

㉕ Designated Contracting States:  
**DE ES FR IT SE**

㉗ Applicant: **Siemens Aktiengesellschaft Berlin und München**  
**Wittelsbacherplatz 2**  
**D-8000 München 2(DE)**

Applicant: **CRYSTALATE ELECTRONICS LIMITED**  
**Wharf House Medway Wharf Road**  
**Tonbridge Kent TN9 1RE(GB)**

㉘ Inventor: **Schreiber, Hans, Dipl.-Ing.**  
**Könighausen 1c**  
**D-8417 Lappersdorf(DE)**  
Inventor: **Joyce, Philip Leslie**  
**38 Neville Road**  
**Dagenham Essex RM8 3QS(GB)**

㉙ Representative: **Mehl, Ernst, Dipl.-Ing. et al**  
**Postfach 22 13 17**  
**D-8000 München 22(DE)**

㉚ **Pedal return arrangement.**

㉛ An accelerator pedal return arrangement for an automotive vehicle with an electronic engine management system has a pedal position sensor, suitably in the form of a potentiometer, adapted to be connected to a voltage source (15) and providing an output voltage or current at a terminal (12), dependant upon the position of the pedal, for controlling the speed of the engine. One or more springs (4, 4A) are provided to return the pedal to a predetermined rest position when released after being depressed, the or each spring (4, 4A) being of electrically conducting material and included in a supervisory circuit, an electrical resistor (16, 16A) being provided connected in parallel with the or each spring (4, 4A), the arrangement being such that if a spring (4, 4A) breaks, electric current flowing in the supervisory circuit from the source (15) to the pedal position sensor then flows through the resistor (4, 4A) and the magnitude of the current is thereby reduced, whereby the speed of the engine is re-

duced to a safe level.

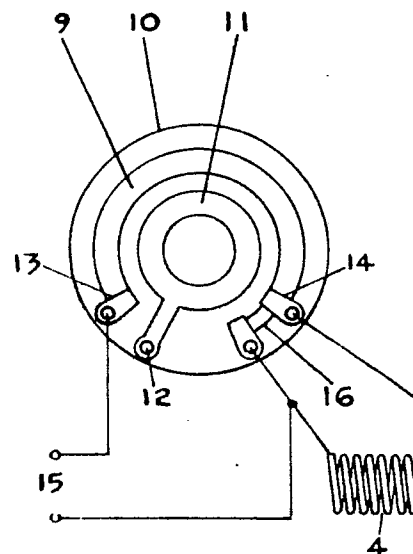

**FIG. 2**

**EP 0 322 785 A2**

This invention relates to automotive vehicles incorporating electronic engine management systems and more particularly to an accelerator pedal arrangement for such vehicles which is connected to a pedal position sensor and incorporates a spring to return the pedal to a rest position when released after being depressed by a driver of the vehicle.

In electronic management systems for automotive vehicle engines a position sensor, such as a potentiometer, is generally provided to sense the position of an engine throttle, or of an accelerator pedal used to control the engine. Developments have resulted in the elimination of mechanical linkages between the accelerator pedal and the engine throttle. A position sensor, such as a potentiometer is sometimes now connected to the accelerator pedal to sense the position of the pedal and provide electrical output signals, dependant upon the pedal position, over electrical wiring to electronic control means for the engine throttle. A spring is generally provided to return the accelerator pedal to a predetermined rest position when released after being depressed by a driver of the vehicle. A problem can arise if this return spring breaks while the vehicle is being driven in that the vehicle will not slow down when the driver's foot is removed from the accelerator pedal and an accident may be caused.

It is an object of the present invention to overcome or minimise this problem by providing a means whereby the vehicle will automatically slow down if the pedal return spring breaks.

The present invention provides an accelerator pedal return arrangement for use with an electronic engine management system for an automotive vehicle and in which a pedal position sensor is provided adapted to be connected to a voltage source and to provide an output signal, dependant upon the position of the pedal for controlling the speed of the engine, a spring being provided for returning the pedal to a predetermined rest position when the pedal is released after being depressed, the said arrangement being characterised in that the spring is of electrically conducting material and is included in a supervisory circuit, an electrical resistor being provided connected in parallel with the spring, the arrangement being such that if the spring breaks electric current in the supervisory circuit flows through the resistor and the magnitude of the said current is thereby reduced, whereby the speed of the engine is reduced to a safe level.

If desired, a plurality of said springs may be provided electrically connected in series and each having an electrical resistor connected in parallel with it and operating such that breakage of successive springs will result in successive reduction in

the magnitude of the said current.

In a particular embodiment the supervisory circuit is arranged such that the voltage from the source is applied to, or the output signal is received from, the position sensor through the or each spring, breakage of the or each spring resulting in the magnitude of the output signal from the position sensor being reduced, whereby the speed of the engine is reduced to a safe level.

The pedal position sensor may suitably comprise a potentiometer, of rotary or linear form, mechanically linked to the pedal and providing an output signal in the form of a voltage of magnitude dependant upon the position of the pedal. The electrical resistor connected in parallel with the spring may be provided externally to the potentiometer or may be incorporated within the potentiometer. When incorporated within the potentiometer and the potentiometer includes a resistive track and associated conductors in film form on an electrically insulating substrate, the resistor may also be suitably provided in film form on the same substrate and provided with electrical conductors for connection to the spring.

The invention is now described by way of example with reference to the accompanying drawings in which:

Figure 1 represents a sectional view of an accelerator pedal return arrangement with an associated pedal position sensor in the form of a potentiometer and incorporating a return arrangement.

Figure 2 represents a plan view of a substrate incorporated in the potentiometer of Figure 1, showing an arcuate resistive track, and also a resistor arranged for connection in parallel with a pedal return spring, the latter being shown schematically.

Figure 3 represents an alternative to the arrangement of Figure 2 for use where two pedal return springs are employed.

An accelerator pedal return arrangement is constructed as follows. A shaft 1 is arranged for rotation in bearings 2 in a housing 3. The end 1A of the shaft is mechanically connected to an accelerator pedal (not shown) of known form in an automotive vehicle and a spring 4 of electrically conductive material (ie metal) is mounted inside the housing 3. The spring 4 is arranged such that when the accelerator pedal is depressed from a fixed rest position, the shaft 1 is rotated against pressure from the spring 4.

When the pedal is released, the spring 4 rotates the shaft 1 in the opposite direction and returns the pedal to its fixed rest position. The end 1B of the shaft is mechanically connected to a pedal position sensor in the form of a rotary potentiometer 5. The potentiometer 5 is basically of well-known construction and comprises a casing 6 in-

corporating a rotatable wiper carrier 7 supporting an electrically conductive wiper assembly 8. The wiper carrier 7 is secured to the end 1B of the shaft 1 for rotation therewith and the wiper assembly 8 is arranged to traverse an arcuate film resistive track 9 (Figure 2). An electrically conductive collector track 11 is also provided on the substrate 10 and arranged to be traversed by the wiper assembly 8. An electrically conductive terminal 12 is connected to the collector track 11 and serves as an electrical output terminal for the potentiometer. Electrically conductive terminals 13, 14 are provided at opposite ends of the resistive track 9 and to which a voltage is to be applied from a source 15. Instead of the voltage from the source 15 being applied in the usual manner directly to the terminals 13 and 14 of the potentiometer, it is arranged for it to be applied to terminal 14 through the pedal return spring 4. Additionally, an electrical resistor 16 of film form is provided on the substrate 10 and electrically connected in parallel with the spring 4.

An output current or voltage signal is obtained at the terminal 12 of magnitude proportional to the position of the accelerator pedal and this output signal is applied to control the speed of the vehicle engine. If, while the accelerator pedal is depressed by a driver, the spring 4 should break and thereby loses its electrical continuity, the voltage from the source 15 is no longer applied to the terminal 14 of the potentiometer through the spring 4, but is applied instead through the resistor 16 in parallel with the spring 4. When this occurs, electric current which previously flowed through the spring 4 flows through the resistor 16 and is thereby reduced in magnitude. The output current or voltage signal at the terminal 12 immediately reduces in magnitude and the speed of the engine, and hence of the vehicle reduces to a safe level. This takes place even though when the driver's foot is lifted off the pedal, the pedal does not return to its fixed rest position. It will be appreciated that in the absence of the resistor 16 and without the voltage being applied to the potentiometer through the spring 4, if the spring 4 should break with the accelerator pedal depressed, the vehicle would not slow down when the driver's foot was lifted from the pedal. A dangerous situation could result.

Instead of the voltage from the source 15 being applied to the potentiometer through the spring 4, the output voltage signal at the output terminal 12 could be arranged to pass through the spring 4, a resistor similar to resistor 16 being connected in parallel with the spring 4.

If required a further spring 4A could be provided as shown in Figure 3, connected in series with the spring 4 and having a resistor 16A connected in parallel with it. With this arrangement,

successive breakage of springs 4 and 4A would result in successive reductions in the magnitude of the output voltage signal at terminal 12 and hence successive reductions in the speed of the vehicle.

Although the resistor 16 connected in parallel with the spring 4 is shown in the accompanying drawings as being provided of film form within the potentiometer, it is not necessary that this be so. The resistor could be provided of discrete form within the potentiometer, or of film or discrete form at a suitable location outside of the potentiometer.

### Claims

1 An accelerator pedal return arrangement for use with an electronic engine management system for an automotive vehicle and in which a pedal position sensor is provided adapted to be connected to a voltage source and to provide an output signal, dependant upon the position of the pedal for controlling the speed of the engine, a spring being provided for returning the pedal to a predetermined rest position when the pedal is released after being depressed, the said arrangement being characterised in that the spring is of electrically conducting material and is included in a supervisory circuit, an electrical resistor being provided connected in parallel with the spring, the arrangement being such that if the spring breaks electric current in the supervisory circuit flows through the resistor and the magnitude of the said current is thereby reduced, whereby the speed of the engine is reduced to a safe level.

2 An accelerator pedal return arrangement according to Claim 1 in which a plurality of said springs is provided electrically connected in series and each having an electrical resistor connected in parallel with it and operating such that breakage of successive springs will result in successive reduction in the magnitude of the said current.

3 An accelerator pedal return arrangement according to Claim 1, or 2, in which the supervisory circuit is arranged such that the voltage from the source is applied to, or the output signal is received from, the position sensor through the or each spring, breakage of the or each spring resulting in the magnitude of the output signal from the position sensor being reduced, whereby the speed of the engine is reduced to a safe level.

4 An accelerator pedal return arrangement according to Claim 1, 2, or 3, in which the pedal position sensor comprises a potentiometer, of rotary or linear form, mechanically linked to the pedal and providing an output signal in the form of a voltage of magnitude dependant upon the position of the pedal.

5 An accelerator pedal return arrangement according to Claim 4 in which the electrical resistor is incorporated within the potentiometer.

6 An accelerator pedal return arrangement according to Claim 5 in which the potentiometer includes a resistive track and associated conductors in film form on an electrically insulating substrate and the resistor is also of film form on the same substrate and provided with electrical conductors for connection to the spring.

7 An accelerator pedal return arrangement constructed and arranged substantially as hereinbefore described with reference to the accompanying drawings.

8 An automotive vehicle provided with an accelerator pedal return arrangement according to any preceding Claim.

5

10

15

20

25

30

35

40

45

50

55

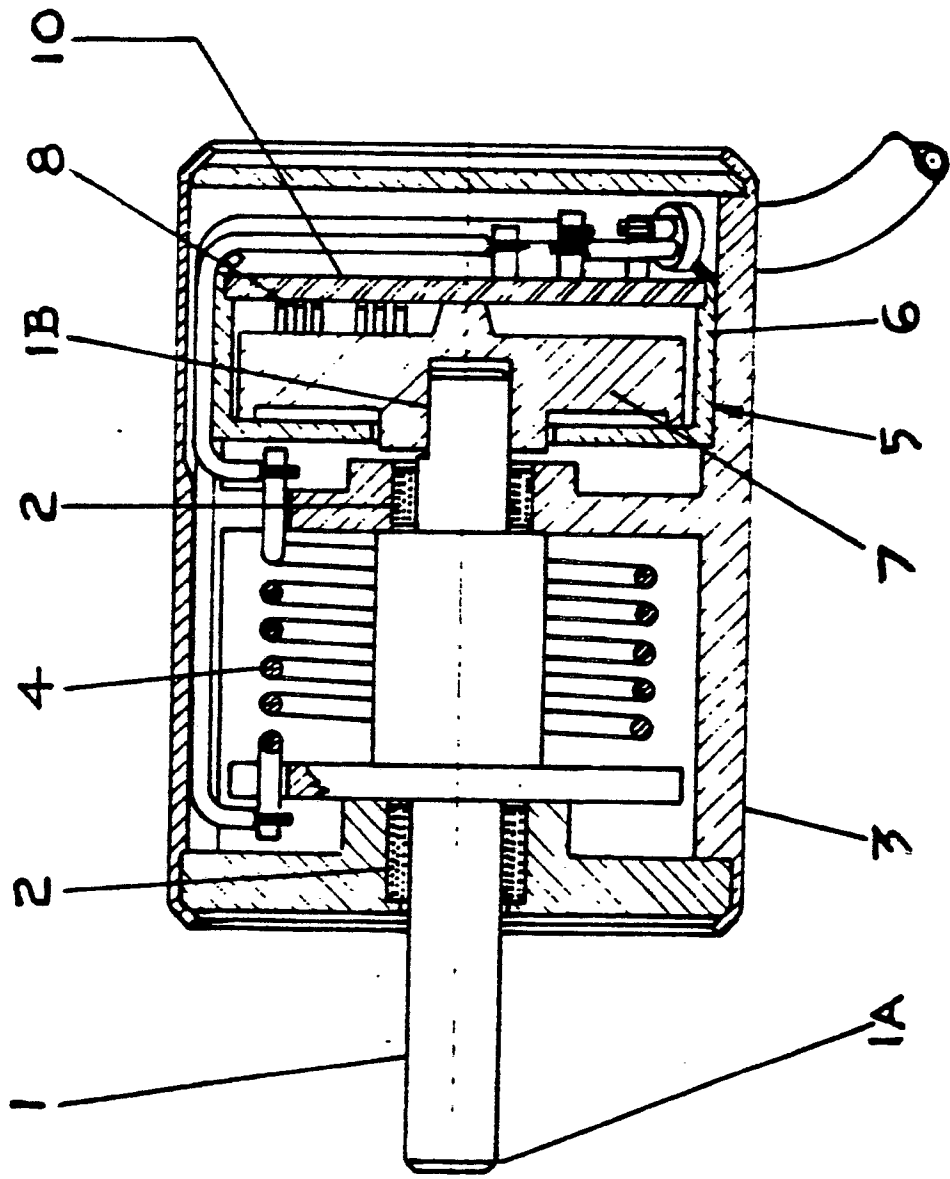

FIG. 1