



US00D896702S

(12) **United States Design Patent**
Dunshee et al.

(10) **Patent No.:** **US D896,702 S**

(45) **Date of Patent:** **** Sep. 22, 2020**

(54) **VEHICLE AND/OR REPLICA**

(74) *Attorney, Agent, or Firm* — Arent Fox, LLP

(71) Applicant: **HONDA MOTOR CO., LTD.**, Tokyo (JP)

(57) **CLAIM**

The ornamental design for a vehicle and/or replica, as shown and described.

(72) Inventors: **Erik Dunshee**, Long Beach, CA (US); **Asao Itaya**, Irvine, CA (US); **Eric Chin**, Irvine, CA (US); **Takao Mikami**, Nerima Tokyo (JP)

DESCRIPTION

(73) Assignee: **HONDA MOTOR CO., LTD.**, Tokyo (JP)

FIG. 1 is a right side view of a first embodiment of a vehicle and/or replica showing our new design; FIG. 2 is a front view of the design shown in FIG. 1; FIG. 3 is a left side view of the design shown in FIG. 1; FIG. 4 is a rear view of the design shown in FIG. 1; FIG. 5 is a top view of the design shown in FIG. 1; FIG. 6 is a bottom view of the design shown in FIG. 1; FIG. 7 is a front right perspective view of the design shown in FIG. 1; FIG. 8 is a front left perspective view of the design shown in FIG. 1; FIG. 9 is a rear left perspective of the design shown in FIG. 1;

(**) Term: **15 Years**

(21) Appl. No.: **29/653,903**

(22) Filed: **Jun. 19, 2018**

(51) **LOC (12) Cl.** **12-08**

(52) **U.S. Cl.**
USPC **D12/87**

(58) **Field of Classification Search**
USPC D12/87, 86, 107, 110, 1, 3, 4, 14, 16
(Continued)

FIG. 10 is a rear right perspective view of the design shown in FIG. 1; FIG. 11 is a right side view of a second embodiment of a vehicle and/or replica showing our new design; FIG. 12 is a front view of the design shown in FIG. 11; FIG. 13 is a left side view of the design shown in FIG. 11; FIG. 14 is a rear view of the design shown in FIG. 11; FIG. 15 is a top view of the design shown in FIG. 11; FIG. 16 is a bottom view of the design shown in FIG. 11; FIG. 17 is a front right perspective view of the design shown in FIG. 11; FIG. 18 is a front left perspective view of the design shown in FIG. 11; FIG. 19 is a rear left perspective of the design shown in FIG. 11; and, FIG. 20 is a rear right perspective view of the design shown in FIG. 11.

(56) **References Cited**

U.S. PATENT DOCUMENTS

D555,036 S * 11/2007 Eck D12/87
D592,998 S * 5/2009 Woodard, Jr. D12/14
(Continued)

OTHER PUBLICATIONS

"Introducing the 2019 Honda Talon," The Honda Side by Side Club!, <https://hondasxs.com/threads/introducing-the-2019-honda-talon.14000/>, accessed Jul. 16, 2018.

Primary Examiner — Michelle E. Wilson

Assistant Examiner — Clese Moore, Jr.

The broken lines shown in the figures are included for the purpose of illustrating portions of the vehicle and/or replica and form no part of the claimed design.

1 Claim, 20 Drawing Sheets

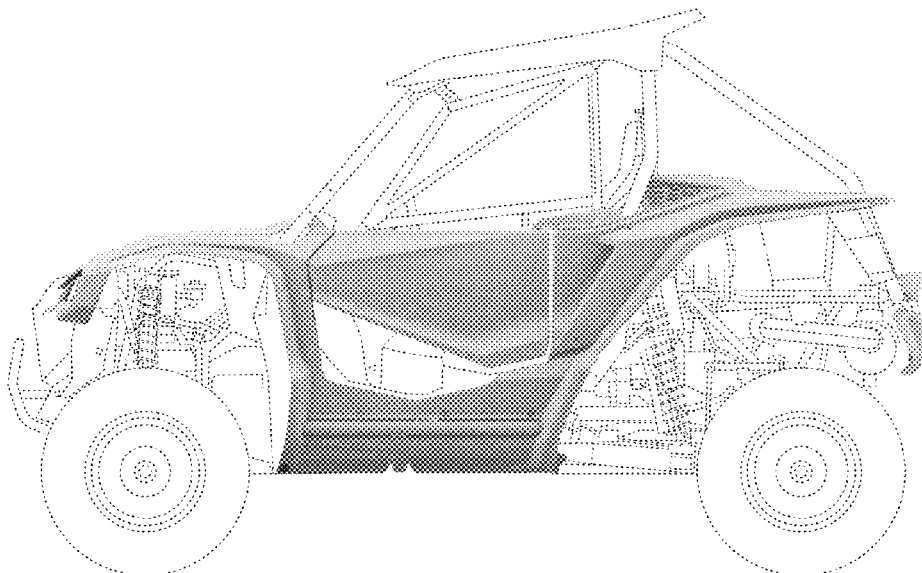

- (58) **Field of Classification Search**
CPC .. B60G 2300/07; B62D 21/183; B62D 23/00;
B62D 25/00

See application file for complete search history.

- (56) **References Cited**

U.S. PATENT DOCUMENTS

D622,631	S	*	8/2010	Lai	D12/87
D625,662	S	*	10/2010	Li	D12/87
D631,793	S	*	2/2011	Sanschagrin	D12/14
D641,288	S	*	7/2011	Sun	D12/87
D642,493	S	*	8/2011	Goebert	D12/87
D650,311	S	*	12/2011	Bracy	D12/87
D662,855	S	*	7/2012	Wang	D12/87
D701,469	S	*	3/2014	Lai	D12/87
D703,102	S	*	4/2014	Eck	D12/87
D712,309	S	*	9/2014	Wu	D12/14
D716,694	S	*	11/2014	Higashikawa	D12/14
D735,077	S	*	7/2015	Sato	D12/87
D737,724	S	*	9/2015	Schroeder	D12/14
D756,845	S	*	5/2016	Flores	D12/14
D762,522	S	*	8/2016	Kinoshita	D12/87
D772,755	S	*	11/2016	Tandrup	D12/14
D785,502	S	*	5/2017	Dunshee	D12/14
D804,993	S	*	12/2017	Eck	D12/87
D814,347	S	*	4/2018	Kushita	D12/14
D835,545	S	*	12/2018	Hanten	D12/87

* cited by examiner

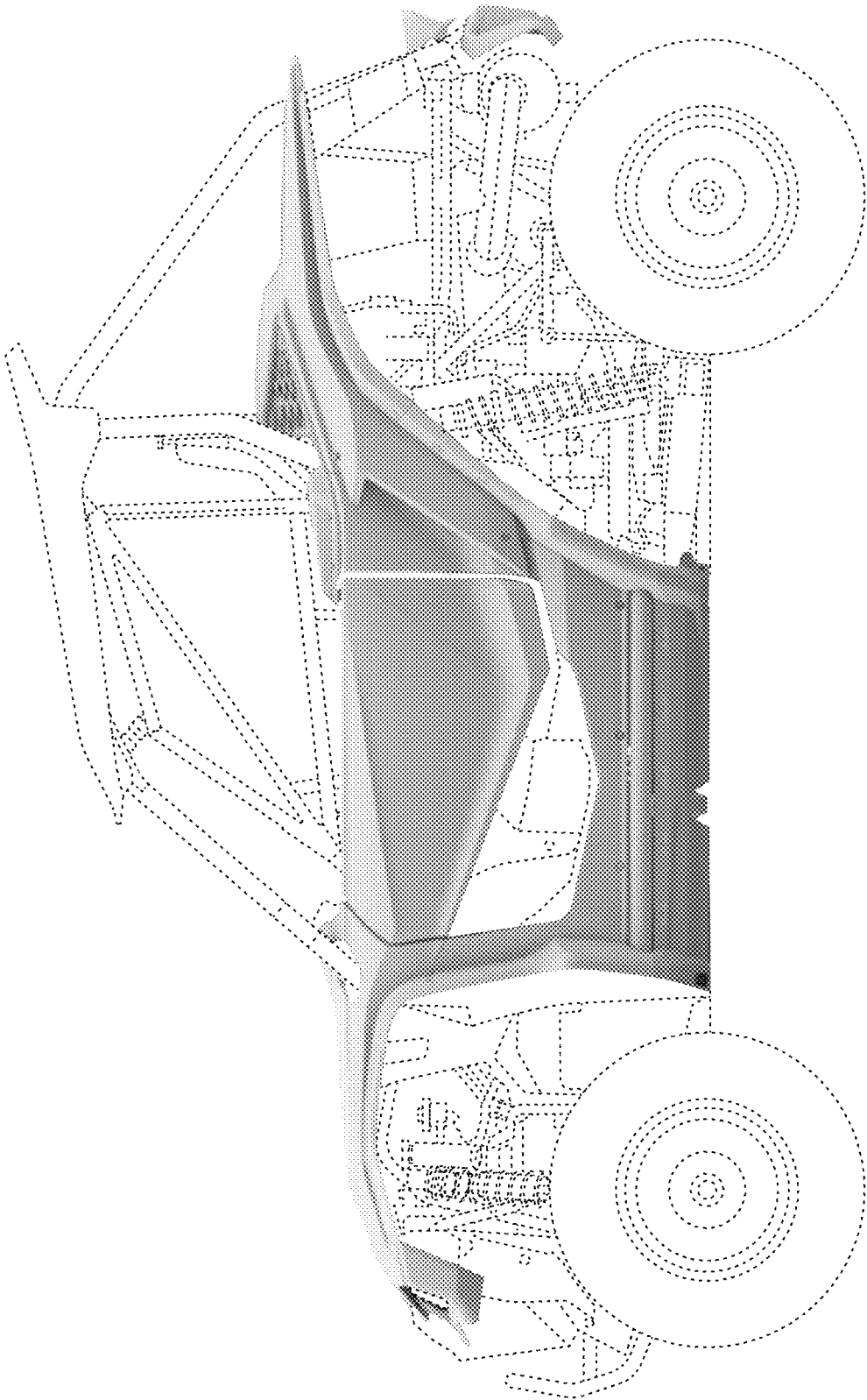

FIG. 1

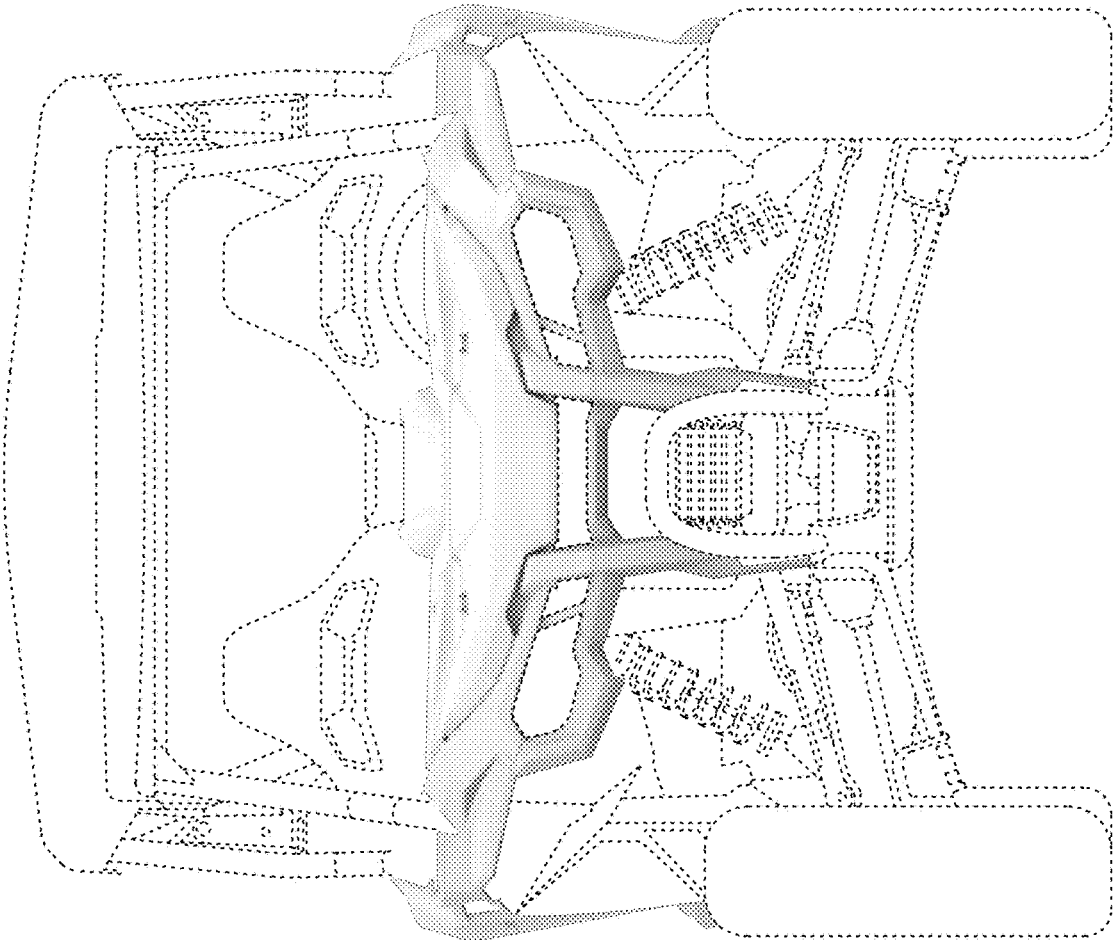

FIG. 2

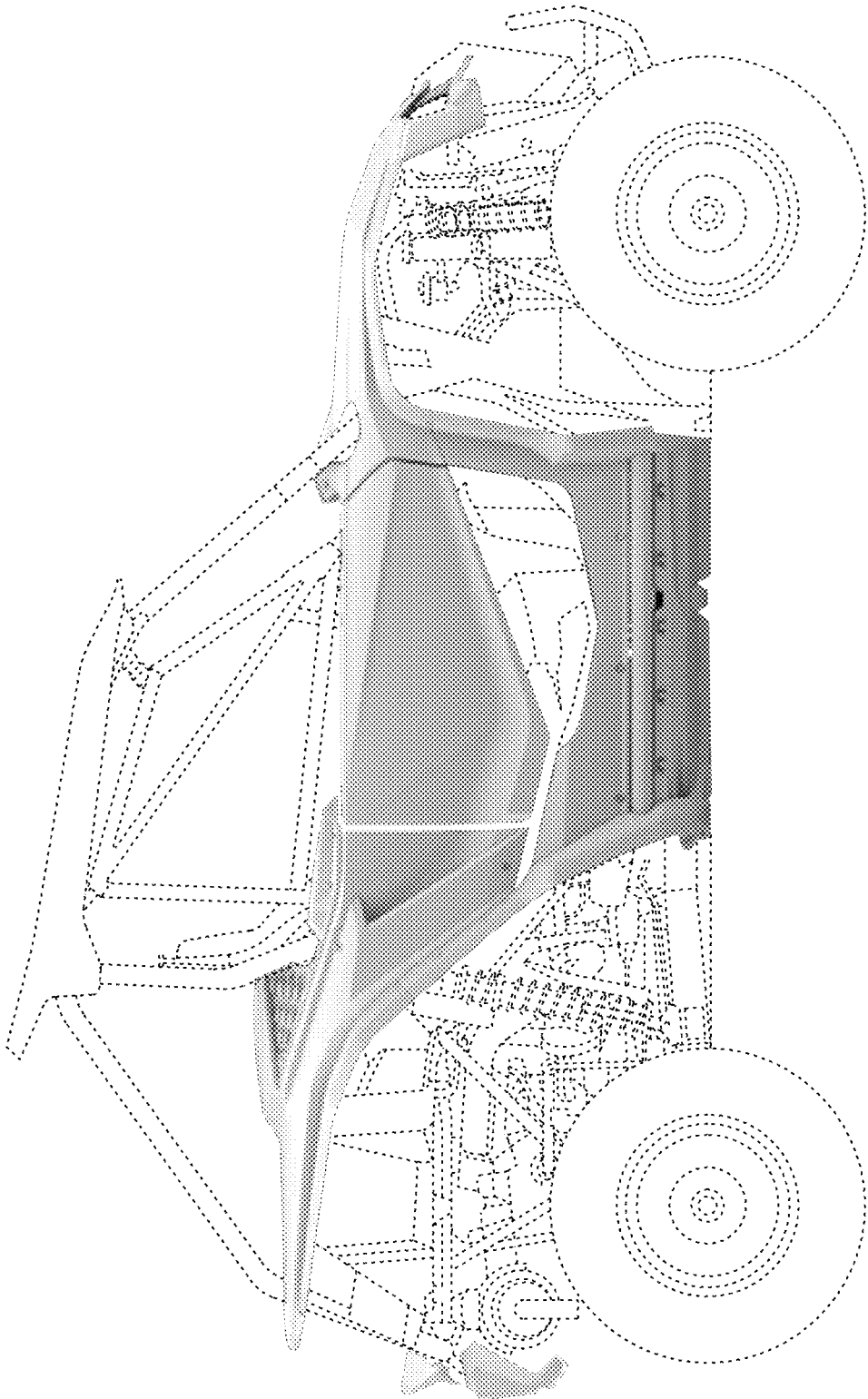

FIG. 3

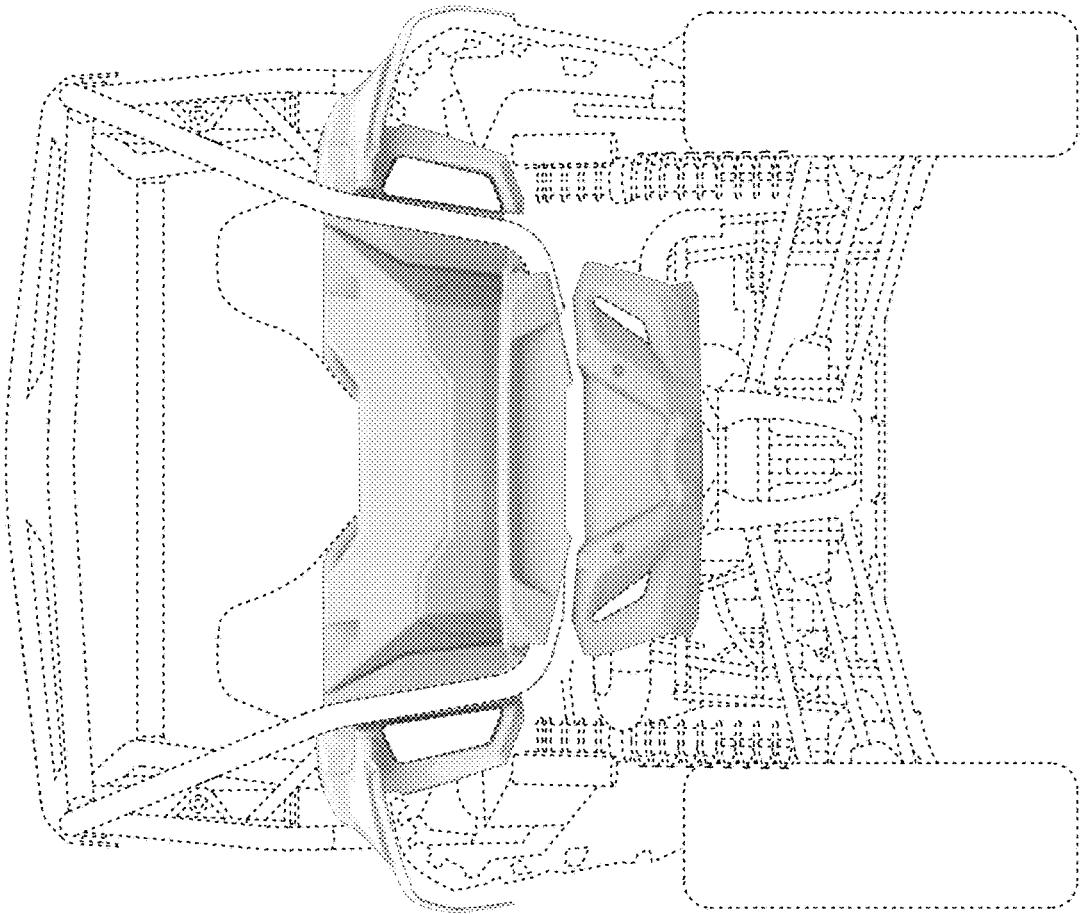

FIG. 4

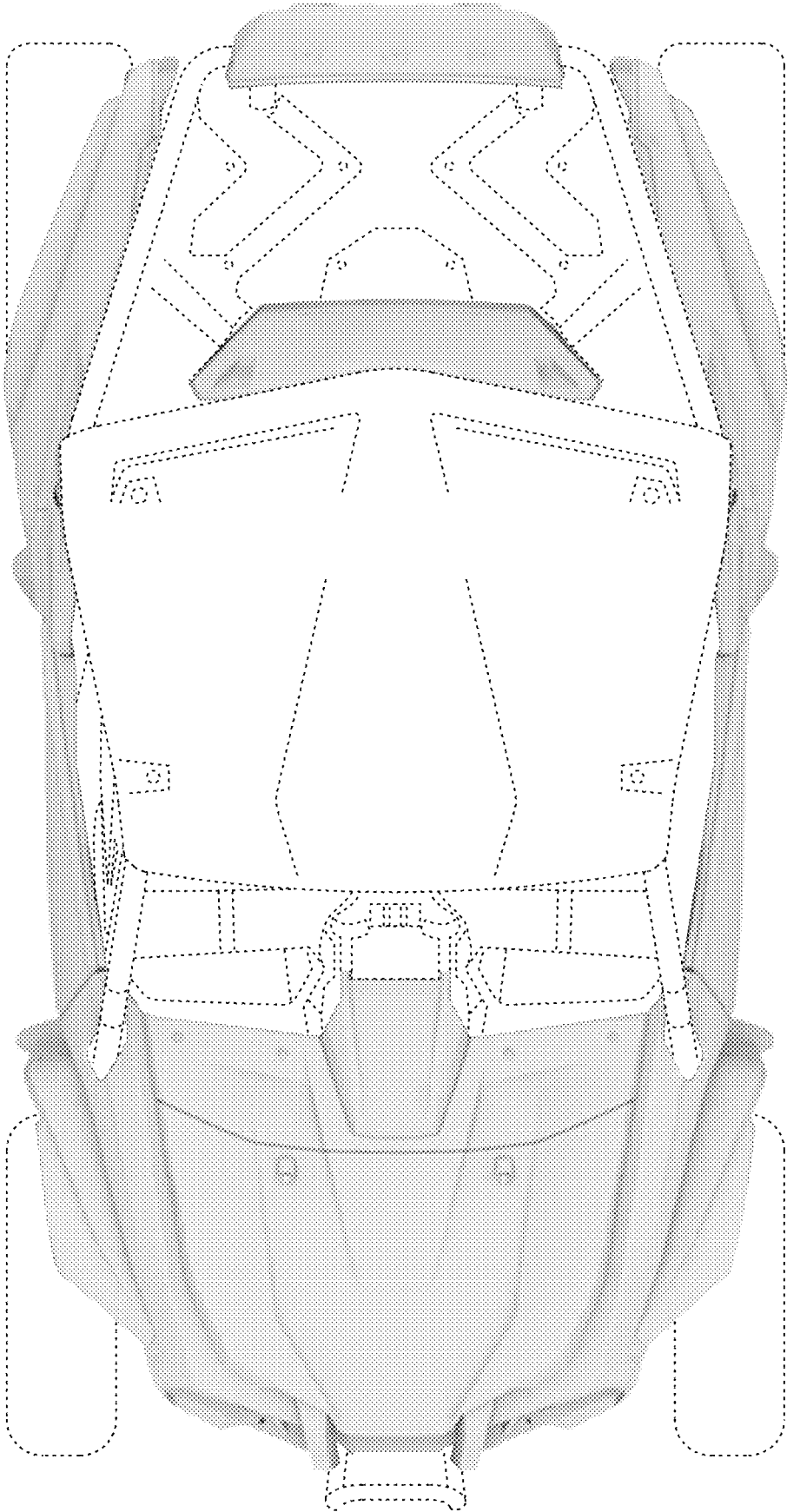

FIG. 5

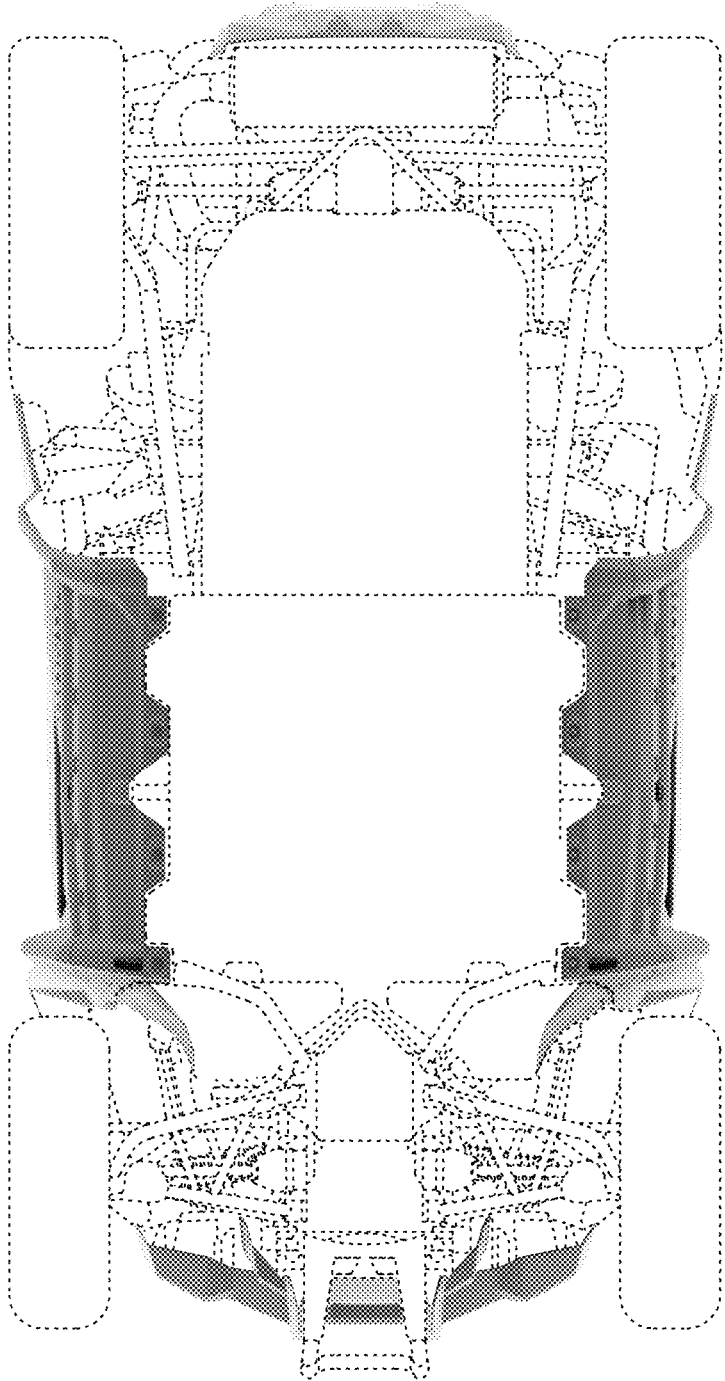

FIG. 6

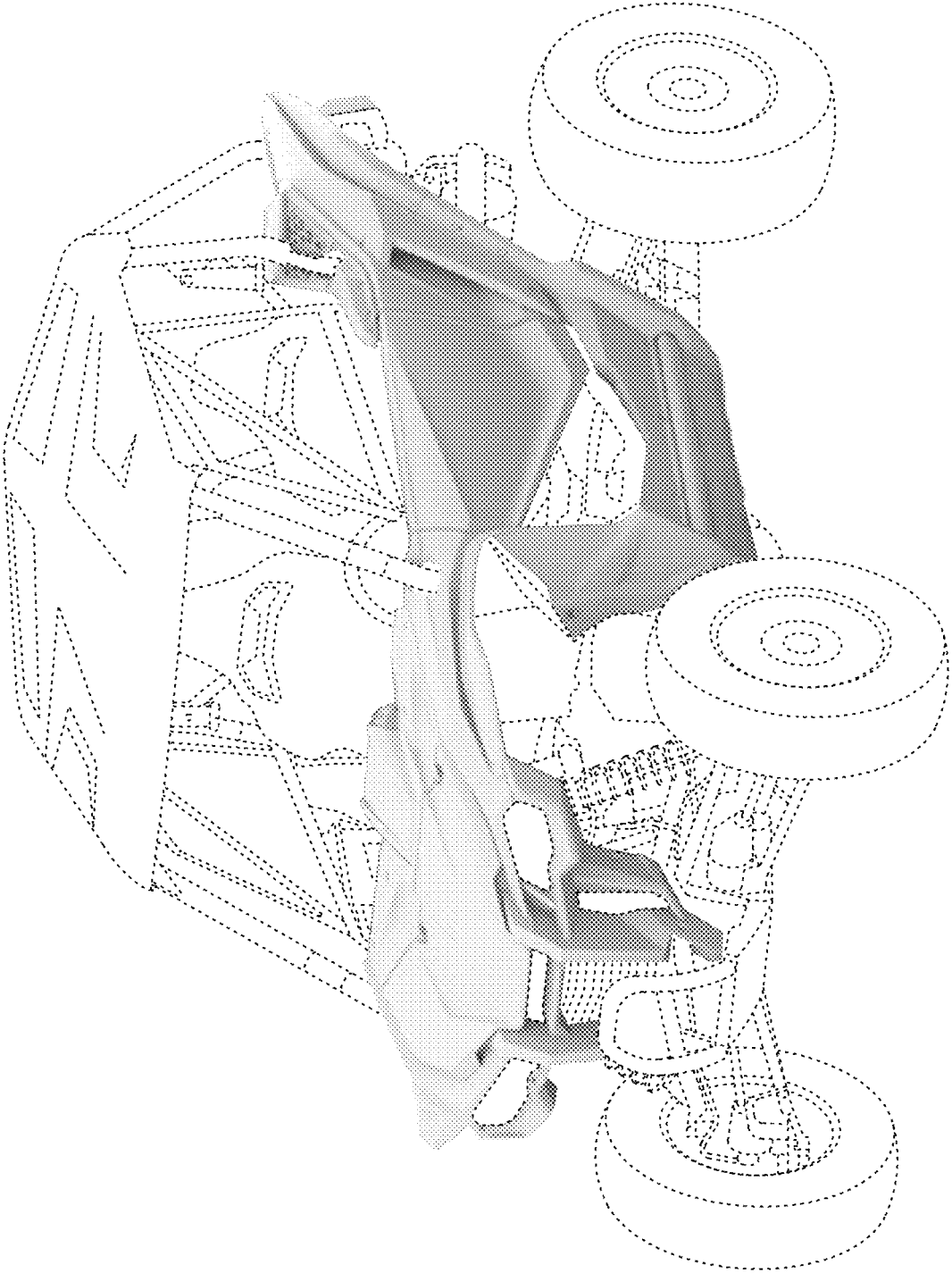

FIG. 7

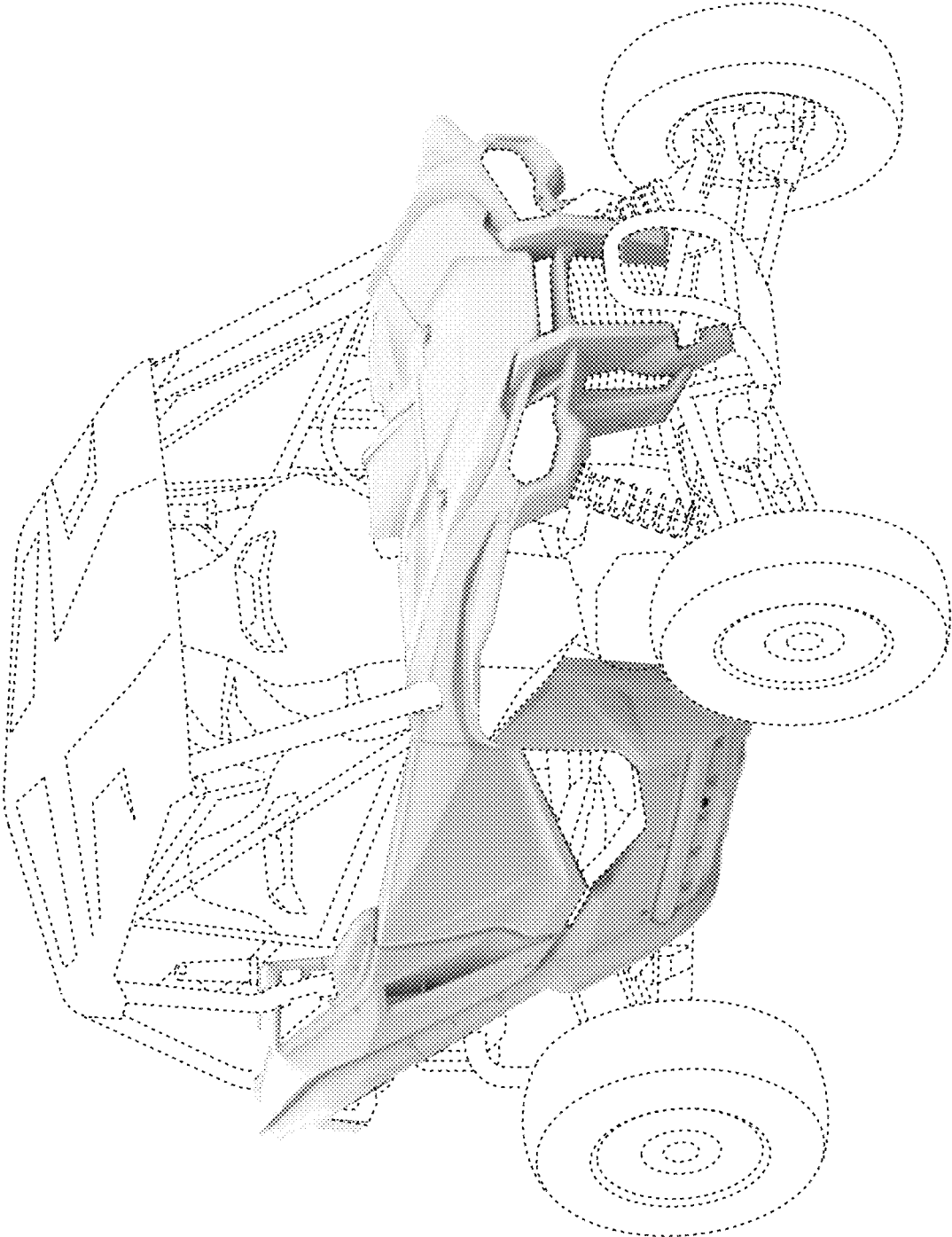

FIG. 8

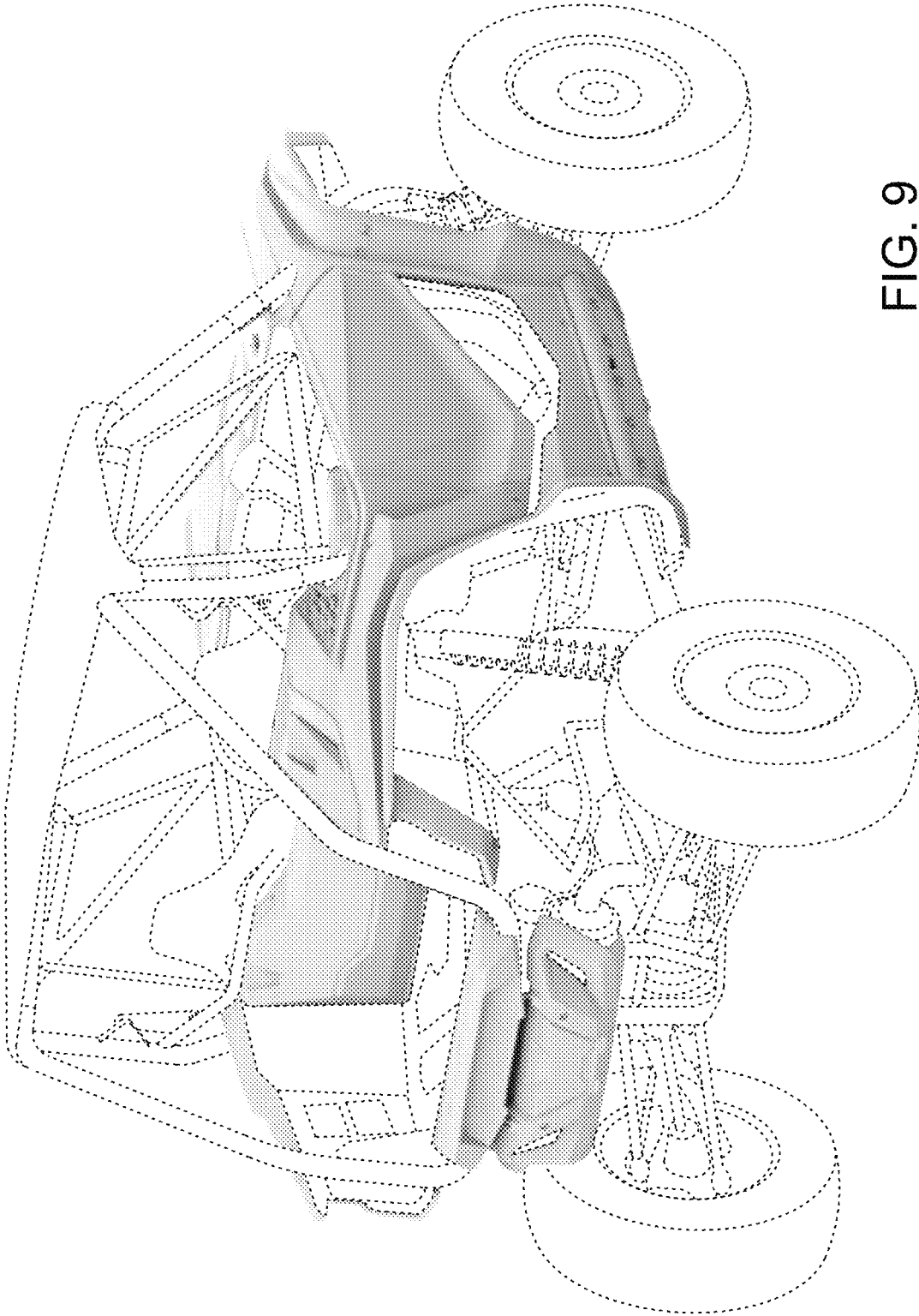

FIG. 9

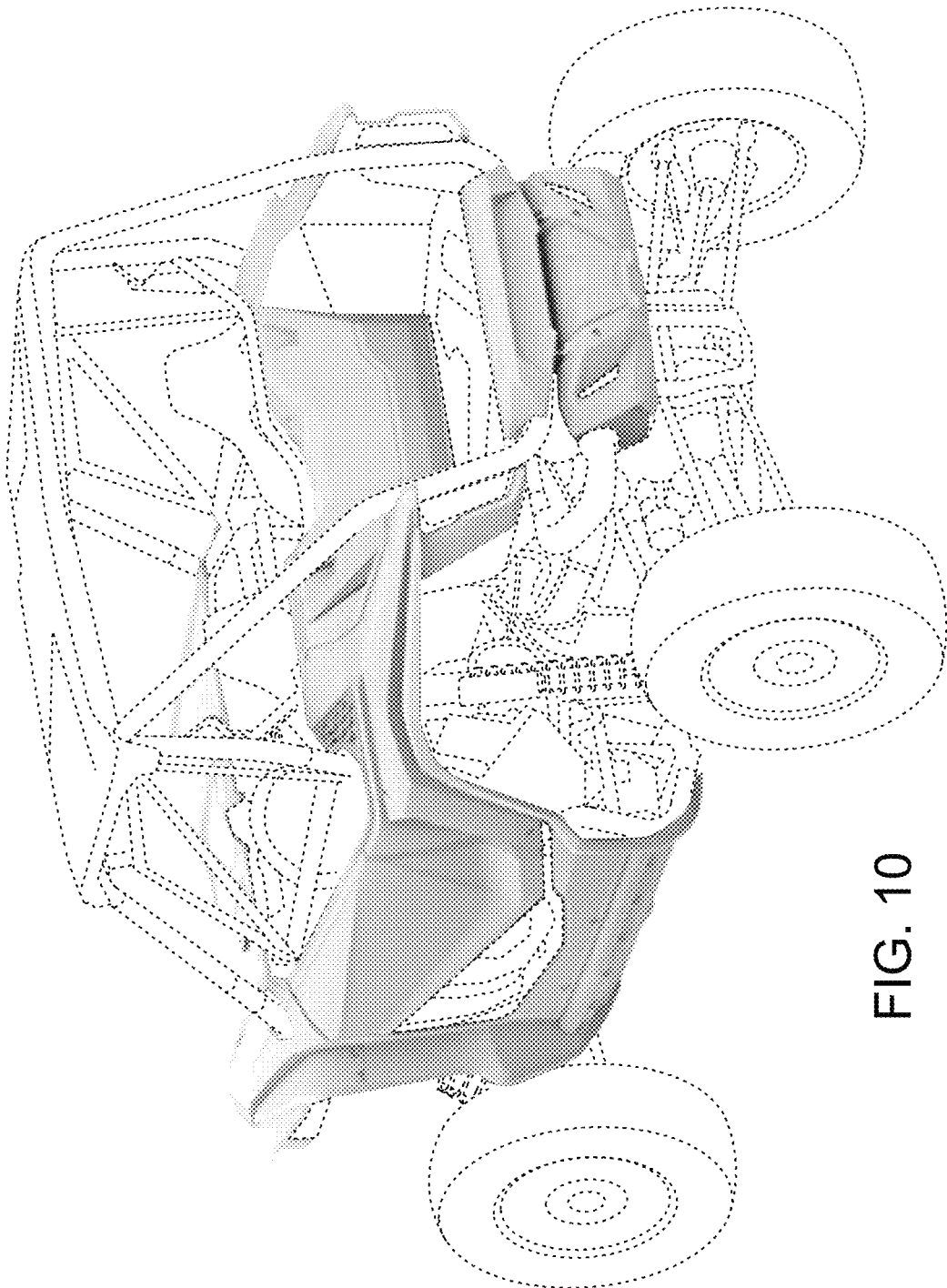

FIG. 10

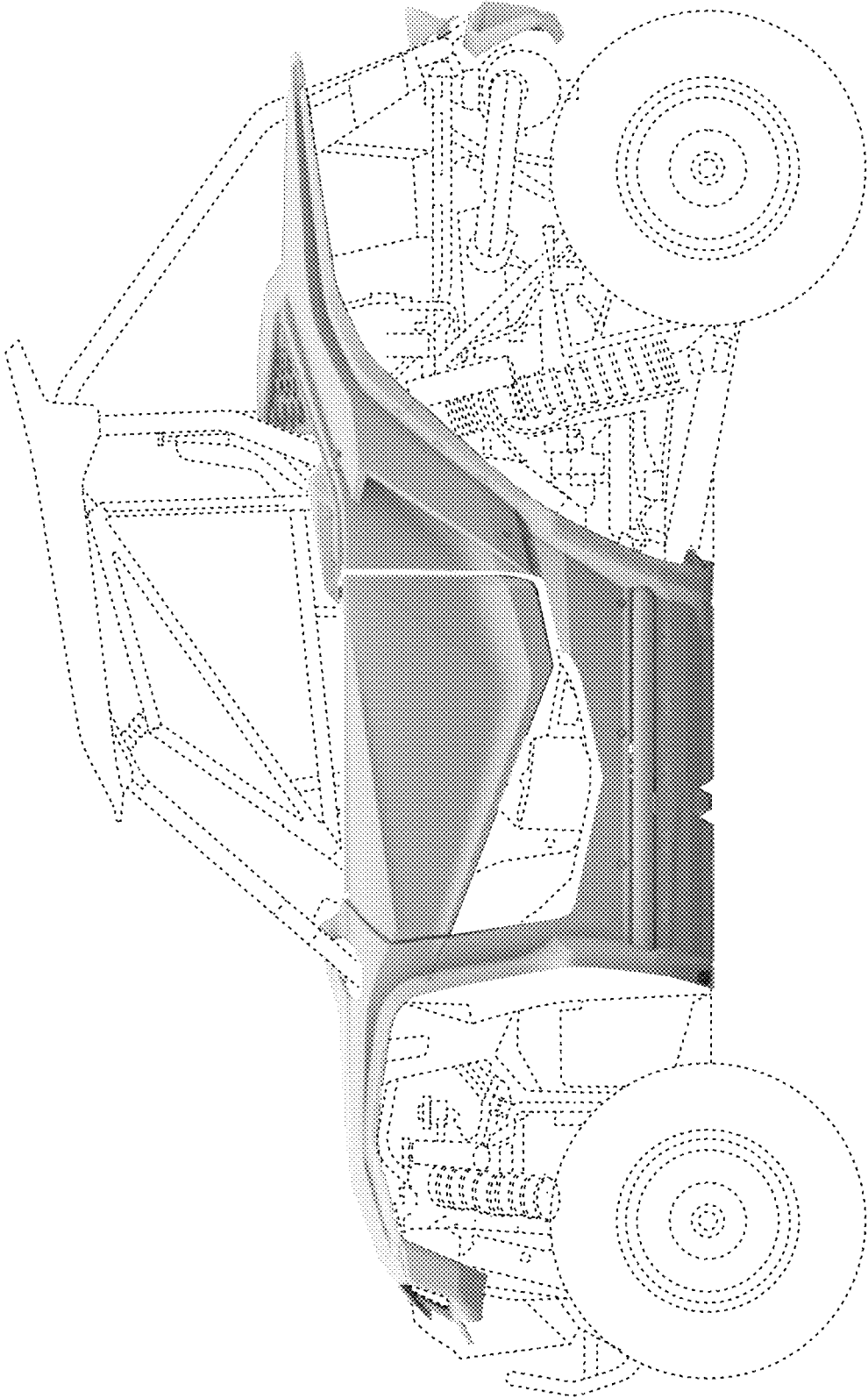

FIGURE 11

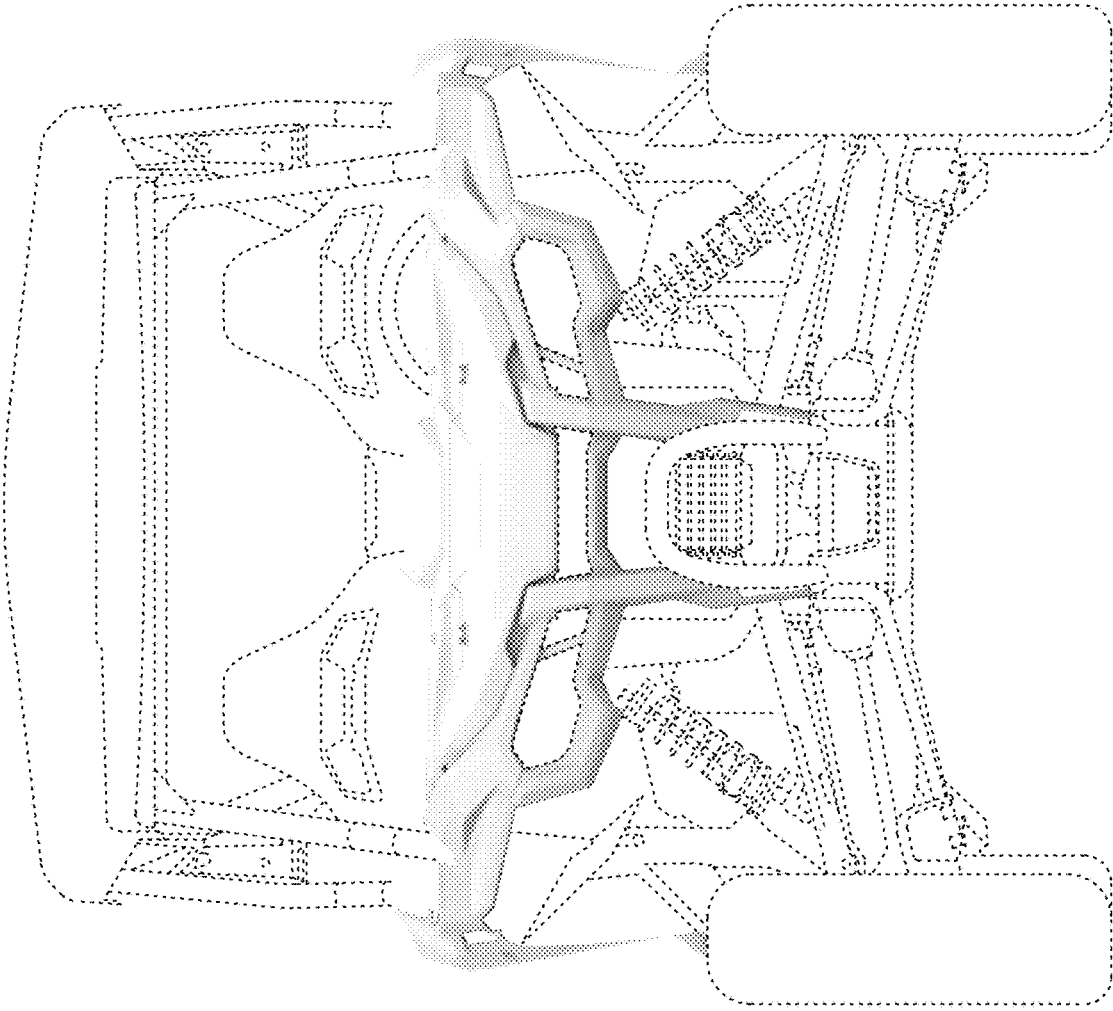

FIGURE 12

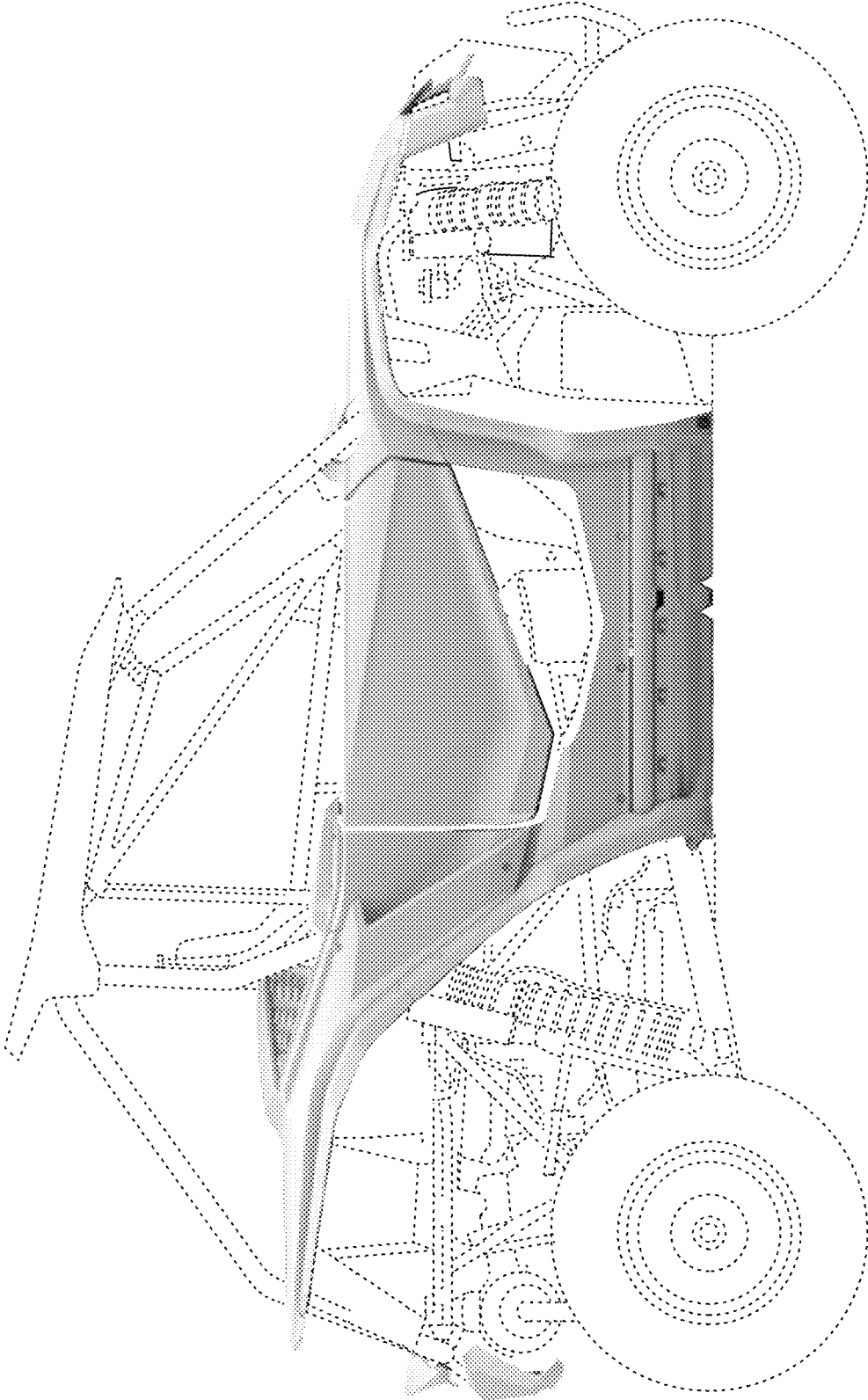

FIGURE 13

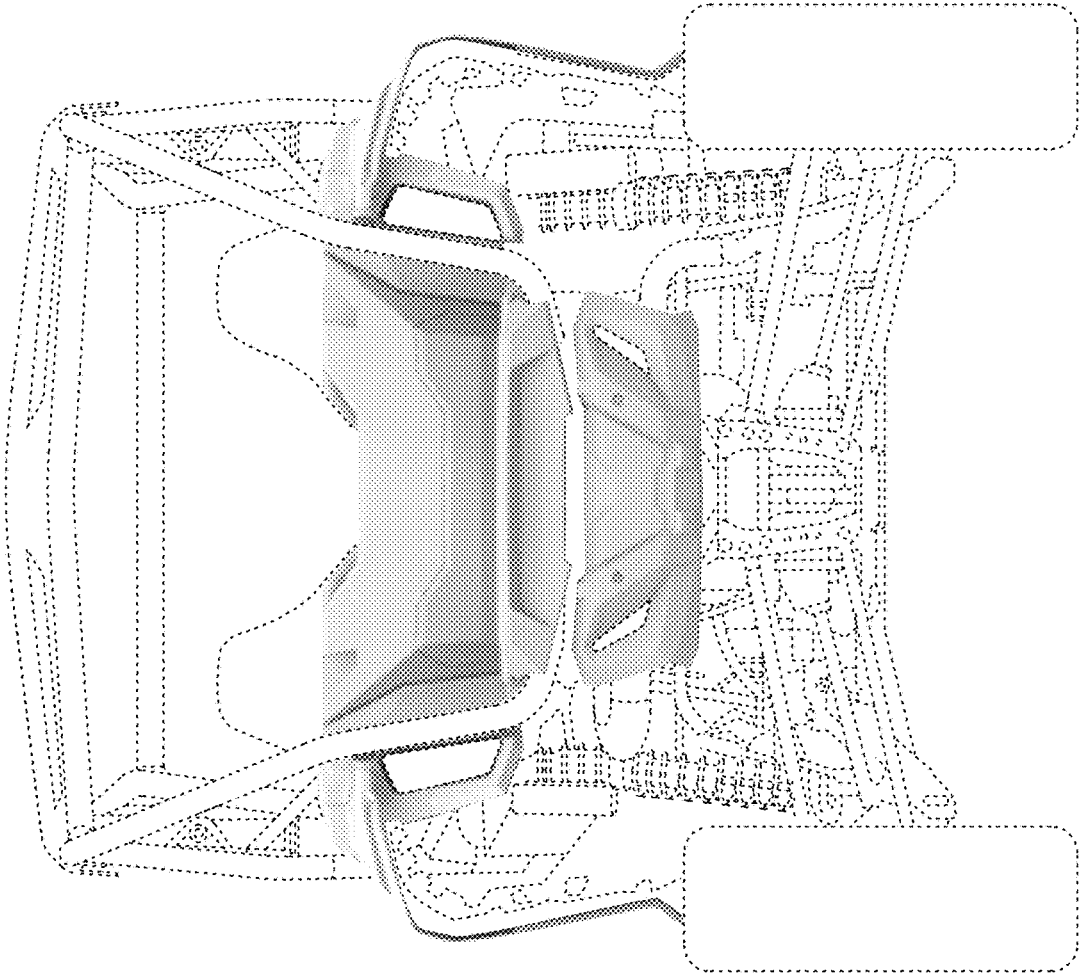

FIGURE 14

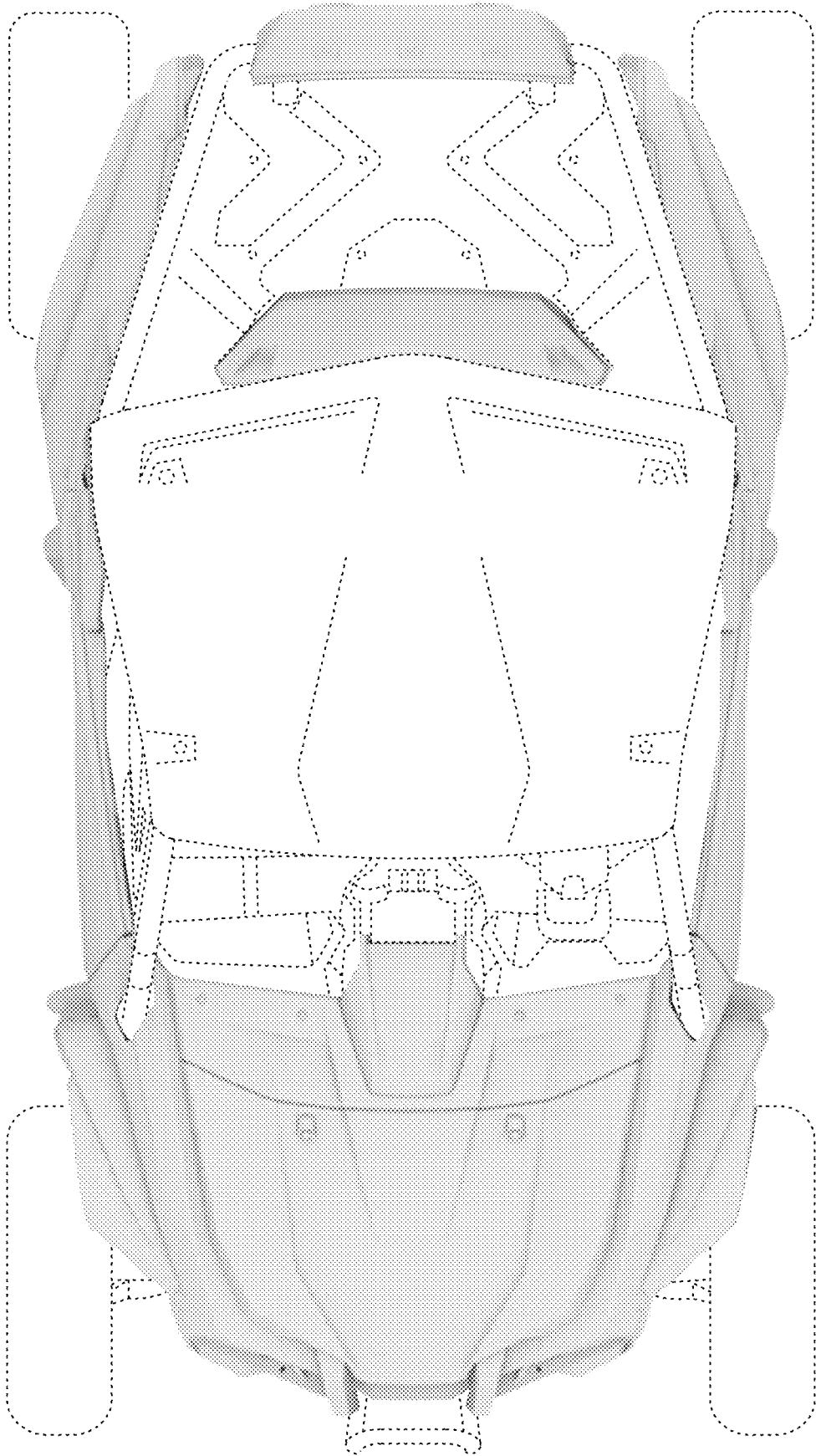

FIGURE 15

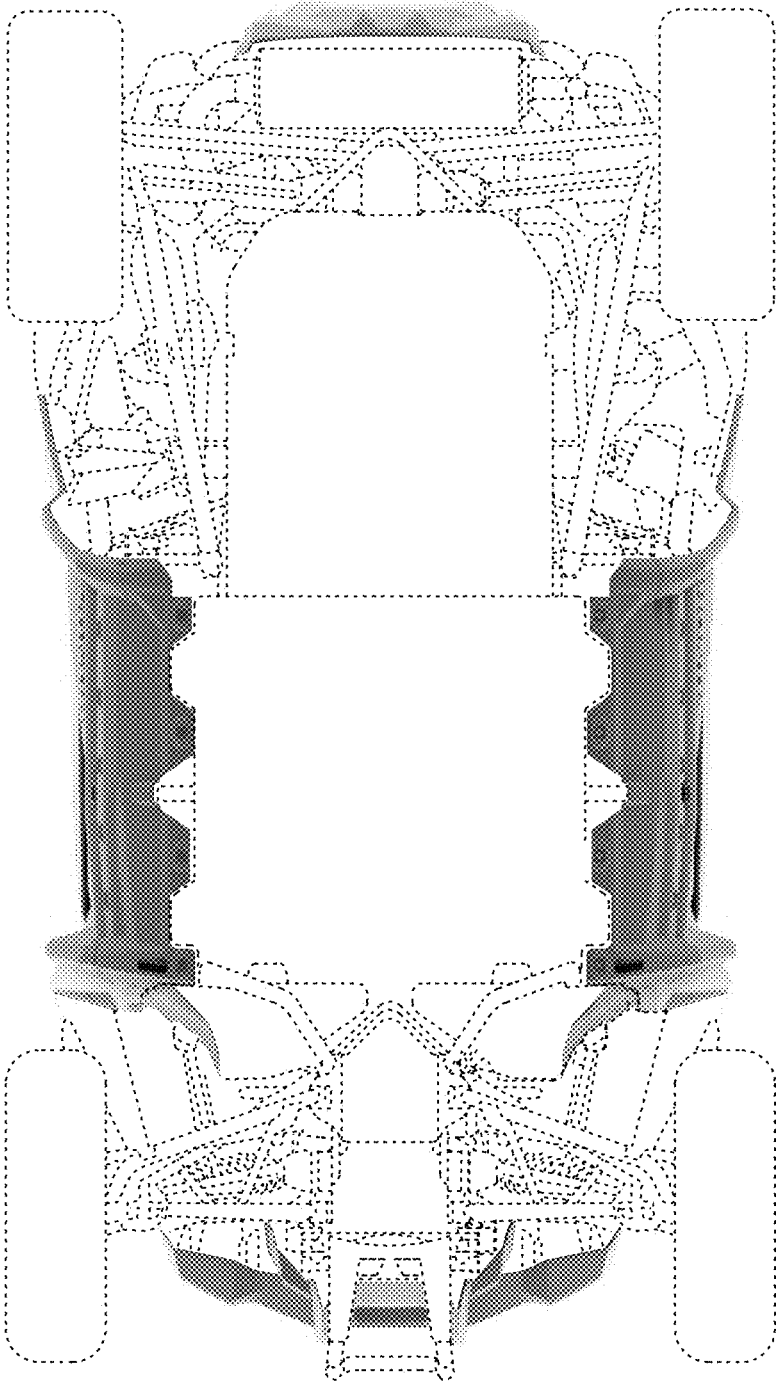

FIGURE 16

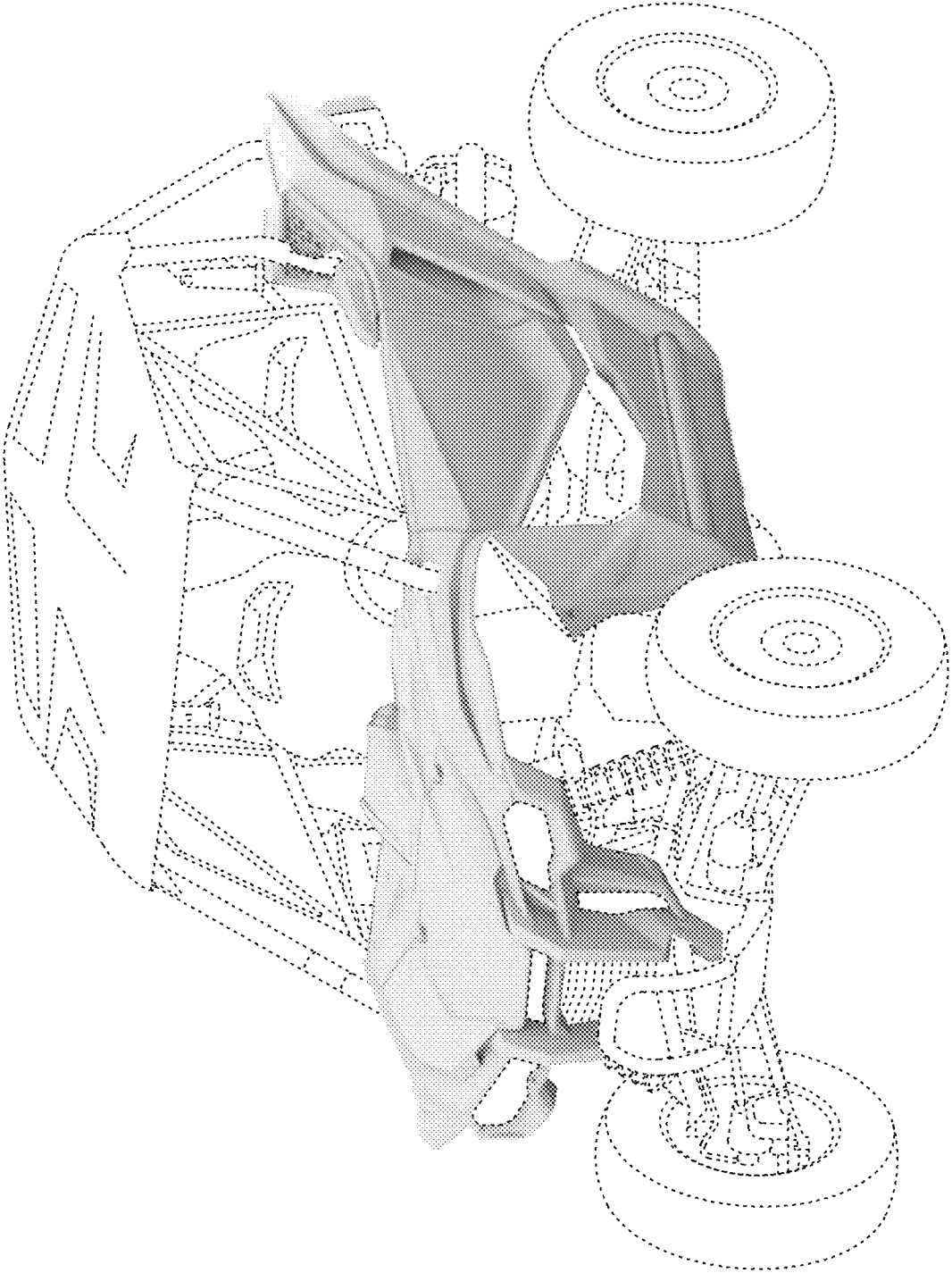

FIGURE 17

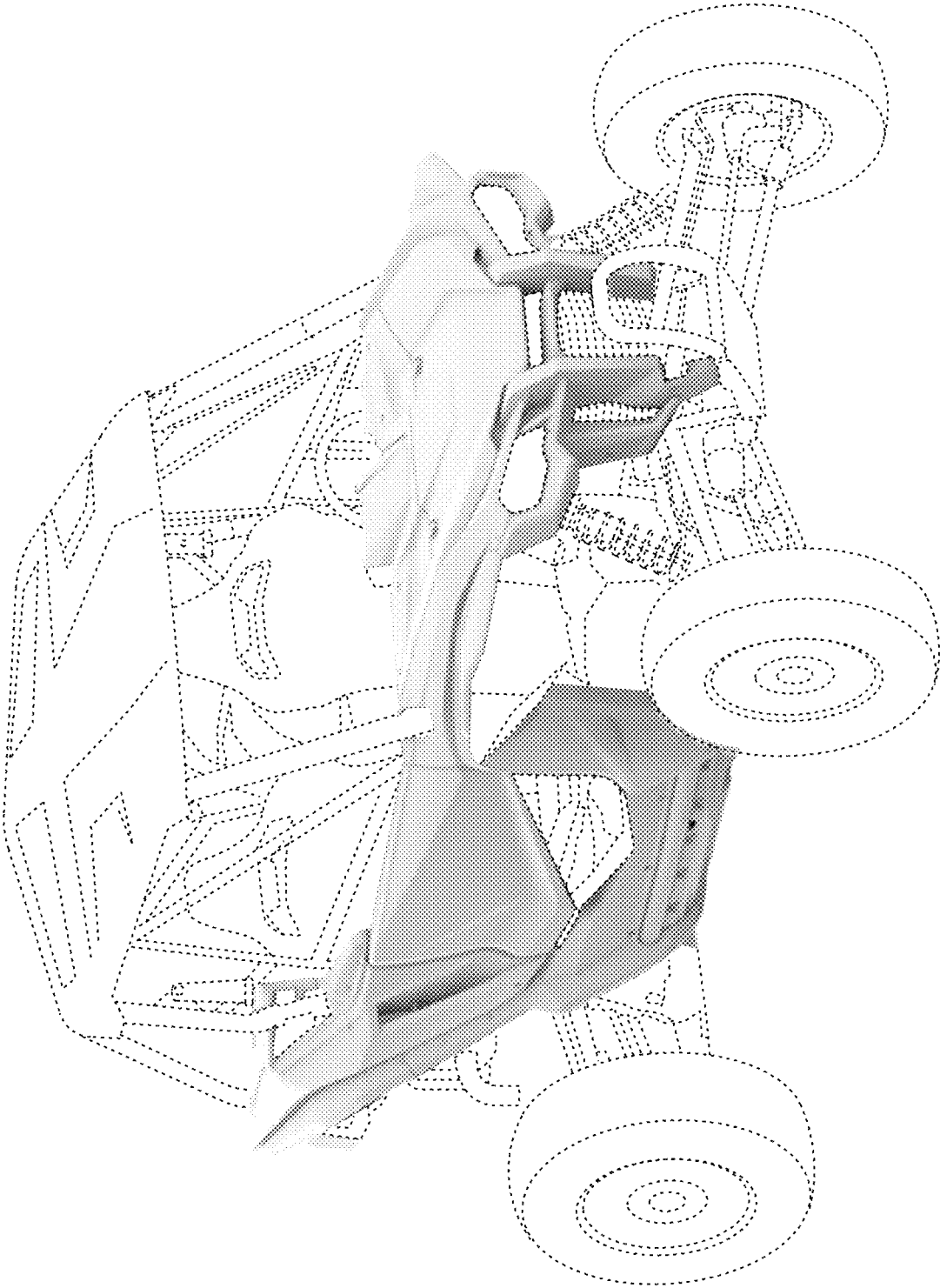

FIGURE 18

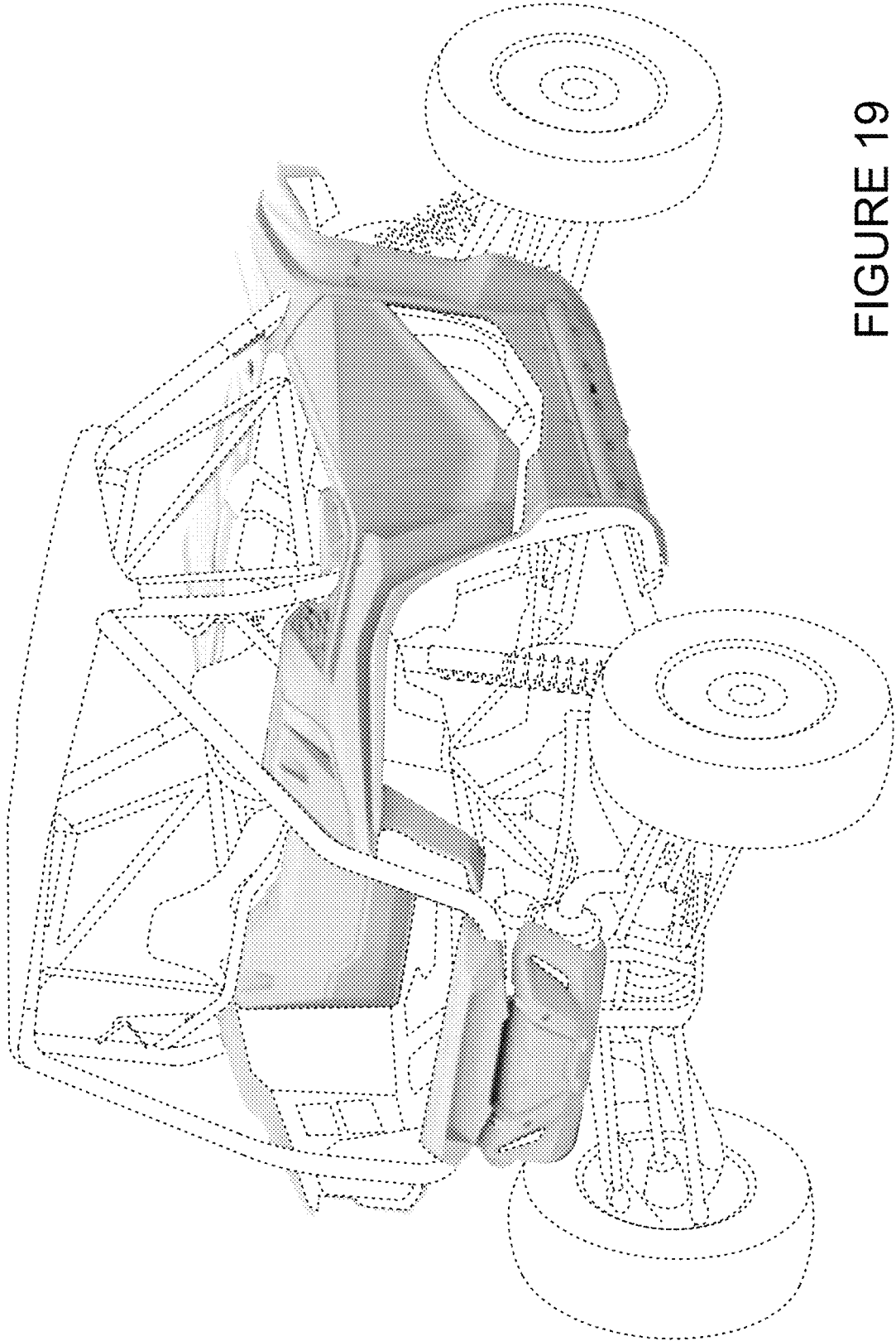

FIGURE 19

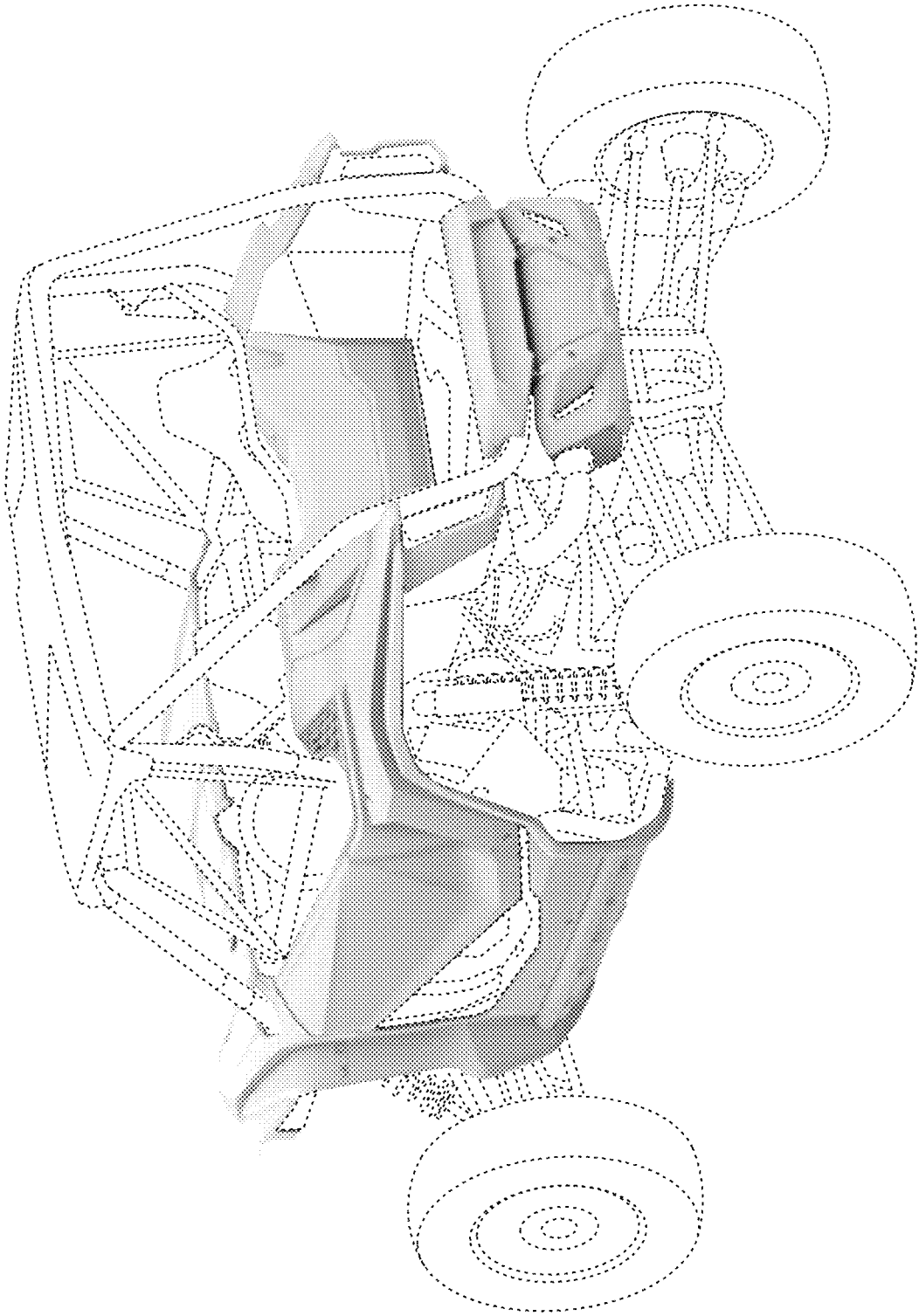

FIGURE 20