

PCT

WORLD INTELLECTUAL PROPERTY ORGANIZATION
International Bureau



INTERNATIONAL APPLICATION PUBLISHED UNDER THE PATENT COOPERATION TREATY (PCT)

<p>(51) International Patent Classification ⁶ : A61B 17/06, 17/04</p>	<p>A1</p>	<p>(11) International Publication Number: WO 96/03925 (43) International Publication Date: 15 February 1996 (15.02.96)</p>
<p>(21) International Application Number: PCT/US95/07270 (22) International Filing Date: 7 June 1995 (07.06.95) (30) Priority Data: 08/286,878 5 August 1994 (05.08.94) US (71) Applicant: ORIGIN MEDSYSTEMS, INC. [US/US]; 135 Constitution Drive, Menlo Park, CA 94025 (US). (72) Inventors: BOLDUC, Lee; 761 - 1/2 Palo Alto Avenue, Mountain View, CA 94041 (US). KRAMER, Thomas, A.; 1149 Orange Avenue, San Carlos, CA 94070 (US). HODGES, Brian, A.; 360 Sunfish Court, Foster City, CA 94404 (US). McCOY, Tim; 2 Cottage Lane, San Carlos, CA 94070 (US). LUNSFORD, John; 3378 Brittan Avenue #15, San Carlos, CA 94070 (US). (74) Agent: FULWIDER PATTEN LEE & UTECHT; 10th floor, 10877 Wilshire Boulevard, Los Angeles, CA 90024 (US).</p>		<p>(81) Designated States: CA, JP, European patent (AT, BE, CH, DE, DK, ES, FR, GB, GR, IE, IT, LU, MC, NL, PT, SE). Published <i>With international search report. Before the expiration of the time limit for amending the claims and to be republished in the event of the receipt of amendments.</i></p>

(54) Title: SURGICAL HELICAL FASTENER WITH APPLICATOR

(57) Abstract

A helical fastener (10) having a high retentive surface area is provided and has a first end (22) for enhancing penetration into tissue (25) and a second end (26) comprising a coil sectioning a diameter (18) of the fastener (10) for receiving longitudinal and rotational forces. The helical fasteners (10) are attached to body tissue (25) by a fastener applicator (12) having a proximal portion (28) comprising a handle (30) and an actuator (32) and an elongate distal portion (34) for housing a plurality of fasteners (10). A transferring action of the actuator (32) provides longitudinal and rotational movement of the fasteners (10) out of the distal portion (34) and into body tissue (25).

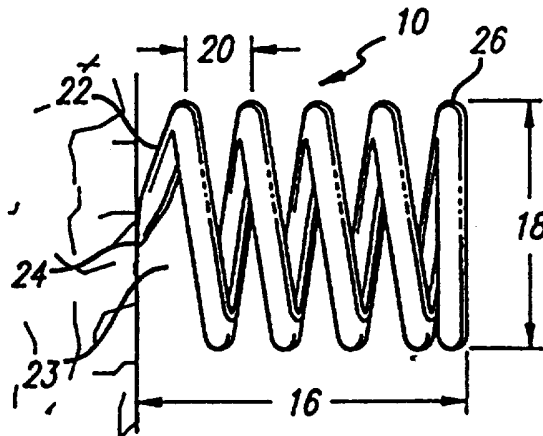

FOR THE PURPOSES OF INFORMATION ONLY

Codes used to identify States party to the PCT on the front pages of pamphlets publishing international applications under the PCT.

AT	Austria	GB	United Kingdom	MR	Mauritania
AU	Australia	GE	Georgia	MW	Malawi
BB	Barbados	GN	Guinea	NE	Niger
BE	Belgium	GR	Greece	NL	Netherlands
BF	Burkina Faso	HU	Hungary	NO	Norway
BG	Bulgaria	IE	Ireland	NZ	New Zealand
BJ	Benin	IT	Italy	PL	Poland
BR	Brazil	JP	Japan	PT	Portugal
BY	Belarus	KE	Kenya	RO	Romania
CA	Canada	KG	Kyrgystan	RU	Russian Federation
CF	Central African Republic	KP	Democratic People's Republic of Korea	SD	Sudan
CG	Congo	KR	Republic of Korea	SE	Sweden
CH	Switzerland	KZ	Kazakhstan	SI	Slovenia
CI	Côte d'Ivoire	LI	Liechtenstein	SK	Slovakia
CM	Cameroon	LK	Sri Lanka	SN	Senegal
CN	China	LU	Luxembourg	TD	Chad
CS	Czechoslovakia	LV	Latvia	TG	Togo
CZ	Czech Republic	MC	Monaco	TJ	Tajikistan
DE	Germany	MD	Republic of Moldova	TT	Trinidad and Tobago
DK	Denmark	MG	Madagascar	UA	Ukraine
ES	Spain	ML	Mali	US	United States of America
FI	Finland	MN	Mongolia	UZ	Uzbekistan
FR	France			VN	Viet Nam
GA	Gabon				

SURGICAL HELICAL FASTENER WITH APPLICATOR

BACKGROUND OF THE INVENTION

This invention relates to surgical fasteners and their associated applicators, and more particularly, surgically fastening material to tissue.

Fasteners have been used surgically to eliminate the need for suturing, which is both time consuming and inconvenient. In many applications the surgeon can use a stapler apparatus, i.e., a fastener implanting device loaded with surgical fasteners to accomplish in a few seconds what would have taken many minutes to perform by suturing. This reduces blood loss and trauma to the patient.

Conventional surgical fasteners have been in the form of ordinary metal staples, which are bent by the delivery apparatus to hook together body tissue. Typically, conventional staples comprise a pair of legs joined together at one end by a crown. The crown may be a straight member connecting the legs or may form an apex. Moreover, the legs may extend substantially perpendicular from the crown or at some angle therefrom. Irrespective of the particular configuration, however, conventional staples are designed so that they may be deformed to hold body tissue.

Accordingly, the stapler applicators have conventionally embodied structure functioning to project the conventional staple into tissue as well as to deform the staple so that it is retained against the tissue. Generally speaking, typical applicators include an anvil cooperating with means to eject the conventional staple from the applicator. In some applications, access to the body tissue from two opposite directions is available and the anvil can operate to deform the legs of the staple after they have passed through the body tissue. In applications where access to the tissue is from only one direction,

-2-

the anvil may deform the crown of the conventional staple so that its legs will project into the body tissue in a fashion so as to hold the staple against the tissue.

5 Since conventional staples require deformation and must cooperate with applicators having an anvil or other means to deform the staples, conventional applicators typically comprise complex structures and can be prohibitively expensive.
10 Conventional applicators must embody structure functioning to not only eject the fasteners but to do so in a manner so that the fastener deforms properly and timely.

 In some applications, conventional
15 applicators must be equipped with structure functioning to move the anvil into and out of position so that when the fastener is ejected from the applicator, the anvil is properly positioned and once fastener deformation is complete, moves out of position, thereby allowing the
20 process to be repeated. Moreover, the anvil must be formed into a proper configuration so that fastener deformation can be repeated accurately. Further, the force between the fastener and the anvil must be controlled so that repeated deformation is
25 accomplished. The objectives of many inventions in this field have been to accomplish these goals by the simple manipulation of a single lever. It is to be appreciated, therefore, that the fastener applicators have become complex and expensive instruments.

30 Two part fasteners have also been conventionally utilized, where a barbed staple is used in conjunction with a retaining piece to hold the staple in place. Typically, the two part staple comprises a crown or backspan and two barbed prongs
35 which are engaged and locked into a separate retainer piece. In use, the staple is pressed into the body tissue so that the barbs penetrate the tissue and

emerge from the other side where they are then locked into the retainer piece. Retainers prevent the staple from working loose from the tissue. The two piece fasteners cannot be unlocked and are not removable.

5 Like other conventional applications, however, the two piece fasteners require the staple delivery apparatus to have access to both sides of the tissue. Thus, as with the other conventional applications, two piece fasteners are limited since
10 they cannot be used where access to tissue is from one direction only.

In those situations where access to body tissues is limited to one direction, as in grafting procedures, deformable surgical fasteners have been
15 conventionally employed. As mentioned previously, however, the applicators commonly used in these situations embody an anvil cooperating with a fastener to deform it and consequently, tend to be of a complex design.

20 Some advancements have been made in this area so that applicators functioning to attach grafts to tissue, for instance, are not required to embody an anvil and may, therefore, have a more simple design. In particular, it has been suggested in the art to
25 employ fasteners with barbs, thereby eliminating the need for deforming the fastener. These fasteners are limited, however, since the path created in the graft and tissue by the barbs as the fastener is pressed into the graft and tissue may allow the fastener to loosen
30 its grip or to entirely back out of engagement. Moreover, due to their sole reliance upon barbs to retain tissue, the barb fasteners are further limited in that they may not have a great enough retentive surface area for securely holding tissue in place.

35 To circumvent or overcome the problems and limitations associated with conventional fasteners and applicators, a simple applicator that dispenses a

surgical fastener having high surface area for retentive contact with tissue and that can be delivered into body tissue from one direction may be employed. The present invention embodies these characteristics.

5

SUMMARY OF THE INVENTION

The invention includes a surgical fastener and an applicator used in delivering the fastener into body tissue. The fastener and applicator of the present invention may be used in a number of medical
10 procedures including ligating tissue, hernia mesh repair, bladder neck suspension, and in conjunction with implant drug delivery systems or procedures involving positioning of surgical or implantable devices in a patient's body.

15

The preferred embodiment of the surgical fastener of the present invention is formed into the configuration of a continuous helical coil. The continuous helical coil is longitudinally collapsible and expandable. At the distal end of the helical
20 fastener is a point for enhancing penetration into tissue. The proximal end of the helical fastener has a T-bar which sections the diameter of the fastener, thereby providing a surface for receiving and transmitting longitudinal and rotational forces so that
25 the fastener may be driven into tissue by a corkscrew action. The pitch and length of the helical fastener may vary upon the application as can its diameter and configuration of the most proximal and distal coils comprising the fastener. Additionally, the material
30 selection and fastener stiffness may be selected with a particular application in mind.

35

In another embodiment of the surgical fastener, the fastener comprises a double continuous helical coil that is also longitudinally collapsible and expandable and may embody various configurations

-5-

depending upon the application. Moreover, the distal end of the double helical fastener comprises two points for enhancing penetration into tissue and its proximal end comprises a connector bar which connects the two
5 helixes as well as sections the diameter of the double helical fastener. In yet another embodiment, the surgical fastener further comprises a pivot post extending through the center of the fastener and operating to provide the fastener with a stable pivot.
10 In any of the embodiments, one or more barbs may be employed near the point to enhance anchoring characteristics.

A preferred embodiment of the fastener applicator of the present invention includes a proximal
15 portion and a distal portion. The proximal portion is preferably fabricated to be a "reusable" component and the distal portion a "disposable" component. Alternatively, both the distal and proximal portion can be made disposable. The distal portion is elongate and
20 embodies an outer tube housing an inner rotator, a lock clip/indicator and a load spring. The proximal portion includes a handle. In the preferred embodiment of the distal portion, a thread form comprising an interlock spring is provided within the outer tube. The rotator
25 includes a structure running longitudinally along its length that functions to receive the T-bar or connector bar of the fastener and in this way, the rotator may hold a plurality of fasteners. The load spring applies a force against the lock clip/indicator operating to
30 bias the plurality of springs distally within the outer tube and towards the nose piece. The thread form functions to engage the coils of the helical fasteners and when rotating the rotator, a fastener is driven from the distal end of the applicator. In other
35 embodiments of the applicator, the distal end has various other structures functioning to engage the coils of the fastener and to drive them from the distal

-6-

end of the applicator. In one other embodiment, the distal end comprises a nose piece protrusion for engaging the fastener.

5 In order to cause the rotator to rotate, the proximal portion of the applicator has a handle and an actuator cooperating with the rotator. In a preferred embodiment, the proximal portion of the applicator embodies a lever pivotally attached about a midpoint to the handle. A first end of the lever is configured to
10 be gripped by hand and a second end is adapted to engage a nut driver. The nut driver travels along a helical lead screw which is connected to the rotator. When the lever is squeezed by hand the nut driver travels along the lead screw causing it to rotate, and
15 through the connection of the lead screw to the rotator, the action of the lead screw causes the rotator to rotate.

Further, the lever comprises a midsection extension. Pivotaly attached to the midsection
20 extension of the lever is a spring loaded pawl adapted to releasably engage gear teeth formed in the interior of the handle. The spring loaded pawl prohibits the lever from backstroking until it has been completely depressed. Upon complete depression of the lever, the
25 pawl clears the gear teeth and the spring, biasing the pawl, rotates the pawl away from the teeth, thereby allowing the lever to return to its undepressed condition.

In another embodiment of the proximal portion
30 of the applicator, the lever is pivotally attached at a first end to the handle, the second end being adapted to engage the nut driver. Further, rather than embodying a spring loaded pawl, this alternate embodiment of the proximal portion includes a clutch
35 assembly or releasable connection between the lead screw and rotator and cooperating means to prohibit the

-7-

lever from backstroking until it has been completely depressed.

5 Other features and advantages of the present invention will become apparent from the following detailed description, taken in conjunction with the accompanying drawings, which illustrate, by way of example, the principals of the invention.

BRIEF DESCRIPTION OF THE DRAWINGS

FIGURE 1 depicts a perspective view of a fastener of the present invention, illustrating a side view of a helical fastener.

5 FIG. 1A depicts another perspective view of the fastener of the present invention, illustrating an end view of the helical fastener.

 FIG. 1B depicts a schematic view of a fastener of the present invention, illustrating a
10 substantially collapsed helical fastener with a relatively small gap that has been partially inserted into tissue.

 FIG. 1C depicts a schematic view of a fastener of the present invention, illustrating the
15 helical fastener depicted in FIG. 1B completely inserted into tissue.

 FIG. 1D depicts a schematic view of a fastener of the present invention, illustrating a
20 substantially collapsed helical fastener with a relatively large gap that has been partially inserted into the tissue.

 FIG. 1E depicts a schematic view of a fastener of the present invention, illustrating the
25 helical fastener depicted in FIG. 1D completely inserted into tissue.

FIG. 1F depicts a perspective view of another embodiment of the present invention, illustrating an end view of the helical fastener.

5 FIG. 2 depicts a perspective view of another embodiment of the present invention, illustrating a double helical fastener.

FIG. 2A is a front view of the double helical fastener of FIG. 2.

10 FIG. 2B is side view of the double helical fastener of FIG. 2.

FIG. 2C is a top view of the double helical fastener of FIG. 2.

15 FIG. 3 is a perspective view of yet another embodiment of the present invention, illustrating another design of a double helical fastener.

FIG. 3A is a front view of the double helical fastener of FIG. 3.

FIG. 3B is a side view of the double helical fastener of FIG. 3.

20 FIG. 3C is a top view of the double helical fastener of FIG. 3.

FIG. 4 is a perspective view of the present invention, illustrating a helical fastener with a central post.

25 FIG. 5 depicts a schematic cross-sectional view of an applicator of the present invention, illustrating a side view of the applicator.

-10-

FIG. 6 is a schematic cross-sectional side view of a terminal end of the applicator.

FIG. 6A is a schematic cross-sectional end view of a terminal end of the applicator.

5 FIG. 7 is a schematic cross-sectional view of the terminal end of the applicator, illustrating the preferred embodiment of the terminal end.

10 FIG. 7A is a schematic cross-sectional end view of the preferred embodiment of the terminal end of the application shown in FIG. 7.

FIG. 8 is a schematic cross-sectional view of the terminal end of the applicator, illustrating another embodiment of the terminal end.

15 FIG. 8A is a schematic cross-sectional end view of the embodiment of the terminal end of the applicator shown in FIG. 8.

FIG. 9 is a schematic cross-sectional view of the terminal end of the applicator, illustrating yet another embodiment of the terminal end.

20 FIG. 9A is a schematic cross-sectional end view of the embodiment of the terminal end of the applicator shown in FIG. 9.

25 FIG. 10 is a schematic cross-sectional view of the terminal end of the applicator, illustrating still yet another embodiment of the terminal end.

FIG. 10A is a schematic cross-sectional end view of the embodiment of the terminal end of the applicator shown in FIG. 10.

-11-

FIG. 11 is a schematic cross-sectional view of the terminal end of the applicator, illustrating another embodiment of the terminal end.

5 FIG. 11A is a schematic cross-sectional end view of the embodiment of the terminal end of the applicator shown in FIG. 11.

FIG. 12 is a schematic cross-sectional view of the terminal end of the applicator, illustrating a further embodiment of the terminal end.

10 FIG. 12A is a schematic cross-sectional end view of the embodiment of the terminal end of the applicator shown in FIG. 12.

FIG. 13 is a schematic cross-sectional view of the terminal end of the applicator, illustrating a still further embodiment of the terminal end.

FIG. 14 is a schematic cross-sectional view of the terminal end of the applicator, illustrating still yet another embodiment of the terminal end.

20 FIG. 15. is a schematic cross-sectional view of another applicator of the present invention, illustrating a side view of the applicator.

FIG. 16 is a schematic partial cross-sectional view of a releasable connection between the lead screw and rotator.

25 FIG. 16A is schematic representation of a distal end of the lead screw, illustrating an end view of the lead screw.

-12-

FIG. 16B is a schematic representation of the distal end of the lead screw, illustrating a side view of the lead screw depicted in FIG. 16.

5 FIG. 16C is a schematic representation of the proximal end of the rotator, illustrating a side view of the rotator.

FIG. 16D is a schematic representation of the proximal end of the rotator, illustrating an end view of the rotator depicted in FIG. 16B.

DETAILED DESCRIPTION OF THE PREFERRED EMBODIMENTS

As is shown in the drawings, which are included for purposes of illustration and not by way of limitation, the invention is embodied in a continuous helical fastener and an applicator therefor. The helical fastener has a high retentive surface area and the applicator has a simple design and functions to dispense the helical fasteners, without substantially deforming the fasteners, into body tissue, access to which is from one direction only. Some conventional fasteners require deformation to hold tissue and are consequently limited since they require complex applicators to attach them into tissue. Other conventional fasteners lack high retentive surface area for securely holding tissue. Still other fastener/applicator systems require access to tissue from two directions in order to accomplish attaching a fastener to tissue. Thus, the helical fastener and applicator of the present invention provides a superior means to attach fasteners to tissue.

One embodiment of the present invention (FIGS. 1, 1A and 5) is embodied in a helical fastener 10 which is attached to tissue by employing a novel applicator 12 which rotates the fastener 10 into tissue. The dimensions and physical characteristics of the helical fastener 10 are selected to insure a secure attachment of the fastener 10 to tissue. Similarly,

-14-

the dimensions and physical characteristics of the applicator 12 utilized to dispense the fasteners 10 into tissue are dependent upon the application.

In a preferred embodiment, the fastener 10 is formed into the configuration of a continuous helix and may have a depth 16, a diameter 18 and a pitch 20 determined by the application. The continuous helix may be longitudinally collapsible and expandable. The cross-sectional profile of the continuous helix is substantially circular in the preferred embodiment but can be square, rectangular or triangular. In a particular application such as mesh anchoring for hernia repair, the pre-formed pitch can be .050 inches. However, the pre-formed pitch can vary from 0 to a maximum of approximately 3.0 times the coil diameter. In other embodiments, it is contemplated that the pitch 20 vary along the length of the fastener 10 so as to optimize the retaining force of the fastener 10. Moreover, since the continuous helical coil is preferably longitudinally collapsible and expandable, upon insertion into tissue, the final pitch 31 may be less than or greater than the pre-formed pitch. If the coil is made of rigid construction, as is also contemplated, pitch would be made substantially fixed. The diameter in the preferred embodiment may be 5 mm; however, designs ranging from 1 mm and up are contemplated. In practice, the depth 16 of the fastener 10 must be selected so that the extent of

-15-

fastener penetration into tissue is sufficient to hold the fastener 10 in place.

Moreover, distal end 22 of the fastener 10 is to be configured such that a gap 23 exists between the most distal coil 27 (or first coil) of the fastener 10 and its adjacent coil. As may be appreciated from the preferred embodiment of FIGS. 1B through 1E, as the fastener 10 is pressed against tissue 25, all of the coils substantially collapse except the most distal coil 27, leaving the gap 23 to determine the path the fastener 10 takes as it is rotated into the tissue 25 and more importantly, the extent of penetration 29 into the tissue 25 and final pitch 31 of the fastener 10 in tissue. Although FIG. 1B shows substantially all of the coils being collapsed, it is to be appreciated that, depending upon the applicator utilized to implant the fastener 10, fewer coils than all of the coils may be collapsed at any one time. It remains, however, that since the fastener 10 is longitudinally collapsible and expandable, it is the gap 23 that generally determines final pitch 31. Accordingly, the magnitude of the gap 23 can be varied, depending upon the application, to achieve the desired final pitch 31 and penetration 29 in tissue. Thus, the greater the gap 23, upon insertion of the fastener 10 in tissue, the greater the penetration 29 and final pitch 31 of the fastener 10 in tissue.

-16-

In the preferred embodiment, the distal end 22 of the helical fastener 10 terminates with a point 24. The point 24 may be sharp or blunt depending upon the tissue to which the fastener 10 will be affixed.

5 Additionally, one or more barbs or a sharp point projecting in reverse direction to point 24 (not shown) can be added to fastener 10 near point 24 to enhance anchoring characteristics of the fastener. A proximal end 26 of the helical fastener 10 may comprise

10 structure functioning to receive and transmit applied longitudinal forces. In the preferred embodiment, the most proximal coil is formed into a T-bar 33 that perpendicularly sections the diameter 18 of the fastener 10. In alternate embodiments, it is also

15 contemplated that the most proximal coil section the diameter 18 non-perpendicularly or be formed into a spiral 35 existing in a single plane (See FIG. 1F).

Concerning the material of the helical fastener 10, it is contemplated in the preferred

20 embodiment that the fastener be made from semi-stiff implantable wire, such as titanium, wound into a helical shape. In alternate embodiments, the helical fastener 10 may comprise plastic or absorbable materials. Examples of materials that can be used in

25 constructing the helical fastener 10 include titanium, titanium alloys, stainless steel, nickel, chrome alloys and any other biocompatible implantable metals. Other options for materials are liquid crystal polymers,

-17-

HDPE, polyglycolic acid, and polyglycolid hydroxgacetic acid. Further, it may also be desirable to coat the fastener, or a portion thereof, with a biocompatible lubricious material that provides for easier delivery
5 of the fastener into tissue.

In another embodiment of the surgical fastener, the fastener 110 is formed into the configuration of a double helix (See FIGS. 2-2C). By embodying a double helix, the fastener 110 has
10 increased retentive strength as well as means to balance the fastener 110 as it is pressed into tissue. As with the helical fastener 10, the configuration of the double helical fastener 110, i.e., the pre-formed pitch and diameter, may be varied for a particular
15 application and a barb may be employed to enhance anchoring in tissue. Moreover, the materials contemplated are the same as those for the helical fasteners. Further, the double helical fastener 110 is also longitudinally collapsible and expandable and its
20 final pitch is dependent upon the gap 112 existing between the most distal coils 114, 115 of the fastener 110 and their adjacent coils.

Regarding the proximal 118 and distal 120 ends of the double helical fastener 110, they comprise
25 structure to drive the fastener into tissue as well as tissue piercing structures. The proximal end 118 has a connector bar 122 sectioning the diameter of the fastener that connects one helical coil to another and

-18-

functions to receive and transmit longitudinal forces. The distal end 120 terminates with two points 124, 125 for piercing and facilitating the implantation of the fastener 110 into tissue.

5 As may be appreciated by comparing FIGS. 2-2D with FIGS. 3-3D, it is contemplated that the double helical fastener 110 have a full turn design (FIGS. 2-2D) as well as a half turn design (FIGS. 3-3D). It is to be understood, however, that the designs having more
10 than one turn and having other increments of turns are contemplated. It is the applicator that will determine the required number of turns for a specific fastener
110.

In yet another embodiment of the surgical
15 fastener, as shown in FIG. 4, the double helical fastener 110 is provided with a pivot post 130 having a pointed terminal end 132. The pivot post 130 of this embodiment operates to provide the fastener 110 with a stabilizing element so that, as the fastener 110 is
20 being turned, the helical coils cooperatively enter the tissue.

The applicator 12 (FIG. 5) comprises a proximal portion 28 having a handle 30 and an actuator 32 and a cooperating elongated distal portion or
25 cannula 34 housing a plurality of fasteners. In general, through the manipulation of the actuator 32, the fasteners are ejected, one by one, out of a distal portion 34 and into body tissue. The applicator 12,

-19-

hereinafter described in more detail, is equally proficient in driving each of the embodiments of fasteners set forth above into tissue.

In more detail (see FIGS. 6 and 6A), the distal portion 34 comprises an outer tube 36 housing a rotator 38, a lock/clip indicator 40 and a load spring 42. Extending longitudinally along the rotator 38 is a groove 44 which operates to receive the most proximal coil sectioning the fastener. Although FIG. 6 shows only a single fastener (having a single helical design) retained by the rotator 38, it is to be appreciated that the rotator 38 may receive a plurality of fasteners (having a single or double helical design), wherein each fastener has its last coil positioned within the rotator groove 44. Moreover, although not depicted in FIG. 3, it is also contemplated that rather than embodying a groove, the rotator 38 has a cross-sectional profile approximately a "D", wherein the flat portion operates to engage the coil sectioning the fasteners. Irrespective of the configuration of the rotator, however, the rotator is to embody structure functioning to engage a plurality of fasteners and to facilitate turning them into tissue.

It is also to be appreciated that load spring 42 applies a force through the lock clip indicator 40 to bias the plurality of fasteners distally. The lock clip/indicator 40 may comprise a simple washer sized and shaped to engage the fasteners and rotator 38 as

-20-

well as to receive forces from the load spring 42. Additionally, lock/clip indicator 40 serves as a jam stop to prevent further actuation by rotator 38 upon discharge of all fasteners by mating with, or abutting against, structure comprising the terminal end 50 and preventing further rotation. Lock/indicator 40 can be made of a color (or shape) to serve as an empty indicator notifying the user that no more fasteners are available. Other embodiments of the indicator 40 may be utilized as long as they function to transmit forces to bias the fasteners distally. The load spring 42 is to be retained within the outer tube 36 and to have physical characteristics such that sufficient forces may be applied through a front end 43 to a last remaining fastener contained within the applicator 12. A back end (not shown) of the load spring 42 may be placed against any stationery structure within the outer tube 36, thereby providing a foundation against which the spring 42 may be compressed. In a preferred embodiment, the load spring 42 extends substantially the length of the distal portion 34.

In the preferred embodiment (FIGS. 7 and 7A), the outer tube 36 is configured with a thread form 201 comprising an interlock spring 203 fixedly retained within the outer tube 36 and extending substantially the length thereof. The interlock spring 203 may be fixedly retained within the outer tube 36 by ensuring a tight interference between the parts or the interlock

-21-

spring may be spot welded or equivalently bonded within the outer tube. The thread form 201 operates to guide the fasteners through the distal portion 34 and to eject them from the applicator 12.

5 In another embodiment of the applicator 12 (FIGS. 8 and 8A), attached at a terminal end 46 of the distal portion 34 may be a nose piece 48. The nose piece 48 may further comprise a protrusion 50 extending perpendicularly and towards a longitudinal axis 52 of
10 the distal portion 34. This nose piece protrusion 50 also functions to engage the surgical fasteners and to force them from the terminal end 46 of the distal portion 34 as well as engaging lock/clip indicator 40 as described above.

15 In other embodiments of the applicator 12, the distal portion embodies other structure or thread forms functioning to engage the surgical fasteners and guide them out of the applicator and into tissue (See FIGS. 9-14). In FIGS. 9 and 9A, the outer tube 36 is
20 rolled at its terminal end 46 and a 180° portion of the rolled terminal end is cut away. The remaining rolled portion engages the fastener while the portion cut away provides an exit for the fasteners. The embodiment depicted in FIGS. 10 and 10A is similar to that of
25 FIGS. 9 and 9A, the difference being that instead of removing a portion of the rolled terminal end 46, it is stamped or deformed to thereby provide an exit. FIGS. 11 and 11A show yet another embodiment, wherein two

-22-

longitudinally spaced apart stabilizing points 301, 302 are formed 180° from each other within the outer tube. These stabilizing points also operate to engage the fastener and guide it into tissue. Turning to FIGS. 5 12, 12A, 13 and 14, they each comprise a terminal end 46 formed with threads which operate to engage and eject a fastener. In FIGS. 12 and 12A are depicted threads machined or formed solely within the inside of the outer tube. FIG. 13 shows an internally threaded sleeve attached to the outside of the terminal end 46 10 of the outer tube 36. FIG. 14 illustrates an applicator 12 provided with a terminal end 46 deformed so as to have internal and external threaded structures. Irrespective of the design chosen for the terminal end of the applicator, however, each of the 15 designs are effective with a relatively small overall outer diameter, i.e., on the order of 5mm.

In order to eject surgical fasteners from the distal portion 34, the actuator 32 functions to turn 20 the rotator 38. As the rotator turns, the distal end 22 of a fastener is threaded out of the terminal end 46 of the applicator 12 (see FIG. 5).

In the preferred embodiment of the proximal portion 28 of the applicator 12 (See FIG.5), a lever 54 25 is pivotally connected about a midpoint 56 to the handle 30. A first end 58 of the lever 54 is to be configured for gripping by hand. A second end 60 of

-23-

the lever is to be adapted to pivotally engage a nut driver 62.

The nut driver 62 of the applicator 12 travels upon a high helix lead screw 64 which is rotatably mounted within the proximal portion 28. In the preferred embodiment, a longitudinal axis of the high helix lead screw 64 is coaxial with the longitudinal axis 52 extending through the distal portion 34 of the applicator 12. Upon manipulation of the lever 54, the nut driver 62 travels along the lead screw 64 causing it to rotate through a connection of the lead screw 64 to the rotator 38, the action of the lead screw causes the rotator to rotate. The lead screw 64 may be connected to the rotator 38 by any conventional means. For instance, the lead screw 64 can have an internal bore receiving and engaging an end of the rotator 38. Further, the length of travel of the nut driver 62 along the lead screw 64 is chosen such that it causes the rotator to rotate a predetermined number of times so that a single helical fastener 10 is ejected from the applicator 12.

Additionally, in the preferred embodiment, the lever further comprises a midsection extension 66. Pivotaly attached to the midsection extension 66 of the lever 54 is contemplated to be a spring loaded pawl 68 adapted to releasably engage gear teeth 70 formed in the interior of the handle 30. Spring loaded pawl 68 is configured to prohibit the lever 54 from

-24-

backstroking until it has been completely depressed. Upon complete depression of the lever 54, the pawl 68 clears the gear teeth 70 and the spring biasing the pawl 68 rotates the pawl 68 away from the teeth 70, thereby allowing the lever 54 to return to its undepressed condition.

In operation, upon complete depression of the lever 54, the nut driver 62 travels a pre-determined distance along the lead screw 64, causing the rotator 38 to rotate a pre-determined number of revolutions corresponding to a number of turns of a particular helical fastener 10. As the rotator 38 rotates, the fasteners retained by the rotator also rotate and the coils of the most distal fastener are threaded out of the terminal end 46 of the applicator 12 and into tissue. Moreover, where the lever 54 is only partially depressed, the spring loaded pawl 68 operates to hold the lever 54 stationery and will continue to function to hold the lever 54 stationery until the lever 54 has been completely depressed. In this way, the delivery of fasteners into body tissue is controlled so that only a single fastener may be completely ejected out of the applicator 12 and pressed into body tissue at a time.

In the preferred embodiment, the proximal portion 28 is fabricated to have a reusable handle that can be re-sterilized, and the distal portion is made disposable. Thus, upon discharge of all the fasteners

-25-

10 from distal portion 34, the distal portion would be discarded and replaced. The handle could be reused up to a limited number of procedures.

In another embodiment of the proximal portion
5 328, of the applicator 312 (FIG. 15), a lever 354 is pivotally connected at a first end 355 to the handle 330 and biased to its undepressed position by a spring 357. The mid-section 358 of the lower 354 is configured for gripping by hand. A second end 360 of
10 the lever is to be adapted to pivotally engage a nut drive 362.

The nut driver 362 of the applicator 312 travels along a high helix lead screw 364 which is rotatably mounted within the proximal portion 328.
15 Upon manipulation of the lever 354, the nut driver travels along the lead screw 364 causing it to rotate and, through a clutch assembly or a releasable connection of the lead screw 364 to the rotator 38, the action of the lead screw causes the rotator to rotate.

20 Further, the lever 354, has a mid-section extension 366 that cooperates with a spring biased latch pawl mechanism 368 fixed to the handle adapted to releasably engage teeth 370 formed on the mid-section extension 366. The spring biased latch pawl is
25 configured to prohibit the lever 354 from backstroking until it has been completely depressed. Upon complete depression of the lever 354, the latch pawl 368 clears the mid-section teeth 370 and the spring biased latch

-26-

pawl 368 rotates away from the teeth, thereby allowing the lever 354 to return to its undepressed condition.

As stated, there is a releasable connection between the lead screw 364 and the rotator. The
5 releasable connection provides the applicator with means to disengage the distal portion of the applicator from the proximal portion. In this way, the proximal portion can be re-used with various different designs of the proximal portion. Further, while the lever 354
10 is being depressed, the clutch assembly or releasable connection functions to transfer the rotation of the lead screw 364 to the rotator 38, thereby causing the rotator to rotate. Additionally, upon complete depression of the lever, the clutch assembly operates
15 to allow relative motion of the lead screw 364 and the rotator.

One such releasable connection contemplated is a conventional ratchet mechanism. As shown in FIGS. 16-16D, the distal end 370 of the lead screw 364 has a
20 connecting surface 372 equipped with leaf springs 374, 376 each having an engaging face 377 and an internal bore 378 existing coaxially with a longitudinal axis of the lead screw. The proximal end 380 of the rotator 38 has a cooperating connecting surface 382 having ridges
25 384 for releasable engagement with the leaf springs 374, 376 and an extension 386 adapted to fit within the internal bore of the lead screw connecting surface. As may be appreciated from the FIGS., as the lead screw

-27-

turns so that the ridges 384 contact the engaging faces
377 of the leaf springs 374, 376, the rotation of the
lead screw 364 will cause the rotator 38 to likewise
rotate. Where the lead screw is turned in the opposite
5 direction, the ridges 384 will not engage the engaging
face of the leaf springs and the motion of the lead
screw 384 will not be transferred to the rotator 38.

In this embodiment, upon complete depression
of the lever 354, the nut driver 362 travels a pre-
10 determined distance along the lead screw 364, causing
the rotator 38 to rotate a pre-determined number of
revolutions. As the rotator 38 rotates, the fasteners
retained by the rotator also rotate and the coils of
the most distal fasteners are threaded out of the
15 applicator and into the tissue. At this point, the
latch pawl mechanism 368 disengages from the teeth 370
and the lever 354 is returned to its undepressed
position by spring 357. As with the previous
embodiment of the proximal portion 28, the proximal
20 portion of this embodiment functions to allow only a
single fastener to be completely ejected from the
applicator and be pressed into body tissue at a time.

In other embodiments, means to cause the
rotator to rotate may comprise a single knob connected
25 to a rotator which can be turned by hand.
Additionally, the revolving means may include a rack
and gear structure or a set of beveled gears. Further,
instead of comprising a groove, the rotator may be

-28-

internally threaded, wherein the threaded portions function to house as well as advance the helical fasteners 10. Irrespective of the means or structure employed, however, it is contemplated that the number of revolutions of the rotator be set to a pre-determined parameter so that the delivery of helical fasteners to tissue may be controlled.

From the foregoing, it will be appreciated that the helical fastener in applicator of the present invention functions to securely attach a fastener with high retentive surface area to tissue from one direction through the utilization of an applicator having a simple design. It is also to be appreciated that the present invention may be utilized in a number of applications including ligating tissue, hernia mesh repair, bladder neck suspension, and in conjunction with implant drug delivery systems or procedures involving positioning of surgical or implantable devices in patient.

While several particular forms of the invention have been illustrated and described, it will also be apparent that various modifications can be made without departing from the spirit and scope of the invention.

Thus, it should be understood that various changes in form, detail and application of the present invention may be made without departing from the spirit and scope of this invention.

-29-

WHAT IS CLAIMED IS:

1. A fastener for ligating tissue or attaching an implantable device, the fastener comprising:

5 a continuous helical coil having a distal end and a proximal end;

a first helical coil section at said distal end;

tissue piercing means on said first coil; and
10 means for inserting said continuous helical coil so that said continuous helical coil penetrates tissue to ligate the tissue to position and attach the implantable device.

2. The fastener of claim 1, wherein said tissue piercing means is a point formed at a terminal end of said first helical coil section.

3. The fastener of claim 2, wherein said point of said first helical coil section and an adjacent coil section define a gap, said gap adapted to determine depth of penetration and pitch of the
5 fastener in tissue and retentive strength of the fastener to tissue.

-30-

4. The fastener of claim 1, wherein said continuous helical coil has a uniform pitch between coils.

5. The fastener of claim 1, wherein said continuous helical coil has a pitch between coils that can be varied by an applicator.

6. The fastener of claim 1, wherein said continuous helical coil has a pitch sufficient to entrap tissue between coils.

7. The fastener of claim 1, wherein said continuous helical coil has a pitch that can be increased as said fastener is inserted into the tissue.

8. The fastener of claim 1, wherein said continuous helical coil has a pitch of .050 inches.

9. The fastener of claim 1, wherein said continuous helical coil has a pitch range from 0 to a maximum of 3.0 times a diameter of said helical coil.

10. The fastener of claim 1, wherein said means for inserting said continuous helical coil is a T-bar at said proximal end.

-31-

11. The fastener of claim 10, wherein a rotational force and a longitudinal force is applied to said T-bar by an applicator that rotates and delivers said continuous helical coil into tissue.

12. The fastener of claim 1, wherein said continuous helical coil is sized to fit within a cannula having a diameter of at least 1mm.

13. The fastener of claim 1, wherein at least a portion of said continuous helical coil is coated with a biocompatible lubricious material for facilitating delivery of the fastener into tissue.

14. The fastener of claim 1, wherein said continuous helical coil is made from absorbable material.

15. The fastener of claim 1, wherein said continuous helical coil is made from a metallic material selected from the group of materials consisting essentially of titanium, titanium alloys, stainless steel and nickel chrome alloys.

16. The fastener of claim 1, wherein said continuous helical coil is made from a polymeric material selected from the group of materials consisting essentially of plastics, liquid crystal

-32-

10 polymers, HDPE, polyglycolic acid, and polyglycolid hydroxgacetic acid.

17. The fastener of claim 1, wherein said continuous helical coil is longitudinally collapsible and expandable.

18. The fastener of claim 1, further comprising one or more barbs projecting in reverse direction and positioned proximate to said tissue piercing means.

19. A fastener for ligating tissue or for attaching an implantable device, the fastener comprising:

a continuous helical coil having a distal end and a proximal end;

5 a point on said distal end for piercing the tissue;

a first helical coil section adjacent said distal end and having a gap between said point and said first helical coil section; and

10 a T-bar section at said proximal end for engagement with an applicator for inserting said helical coil through the tissue to position and attach the implantable device.

-33-

20. The fastener of claim 19, wherein said gap is adapted to determine depth of penetration and pitch of the fastener in tissue and retentive strength of the fastener to tissue.

21. The fastener of claim 19, wherein said continuous helical coil has a uniform pitch between coils.

22. The fastener of claim 19, wherein said continuous helical coil has a pitch between coils that can be varied by the applicator.

23. The fastener of claim 19, wherein said continuous helical coil has a pitch that can be increased as the fastener is inserted into the tissue.

24. The fastener of claim 19, wherein said continuous helical coil is made from absorbable material.

25. The fastener of claim 19, wherein said continuous helical coil is made from a metallic material selected from the group of materials consisting essentially of titanium, titanium alloys, stainless steel and nickel chrome alloys.

-34-

26. The fastener of claim 19, wherein said continuous helical coil is made from a polymeric material selected from the group of materials consisting essentially of plastics, liquid crystal polymers, HDPE, polyglycolic acid and polyglycolid hydroxgacetic acid.

27. The fastener of claim 19, wherein said continuous helical coil is longitudinally collapsible and expandable.

28. The fastener of claim 19, further comprising one or more barbs projecting in reverse direction and positioned proximate to said point.

29. A fastener for ligating tissue or for attaching an implantable device, the fastener comprising:

- a continuous double helical coil having a distal end and a proximal end;
- said distal end terminating with dual points each for piercing the tissue;
- dual first helical coil sections adjacent said distal end each being associated with one of said dual points and each defining a gap therebetween; and
- a connecting bar at said proximal end for engagement with an applicator for inserting said double

-35-

helical coil through the tissue to position and attach the implantable device.

30. The fastener of claim 29, wherein said gap is adapted to determine depth of penetration and pitch of the fastener in tissue and retentive strength of the fastener to tissue.

31. The fastener of claim 29, wherein said continuous double helical coil has uniform pitch between coils.

32. The fastener of claim 29, wherein said continuous double helical coil has a pitch between coils that can be varied by the applicator.

33. The fastener of claim 29 wherein said continuous double helical has a pitch that can be increased as the fastener is inserted into the tissue.

34. The fastener of claim 29, where said continuous double helical coil is made from absorbable material.

35. The fastener of claim 29, wherein said continuous double helical coil is made from a metallic material selected from the group of materials

-36-

consisting essentially of titanium, titanium alloys,
5 stainless steel and nickel chrome alloys.

36. The fastener of claim 29, wherein said
continuous double helical coil is made from a polymeric
material selected from the group of materials
consisting essentially of plastics, liquid crystal
5 polymers, HDPE, polyglycolic acid and polyglycolid
hydroxgacetic acid.

37. The fastener of claim 29, wherein said
continuous double helical coil is longitudinally
collapsible and expandable.

38. The fastener of claim 29, further
comprising a pivot post extending from said connecting
bar and toward said distal end, said pivot post having
a pointed terminal end.

39. The fastener of claim 29, further
comprising one or more barbs projecting in reverse
direction and positioned proximate to said dual points.

40. An applicator for attaching fasteners to
body tissue comprising:

a distal portion having an elongate outer
tube, a connecting end and a terminal end;

-37-

5 a proximal portion having a handle and an
actuator, said proximal portion attached to said
connecting end of said distal portion;

a rotator contained in said outer tube;
said rotator adapted to receive a plurality
of fasteners and adapted to cooperate with said
10 actuator; and

means for threading and ejecting the
fasteners out of said terminal end.

41. The applicator of claim 40, further
comprising:

a lock/clip indicator adapted to engage said
plurality of fasteners; and

5 a load spring adapted to apply longitudinal
forces against said lock/clip indicator and to bias
said plurality of fasteners toward said terminal end.

42. The applicator of claim 41, wherein said
lock/clip indicator is configured to prevent actuation
of said actuator upon discharge of said plurality of
fasteners from the applicator.

43. The applicator of claim 40, wherein a
groove extends longitudinally along substantially the
length of said rotator, said groove adapted to receive
coils of said plurality of fasteners.

-38-

44. The applicator of claim 40, wherein said rotator has a cross-sectional profile approximating a D-shape and is adapted to receive coils of said plurality of fasteners.

45. The applicator of claim 40, wherein said threading and ejecting means is a thread form contained in an interior of said terminal end adapted to engage said plurality of fasteners.

46. The applicator of claim 45, wherein said thread form is an interlock spring fixedly retained in said interior of said terminal end.

47. The applicator of claim 40, wherein said threading and ejecting means a nose piece attached to said terminal end, said nose piece having structure projecting perpendicularly toward a longitudinal axis
5 of said outer tube and adapted to engage said plurality of fasteners.

48. The applicator of claim 40, wherein said distal portion and said proximal position are releasably secured together.

49. The applicator of claim 48, wherein said distal portion is disposable and said proximal portion is reusable.

-39-

50. The applicator of claim 40, wherein said actuator includes:

a lever having a first end and a second end, said lever pivotally attached about a midpoint to said handle;

5 said first end of said lever adapted to be gripped by hand;

a lead screw rotatably attached to an interior of said handle;

a nut driver, said second end of said lever pivotally attached to said nut driver, said nut driver
10 adapted to travel along said lead screw, thereby turning said lead screw; and

said lead screw attached to said rotator so that as the lever is depressed by hand the nut driver will travel along the lead screw toward said rotator
15 thereby turning said rotator in the process.

51. The applicator of claim 50, wherein said lead screw is a high helix lead screw.

52. The applicator of claim 50, wherein said lever has a midsection extension.

53. The applicator of claim 52, further comprising gear teeth formed within said interior of said handle.

-40-

54. The applicator of claim 53, further comprising a spring loaded pawl pivotally attached to said midsection extension and adapted to engage said gear teeth.

55. The applicator of claim 40, wherein said actuator includes:

a lever having a first end, a midsection, and a second end, said first end pivotally attached to said handle, said midsection adapted to be gripped by hand;

a lead screw rotatably attached to an interior of said handle;

a nut driver, said second end pivotally attached to said nut driver, said nut driver adapted to travel along said lead screw, thereby turning said lead screw; and

means for said lead screw to releasably engage said rotator so that as the lever is depressed by hand, the nut driver will travel along the lead screw toward said rotator thereby turning said rotator in the process and so that when the lever is returned to its undepressed position, the lead screw will rotate in the reverse direction and independently of the rotator which remains stationary.

56. The applicator of claim 55, wherein said lead screw is a high helix lead screw.

-41-

57. The applicator of claim 55, wherein said releasable engagement means is a ratchet mechanism.

58. The applicator of claim 55, wherein said lever has a mid-section extension, formed in said mid-section extension are a plurality of teeth.

59. The application of claim 58, further comprising a latch pawl cooperating with said teeth to prohibit said lever from backstroking until it has been completely depressed.

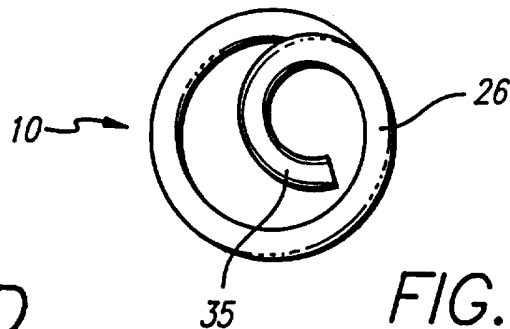
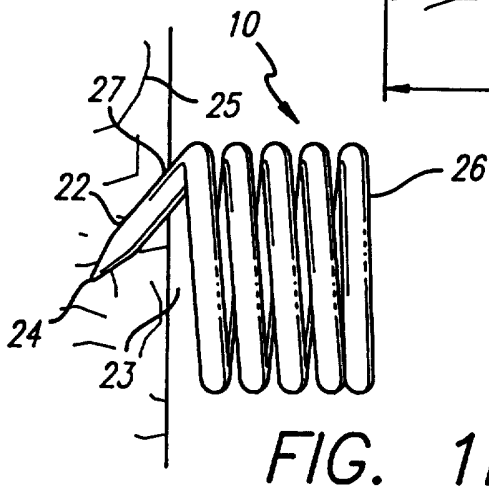
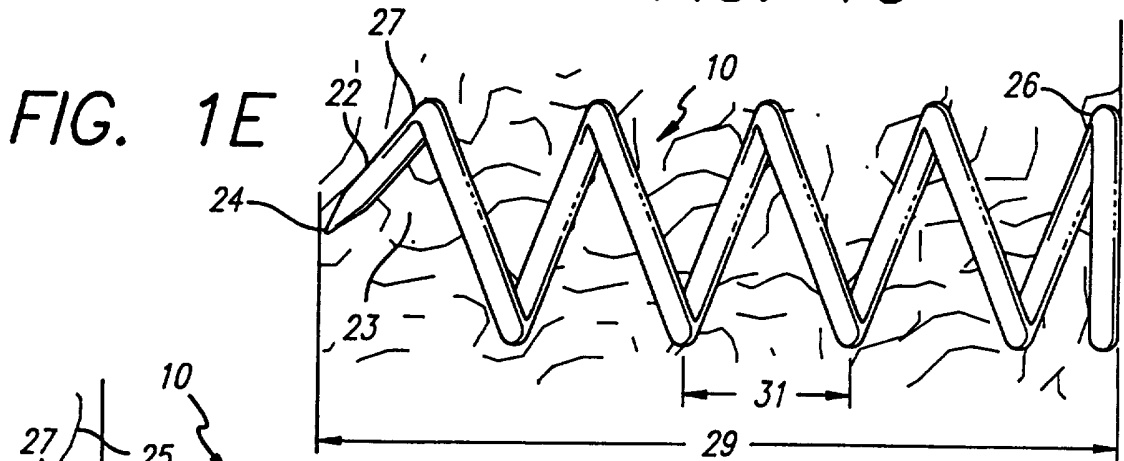
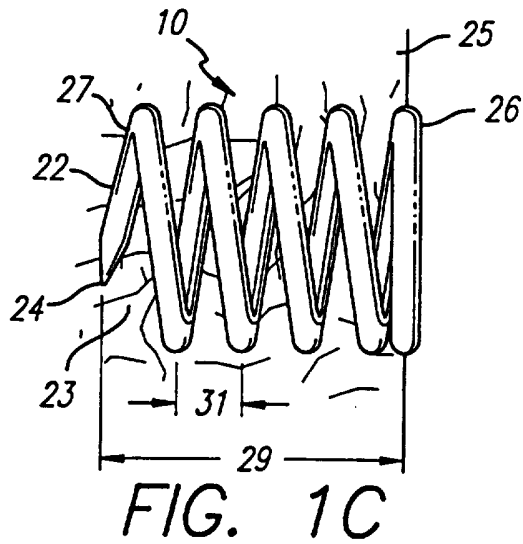
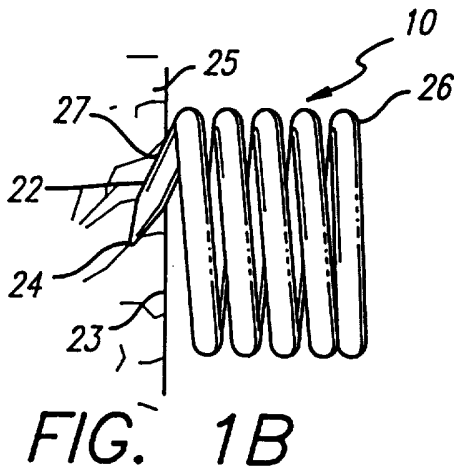
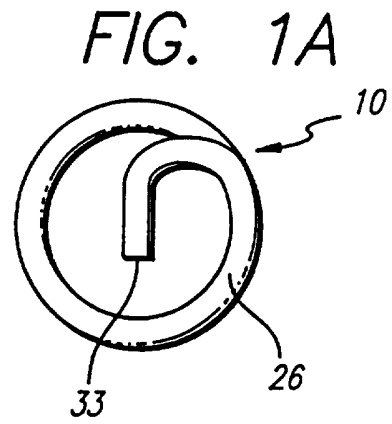
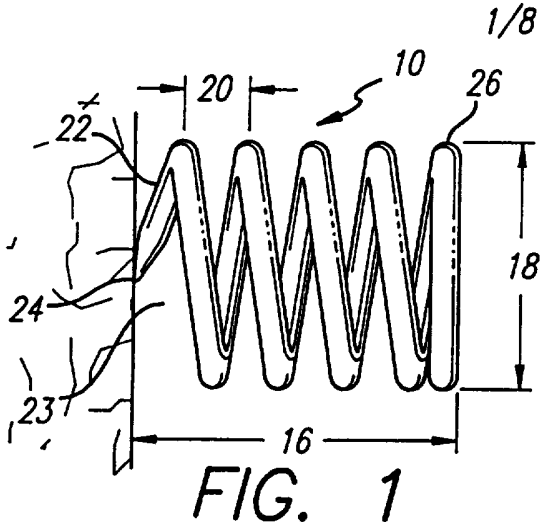

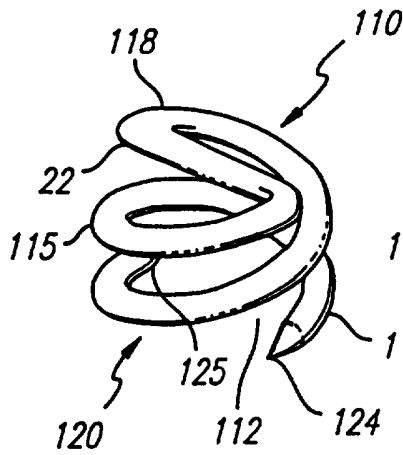

FIG. 2

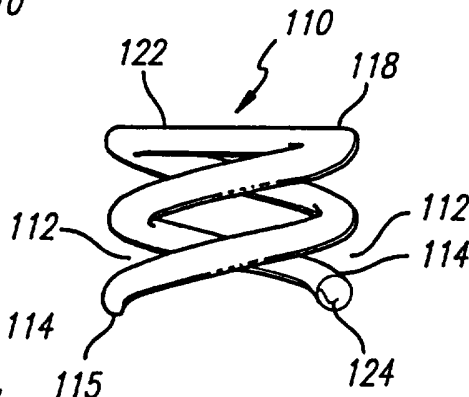

FIG. 2A

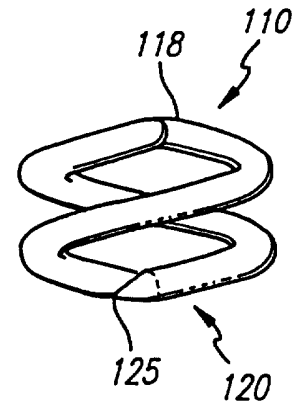

FIG. 2B

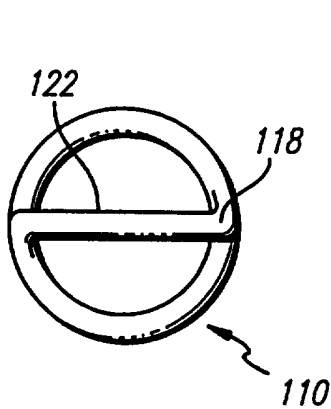

FIG. 2C

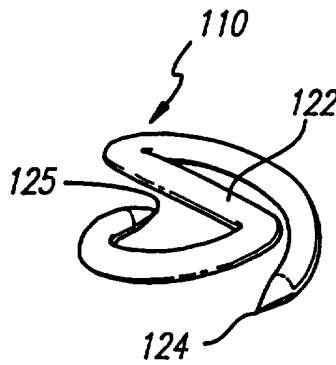

FIG. 3

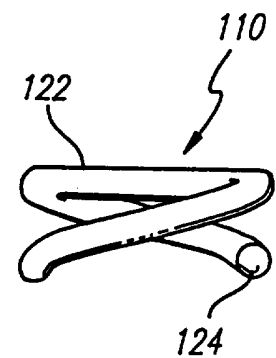

FIG. 3A

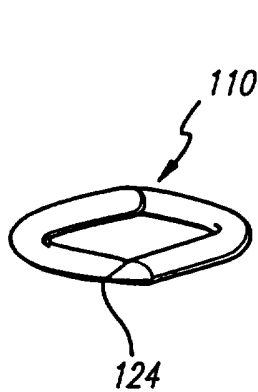

FIG. 3B

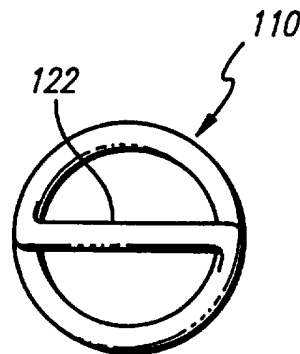

FIG. 3C

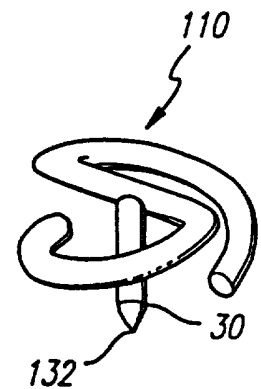

FIG. 4

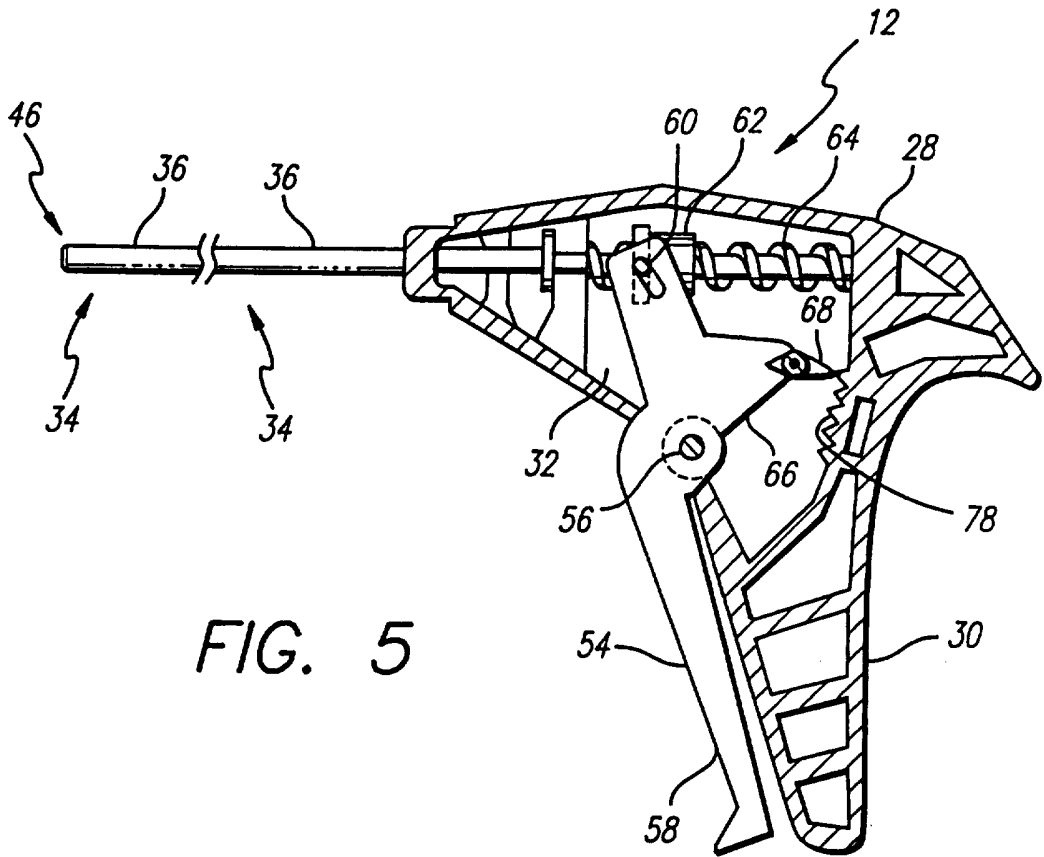

FIG. 5

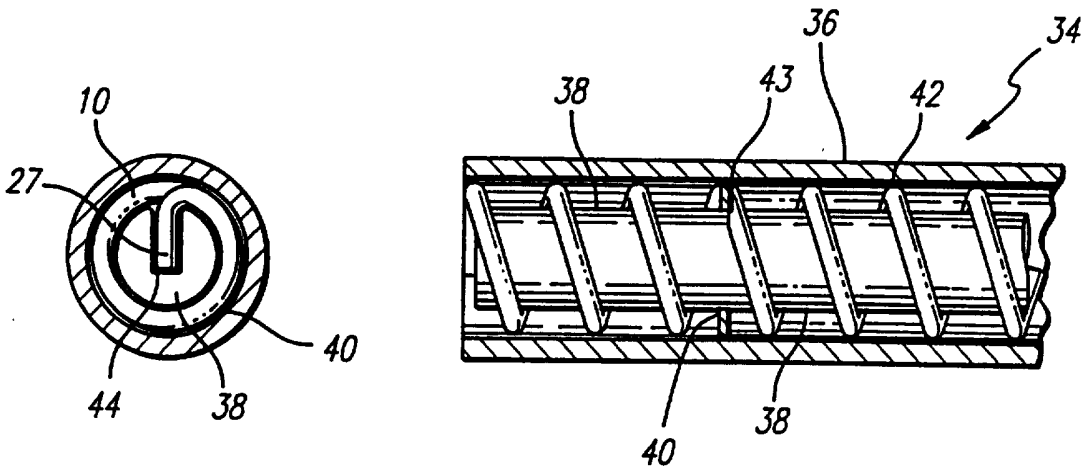

FIG. 6A

FIG. 6

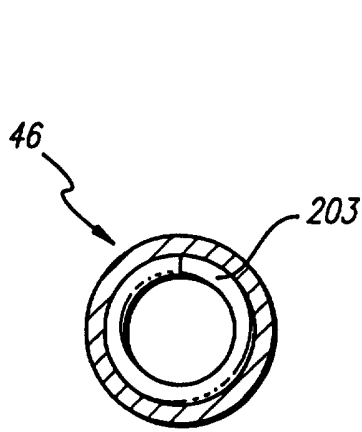

FIG. 7A

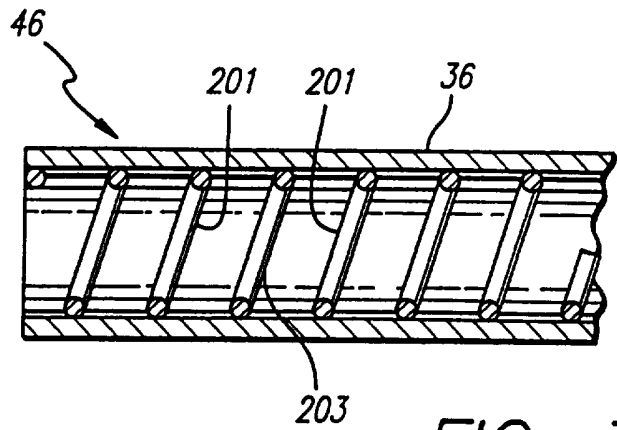

FIG. 7

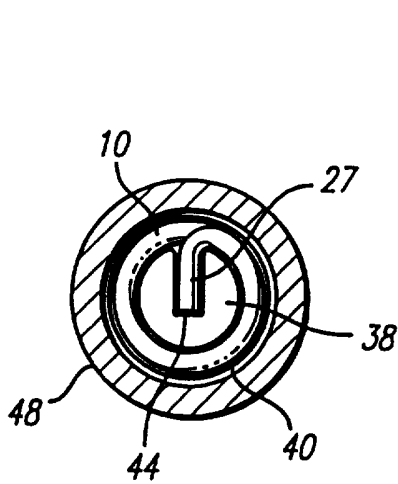

FIG. 8A

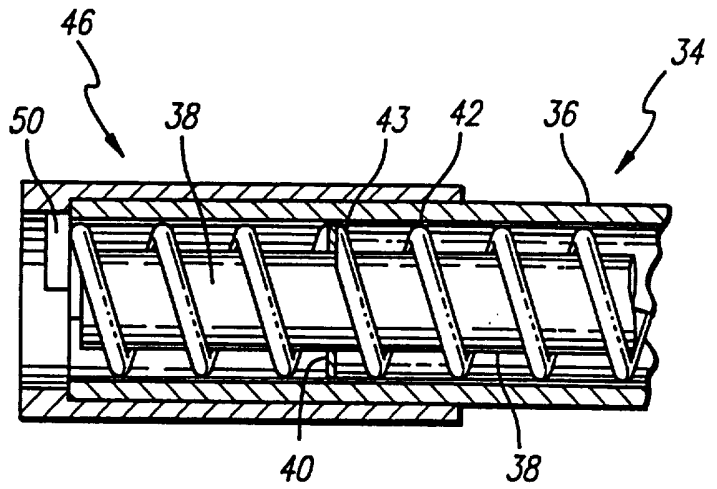

FIG. 8

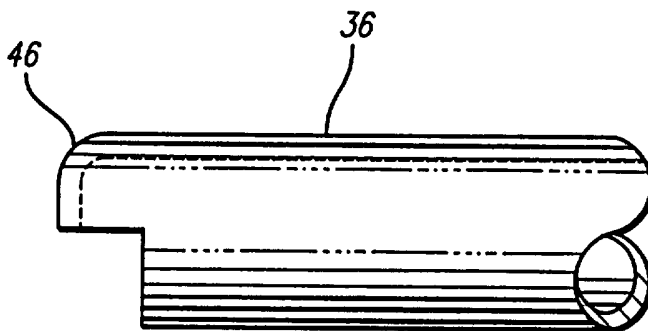

FIG. 9

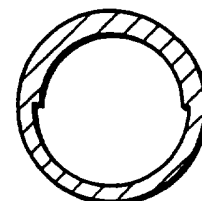

FIG. 9A

FIG. 10

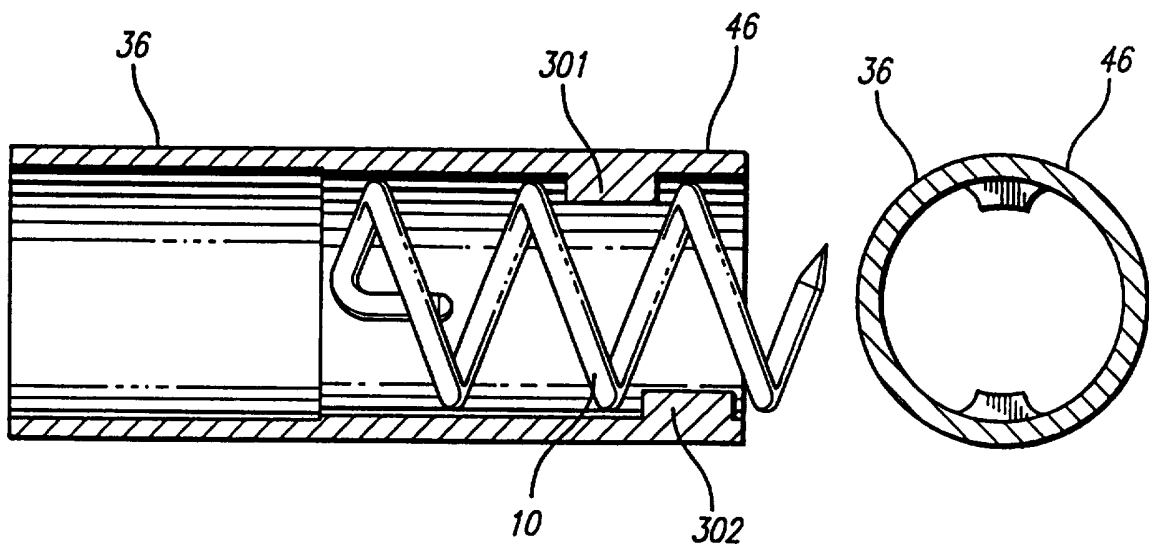
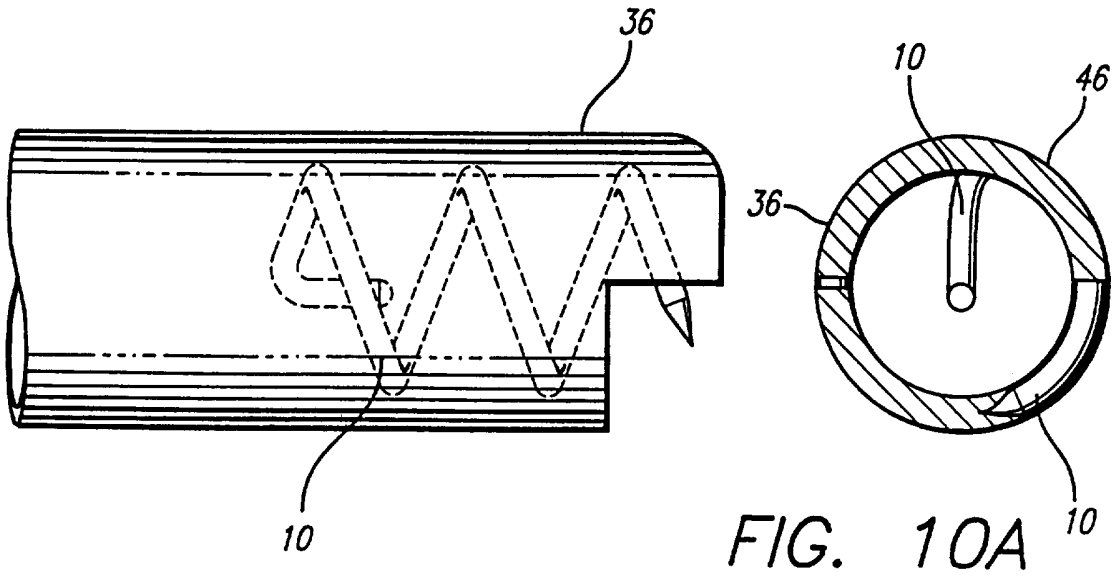

FIG. 11

FIG. 11A

6/8

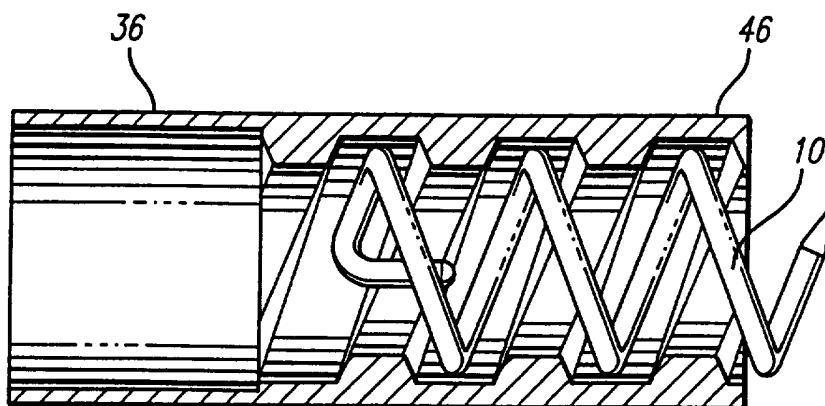

FIG. 12

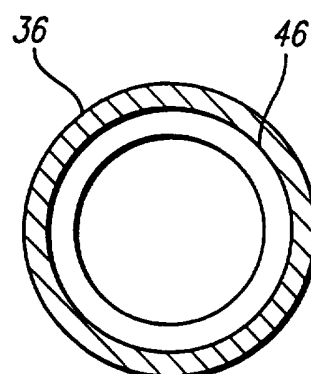

FIG. 12A

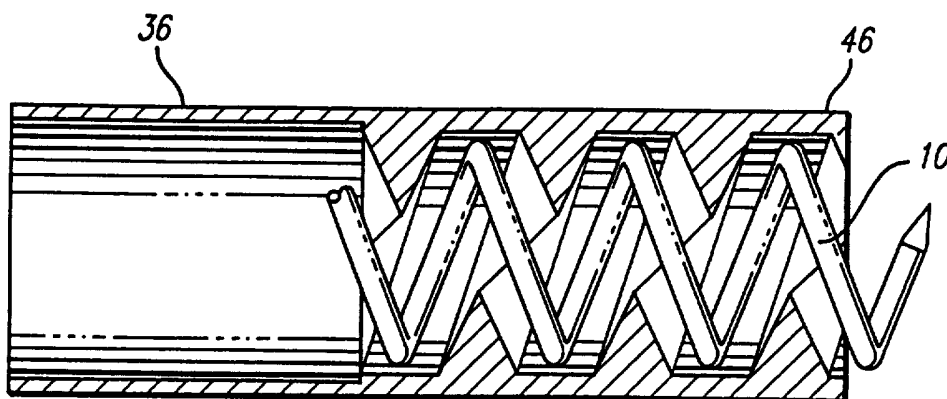

FIG. 13

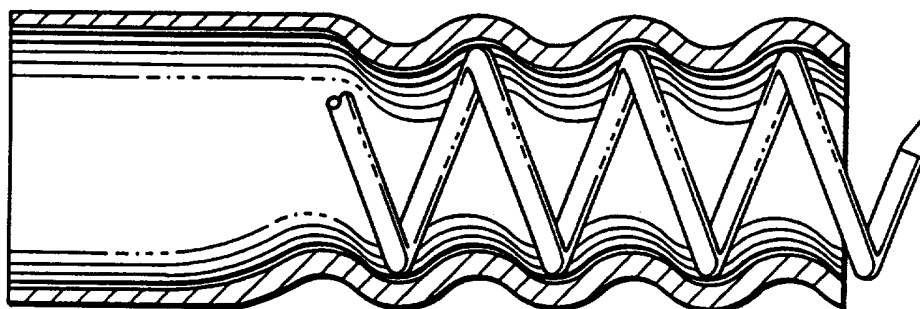
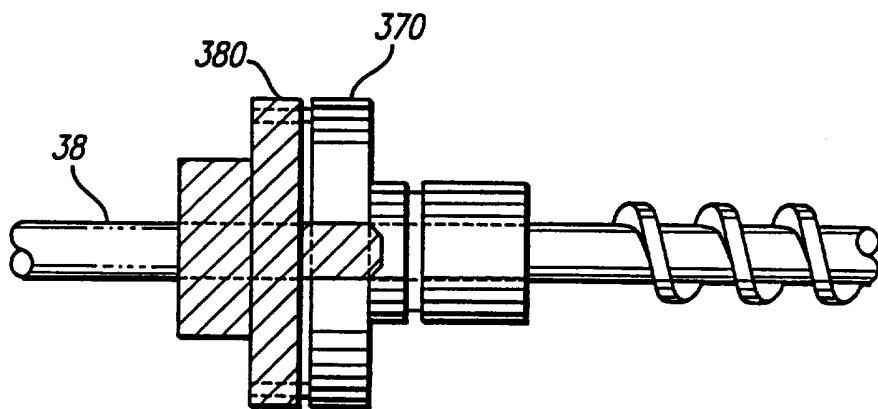
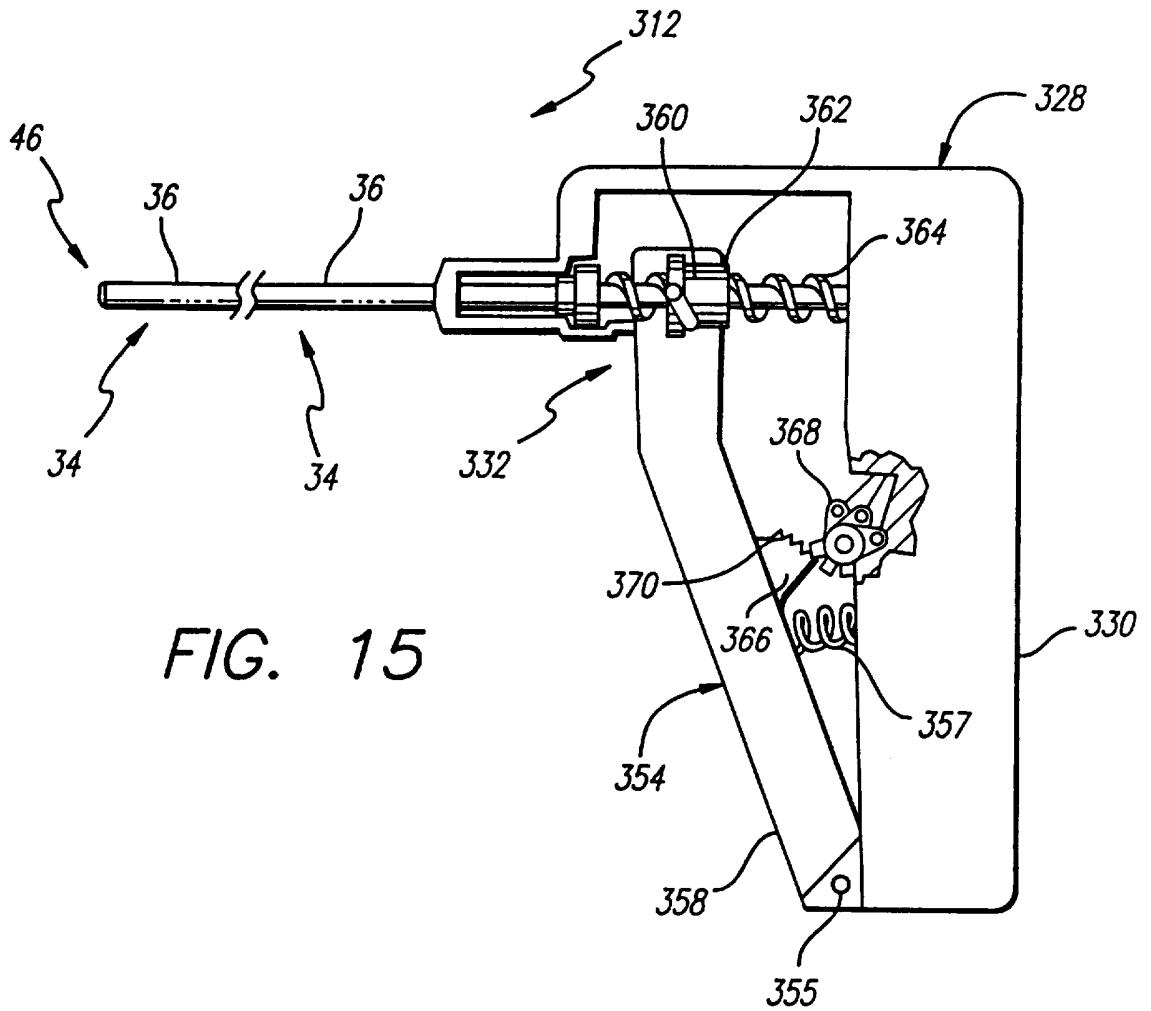

FIG. 14



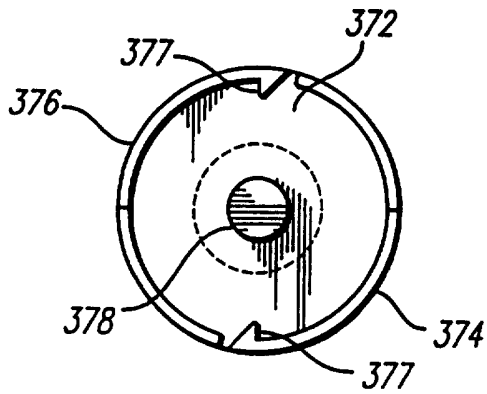

FIG. 16A

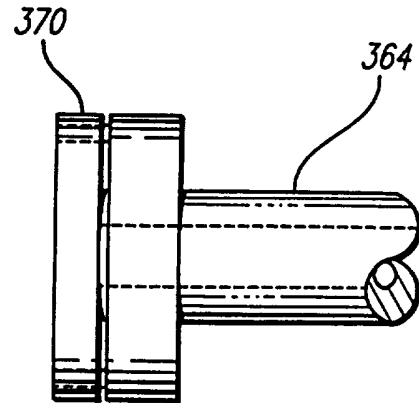

FIG. 16B

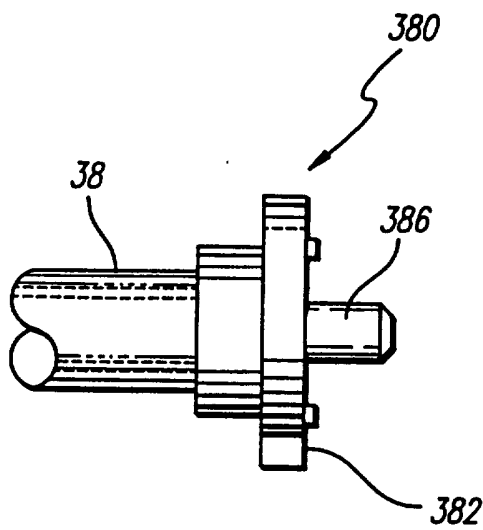

FIG. 16C

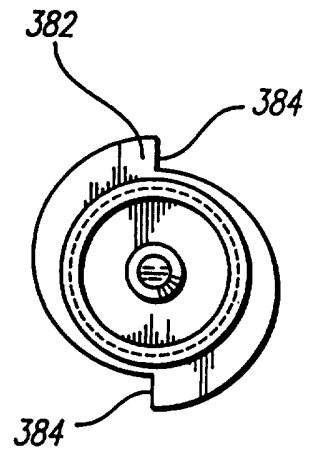

FIG. 16D

INTERNATIONAL SEARCH REPORT

Internat Application No
PCT/US 95/07270

A. CLASSIFICATION OF SUBJECT MATTER
IPC 6 A61B17/06 A61B17/04

According to International Patent Classification (IPC) or to both national classification and IPC

B. FIELDS SEARCHED

Minimum documentation searched (classification system followed by classification symbols)
IPC 6 A61B

Documentation searched other than minimum documentation to the extent that such documents are included in the fields searched

Electronic data base consulted during the international search (name of data base and, where practical, search terms used)

C. DOCUMENTS CONSIDERED TO BE RELEVANT

Category *	Citation of document, with indication, where appropriate, of the relevant passages	Relevant to claim No.
X	EP,A,0 121 362 (ETHICON INC.) 10 October 1984 see page 2, line 29 - page 3, line 28 see page 4, line 26 - page 5, line 11 see page 7, line 8-34; claims 1-8; figures 1-3	1-9, 12, 15, 17
A	---	19, 29
X	WO,A,90 14795 (YOON) 13 December 1990 see abstract; figures 10-14 see page 20, line 3 - page 24, line 18	1-14, 16-28
A	---	29
	-/--	

Further documents are listed in the continuation of box C.

Patent family members are listed in annex.

* Special categories of cited documents :

- *A* document defining the general state of the art which is not considered to be of particular relevance
- *E* earlier document but published on or after the international filing date
- *L* document which may throw doubts on priority claim(s) or which is cited to establish the publication date of another citation or other special reason (as specified)
- *O* document referring to an oral disclosure, use, exhibition or other means
- *P* document published prior to the international filing date but later than the priority date claimed

- *T* later document published after the international filing date or priority date and not in conflict with the application but cited to understand the principle or theory underlying the invention
- *X* document of particular relevance; the claimed invention cannot be considered novel or cannot be considered to involve an inventive step when the document is taken alone
- *Y* document of particular relevance; the claimed invention cannot be considered to involve an inventive step when the document is combined with one or more other such documents, such combination being obvious to a person skilled in the art.
- *&* document member of the same patent family

Date of the actual completion of the international search

24 November 1995

Date of mailing of the international search report

04. 12. 95

Name and mailing address of the ISA

European Patent Office, P.B. 5818 Patentlaan 2
NL - 2280 HV Rijswijk
Tel. (+ 31-70) 340-2040, Tx. 31 651 epo nl,
Fax (+ 31-70) 340-3016

Authorized officer

Giménez Burgos, R

INTERNATIONAL SEARCH REPORT

Internat. Application No.

PCT/US 95/07270

C.(Continuation) DOCUMENTS CONSIDERED TO BE RELEVANT		
Category *	Citation of document, with indication, where appropriate, of the relevant passages	Relevant to claim No.
X	FR,A,2 377 796 (V. N.-I. I. I. M. T.) 18 August 1978 see the whole document	1-9, 12-14, 16,17 19,40
A	---	
X	DE,C,295 962 (KUHLEMANN) 6 May 1916 see page 1, right column, line 51-54; claim; figures	1-4,6, 8-11,15, 19-21,25
A	---	
A	US,A,3 858 783 (KAPITANOV ET AL.) 7 January 1975	40
A	---	
A	FR,A,320 731 (BROWN) 18 December 1902 see figures 1-6	29
A	---	
A	US,A,5 007 921 (BROWN) 16 April 1991 see figures	29

INTERNATIONAL SEARCH REPORT

Information on patent family members

Internati	Application No
PCT/US 95/07270	

Patent document cited in search report	Publication date	Patent family member(s)	Publication date
EP-A-0121362	10-10-84	US-A- 4595007	17-06-86
		AR-A- 231911	30-04-85
		AU-B- 567724	03-12-87
		AU-B- 2557484	20-09-84
		CA-A- 1247488	27-12-88
		JP-A- 59168846	22-09-84
WO-A-9014795	13-12-90	US-A- 5053047	01-10-91
		US-A- 5222976	29-06-93
		US-A- 5330503	19-07-94
FR-A-2377796	18-08-78	CA-A- 1131090	07-09-82
		CH-A- 624291	31-07-81
		DE-A- 2801096	27-07-78
		GB-A- 1560465	06-02-80
		JP-C- 1066413	30-09-81
		JP-A- 53115595	09-10-78
		JP-B- 56006774	13-02-81
		US-A- 4204541	27-05-80
DE-C-295962		NONE	
US-A-3858783	07-01-75	NONE	
FR-A-320731		NONE	
US-A-5007921	16-04-91	US-A- 5026390	25-06-91