

(No Model.)

J. H. FRANKLIN.
CONVEYER.

No. 516,702.

Patented Mar. 20, 1894.

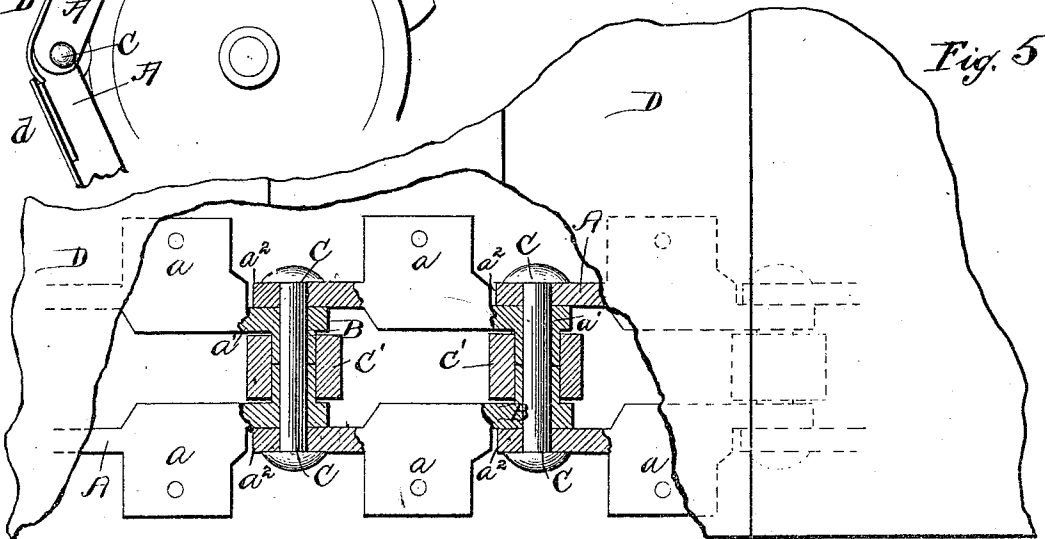
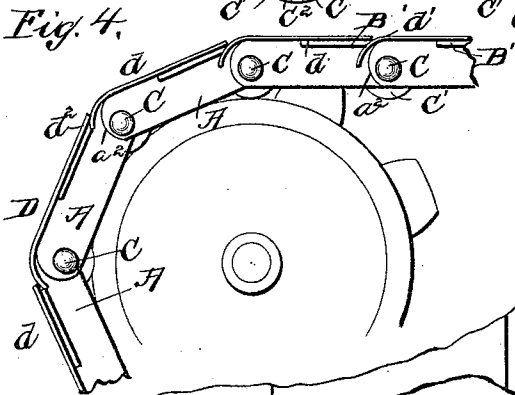
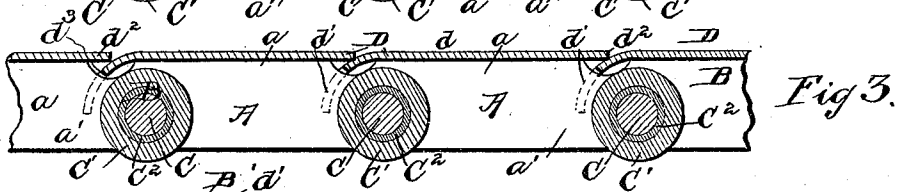
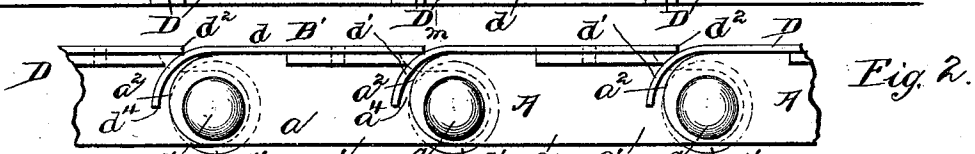
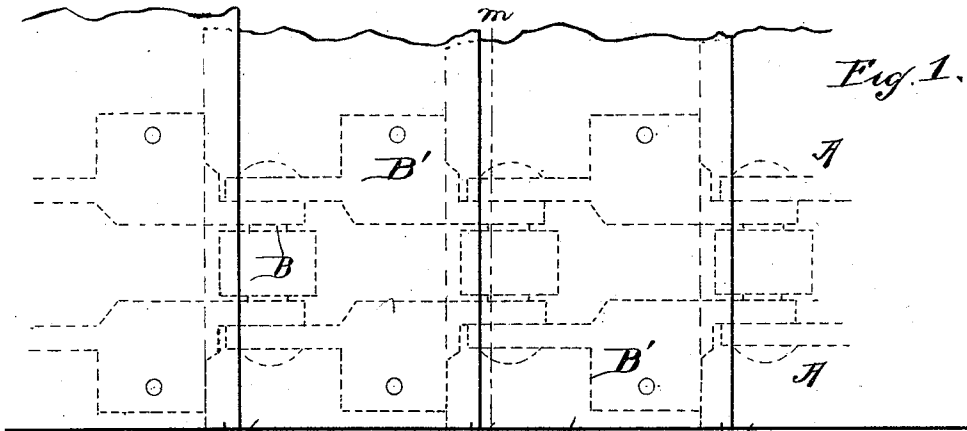

WITNESSES—
Chas. H. K. R. P. L. O. T. E.
Wm. E. Stiff

INVENTOR
John H. Franklin, by
Doubleday & Pines attys.

UNITED STATES PATENT OFFICE.

JOHN H. FRANKLIN, OF COLUMBUS, OHIO, ASSIGNOR TO JOSEPH A. JEFFREY,
OF SAME PLACE.

CONVEYER.

SPECIFICATION forming part of Letters Patent No. 516,702, dated March 20, 1894.

Application filed January 7, 1891. Serial No. 376,978. (No model.)

To all whom it may concern:

Be it known that I, JOHN H. FRANKLIN, a citizen of the United States, residing at Columbus, in the county of Franklin and State of Ohio, have invented certain new and useful Improvements in Conveyers, of which the following is a specification, reference being had therein to the accompanying drawings.

This invention relates to improvements in devices for elevating or conveying materials from one place to another, it providing improvements especially adapted for use in conveyers for materials which are more or less in a state of subdivision or in masses composed in part or entirely of small particles. Conveyers of this sort are largely used for transporting sand, coal, clay, &c., and these and other similar materials are apt to rapidly destroy the chains, first, because they bring a great weight to bear upon the links, and secondly, because the gritty particles are liable to find access to the articulating parts of the chain links. The mechanism which I have devised obviates the difficulties which I have found incident to conveyers used in the transporting of sand, clay and other materials, as the chain is of such construction as to permit numerous anti-friction rollers to be readily applied at points directly beneath the load, and the conveyer bottom or floor being so arranged as to entirely cover and protect all of the wearing surfaces or articulating parts.

Figure 1 is a plan of a portion of a conveyer containing my improvements. Fig. 2 is a side view of the same. Fig. 3 is a longitudinal section. Fig. 4 shows the position of the parts, when going around a wheel. Fig. 5 is a plan view similar to that in Fig. 1 except that parts of the floor are broken away to show the supports directly beneath.

In the drawings, A, A, represent the side bars, and B, B, the end bars of the links of a carrier chain adapted to have the conveyer sections secured thereto. The side bars of each link are separable from each other, and each bar has a central wider part a , a reduced part a' at one end, and a curved edge a^2 , at the other. They are cast with horizontally expanded plates B' at the top, which extend in both directions. Each link of the chain is articulated to the next by a hinge pintle C,

passing through the end bar of one link, and through the overlapping perforated side bars A, of the next, the end bars B being hollow. Around each hinge pintle, there is an anti-friction roller C' which extends down somewhat below the bottom edges of the side bars. The rollers can be fitted snugly to the hollow end bars B, and the latter will relieve the pintles C from wear. Each link of the chain is a counterpart of the others, and hence the conveyer is to be distinguished from those having chains in which the links alternate as single bar and double bar links. With the latter chains, anti-friction supporting devices like the present rollers cannot be applied unless the pintles or other bars are extended out laterally; whereas in the present construction the chain links themselves without the addition of any supplemental parts are utilized for such support, and therefore each link can move in its path, without friction, and can be independent of the opposite links in the chain on the other side of the conveyer.

Upon the carrier links are fastened, or to them are secured the floor sections or conveying plates D, D. Each of these has a flat portion at d and a downwardly or inwardly turned part d' . The line of curve of the latter approximates the arc of a circle (when seen in section) struck from the axis of articulation as the center; and the curve starts about the line m where the plane of the flat part d intersects the vertical plane through the pintle axis. These conveyer sections are shown as made of sheet metal, and the curved part d' has a recess at d^3 to receive more or less of the chain link, the bottom edge d^4 extending down considerably below the tops of the side bars A. As a result of this construction and arrangement of the floor sections D, I avoid recesses in the side bars A and can maintain a strong chain link.

By examining the drawings, it will be seen that the edge a^2 at the end of the side bar A is not concentric with the axis, there being a recess at a^4 between said edge and the curved part d' of the floor section D; and as the said part D is made of sheet metal, it can yield downward from the aforesaid line m , which is often necessary because of irregularity in the shapes or movements of the parts, and

insures such flexibility at all the places of articulation as to prevent breakage. The end d^2 of one plane or floor section fits as snugly as practical against the curved end d' of an adjacent section so that there shall be no openings or crevices for the downward passage of small particles. When the pans or conveyer sections are passing around a wheel the part d^2 of one remains in contact with the part d' of the next, and therefore up to the time of discharge, none of the material can crowd in between the sections. If, by accident, any particles should be forced between them, the spring or yielding capability of the part d' comes into play, and prevents breaking or straining of the parts, and as soon as such particles escape, a tight joint is formed.

It will be seen that I employ a chain which is particularly well adapted to attain some of the important purposes, as its links are counter-parts, rectangular, centrally open and adapted to have the rollers applied on lines directly beneath the load, the rollers extending down to lines below the bottom edges of the links so that they give a complete anti-friction support.

The floor sections are so shaped and arranged as to effectually prevent material from getting into the wearing or articulating parts of the rollers, and the latter have their axes so arranged that the rollers do not come in contact with the floor sections, although their peripheries drop below the bottom edges of the links, as aforesaid, to furnish a rolling support.

What I claim is—

1. In a conveyer, the combination of the continuous sheet metal bottom sections D, each having the main portion d , and the

curved part d' , the anti-friction rollers C' directly beneath the said floor sections, and the chain having counter-part centrally open links, each link having side bars formed with the expanded plates B' secured to said floor sections and said side bars being shaped as described to provide an open space at a^4 below the bent ends d' of the floor sections, and the pintles C each connecting two links and holding an anti-friction roller upon its axis between the side bars, substantially as set forth.

2. The combination, with the floor sections, having the downwardly extended ends or edges d' curved from the transverse line m , of the link bars, each hinged to the next and secured to one of said sections, and having its end edge which is below the curved part of the section cut-off substantially as set forth to leave a free space at a^4 , substantially as set forth.

3. In a conveyer, the combination with the floor sections having downwardly turned ends or edges d' , the chain having its links secured to the said floor sections respectively and pivotally connected to each other, and the rollers situated beneath the downwardly turned portions of the floor sections and mounted on the cross bars of the links, said rollers being out of contact with the floor sections and extending below the bottom lines of the chain links, substantially as set forth.

In testimony whereof I affix my signature in presence of two witnesses.

JOHN H. FRANKLIN.

Witnesses:

FRED H. CROUGHTON,
SAMUEL RYLAND.