



(51) International Patent Classification:
H04B 7/06 (2006.01)

(21) International Application Number:
PCT/CN2023/111647

(22) International Filing Date:
08 August 2023 (08.08.2023)

(25) Filing Language: English

(26) Publication Language: English

(71) Applicant: **QUALCOMM INCORPORATED** [US/US];
Attn: International IP Administration, 5775 Morehouse Drive,
San Diego, California 92121-1714 (US).

(72) Inventors; and

(71) Applicants (*for WS only*): **PEZESHKI, Hamed** [IR/US]; 5775 Morehouse Drive, San Diego, California 92121-1714 (US). **TAHERZADEH BOROJENI, Mahmoud** [CA/US]; 5775 Morehouse Drive, San Diego, California 92121-1714 (US). **LI, Qiaoyu** [CN/CN]; 5775 Morehouse Drive, San Diego, California 92121-1714 (US). **MARZBAN, Mohamed Fouad Ahmed** [EG/US]; 5775 Morehouse Drive, San Diego, California 92121-1714 (US).

(74) Agent: **NTD PATENT & TRADEMARK AGENCY LTD.**; 10th Floor, Tower C, Beijing Global Trade Center,

36 North Third Ring Road East, Dongcheng District, Beijing 100013 (CN).

(81) Designated States (*unless otherwise indicated, for every kind of national protection available*): AE, AG, AL, AM, AO, AT, AU, AZ, BA, BB, BG, BH, BN, BR, BW, BY, BZ, CA, CH, CL, CN, CO, CR, CU, CV, CZ, DE, DJ, DK, DM, DO, DZ, EC, EE, EG, ES, FI, GB, GD, GE, GH, GM, GT, HN, HR, HU, ID, IL, IN, IQ, IR, IS, IT, JM, JO, JP, KE, KG, KH, KN, KP, KR, KW, KZ, LA, LC, LK, LR, LS, LU, LY, MA, MD, MG, MK, MN, MU, MW, MX, MY, MZ, NA, NG, NI, NO, NZ, OM, PA, PE, PG, PH, PL, PT, QA, RO, RS, RU, RW, SA, SC, SD, SE, SG, SK, SL, ST, SV, SY, TH, TJ, TM, TN, TR, TT, TZ, UA, UG, US, UZ, VC, VN, WS, ZA, ZM, ZW.

(84) Designated States (*unless otherwise indicated, for every kind of regional protection available*): ARIPO (BW, CV, GH, GM, KE, LR, LS, MW, MZ, NA, RW, SC, SD, SL, ST, SZ, TZ, UG, ZM, ZW), Eurasian (AM, AZ, BY, KG, KZ, RU, TJ, TM), European (AL, AT, BE, BG, CH, CY, CZ, DE, DK, EE, ES, FI, FR, GB, GR, HR, HU, IE, IS, IT, LT, LU, LV, MC, ME, MK, MT, NL, NO, PL, PT, RO, RS, SE, SI, SK, SM, TR), OAPI (BF, BJ, CF, CG, CI, CM, GA, GN, GQ, GW, KM, ML, MR, NE, SN, TD, TG).

(54) Title: ASSISTANCE INFORMATION FROM NETWORK TO UE FOR PREDICTIVE BEAM MANAGEMENT

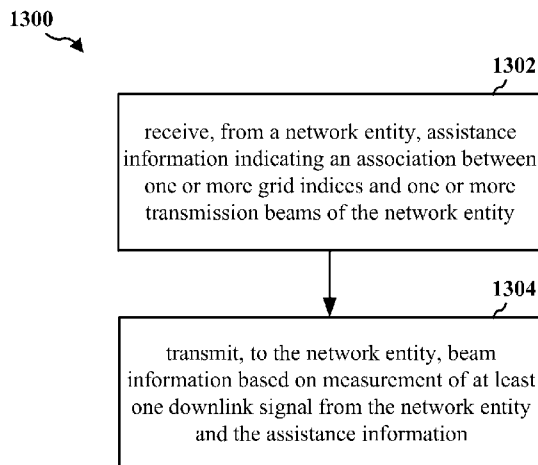

(57) Abstract: Method and apparatus for assistance information for predictive beam management. The apparatus receives, from a network entity, assistance information indicating an association between one or more grid indices and one or more transmission beams of the network entity. The apparatus transmits, to the network entity, beam information based on measurement of at least one downlink signal from the network entity and the assistance information. The apparatus measures at least one downlink signal from the network entity using a first set of beams to make a prediction for a second set of beams based on a beam prediction procedure. The apparatus receives, from the network entity, an indication comprising a subset of beams of the one or more transmission beams in response to transmission of the beam information. The apparatus transmits, to the network entity, a measurement report of the subset of beams of the one or more transmission beams.

FIG. 13



Declarations under Rule 4.17:

— *of inventorship (Rule 4.17(iv))*

Published:

— *with international search report (Art. 21(3))*

ASSISTANCE INFORMATION FROM NETWORK TO UE FOR PREDICTIVE BEAM MANAGEMENT

TECHNICAL FIELD

[0001] The present disclosure relates generally to communication systems, and more particularly, to a configuration for predictive beam management based on assistance information from a network.

INTRODUCTION

[0002] Wireless communication systems are widely deployed to provide various telecommunication services such as telephony, video, data, messaging, and broadcasts. Typical wireless communication systems may employ multiple-access technologies capable of supporting communication with multiple users by sharing available system resources. Examples of such multiple-access technologies include code division multiple access (CDMA) systems, time division multiple access (TDMA) systems, frequency division multiple access (FDMA) systems, orthogonal frequency division multiple access (OFDMA) systems, single-carrier frequency division multiple access (SC-FDMA) systems, and time division synchronous code division multiple access (TD-SCDMA) systems.

[0003] These multiple access technologies have been adopted in various telecommunication standards to provide a common protocol that enables different wireless devices to communicate on a municipal, national, regional, and even global level. An example telecommunication standard is 5G New Radio (NR). 5G NR is part of a continuous mobile broadband evolution promulgated by Third Generation Partnership Project (3GPP) to meet new requirements associated with latency, reliability, security, scalability (e.g., with Internet of Things (IoT)), and other requirements. 5G NR includes services associated with enhanced mobile broadband (eMBB), massive machine type communications (mMTC), and ultra-reliable low latency communications (URLLC). Some aspects of 5G NR may be based on the 4G Long Term Evolution (LTE) standard. There exists a need for further improvements in 5G NR technology. These improvements may also be applicable to other multi-access technologies and the telecommunication standards that employ these technologies.

BRIEF SUMMARY

- [0004] The following presents a simplified summary of one or more aspects in order to provide a basic understanding of such aspects. This summary is not an extensive overview of all contemplated aspects. This summary neither identifies key or critical elements of all aspects nor delineates the scope of any or all aspects. Its sole purpose is to present some concepts of one or more aspects in a simplified form as a prelude to the more detailed description that is presented later.
- [0005] In an aspect of the disclosure, a method, a computer-readable medium, and an apparatus are provided. The apparatus receives, from a network entity, assistance information indicating an association between one or more grid indices and one or more transmission beams of the network entity. The apparatus transmits, to the network entity, beam information based on measurement of at least one downlink signal from the network entity and the assistance information.
- [0006] In an aspect of the disclosure, a method, a computer-readable medium, and an apparatus are provided. The apparatus may be a device at a network node. The device may be a processor and/or a modem at a network node or the network node itself. The apparatus provides, to a user equipment (UE), assistance information indicating an association between one or more grid indices and one or more transmission beams of the network entity. The apparatus obtains, from the UE, beam information based on measurement of at least one downlink signal from the network entity and the assistance information.
- [0007] To the accomplishment of the foregoing and related ends, the one or more aspects may include the features hereinafter fully described and particularly pointed out in the claims. The following description and the drawings set forth in detail certain illustrative features of the one or more aspects. These features are indicative, however, of but a few of the various ways in which the principles of various aspects may be employed.

BRIEF DESCRIPTION OF THE DRAWINGS

- [0008] FIG. 1 is a diagram illustrating an example of a wireless communications system and an access network.
- [0009] FIG. 2A is a diagram illustrating an example of a first frame, in accordance with various aspects of the present disclosure.

- [0010] FIG. 2B is a diagram illustrating an example of downlink (DL) channels within a subframe, in accordance with various aspects of the present disclosure.
- [0011] FIG. 2C is a diagram illustrating an example of a second frame, in accordance with various aspects of the present disclosure.
- [0012] FIG. 2D is a diagram illustrating an example of uplink (UL) channels within a subframe, in accordance with various aspects of the present disclosure.
- [0013] FIG. 3 is a diagram illustrating an example of a base station and user equipment (UE) in an access network.
- [0014] FIG. 4A is a diagram illustrating an example of an artificial intelligence (AI)/machine learning (ML) algorithm.
- [0015] FIG. 4B is a diagram illustrating an example of a spatial beam prediction using an AI/ML algorithm.
- [0016] FIG. 5 is a diagram illustrating an example of temporal beam predictions.
- [0017] FIG. 6 is a diagram illustrating an example of a beam prediction.
- [0018] FIG. 7 is a diagram illustrating an example of a beam prediction.
- [0019] FIG. 8 is a diagram illustrating an example of a grid indexing at a network entity.
- [0020] FIG. 9 is a diagram illustrating an example of a grid index.
- [0021] FIG. 10 is a diagram illustrating an example of a grid index.
- [0022] FIG. 11 is a diagram illustrating an example of a grid index.
- [0023] FIG. 12 is a call flow diagram of signaling between a UE and a base station.
- [0024] FIG. 13 is a flowchart of a method of wireless communication.
- [0025] FIG. 14 is a flowchart of a method of wireless communication.
- [0026] FIG. 15 is a diagram illustrating an example of a hardware implementation for an example apparatus and/or network entity.
- [0027] FIG. 16 is a flowchart of a method of wireless communication.
- [0028] FIG. 17 is a flowchart of a method of wireless communication.
- [0029] FIG. 18 is a diagram illustrating an example of a hardware implementation for an example network entity.

DETAILED DESCRIPTION

- [0030] Artificial intelligence (AI) and/or machine learning (ML) may be utilized for beam prediction. For example, a first set of beams (e.g., Set B) may be a set of beams whose measurements are taken as inputs of the AI/ML model. A second set of beams (e.g.,

Set A) may be a set of beams from which the AI/ML model performs predictions (at the output of AI/ML model). Assistance information from the network to the UE for a UE-side AI/ML model may provide assistance for beam predictions. For example, the assistance information may include network side beam shape information (e.g., 3dB beamwidth, beam boresight directions, beam shape, transmission beam angle, etc.). In UE-side AI/ML models, layer 1 (L1) reference signal receive power (RSRP) may be enhanced. For example, a UE-side AI/ML model for beam predictions may comprise L1 signaling to report information of the AI/ML model inference to the network, such as but not limited to, beams that are based on the output of the AI/ML model inference, beams of future time instances that are based on an output of the AI/ML model inference, or information about timing corresponding to reported beams. Beam prediction by the UE may have reduced or sub-optimal performance in the absence of assistance information related to downlink transmission beams of the network entity.

- [0031]** Aspects presented herein provide a configuration for beam-related assistance information for UE side modeling. For example, a UE may receive assistance information from a network entity that indicates an association between one or more grid indices and one or more transmission beams from the network entity to predict a set of beams based on a beam prediction procedure.
- [0032]** The detailed description set forth below in connection with the drawings describes various configurations and does not represent the only configurations in which the concepts described herein may be practiced. The detailed description includes specific details for the purpose of providing a thorough understanding of various concepts. However, these concepts may be practiced without these specific details. In some instances, well known structures and components are shown in block diagram form in order to avoid obscuring such concepts.
- [0033]** Several aspects of telecommunication systems are presented with reference to various apparatus and methods. These apparatus and methods are described in the following detailed description and illustrated in the accompanying drawings by various blocks, components, circuits, processes, algorithms, etc. (collectively referred to as “elements”). These elements may be implemented using electronic hardware, computer software, or any combination thereof. Whether such elements are

implemented as hardware or software depends upon the particular application and design constraints imposed on the overall system.

[0034] By way of example, an element, or any portion of an element, or any combination of elements may be implemented as a “processing system” that includes one or more processors. When multiple processors are implemented, the multiple processors may perform the functions individually or in combination. Examples of processors include microprocessors, microcontrollers, graphics processing units (GPUs), central processing units (CPUs), application processors, digital signal processors (DSPs), reduced instruction set computing (RISC) processors, systems on a chip (SoC), baseband processors, field programmable gate arrays (FPGAs), programmable logic devices (PLDs), state machines, gated logic, discrete hardware circuits, and other suitable hardware configured to perform the various functionality described throughout this disclosure. One or more processors in the processing system may execute software. Software, whether referred to as software, firmware, middleware, microcode, hardware description language, or otherwise, shall be construed broadly to mean instructions, instruction sets, code, code segments, program code, programs, subprograms, software components, applications, software applications, software packages, routines, subroutines, objects, executables, threads of execution, procedures, functions, or any combination thereof.

[0035] Accordingly, in one or more example aspects, implementations, and/or use cases, the functions described may be implemented in hardware, software, or any combination thereof. If implemented in software, the functions may be stored on or encoded as one or more instructions or code on a computer-readable medium. Computer-readable media includes computer storage media. Storage media may be any available media that can be accessed by a computer. By way of example, such computer-readable media can include a random-access memory (RAM), a read-only memory (ROM), an electrically erasable programmable ROM (EEPROM), optical disk storage, magnetic disk storage, other magnetic storage devices, combinations of the types of computer-readable media, or any other medium that can be used to store computer executable code in the form of instructions or data structures that can be accessed by a computer.

[0036] While aspects, implementations, and/or use cases are described in this application by illustration to some examples, additional or different aspects, implementations and/or use cases may come about in many different arrangements and scenarios. Aspects,

implementations, and/or use cases described herein may be implemented across many differing platform types, devices, systems, shapes, sizes, and packaging arrangements. For example, aspects, implementations, and/or use cases may come about via integrated chip implementations and other non-module-component based devices (e.g., end-user devices, vehicles, communication devices, computing devices, industrial equipment, retail/purchasing devices, medical devices, artificial intelligence (AI)-enabled devices, etc.). While some examples may or may not be specifically directed to use cases or applications, a wide assortment of applicability of described examples may occur. Aspects, implementations, and/or use cases may range a spectrum from chip-level or modular components to non-modular, non-chip-level implementations and further to aggregate, distributed, or original equipment manufacturer (OEM) devices or systems incorporating one or more techniques herein. In some practical settings, devices incorporating described aspects and features may also include additional components and features for implementation and practice of claimed and described aspect. For example, transmission and reception of wireless signals necessarily includes a number of components for analog and digital purposes (e.g., hardware components including antenna, RF-chains, power amplifiers, modulators, buffer, processor(s), interleaver, adders/summers, etc.). Techniques described herein may be practiced in a wide variety of devices, chip-level components, systems, distributed arrangements, aggregated or disaggregated components, end-user devices, etc. of varying sizes, shapes, and constitution.

[0037] Deployment of communication systems, such as 5G NR systems, may be arranged in multiple manners with various components or constituent parts. In a 5G NR system, or network, a network node, a network entity, a mobility element of a network, a radio access network (RAN) node, a core network node, a network element, or a network equipment, such as a base station (BS), or one or more units (or one or more components) performing base station functionality, may be implemented in an aggregated or disaggregated architecture. For example, a BS (such as a Node B (NB), evolved NB (eNB), NR BS, 5G NB, access point (AP), a transmission reception point (TRP), or a cell, etc.) may be implemented as an aggregated base station (also known as a standalone BS or a monolithic BS) or a disaggregated base station.

[0038] An aggregated base station may be configured to utilize a radio protocol stack that is physically or logically integrated within a single RAN node. A disaggregated base

station may be configured to utilize a protocol stack that is physically or logically distributed among two or more units (such as one or more central or centralized units (CUs), one or more distributed units (DUs), or one or more radio units (RUs)). In some aspects, a CU may be implemented within a RAN node, and one or more DUs may be co-located with the CU, or alternatively, may be geographically or virtually distributed throughout one or multiple other RAN nodes. The DUs may be implemented to communicate with one or more RUs. Each of the CU, DU and RU can be implemented as virtual units, i.e., a virtual central unit (VCU), a virtual distributed unit (VDU), or a virtual radio unit (VRU).

[0039] Base station operation or network design may consider aggregation characteristics of base station functionality. For example, disaggregated base stations may be utilized in an integrated access backhaul (IAB) network, an open radio access network (O-RAN (such as the network configuration sponsored by the O-RAN Alliance)), or a virtualized radio access network (vRAN, also known as a cloud radio access network (C-RAN)). Disaggregation may include distributing functionality across two or more units at various physical locations, as well as distributing functionality for at least one unit virtually, which can enable flexibility in network design. The various units of the disaggregated base station, or disaggregated RAN architecture, can be configured for wired or wireless communication with at least one other unit.

[0040] FIG. 1 is a diagram 100 illustrating an example of a wireless communications system and an access network. The illustrated wireless communications system includes a disaggregated base station architecture. The disaggregated base station architecture may include one or more CUs 110 that can communicate directly with a core network 120 via a backhaul link, or indirectly with the core network 120 through one or more disaggregated base station units (such as a Near-Real Time (Near-RT) RAN Intelligent Controller (RIC) 125 via an E2 link, or a Non-Real Time (Non-RT) RIC 115 associated with a Service Management and Orchestration (SMO) Framework 105, or both). A CU 110 may communicate with one or more DUs 130 via respective midhaul links, such as an F1 interface. The DUs 130 may communicate with one or more RUs 140 via respective fronthaul links. The RUs 140 may communicate with respective UEs 104 via one or more radio frequency (RF) access links. In some implementations, the UE 104 may be simultaneously served by multiple RUs 140.

- [0041]** Each of the units, i.e., the CUs 110, the DUs 130, the RUs 140, as well as the Near-RT RICs 125, the Non-RT RICs 115, and the SMO Framework 105, may include one or more interfaces or be coupled to one or more interfaces configured to receive or to transmit signals, data, or information (collectively, signals) via a wired or wireless transmission medium. Each of the units, or an associated processor or controller providing instructions to the communication interfaces of the units, can be configured to communicate with one or more of the other units via the transmission medium. For example, the units can include a wired interface configured to receive or to transmit signals over a wired transmission medium to one or more of the other units. Additionally, the units can include a wireless interface, which may include a receiver, a transmitter, or a transceiver (such as an RF transceiver), configured to receive or to transmit signals, or both, over a wireless transmission medium to one or more of the other units.
- [0042]** In some aspects, the CU 110 may host one or more higher layer control functions. Such control functions can include radio resource control (RRC), packet data convergence protocol (PDCP), service data adaptation protocol (SDAP), or the like. Each control function can be implemented with an interface configured to communicate signals with other control functions hosted by the CU 110. The CU 110 may be configured to handle user plane functionality (i.e., Central Unit – User Plane (CU-UP)), control plane functionality (i.e., Central Unit – Control Plane (CU-CP)), or a combination thereof. In some implementations, the CU 110 can be logically split into one or more CU-UP units and one or more CU-CP units. The CU-UP unit can communicate bidirectionally with the CU-CP unit via an interface, such as an E1 interface when implemented in an O-RAN configuration. The CU 110 can be implemented to communicate with the DU 130, as necessary, for network control and signaling.
- [0043]** The DU 130 may correspond to a logical unit that includes one or more base station functions to control the operation of one or more RUs 140. In some aspects, the DU 130 may host one or more of a radio link control (RLC) layer, a medium access control (MAC) layer, and one or more high physical (PHY) layers (such as modules for forward error correction (FEC) encoding and decoding, scrambling, modulation, demodulation, or the like) depending, at least in part, on a functional split, such as those defined by 3GPP. In some aspects, the DU 130 may further host one or more

low PHY layers. Each layer (or module) can be implemented with an interface configured to communicate signals with other layers (and modules) hosted by the DU 130, or with the control functions hosted by the CU 110.

[0044] Lower-layer functionality can be implemented by one or more RUs 140. In some deployments, an RU 140, controlled by a DU 130, may correspond to a logical node that hosts RF processing functions, or low-PHY layer functions (such as performing fast Fourier transform (FFT), inverse FFT (iFFT), digital beamforming, physical random access channel (PRACH) extraction and filtering, or the like), or both, based at least in part on the functional split, such as a lower layer functional split. In such an architecture, the RU(s) 140 can be implemented to handle over the air (OTA) communication with one or more UEs 104. In some implementations, real-time and non-real-time aspects of control and user plane communication with the RU(s) 140 can be controlled by the corresponding DU 130. In some scenarios, this configuration can enable the DU(s) 130 and the CU 110 to be implemented in a cloud-based RAN architecture, such as a vRAN architecture.

[0045] The SMO Framework 105 may be configured to support RAN deployment and provisioning of non-virtualized and virtualized network elements. For non-virtualized network elements, the SMO Framework 105 may be configured to support the deployment of dedicated physical resources for RAN coverage requirements that may be managed via an operations and maintenance interface (such as an O1 interface). For virtualized network elements, the SMO Framework 105 may be configured to interact with a cloud computing platform (such as an open cloud (O-Cloud) 190) to perform network element life cycle management (such as to instantiate virtualized network elements) via a cloud computing platform interface (such as an O2 interface). Such virtualized network elements can include, but are not limited to, CUs 110, DUs 130, RUs 140 and Near-RT RICs 125. In some implementations, the SMO Framework 105 can communicate with a hardware aspect of a 4G RAN, such as an open eNB (O-eNB) 111, via an O1 interface. Additionally, in some implementations, the SMO Framework 105 can communicate directly with one or more RUs 140 via an O1 interface. The SMO Framework 105 also may include a Non-RT RIC 115 configured to support functionality of the SMO Framework 105.

[0046] The Non-RT RIC 115 may be configured to include a logical function that enables non-real-time control and optimization of RAN elements and resources, artificial

intelligence (AI) / machine learning (ML) (AI/ML) workflows including model training and updates, or policy-based guidance of applications/features in the Near-RT RIC 125. The Non-RT RIC 115 may be coupled to or communicate with (such as via an A1 interface) the Near-RT RIC 125. The Near-RT RIC 125 may be configured to include a logical function that enables near-real-time control and optimization of RAN elements and resources via data collection and actions over an interface (such as via an E2 interface) connecting one or more CUs 110, one or more DUs 130, or both, as well as an O-eNB, with the Near-RT RIC 125.

[0047] In some implementations, to generate AI/ML models to be deployed in the Near-RT RIC 125, the Non-RT RIC 115 may receive parameters or external enrichment information from external servers. Such information may be utilized by the Near-RT RIC 125 and may be received at the SMO Framework 105 or the Non-RT RIC 115 from non-network data sources or from network functions. In some examples, the Non-RT RIC 115 or the Near-RT RIC 125 may be configured to tune RAN behavior or performance. For example, the Non-RT RIC 115 may monitor long-term trends and patterns for performance and employ AI/ML models to perform corrective actions through the SMO Framework 105 (such as reconfiguration via O1) or via creation of RAN management policies (such as A1 policies).

[0048] At least one of the CU 110, the DU 130, and the RU 140 may be referred to as a base station 102. Accordingly, a base station 102 may include one or more of the CU 110, the DU 130, and the RU 140 (each component indicated with dotted lines to signify that each component may or may not be included in the base station 102). The base station 102 provides an access point to the core network 120 for a UE 104. The base station 102 may include macrocells (high power cellular base station) and/or small cells (low power cellular base station). The small cells include femtocells, picocells, and microcells. A network that includes both small cell and macrocells may be known as a heterogeneous network. A heterogeneous network may also include Home Evolved Node Bs (eNBs) (HeNBs), which may provide service to a restricted group known as a closed subscriber group (CSG). The communication links between the RUs 140 and the UEs 104 may include uplink (UL) (also referred to as reverse link) transmissions from a UE 104 to an RU 140 and/or downlink (DL) (also referred to as forward link) transmissions from an RU 140 to a UE 104. The communication links may use multiple-input and multiple-output (MIMO) antenna technology, including

spatial multiplexing, beamforming, and/or transmit diversity. The communication links may be through one or more carriers. The base station 102 / UEs 104 may use spectrum up to Y MHz (e.g., 5, 10, 15, 20, 100, 400, etc. MHz) bandwidth per carrier allocated in a carrier aggregation of up to a total of Yx MHz (x component carriers) used for transmission in each direction. The carriers may or may not be adjacent to each other. Allocation of carriers may be asymmetric with respect to DL and UL (e.g., more or fewer carriers may be allocated for DL than for UL). The component carriers may include a primary component carrier and one or more secondary component carriers. A primary component carrier may be referred to as a primary cell (PCell) and a secondary component carrier may be referred to as a secondary cell (SCell).

[0049] Certain UEs 104 may communicate with each other using device-to-device (D2D) communication link 158. The D2D communication link 158 may use the DL/UL wireless wide area network (WWAN) spectrum. The D2D communication link 158 may use one or more sidelink channels, such as a physical sidelink broadcast channel (PSBCH), a physical sidelink discovery channel (PSDCH), a physical sidelink shared channel (PSSCH), and a physical sidelink control channel (PSCCH). D2D communication may be through a variety of wireless D2D communications systems, such as for example, Bluetooth™ (Bluetooth is a trademark of the Bluetooth Special Interest Group (SIG)), Wi-Fi™ (Wi-Fi is a trademark of the Wi-Fi Alliance) based on the Institute of Electrical and Electronics Engineers (IEEE) 802.11 standard, LTE, or NR.

[0050] The wireless communications system may further include a Wi-Fi AP 150 in communication with UEs 104 (also referred to as Wi-Fi stations (STAs)) via communication link 154, e.g., in a 5 GHz unlicensed frequency spectrum or the like. When communicating in an unlicensed frequency spectrum, the UEs 104 / AP 150 may perform a clear channel assessment (CCA) prior to communicating in order to determine whether the channel is available.

[0051] The electromagnetic spectrum is often subdivided, based on frequency/wavelength, into various classes, bands, channels, etc. In 5G NR, two initial operating bands have been identified as frequency range designations FR1 (410 MHz – 7.125 GHz) and FR2 (24.25 GHz – 52.6 GHz). Although a portion of FR1 is greater than 6 GHz, FR1 is often referred to (interchangeably) as a “sub-6 GHz” band in various documents and articles. A similar nomenclature issue sometimes occurs with regard to FR2,

which is often referred to (interchangeably) as a “millimeter wave” band in documents and articles, despite being different from the extremely high frequency (EHF) band (30 GHz – 300 GHz) which is identified by the International Telecommunications Union (ITU) as a “millimeter wave” band.

[0052] The frequencies between FR1 and FR2 are often referred to as mid-band frequencies. Recent 5G NR studies have identified an operating band for these mid-band frequencies as frequency range designation FR3 (7.125 GHz – 24.25 GHz). Frequency bands falling within FR3 may inherit FR1 characteristics and/or FR2 characteristics, and thus may effectively extend features of FR1 and/or FR2 into mid-band frequencies. In addition, higher frequency bands are currently being explored to extend 5G NR operation beyond 52.6 GHz. For example, three higher operating bands have been identified as frequency range designations FR2-2 (52.6 GHz – 71 GHz), FR4 (71 GHz – 114.25 GHz), and FR5 (114.25 GHz – 300 GHz). Each of these higher frequency bands falls within the EHF band.

[0053] With the above aspects in mind, unless specifically stated otherwise, the term “sub-6 GHz” or the like if used herein may broadly represent frequencies that may be less than 6 GHz, may be within FR1, or may include mid-band frequencies. Further, unless specifically stated otherwise, the term “millimeter wave” or the like if used herein may broadly represent frequencies that may include mid-band frequencies, may be within FR2, FR4, FR2-2, and/or FR5, or may be within the EHF band.

[0054] The base station 102 and the UE 104 may each include a plurality of antennas, such as antenna elements, antenna panels, and/or antenna arrays to facilitate beamforming. The base station 102 may transmit a beamformed signal 182 to the UE 104 in one or more transmit directions. The UE 104 may receive the beamformed signal from the base station 102 in one or more receive directions. The UE 104 may also transmit a beamformed signal 184 to the base station 102 in one or more transmit directions. The base station 102 may receive the beamformed signal from the UE 104 in one or more receive directions. The base station 102 / UE 104 may perform beam training to determine the best receive and transmit directions for each of the base station 102 / UE 104. The transmit and receive directions for the base station 102 may or may not be the same. The transmit and receive directions for the UE 104 may or may not be the same.

[0055] The base station 102 may include and/or be referred to as a gNB, Node B, eNB, an access point, a base transceiver station, a radio base station, a radio transceiver, a transceiver function, a basic service set (BSS), an extended service set (ESS), a TRP, network node, network entity, network equipment, or some other suitable terminology. The base station 102 can be implemented as an integrated access and backhaul (IAB) node, a relay node, a sidelink node, an aggregated (monolithic) base station with a baseband unit (BBU) (including a CU and a DU) and an RU, or as a disaggregated base station including one or more of a CU, a DU, and/or an RU. The set of base stations, which may include disaggregated base stations and/or aggregated base stations, may be referred to as next generation (NG) RAN (NG-RAN).

[0056] The core network 120 may include an Access and Mobility Management Function (AMF) 161, a Session Management Function (SMF) 162, a User Plane Function (UPF) 163, a Unified Data Management (UDM) 164, one or more location servers 168, and other functional entities. The AMF 161 is the control node that processes the signaling between the UEs 104 and the core network 120. The AMF 161 supports registration management, connection management, mobility management, and other functions. The SMF 162 supports session management and other functions. The UPF 163 supports packet routing, packet forwarding, and other functions. The UDM 164 supports the generation of authentication and key agreement (AKA) credentials, user identification handling, access authorization, and subscription management. The one or more location servers 168 are illustrated as including a Gateway Mobile Location Center (GMLC) 165 and a Location Management Function (LMF) 166. However, generally, the one or more location servers 168 may include one or more location/positioning servers, which may include one or more of the GMLC 165, the LMF 166, a position determination entity (PDE), a serving mobile location center (SMLC), a mobile positioning center (MPC), or the like. The GMLC 165 and the LMF 166 support UE location services. The GMLC 165 provides an interface for clients/applications (e.g., emergency services) for accessing UE positioning information. The LMF 166 receives measurements and assistance information from the NG-RAN and the UE 104 via the AMF 161 to compute the position of the UE 104. The NG-RAN may utilize one or more positioning methods in order to determine the position of the UE 104. Positioning the UE 104 may involve signal measurements, a position estimate, and an optional velocity computation based on the measurements.

The signal measurements may be made by the UE 104 and/or the base station 102 serving the UE 104. The signals measured may be based on one or more of a satellite positioning system (SPS) 170 (e.g., one or more of a Global Navigation Satellite System (GNSS), global position system (GPS), non-terrestrial network (NTN), or other satellite position/location system), LTE signals, wireless local area network (WLAN) signals, Bluetooth signals, a terrestrial beacon system (TBS), sensor-based information (e.g., barometric pressure sensor, motion sensor), NR enhanced cell ID (NR E-CID) methods, NR signals (e.g., multi-round trip time (Multi-RTT), DL angle-of-departure (DL-AoD), DL time difference of arrival (DL-TDOA), UL time difference of arrival (UL-TDOA), and UL angle-of-arrival (UL-AoA) positioning), and/or other systems/signals/sensors.

[0057] Examples of UEs 104 include a cellular phone, a smart phone, a session initiation protocol (SIP) phone, a laptop, a personal digital assistant (PDA), a satellite radio, a global positioning system, a multimedia device, a video device, a digital audio player (e.g., MP3 player), a camera, a game console, a tablet, a smart device, a wearable device, a vehicle, an electric meter, a gas pump, a large or small kitchen appliance, a healthcare device, an implant, a sensor/actuator, a display, or any other similar functioning device. Some of the UEs 104 may be referred to as IoT devices (e.g., parking meter, gas pump, toaster, vehicles, heart monitor, etc.). The UE 104 may also be referred to as a station, a mobile station, a subscriber station, a mobile unit, a subscriber unit, a wireless unit, a remote unit, a mobile device, a wireless device, a wireless communications device, a remote device, a mobile subscriber station, an access terminal, a mobile terminal, a wireless terminal, a remote terminal, a handset, a user agent, a mobile client, a client, or some other suitable terminology. In some scenarios, the term UE may also apply to one or more companion devices such as in a device constellation arrangement. One or more of these devices may collectively access the network and/or individually access the network.

[0058] Referring again to FIG. 1, in certain aspects, the UE 104 may comprise a beam component 198 that may be configured to receive, from a network entity, assistance information indicating an association between one or more grid indices and one or more transmission beams of the network entity; and transmit, to the network entity, beam information based on measurement of at least one downlink signal from the network entity and the assistance information.

- [0059] Referring again to FIG. 1, in certain aspects, the base station 102 may comprise a beam component 199 that may be configured to provide, to a user equipment (UE), assistance information indicating an association between one or more grid indices and one or more transmission beams of the network entity; and obtaining, from the UE, beam information based on measurement of at least one downlink signal from the network entity and the assistance information.
- [0060] Although the following description may be focused on 5G NR, the concepts described herein may be applicable to other similar areas, such as LTE, LTE-A, CDMA, GSM, and other wireless technologies.
- [0061] FIG. 2A is a diagram 200 illustrating an example of a first subframe within a 5G NR frame structure. FIG. 2B is a diagram 230 illustrating an example of DL channels within a 5G NR subframe. FIG. 2C is a diagram 250 illustrating an example of a second subframe within a 5G NR frame structure. FIG. 2D is a diagram 280 illustrating an example of UL channels within a 5G NR subframe. The 5G NR frame structure may be frequency division duplexed (FDD) in which for a particular set of subcarriers (carrier system bandwidth), subframes within the set of subcarriers are dedicated for either DL or UL, or may be time division duplexed (TDD) in which for a particular set of subcarriers (carrier system bandwidth), subframes within the set of subcarriers are dedicated for both DL and UL. In the examples provided by FIGs. 2A, 2C, the 5G NR frame structure is assumed to be TDD, with subframe 4 being configured with slot format 28 (with mostly DL), where D is DL, U is UL, and F is flexible for use between DL/UL, and subframe 3 being configured with slot format 1 (with all UL). While subframes 3, 4 are shown with slot formats 1, 28, respectively, any particular subframe may be configured with any of the various available slot formats 0-61. Slot formats 0, 1 are all DL, UL, respectively. Other slot formats 2-61 include a mix of DL, UL, and flexible symbols. UEs are configured with the slot format (dynamically through DL control information (DCI), or semi-statically/statically through radio resource control (RRC) signaling) through a received slot format indicator (SFI). Note that the description *infra* applies also to a 5G NR frame structure that is TDD.
- [0062] FIGs. 2A-2D illustrate a frame structure, and the aspects of the present disclosure may be applicable to other wireless communication technologies, which may have a different frame structure and/or different channels. A frame (10 ms) may be divided

into 10 equally sized subframes (1 ms). Each subframe may include one or more time slots. Subframes may also include mini-slots, which may include 7, 4, or 2 symbols. Each slot may include 14 or 12 symbols, depending on whether the cyclic prefix (CP) is normal or extended. For normal CP, each slot may include 14 symbols, and for extended CP, each slot may include 12 symbols. The symbols on DL may be CP orthogonal frequency division multiplexing (OFDM) (CP-OFDM) symbols. The symbols on UL may be CP-OFDM symbols (for high throughput scenarios) or discrete Fourier transform (DFT) spread OFDM (DFT-s-OFDM) symbols (for power limited scenarios; limited to a single stream transmission). The number of slots within a subframe is based on the CP and the numerology. The numerology defines the subcarrier spacing (SCS) (see Table 1). The symbol length/duration may scale with $1/\text{SCS}$.

μ	SCS $\Delta f = 2^\mu \cdot 15[\text{kHz}]$	Cyclic prefix
0	15	Normal
1	30	Normal
2	60	Normal, Extended
3	120	Normal
4	240	Normal
5	480	Normal
6	960	Normal

Table 1: Numerology, SCS, and CP

[0063] For normal CP (14 symbols/slot), different numerologies μ 0 to 4 allow for 1, 2, 4, 8, and 16 slots, respectively, per subframe. For extended CP, the numerology 2 allows for 4 slots per subframe. Accordingly, for normal CP and numerology μ , there are 14 symbols/slot and 2^μ slots/subframe. The subcarrier spacing may be equal to $2^\mu \cdot 15$ kHz, where μ is the numerology 0 to 4. As such, the numerology $\mu=0$ has a subcarrier spacing of 15 kHz and the numerology $\mu=4$ has a subcarrier spacing of 240 kHz. The symbol length/duration is inversely related to the subcarrier spacing. FIGs. 2A-2D provide an example of normal CP with 14 symbols per slot and numerology $\mu=2$ with 4 slots per subframe. The slot duration is 0.25 ms, the subcarrier spacing is 60 kHz, and the symbol duration is approximately 16.67 μs . Within a set of frames,

there may be one or more different bandwidth parts (BWPs) (see FIG. 2B) that are frequency division multiplexed. Each BWP may have a particular numerology and CP (normal or extended).

[0064] A resource grid may be used to represent the frame structure. Each time slot includes a resource block (RB) (also referred to as physical RBs (PRBs)) that extends 12 consecutive subcarriers. The resource grid is divided into multiple resource elements (REs). The number of bits carried by each RE depends on the modulation scheme.

[0065] As illustrated in FIG. 2A, some of the REs carry reference (pilot) signals (RS) for the UE. The RS may include demodulation RS (DM-RS) (indicated as R for one particular configuration, but other DM-RS configurations are possible) and channel state information reference signals (CSI-RS) for channel estimation at the UE. The RS may also include beam measurement RS (BRS), beam refinement RS (BRRS), and phase tracking RS (PT-RS).

[0066] FIG. 2B illustrates an example of various DL channels within a subframe of a frame. The physical downlink control channel (PDCCH) carries DCI within one or more control channel elements (CCEs) (e.g., 1, 2, 4, 8, or 16 CCEs), each CCE including six RE groups (REGs), each REG including 12 consecutive REs in an OFDM symbol of an RB. A PDCCH within one BWP may be referred to as a control resource set (CORESET). A UE is configured to monitor PDCCH candidates in a PDCCH search space (e.g., common search space, UE-specific search space) during PDCCH monitoring occasions on the CORESET, where the PDCCH candidates have different DCI formats and different aggregation levels. Additional BWPs may be located at greater and/or lower frequencies across the channel bandwidth. A primary synchronization signal (PSS) may be within symbol 2 of particular subframes of a frame. The PSS is used by a UE 104 to determine subframe/symbol timing and a physical layer identity. A secondary synchronization signal (SSS) may be within symbol 4 of particular subframes of a frame. The SSS is used by a UE to determine a physical layer cell identity group number and radio frame timing. Based on the physical layer identity and the physical layer cell identity group number, the UE can determine a physical cell identifier (PCI). Based on the PCI, the UE can determine the locations of the DM-RS. The physical broadcast channel (PBCH), which carries a master information block (MIB), may be logically grouped with the PSS and SSS to form a synchronization signal (SS)/PBCH block (also referred to as SS block

(SSB)). The MIB provides a number of RBs in the system bandwidth and a system frame number (SFN). The physical downlink shared channel (PDSCH) carries user data, broadcast system information not transmitted through the PBCH such as system information blocks (SIBs), and paging messages.

[0067] As illustrated in FIG. 2C, some of the REs carry DM-RS (indicated as R for one particular configuration, but other DM-RS configurations are possible) for channel estimation at the base station. The UE may transmit DM-RS for the physical uplink control channel (PUCCH) and DM-RS for the physical uplink shared channel (PUSCH). The PUSCH DM-RS may be transmitted in the first one or two symbols of the PUSCH. The PUCCH DM-RS may be transmitted in different configurations depending on whether short or long PUCCHs are transmitted and depending on the particular PUCCH format used. The UE may transmit sounding reference signals (SRS). The SRS may be transmitted in the last symbol of a subframe. The SRS may have a comb structure, and a UE may transmit SRS on one of the combs. The SRS may be used by a base station for channel quality estimation to enable frequency-dependent scheduling on the UL.

[0068] FIG. 2D illustrates an example of various UL channels within a subframe of a frame. The PUCCH may be located as indicated in one configuration. The PUCCH carries uplink control information (UCI), such as scheduling requests, a channel quality indicator (CQI), a precoding matrix indicator (PMI), a rank indicator (RI), and hybrid automatic repeat request (HARQ) acknowledgment (ACK) (HARQ-ACK) feedback (i.e., one or more HARQ ACK bits indicating one or more ACK and/or negative ACK (NACK)). The PUSCH carries data, and may additionally be used to carry a buffer status report (BSR), a power headroom report (PHR), and/or UCI.

[0069] FIG. 3 is a block diagram of a base station 310 in communication with a UE 350 in an access network. In the DL, Internet protocol (IP) packets may be provided to a controller/processor 375. The controller/processor 375 implements layer 3 and layer 2 functionality. Layer 3 includes a radio resource control (RRC) layer, and layer 2 includes a service data adaptation protocol (SDAP) layer, a packet data convergence protocol (PDCP) layer, a radio link control (RLC) layer, and a medium access control (MAC) layer. The controller/processor 375 provides RRC layer functionality associated with broadcasting of system information (e.g., MIB, SIBs), RRC connection control (e.g., RRC connection paging, RRC connection establishment,

RRC connection modification, and RRC connection release), inter radio access technology (RAT) mobility, and measurement configuration for UE measurement reporting; PDCP layer functionality associated with header compression / decompression, security (ciphering, deciphering, integrity protection, integrity verification), and handover support functions; RLC layer functionality associated with the transfer of upper layer packet data units (PDUs), error correction through ARQ, concatenation, segmentation, and reassembly of RLC service data units (SDUs), re-segmentation of RLC data PDUs, and reordering of RLC data PDUs; and MAC layer functionality associated with mapping between logical channels and transport channels, multiplexing of MAC SDUs onto transport blocks (TBs), demultiplexing of MAC SDUs from TBs, scheduling information reporting, error correction through HARQ, priority handling, and logical channel prioritization.

[0070] The transmit (TX) processor 316 and the receive (RX) processor 370 implement layer 1 functionality associated with various signal processing functions. Layer 1, which includes a physical (PHY) layer, may include error detection on the transport channels, forward error correction (FEC) coding/decoding of the transport channels, interleaving, rate matching, mapping onto physical channels, modulation/demodulation of physical channels, and MIMO antenna processing. The TX processor 316 handles mapping to signal constellations based on various modulation schemes (e.g., binary phase-shift keying (BPSK), quadrature phase-shift keying (QPSK), M-phase-shift keying (M-PSK), M-quadrature amplitude modulation (M-QAM)). The coded and modulated symbols may then be split into parallel streams. Each stream may then be mapped to an OFDM subcarrier, multiplexed with a reference signal (e.g., pilot) in the time and/or frequency domain, and then combined together using an Inverse Fast Fourier Transform (IFFT) to produce a physical channel carrying a time domain OFDM symbol stream. The OFDM stream is spatially precoded to produce multiple spatial streams. Channel estimates from a channel estimator 374 may be used to determine the coding and modulation scheme, as well as for spatial processing. The channel estimate may be derived from a reference signal and/or channel condition feedback transmitted by the UE 350. Each spatial stream may then be provided to a different antenna 320 via a separate transmitter 318Tx. Each transmitter 318Tx may modulate a radio frequency (RF) carrier with a respective spatial stream for transmission.

- [0071] At the UE 350, each receiver 354Rx receives a signal through its respective antenna 352. Each receiver 354Rx recovers information modulated onto an RF carrier and provides the information to the receive (RX) processor 356. The TX processor 368 and the RX processor 356 implement layer 1 functionality associated with various signal processing functions. The RX processor 356 may perform spatial processing on the information to recover any spatial streams destined for the UE 350. If multiple spatial streams are destined for the UE 350, they may be combined by the RX processor 356 into a single OFDM symbol stream. The RX processor 356 then converts the OFDM symbol stream from the time-domain to the frequency domain using a Fast Fourier Transform (FFT). The frequency domain signal includes a separate OFDM symbol stream for each subcarrier of the OFDM signal. The symbols on each subcarrier, and the reference signal, are recovered and demodulated by determining the most likely signal constellation points transmitted by the base station 310. These soft decisions may be based on channel estimates computed by the channel estimator 358. The soft decisions are then decoded and deinterleaved to recover the data and control signals that were originally transmitted by the base station 310 on the physical channel. The data and control signals are then provided to the controller/processor 359, which implements layer 3 and layer 2 functionality.
- [0072] The controller/processor 359 can be associated with at least one memory 360 that stores program codes and data. The at least one memory 360 may be referred to as a computer-readable medium. In the UL, the controller/processor 359 provides demultiplexing between transport and logical channels, packet reassembly, deciphering, header decompression, and control signal processing to recover IP packets. The controller/processor 359 is also responsible for error detection using an ACK and/or NACK protocol to support HARQ operations.
- [0073] Similar to the functionality described in connection with the DL transmission by the base station 310, the controller/processor 359 provides RRC layer functionality associated with system information (e.g., MIB, SIBs) acquisition, RRC connections, and measurement reporting; PDCP layer functionality associated with header compression / decompression, and security (ciphering, deciphering, integrity protection, integrity verification); RLC layer functionality associated with the transfer of upper layer PDUs, error correction through ARQ, concatenation, segmentation, and reassembly of RLC SDUs, re-segmentation of RLC data PDUs, and reordering of

RLC data PDUs; and MAC layer functionality associated with mapping between logical channels and transport channels, multiplexing of MAC SDUs onto TBs, demultiplexing of MAC SDUs from TBs, scheduling information reporting, error correction through HARQ, priority handling, and logical channel prioritization.

- [0074] Channel estimates derived by a channel estimator 358 from a reference signal or feedback transmitted by the base station 310 may be used by the TX processor 368 to select the appropriate coding and modulation schemes, and to facilitate spatial processing. The spatial streams generated by the TX processor 368 may be provided to different antenna 352 via separate transmitters 354Tx. Each transmitter 354Tx may modulate an RF carrier with a respective spatial stream for transmission.
- [0075] The UL transmission is processed at the base station 310 in a manner similar to that described in connection with the receiver function at the UE 350. Each receiver 318Rx receives a signal through its respective antenna 320. Each receiver 318Rx recovers information modulated onto an RF carrier and provides the information to a RX processor 370.
- [0076] The controller/processor 375 can be associated with at least one memory 376 that stores program codes and data. The at least one memory 376 may be referred to as a computer-readable medium. In the UL, the controller/processor 375 provides demultiplexing between transport and logical channels, packet reassembly, deciphering, header decompression, control signal processing to recover IP packets. The controller/processor 375 is also responsible for error detection using an ACK and/or NACK protocol to support HARQ operations.
- [0077] At least one of the TX processor 368, the RX processor 356, and the controller/processor 359 may be configured to perform aspects in connection with the beam component 198 of FIG. 1.
- [0078] At least one of the TX processor 316, the RX processor 370, and the controller/processor 375 may be configured to perform aspects in connection with the beam component 199 of FIG. 1.
- [0079] The UE and the network may perform various aspects of beam management in order to select a beam for transmission and reception. In some aspects, beam management may be performed using a tracking reference signal (TRS), e.g., for a UE in an RRC inactive or RRC idle state. For initial access, a UE may use an SSB, e.g., with a wide beam sweeping procedure to identify a beam to use for initial access. For contention

based random access (CBRA), a UE may use a random access occasion (RO) and a preamble that corresponds to the selected SSB/beam. In an RRC connected state, the UE and/or network may perform various aspects of beam management, e.g., including a P1, P2, and P3 procedure using SSB or CSI-RS measurements; a U1, U2, and U3 procedure using SRS transmissions and measurement, L1-RSRP reporting. The network may configure one or more TCI state configurations for the UE, and may indicate a TCI state for the UE from the configured set of TCI states. In some aspects, the UE may provide L1-SINR reporting, which may reduce overhead and latency and allow for CC group beam updates or faster UL beam updates. In some aspects, the UE may communicate with the network using unified TCI states, L1/L2 centric mobility (which may also be referred to a L1/L2 triggered mobility (LTM), dynamic TCI updates, and/or uplink multi-panel selection, maximum permissible exposure (MPE) migration. Beam management may be employed for particular scenarios, such as high speed (e.g., high speed train (HST)), single frequency network (SNF), multiple transmission reception points (mTRP), among other examples. Based on measurements, a UE may identify a beam failure detection (BFD) and may perform a beam failure recovery (BFR). In some aspects, the BFD or BFR may be for a primary cell (PCell) or a primary secondary cell (PSCell). BFD may be based on a BFD reference signal (BFD-RS) and a PDCCH block error rate (BLER). The BFR may be based on a contention free random access (CFRA). For an SCell, the BFD and BFR may include a link recovery request via a scheduling request (SR), or a MAC-CE based BFR for the SCell. If the BFR is unsuccessful, the UE may identify a radio link failure.

[0080] Some wireless communication may include the use of AI or ML at the network and/or at the UE. Among various examples, AI/ML may be used for beam management at a UE and/or a network, including for performing beam predictions in a time domain and/or spatial domain. The use of an AI/ML model may reduce latency or overhead and may improve the accuracy of beam selection. Models may be provided that support various levels of network and UE collaboration and to support various use cases. The use of an AI/ML model may include various aspects such as model training, model deployment, model inference, model monitoring, and model updated.

[0081] FIG. 4A is an example of the AI/ML algorithm 400 of a method of wireless communication and illustrates various aspects model training, model inference, model

feedback, and model update. The AI/ML algorithm 400 may include various functions including a data collection 402, a model training function 404, a model inference function 406, and an actor 408.

- [0082]** The data collection 402 may be a function that provides input data to the model training function 404 and the model inference function 406. The data collection 402 function may include any form of data preparation, and it may not be specific to the implementation of the AI/ML algorithm (e.g., data pre-processing and cleaning, formatting, and transformation).
- [0083]** The examples of input data may include, but are not limited to, measurements, such as RSRP measurements or other TCI candidate information, channel measurements, positioning measurements, from entities including UEs or network nodes, feedback from the actor 408 (e.g., which may be a UE or network node), output from another AI/ML model. The data collection 402 may include training data, which refers to the data to be sent as the input for the AI/ML model training function 404, and inference data, which refers to be sent as the input for the AI/ML model inference function 406.
- [0084]** The model training function 404 may be a function that performs the ML model training, validation, and testing, which may generate model performance metrics as part of the model testing procedure. The model training function 404 may also be responsible for data preparation (e.g., data pre-processing and cleaning, formatting, and transformation) based on the training data delivered or received from the data collection 402 function. The model training function 404 may deploy or update a trained, validated, and tested AI/ML model to the model inference function 406, and receive a model performance feedback from the model inference function 406. As described above, there may be various functionalities to be performed by an AI/ML model for wireless communication.
- [0085]** The model inference function 406 may be a function that provides the AI/ML model inference output (e.g., predictions or decisions). The model inference function 406 may also perform data preparation (e.g., data pre-processing and cleaning, formatting, and transformation) based on the inference data delivered from the data collection 402 function. The output of the model inference function 406 may include the inference output of the AI/ML model produced by the model inference function 406. The details of the inference output may be use case specific. As an example, the output may include a beam prediction for beam management. The prediction may be for the

network or may be for the UE. In some aspects, the actor may be a component of the base station or of a core network. In other aspects, the actor may be a UE in communication with a wireless network.

[0086] The model performance feedback may refer to information derived from the model inference function 406 that may be suitable for the improvement of the AI/ML model trained in the model training function 404. The feedback from the actor 408 or other network entities (via the data collection 402 function) may be implemented for the model inference function 406 to create the model performance feedback.

[0087] The actor 408 may be a function that receives the output from the model inference function 406 and triggers or performs corresponding actions. The actor may trigger actions directed to network entities including the other network entities or itself. The actor 408 may also provide a feedback information that the model training function 404 or the model inference function 406 to derive training or inference data or performance feedback. The feedback may be transmitted back to the data collection 402.

[0088] The network or UE may use machine-learning algorithms, deep-learning algorithms, neural networks, reinforcement learning, regression, boosting, or advanced signal processing methods for aspects of wireless communication including the various functionalities such as beam management, CSF, or positioning, among other examples.

[0089] In some aspects described herein, the network or UE may train one or more neural networks to learn the dependence of measured qualities on individual parameters. Among others, examples of machine learning models or neural networks that may be included in the network entity include artificial neural networks (ANN); decision tree learning; convolutional neural networks (CNNs); deep learning architectures in which an output of a first layer of neurons becomes an input to a second layer of neurons, and so forth; support vector machines (SVM), e.g., including a separating hyperplane (e.g., decision boundary) that categorizes data; regression analysis; bayesian networks; genetic algorithms; Deep convolutional networks (DCNs) configured with additional pooling and normalization layers; and Deep belief networks (DBNs).

[0090] A machine learning model, such as an artificial neural network (ANN), may include an interconnected group of artificial neurons (e.g., neuron models), and may be a computational device or may represent a method to be performed by a computational

device. The connections of the neuron models may be modeled as weights. Machine learning models may provide predictive modeling, adaptive control, and other applications through training via a dataset. The model may be adaptive based on external or internal information that is processed by the machine learning model. Machine learning may provide non-linear statistical data model or decision making and may model complex relationships between input data and output information.

[0091] A machine learning model may include multiple layers and/or operations that may be formed by the concatenation of one or more of the referenced operations. Examples of operations that may be involved include extraction of various features of data, convolution operations, fully connected operations that may be activated or deactivated, compression, decompression, quantization, flattening, etc. As used herein, a “layer” of a machine learning model may be used to denote an operation on input data. For example, a convolution layer, a fully connected layer, and/or the like may be used to refer to associated operations on data that is input into a layer. A convolution AxB operation refers to an operation that converts a number of input features A into a number of output features B . “Kernel size” may refer to a number of adjacent coefficients that are combined in a dimension. As used herein, “weight” may be used to denote one or more coefficients used in the operations in the layers for combining various rows and/or columns of input data. For example, a fully connected layer operation may have an output y that is determined based at least in part on a sum of a product of input matrix x and weights A (which may be a matrix) and bias values B (which may be a matrix). The term “weights” may be used herein to generically refer to both weights and bias values. Weights and biases are examples of parameters of a trained machine learning model. Different layers of a machine learning model may be trained separately.

[0092] Machine learning models may include a variety of connectivity patterns, e.g., any feed-forward networks, hierarchical layers, recurrent architectures, feedback connections, etc. The connections between layers of a neural network may be fully connected or locally connected. In a fully connected network, a neuron in a first layer may communicate its output to each neuron in a second layer, and each neuron in the second layer may receive input from every neuron in the first layer. In a locally connected network, a neuron in a first layer may be connected to a limited number of neurons in the second layer. In some aspects, a convolutional network may be locally

connected and configured with shared connection strengths associated with the inputs for each neuron in the second layer. A locally connected layer of a network may be configured such that each neuron in a layer has the same, or similar, connectivity pattern, but with different connection strengths.

[0093] A machine learning model or neural network may be trained. For example, a machine learning model may be trained based on supervised learning. During training, the machine learning model may be presented with input that the model uses to compute to produce an output. The actual output may be compared to a target output, and the difference may be used to adjust parameters (such as weights and biases) of the machine learning model in order to provide an output closer to the target output. Before training, the output may be incorrect or less accurate, and an error, or difference, may be calculated between the actual output and the target output. The weights of the machine learning model may then be adjusted so that the output is more closely aligned with the target. To adjust the weights, a learning algorithm may compute a gradient vector for the weights. The gradient may indicate an amount that an error would increase or decrease if the weight were adjusted slightly. At the top layer, the gradient may correspond directly to the value of a weight connecting an activated neuron in the penultimate layer and a neuron in the output layer. In lower layers, the gradient may depend on the value of the weights and on the computed error gradients of the higher layers. The weights may then be adjusted so as to reduce the error or to move the output closer to the target. This manner of adjusting the weights may be referred to as back propagation through the neural network. The process may continue until an achievable error rate stops decreasing or until the error rate has reached a target level.

[0094] The machine learning models may include computational complexity and substantial processor for training the machine learning model. An output of one node is connected as the input to another node. Connections between nodes may be referred to as edges, and weights may be applied to the connections/edges to adjust the output from one node that is applied as input to another node. Nodes may apply thresholds in order to determine whether, or when, to provide output to a connected node. The output of each node may be calculated as a non-linear function of a sum of the inputs to the node. The neural network may include any number of nodes and any type of connections between nodes. The neural network may include one or more hidden

nodes. Nodes may be aggregated into layers, and different layers of the neural network may perform different kinds of transformations on the input. A signal may travel from input at a first layer through the multiple layers of the neural network to output at the last layer of the neural network and may traverse layers multiple times.

[0095] In some aspects, for example with reference to diagram 410 of FIG. 4B, the AI/ML model may be utilized for spatial beam prediction. For example, a first set of beams (e.g., Set B) may be a set of beams whose measurements are taken as inputs of the AI/ML model. A second set of beams (e.g., Set A) may be a set of beams from which the AI/ML model performs predictions (at the output of AI/ML model). In spatial domain beam prediction, the beams of Set B may be comprised of wide beams and the beams of Set A may be comprised of narrow beams. In some aspects, the beams of Set B may be a subset of the beams of Set A. In some aspects, such as temporal beam predictions, as shown in diagram 500 of FIG. 5, Set B may be a subset of Set A, Set B may not be a subset of Set A, or Set A and Set B are the same.

[0096] Assistance information from the network to the UE for a UE-side AI/ML model may provide assistance for beam predictions. For example, the assistance information may include network side beam shape information (e.g., 3dB beamwidth, beam boresight directions, beam shape, transmission beam angle, etc.). In UE-side AI/ML models, layer 1 (L1) reference signal receive power (RSRP) may be enhanced. For example, a UE-side AI/ML model for beam predictions may comprise L1 signaling to report information of the AI/ML model inference to the network, such as but not limited to, beams that are based on the output of the AI/ML model inference, beams of future time instances that are based on an output of the AI/ML model inference, or information about timing corresponding to reported beams. Beam prediction by the UE may have reduced or sub-optimal performance in the absence of assistance information related to downlink transmission beams of the network entity.

[0097] Aspects presented herein provide a configuration for beam-related assistance information for UE side modeling. For example, a UE may receive assistance information from a network entity that indicates an association between one or more grid indices and one or more transmission beams from the network entity to predict a set of beams based on a beam prediction procedure. At least one advantage of the disclosure is that UEs may improve beam prediction by utilizing assistance information from the network.

[0098] FIG. 6 provides a diagram 600 of an example of a wide to narrow beam prediction. In the diagram 600 of FIG. 6 Case 1 and Case 2 may be comprised of three wide beams and eight narrow beams. Case 1 and Case 2, as shown in FIG. 6, may be distinct in that the learned mapping from Set B (set of wide beams) to Set A (set of narrow beams) is quite different for the two cases. For example, in instances where a UE receives assistance information including beam-related information, then during the data collection phase the UE may log the training data associated with each case separately. The UE may choose to train a separate model per each case. During the inference phase, if UE is aware of the deployed case (e.g., through indication of assistance information from the network), then the UE may use the appropriate model trained for the particular case accordingly. In the absence of any beam-related assistance information, the UE may have difficulty in differentiating Case 1 from Case 2. During data collection, the UE may not be able to tag the collected data from two cases differently, and the UE-side model may not be able to generalize well to both cases. FIG. 7 provides a diagram 700 of an example where Set B is a subset of Set A. The description of FIG. 6 is applicable to the diagram 700 of FIG. 7.

[0099] FIG. 8 provides a diagram 800 of assistance information from the network to a UE. In some aspects, at the base station side, the angular space may be divided into a two-dimensional grid. For example, a global coordinate system may be utilized to define or divide the angular space into the two-dimensional grid. The two-dimensional grid may correspond with a grid index. In some instances, the granularity of the grid may be the same or different for SSB or CSI-RS beams. Each area of the two-dimensional grid may be indexed, such that multiple grids may be preconfigured based on predefined rules. In some aspects, the network may configure the two-dimensional grid. The UE may be configured to utilize one or more grid identifiers (IDs) in association with the two-dimensional grid as opposed to using beam IDs, which may allow for the grid IDs to be consistent across training and inference. In some aspects, the beam IDs may be mapped to grid IDs based on a one-to-one relationship or on a many-to-one relationship based on the granularity of the two-dimensional grid.

[0100] In instances of a predefined two-dimensional grid, the association of beam IDs to grid IDs may not change dynamically, and may be signaled statically or semi-statically from the network to the UE. For example, the association of beam IDs to grid IDs may be signaled via RRC, or the like. The UE may use the grid IDs as labels while

training UE-side AI/ML models (instead of beam IDs), particularly if the grid has sufficient granularity. The UE may include a predicted best grid ID(s) instead of predicted best beam indices in instances where the enhanced L1-RSRP report includes UE-side predictions of network-side beams (e.g., downlink transmission beams). In response to reception of the report from the UE, the network may sweep over beams within the predicted grid ID(s) signaled by the UE to find the best downlink transmission beam(s) within those predicted grid IDs. Reliance alone on beam indices may not be sufficient as the beam indexing may change across training and inference. However, the grid index may be associated with a physical direction and may be consistent across training and inference.

[0101] FIG. 9 provides a diagram 900 of an example of a two-dimensional grid. Diagram 900 of FIG. 9 illustrates an example of beam point angles, in azimuth and elevation, in conjunction with the two-dimensional grid. In the example of FIG. 9, the two-dimensional grid comprises a one-to-one mapping from beam pointing angles to the grid areas.

[0102] FIG. 10 provides a diagram 1000 of an example of a two-dimensional grid. Diagram 1000 of FIG. 10 illustrates an example of beam point angles, in azimuth and elevation, in conjunction with the two-dimensional grid, similarly as in FIG. 9. However, in the example of FIG. 10, the two-dimensional grid has a grid index having a different granularity than that of FIG. 9. For example, the grid index of the example of FIG. 10 may have a granularity that is coarser in comparison to the grid index of the example of FIG. 9. In the example of FIG. 10, two beams may be associated with a single grid ID.

[0103] FIG. 11 provides a diagram 1100 of an example of a two-dimensional grid. Diagram 1100 of FIG. 11 illustrates an example of beam point angles, in azimuth and elevation, in conjunction with the two-dimensional grid, similarly as in FIGs. 9 and 10. However, in the example of FIG. 11, the two-dimensional grid has a grid index having a different granularity than that of FIGs. 9 or 10. For example, the grid index of the example of FIG. 11 may have a granularity that is very coarse or coarser in comparison to the grid index of the examples of FIGs. 9 or 10. In the example of FIG. 11, eight beams may be associated with a single grid ID. The disclosure is not intended to be limited to the aspects disclosed herein. In some aspects, one or more beams may be associated with a single grid ID, and the disclosure is not intended to

be limited to one, two, or eight. In some aspects, each of the grid IDs may be associated with the same amount of beams or a different amount of beams.

[0104] FIG. 12 is a call flow diagram 1200 of signaling between a UE 1202 and a base station 1204. The base station 1204 may be configured to provide at least one cell. The UE 1202 may be configured to communicate with the base station 1204. For example, in the context of FIG. 1, the base station 1204 may correspond to base station 102 and the UE 1202 may correspond to at least UE 104. In another example, in the context of FIG. 3, the base station 1204 may correspond to base station 310 and the UE 1202 may correspond to UE 350.

[0105] At 1206, the base station 1204 may provide, to the UE 1202, assistance information indicating an association between one or more grid indices and one or more transmission beams of the base station 1204. The UE 1202 may receive the assistance information indicating the association between the one or more grid indices and the one or more transmission beams of the base station 1204. In some aspects, the one or more grid indices may indicate a grid location within an azimuth and elevation grid. In some aspects, the one or more grid indices may be associated with a two-dimensional grid, with each grid index corresponding to a portion of the two-dimensional grid that comprises beam pointing angles of the one or more transmission beams of the base station.

[0106] At 1208, the UE 1202 may measure at least one downlink signal from the base station 1204 using a first set of beams. The UE may measure the at least one downlink signal from the base station using the first set of beams to make a prediction for a second set of beams based on a beam prediction procedure. In some aspects, the second set of beams may be generated or determined, by the UE 1202, based on the assistance information. In some aspects, the beam information may comprise information related to the second set of beams. In some aspects, the beam information may comprise beam-related information associated with the beam prediction procedure. The beam-related information may correspond to one or more beams from the second set of beams that are associated with the one or more grid indices and the one or more transmission beams of the base station.

[0107] At 1210, the UE 1202 may transmit beam information based on measurement of at least one downlink signal from the base station and the assistance information. The base station 1204 may obtain, from the UE 1202, the beam information based on the

measurement of the at least one downlink signal and the assistance information. In some aspects, the beam information may be based on a predicted measurement for the one or more grid indices using an artificial intelligence or machine learning model. In some aspects, the beam information may comprise one or more beam IDs that correspond to the one or more transmission beams of the base station. In some aspects, the beam information may include a beam prediction based on the measurement of the at least one downlink signal from the base station on a first set of beams to predict a predicted measurement for a second set of beams based on a mapping to the one or more grid indices. The mapping of the second set of beams with the one or more grid indices may be based on one or more grid IDs associated with a corresponding grid index of the one or more grid indices.

[0108] At 1212, the base station 1204 may provide an indication comprising a subset of beams of the one or more transmission beams of the base station. The UE 1202 may receive, from the base station 1204, the indication comprising the subset of beams of the one or more transmission beams of the base station. The UE may receive the indication comprising the subset of beams of the one or more transmission beams in response to transmission of the beam information.

[0109] At 1214, the UE 1202 may transmit a measurement report of the subset of beams of the one or more transmission beams of the base station. The base station 1204 may obtain the measurement report from the UE 1202.

[0110] FIG. 13 is a flowchart 1300 of a method of wireless communication. The method may be performed by a UE (e.g., the UE 104; the apparatus 1504). One or more of the illustrated operations may be omitted, transposed, or contemporaneous. The method may allow a UE to perform a beam prediction procedure based on assistance information from the network.

[0111] At 1302, the UE may receive assistance information indicating an association between one or more grid indices and one or more transmission beams of a network entity. For example, 1302 may be performed by beam component 198 of apparatus 1504. The UE may receive the assistance information from the network entity. In some aspects, the one or more grid indices may indicate a grid location within an azimuth and elevation grid. In some aspects, the one or more grid indices may be associated with a two-dimensional grid, with each grid index corresponding to a portion of the two-

dimensional grid that comprises beam pointing angles of the one or more transmission beams of the network entity.

[0112] At 1304, the UE may transmit beam information based on measurement of at least one downlink signal from the network entity and the assistance information. For example, 1304 may be performed by beam component 198 of apparatus 1504. The UE may transmit the beam information to the network entity. In some aspects, the beam information may be based on a predicted measurement for the one or more grid indices using an artificial intelligence or machine learning model. In some aspects, the beam information may comprise one or more beam identifiers (IDs) that correspond to the one or more transmission beams of the network entity. In some aspects, the beam information may include a beam prediction based on the measurement of the at least one downlink signal from the network entity on a first set of beams to predict a predicted measurement for a second set of beams based on a mapping to the one or more grid indices. The mapping of the second set of beams with the one or more grid indices may be based on one or more grid IDs associated with a corresponding grid index of the one or more grid indices.

[0113] FIG. 14 is a flowchart 1400 of a method of wireless communication. The method may be performed by a UE (e.g., the UE 104; the apparatus 1504). One or more of the illustrated operations may be omitted, transposed, or contemporaneous. The method may allow a UE to perform a beam prediction procedure based on assistance information from the network.

[0114] At 1402, the UE may receive assistance information indicating an association between one or more grid indices and one or more transmission beams of a network entity. For example, 1402 may be performed by beam component 198 of apparatus 1504. The UE may receive the assistance information from the network entity. In some aspects, the one or more grid indices may indicate a grid location within an azimuth and elevation grid. In some aspects, the one or more grid indices may be associated with a two-dimensional grid, with each grid index corresponding to a portion of the two-dimensional grid that comprises beam pointing angles of the one or more transmission beams of the network entity.

[0115] At 1404, the UE may measure at least one downlink signal from the network entity using a first set of beams to make a prediction for a second set of beams based on a beam prediction procedure. For example, 1404 may be performed by beam

component 198 of apparatus 1504. In some aspects, the second set of beams may be generated based on the assistance information. In some aspects, the beam information may comprise information related to the second set of beams. In some aspects, the beam information may comprise beam-related information associated with the beam prediction procedure. The beam-related information may correspond to one or more beams from the second set of beams that are associated with the one or more grid indices and the one or more transmission beams of the network entity.

[0116] At 1406, the UE may transmit beam information based on measurement of at least one downlink signal from the network entity and the assistance information. For example, 1406 may be performed by beam component 198 of apparatus 1504. The UE may transmit the beam information to the network entity. In some aspects, the beam information may be based on a predicted measurement for the one or more grid indices using an artificial intelligence or machine learning model. In some aspects, the beam information may comprise one or more beam IDs that correspond to the one or more transmission beams of the network entity. In some aspects, the beam information may include a beam prediction based on the measurement of the at least one downlink signal from the network entity on a first set of beams to predict a predicted measurement for a second set of beams based on a mapping to the one or more grid indices. The mapping of the second set of beams with the one or more grid indices may be based on one or more grid IDs associated with a corresponding grid index of the one or more grid indices.

[0117] At 1408, the UE may receive an indication comprising a subset of beams of the one or more transmission beams of the network entity. For example, 1408 may be performed by beam component 198 of apparatus 1504. The UE may receive the indication comprising the subset of beams of the one or more transmission beams from the network entity. The UE may receive the indication comprising the subset of beams of the one or more transmission beams in response to transmission of the beam information.

[0118] At 1410, the UE may transmit a measurement report of the subset of beams of the one or more transmission beams of the network entity. For example, 1410 may be performed by beam component 198 of apparatus 1504. The UE may transmit the measurement report of the subset of beams of the one or more transmission beams to the network entity.

[0119] FIG. 15 is a diagram 1500 illustrating an example of a hardware implementation for an apparatus 1504. The apparatus 1504 may be a UE, a component of a UE, or may implement UE functionality. In some aspects, the apparatus 1504 may include at least one cellular baseband processor 1524 (also referred to as a modem) coupled to one or more transceivers 1522 (e.g., cellular RF transceiver). The cellular baseband processor(s) 1524 may include at least one on-chip memory 1524'. In some aspects, the apparatus 1504 may further include one or more subscriber identity modules (SIM) cards 1520 and at least one application processor 1506 coupled to a secure digital (SD) card 1508 and a screen 1510. The application processor(s) 1506 may include on-chip memory 1506'. In some aspects, the apparatus 1504 may further include a Bluetooth module 1512, a WLAN module 1514, an SPS module 1516 (e.g., GNSS module), one or more sensor modules 1518 (e.g., barometric pressure sensor / altimeter; motion sensor such as inertial measurement unit (IMU), gyroscope, and/or accelerometer(s); light detection and ranging (LIDAR), radio assisted detection and ranging (RADAR), sound navigation and ranging (SONAR), magnetometer, audio and/or other technologies used for positioning), additional memory modules 1526, a power supply 1530, and/or a camera 1532. The Bluetooth module 1512, the WLAN module 1514, and the SPS module 1516 may include an on-chip transceiver (TRX) (or in some cases, just a receiver (RX)). The Bluetooth module 1512, the WLAN module 1514, and the SPS module 1516 may include their own dedicated antennas and/or utilize the antennas 1580 for communication. The cellular baseband processor(s) 1524 communicates through the transceiver(s) 1522 via one or more antennas 1580 with the UE 104 and/or with an RU associated with a network entity 1502. The cellular baseband processor(s) 1524 and the application processor(s) 1506 may each include a computer-readable medium / memory 1524', 1506', respectively. The additional memory modules 1526 may also be considered a computer-readable medium / memory. Each computer-readable medium / memory 1524', 1506', 1526 may be non-transitory. The cellular baseband processor(s) 1524 and the application processor(s) 1506 are each responsible for general processing, including the execution of software stored on the computer-readable medium / memory. The software, when executed by the cellular baseband processor(s) 1524 / application processor(s) 1506, causes the cellular baseband processor(s) 1524 / application processor(s) 1506 to perform the various functions described *supra*. The cellular baseband processor(s)

1524 and the application processor(s) 1506 are configured to perform the various functions described *supra* based at least in part of the information stored in the memory. That is, the cellular baseband processor(s) 1524 and the application processor(s) 1506 may be configured to perform a first subset of the various functions described *supra* without information stored in the memory and may be configured to perform a second subset of the various functions described *supra* based on the information stored in the memory. The computer-readable medium / memory may also be used for storing data that is manipulated by the cellular baseband processor(s) 1524 / application processor(s) 1506 when executing software. The cellular baseband processor(s) 1524 / application processor(s) 1506 may be a component of the UE 350 and may include the at least one memory 360 and/or at least one of the TX processor 368, the RX processor 356, and the controller/processor 359. In one configuration, the apparatus 1504 may be at least one processor chip (modem and/or application) and include just the cellular baseband processor(s) 1524 and/or the application processor(s) 1506, and in another configuration, the apparatus 1504 may be the entire UE (e.g., see UE 350 of FIG. 3) and include the additional modules of the apparatus 1504.

[0120] As discussed *supra*, the component 198 may be configured to receive, from a network entity, assistance information indicating an association between one or more grid indices and one or more transmission beams of the network entity; and transmit, to the network entity, beam information based on measurement of at least one downlink signal from the network entity and the assistance information. The component 198 may be within the cellular baseband processor(s) 1524, the application processor(s) 1506, or both the cellular baseband processor(s) 1524 and the application processor(s) 1506. The component 198 may be one or more hardware components specifically configured to carry out the stated processes/algorithm, implemented by one or more processors configured to perform the stated processes/algorithm, stored within a computer-readable medium for implementation by one or more processors, or some combination thereof. When multiple processors are implemented, the multiple processors may perform the stated processes/algorithm individually or in combination. As shown, the apparatus 1504 may include a variety of components configured for various functions. In one configuration, the apparatus 1504, and in particular the cellular baseband processor(s) 1524 and/or the application processor(s)

1506, may include means for receiving, from a network entity, assistance information indicating an association between one or more grid indices and one or more transmission beams of the network entity. The apparatus includes means for transmitting, to the network entity, beam information based on measurement of at least one downlink signal from the network entity and the assistance information. The apparatus further includes means for measuring at least one downlink signal from the network entity using a first set of beams to make a prediction for a second set of beams based on a beam prediction procedure. The apparatus further includes means for receiving, from the network entity, an indication comprising a subset of beams of the one or more transmission beams in response to transmission of the beam information. The apparatus further includes means for transmitting, to the network entity, a measurement report of the subset of beams of the one or more transmission beams. The means may be the component 198 of the apparatus 1504 configured to perform the functions recited by the means. As described *supra*, the apparatus 1504 may include the TX processor 368, the RX processor 356, and the controller/processor 359. As such, in one configuration, the means may be the TX processor 368, the RX processor 356, and/or the controller/processor 359 configured to perform the functions recited by the means.

[0121] FIG. 16 is a flowchart 1600 of a method of wireless communication. The method may be performed by a base station (e.g., the base station 102; the network entity 1502, 1802). One or more of the illustrated operations may be omitted, transposed, or contemporaneous. The method may allow a UE to perform a beam prediction procedure based on assistance information from the network.

[0122] At 1602, the network entity may provide assistance information indicating an association between one or more grid indices and one or more transmission beams of the network entity. For example, 1602 may be performed by beam component 199 of network entity 1802. The network entity may provide the assistance information to a UE. In some aspects, the one or more grid indices may indicate a grid location within an azimuth and elevation grid. In some aspects, the one or more grid indices may be associated with a two-dimensional grid. Each grid index may correspond to a portion of the two-dimensional grid that comprises beam pointing angles of the one or more transmission beams of the network entity.

[0123] At 1604, the network entity may obtain beam information based on measurement of at least one downlink signal from the network entity and the assistance information. For example, 1604 may be performed by beam component 199 of network entity 1802. The network entity may obtain the beam information from the UE. In some aspects, the beam information may be based on a predicted measurement for the one or more grid indices using an artificial intelligence or machine learning model. In some aspects, the beam information may comprise one or more beam IDs that may correspond to the one or more transmission beams of the network entity. In some aspects, the beam information may include a beam prediction based on the measurement of the at least one downlink signal from the network entity on a first set of beams to predict a predicted measurement for a second set of beams based on a mapping to the one or more grid indices. The mapping of the second set of beams with the one or more grid indices may be based on one or more grid IDs associated with a corresponding grid index of the one or more grid indices. In some aspects, the beam information may comprise information related to a beam prediction procedure. The at least one downlink signal from the network entity may be measured by the UE based on a first set of beams to make a prediction for a second set of beams based on the beam prediction procedure. The second set of beams may be generated based on the assistance information. In some aspects, the beam information may comprise beam-related information associated with the beam prediction procedure. The beam-related information may correspond to one or more beams from the second set of beams that are associated with the one or more grid indices and the one or more transmission beams of the network entity.

[0124] FIG. 17 is a flowchart 1700 of a method of wireless communication. The method may be performed by a base station (e.g., the base station 102; the network entity 1502, 1802). One or more of the illustrated operations may be omitted, transposed, or contemporaneous. The method may allow a UE to perform a beam prediction procedure based on assistance information from the network.

[0125] At 1702, the network entity may provide assistance information indicating an association between one or more grid indices and one or more transmission beams of the network entity. For example, 1702 may be performed by beam component 199 of network entity 1802. The network entity may provide the assistance information to a UE. In some aspects, the one or more grid indices may indicate a grid location within

an azimuth and elevation grid. In some aspects, the one or more grid indices may be associated with a two-dimensional grid. Each grid index may correspond to a portion of the two-dimensional grid that comprises beam pointing angles of the one or more transmission beams of the network entity.

[0126] At 1704, the network entity may obtain beam information based on measurement of at least one downlink signal from the network entity and the assistance information. For example, 1704 may be performed by beam component 199 of network entity 1802. The network entity may obtain the beam information from the UE. In some aspects, the beam information may be based on a predicted measurement for the one or more grid indices using an artificial intelligence or machine learning model. In some aspects, the beam information may comprise one or more beam IDs that may correspond to the one or more transmission beams of the network entity. In some aspects, the beam information may include a beam prediction based on the measurement of the at least one downlink signal from the network entity on a first set of beams to predict a predicted measurement for a second set of beams based on a mapping to the one or more grid indices. The mapping of the second set of beams with the one or more grid indices may be based on one or more grid IDs associated with a corresponding grid index of the one or more grid indices. In some aspects, the beam information may comprise information related to a beam prediction procedure. The at least one downlink signal from the network entity may be measured by the UE based on a first set of beams to make a prediction for a second set of beams based on the beam prediction procedure. The second set of beams may be generated based on the assistance information. In some aspects, the beam information may comprise beam-related information associated with the beam prediction procedure. The beam-related information may correspond to one or more beams from the second set of beams that are associated with the one or more grid indices and the one or more transmission beams of the network entity.

[0127] At 1706, the network entity may provide an indication comprising a subset of beams of the one or more transmission beams of the network entity. For example, 1706 may be performed by beam component 199 of network entity 1802. The network entity may provide the indication comprising the subset of beams of the one or more transmission beams to the UE. The network entity may provide the indication

comprising the subset of beams of the one or more transmission beams in response to the beam information.

[0128] At 1708, the network entity may obtain a measurement report of the subset of beams of the one or more transmission beam of the network entity. For example, 1708 may be performed by beam component 199 of network entity 1802. The network entity may obtain the measurement report of the subset of beams of the one or more transmission beam from the UE.

[0129] FIG. 18 is a diagram 1800 illustrating an example of a hardware implementation for a network entity 1802. The network entity 1802 may be a BS, a component of a BS, or may implement BS functionality. The network entity 1802 may include at least one of a CU 1810, a DU 1830, or an RU 1840. For example, depending on the layer functionality handled by the component 199, the network entity 1802 may include the CU 1810; both the CU 1810 and the DU 1830; each of the CU 1810, the DU 1830, and the RU 1840; the DU 1830; both the DU 1830 and the RU 1840; or the RU 1840. The CU 1810 may include at least one CU processor 1812. The CU processor(s) 1812 may include on-chip memory 1812'. In some aspects, the CU 1810 may further include additional memory modules 1814 and a communications interface 1818. The CU 1810 communicates with the DU 1830 through a midhaul link, such as an F1 interface. The DU 1830 may include at least one DU processor 1832. The DU processor(s) 1832 may include on-chip memory 1832'. In some aspects, the DU 1830 may further include additional memory modules 1834 and a communications interface 1838. The DU 1830 communicates with the RU 1840 through a fronthaul link. The RU 1840 may include at least one RU processor 1842. The RU processor(s) 1842 may include on-chip memory 1842'. In some aspects, the RU 1840 may further include additional memory modules 1844, one or more transceivers 1846, antennas 1880, and a communications interface 1848. The RU 1840 communicates with the UE 104. The on-chip memory 1812', 1832', 1842' and the additional memory modules 1814, 1834, 1844 may each be considered a computer-readable medium / memory. Each computer-readable medium / memory may be non-transitory. Each of the processors 1812, 1832, 1842 is responsible for general processing, including the execution of software stored on the computer-readable medium / memory. The software, when executed by the corresponding processor(s) causes the processor(s) to perform the various functions described *supra*. The computer-readable medium /

memory may also be used for storing data that is manipulated by the processor(s) when executing software.

[0130] As discussed *supra*, the component 199 may be configured to provide, to a UE, assistance information indicating an association between one or more grid indices and one or more transmission beams of the network entity; and obtain, from the UE, beam information based on measurement of at least one downlink signal from the network entity and the assistance information. The component 199 may be within one or more processors of one or more of the CU 1810, DU 1830, and the RU 1840. The component 199 may be one or more hardware components specifically configured to carry out the stated processes/algorithm, implemented by one or more processors configured to perform the stated processes/algorithm, stored within a computer-readable medium for implementation by one or more processors, or some combination thereof. When multiple processors are implemented, the multiple processors may perform the stated processes/algorithm individually or in combination. The network entity 1802 may include a variety of components configured for various functions. In one configuration, the network entity 1802 may include means for providing, to a UE, assistance information indicating an association between one or more grid indices and one or more transmission beams of the network entity. The network entity includes means for obtaining, from the UE, beam information based on measurement of at least one downlink signal from the network entity and the assistance information. The network entity further includes means for providing, to the UE, an indication comprising a subset of beams of the one or more transmission beams in response to the beam information. The network entity further includes means for obtaining, from the UE, a measurement report of the subset of beams of the one or more transmission beams. The means may be the component 199 of the network entity 1802 configured to perform the functions recited by the means. As described *supra*, the network entity 1802 may include the TX processor 316, the RX processor 370, and the controller/processor 375. As such, in one configuration, the means may be the TX processor 316, the RX processor 370, and/or the controller/processor 375 configured to perform the functions recited by the means.

[0131] It is understood that the specific order or hierarchy of blocks in the processes / flowcharts disclosed is an illustration of example approaches. Based upon design preferences, it is understood that the specific order or hierarchy of blocks in the

processes / flowcharts may be rearranged. Further, some blocks may be combined or omitted. The accompanying method claims present elements of the various blocks in a sample order, and are not limited to the specific order or hierarchy presented.

[0132] The previous description is provided to enable any person skilled in the art to practice the various aspects described herein. Various modifications to these aspects will be readily apparent to those skilled in the art, and the generic principles defined herein may be applied to other aspects. Thus, the claims are not limited to the aspects described herein, but are to be accorded the full scope consistent with the language claims. Reference to an element in the singular does not mean “one and only one” unless specifically so stated, but rather “one or more.” Terms such as “if,” “when,” and “while” do not imply an immediate temporal relationship or reaction. That is, these phrases, e.g., “when,” do not imply an immediate action in response to or during the occurrence of an action, but simply imply that if a condition is met then an action will occur, but without requiring a specific or immediate time constraint for the action to occur. The word “exemplary” is used herein to mean “serving as an example, instance, or illustration.” Any aspect described herein as “exemplary” is not necessarily to be construed as preferred or advantageous over other aspects. Unless specifically stated otherwise, the term “some” refers to one or more. Combinations such as “at least one of A, B, or C,” “one or more of A, B, or C,” “at least one of A, B, and C,” “one or more of A, B, and C,” and “A, B, C, or any combination thereof” include any combination of A, B, and/or C, and may include multiples of A, multiples of B, or multiples of C. Specifically, combinations such as “at least one of A, B, or C,” “one or more of A, B, or C,” “at least one of A, B, and C,” “one or more of A, B, and C,” and “A, B, C, or any combination thereof” may be A only, B only, C only, A and B, A and C, B and C, or A and B and C, where any such combinations may contain one or more member or members of A, B, or C. Sets should be interpreted as a set of elements where the elements number one or more. Accordingly, for a set of X, X would include one or more elements. When at least one processor is configured to perform a set of functions, the at least one processor, individually or in any combination, is configured to perform the set of functions. Accordingly, each processor of the at least one processor may be configured to perform a particular subset of the set of functions, where the subset is the full set, a proper subset of the set, or an empty subset of the set. If a first apparatus receives data from or transmits

data to a second apparatus, the data may be received/transmitted directly between the first and second apparatuses, or indirectly between the first and second apparatuses through a set of apparatuses. A device configured to “output” data, such as a transmission, signal, or message, may transmit the data, for example with a transceiver, or may send the data to a device that transmits the data. A device configured to “obtain” data, such as a transmission, signal, or message, may receive, for example with a transceiver, or may obtain the data from a device that receives the data. Information stored in a memory includes instructions and/or data. All structural and functional equivalents to the elements of the various aspects described throughout this disclosure that are known or later come to be known to those of ordinary skill in the art are expressly incorporated herein by reference and are encompassed by the claims. Moreover, nothing disclosed herein is dedicated to the public regardless of whether such disclosure is explicitly recited in the claims. The words “module,” “mechanism,” “element,” “device,” and the like may not be a substitute for the word “means.” As such, no claim element is to be construed as a means plus function unless the element is expressly recited using the phrase “means for.”

- [0133]** As used herein, the phrase “based on” shall not be construed as a reference to a closed set of information, one or more conditions, one or more factors, or the like. In other words, the phrase “based on A” (where “A” may be information, a condition, a factor, or the like) shall be construed as “based at least on A” unless specifically recited differently.
- [0134]** The following aspects are illustrative only and may be combined with other aspects or teachings described herein, without limitation.
- [0135]** Aspect 1 is a method of wireless communication at a UE comprising receiving, from a network entity, assistance information indicating an association between one or more grid indices and one or more transmission beams of the network entity; and transmitting, to the network entity, beam information based on measurement of at least one downlink signal from the network entity and the assistance information.
- [0136]** Aspect 2 is the method of aspect 1, further includes that the beam information is based on a predicted measurement for the one or more grid indices using an artificial intelligence or machine learning model.

- [0137] Aspect 3 is the method of any of aspects 1 and 2, further includes that the beam information comprises one or more beam IDs that correspond to the one or more transmission beams of the network entity.
- [0138] Aspect 4 is the method of any of aspects 1-3, further includes that the one or more grid indices indicate a grid location within an azimuth and elevation grid.
- [0139] Aspect 5 is the method of any of aspects 1-4, further includes that the one or more grid indices are associated with a two-dimensional grid, with each grid index corresponding to a portion of the two-dimensional grid that comprises beam pointing angles of the one or more transmission beams of the network entity.
- [0140] Aspect 6 is the method of any of aspects 1-5, further includes that the beam information includes a beam prediction based on the measurement of the at least one downlink signal from the network entity on a first set of beams to predict a predicted measurement for a second set of beams based on a mapping to the one or more grid indices.
- [0141] Aspect 7 is the method of any of aspects 1-6, further includes that the mapping of the second set of beams with the one or more grid indices is based on one or more grid IDs associated with a corresponding grid index of the one or more grid indices.
- [0142] Aspect 8 is the method of any of aspects 1-7, further including measuring at least one downlink signal from the network entity using a first set of beams to make a prediction for a second set of beams based on a beam prediction procedure.
- [0143] Aspect 9 is the method of any of aspects 1-8, further includes that the second set of beams is generated based on the assistance information.
- [0144] Aspect 10 is the method of any of aspects 1-9, further includes that the beam information comprises information related to the second set of beams.
- [0145] Aspect 11 is the method of any of aspects 1-10, further includes that the beam information comprises beam-related information associated with the beam prediction procedure, wherein the beam-related information corresponds to one or more beams from the second set of beams that are associated with at the one or more grid indices and the one or more transmission beams of the network entity.
- [0146] Aspect 12 is the method of any of aspects 1-11, further including receiving, from the network entity, an indication comprising a subset of beams of the one or more transmission beams in response to transmission of the beam information; and

transmitting, to the network entity, a measurement report of the subset of beams of the one or more transmission beams.

- [0147] Aspect 13 is an apparatus for wireless communication at a UE including at least one processor coupled to a memory and at least one transceiver, the at least one processor configured to implement any of Aspects 1-12.
- [0148] Aspect 14 is an apparatus for wireless communication at a UE including means for implementing any of Aspects 1-12.
- [0149] Aspect 15 is a computer-readable medium storing computer executable code, where the code when executed by a processor causes the processor to implement any of Aspects 1-12.
- [0150] Aspect 16 is a method of wireless communication at a network entity comprising providing, to a UE, assistance information indicating an association between one or more grid indices and one or more transmission beams of the network entity; and obtaining, from the UE, beam information based on measurement of at least one downlink signal from the network entity and the assistance information.
- [0151] Aspect 17 is the method of aspect 16, further includes that the beam information is based on a predicted measurement for the one or more grid indices using an artificial intelligence or machine learning model.
- [0152] Aspect 18 is the method of any of aspects 16 and 17, further includes that the beam information comprises one or more beam IDs that correspond to the one or more transmission beams of the network entity.
- [0153] Aspect 19 is the method of any of aspects 16-18, further includes that the one or more grid indices indicate a grid location within an azimuth and elevation grid.
- [0154] Aspect 20 is the method of any of aspects 16-19, further includes that the one or more grid indices are associated with a two-dimensional grid, with each grid index corresponding to a portion of the two-dimensional grid that comprises beam pointing angles of the one or more transmission beams of the network entity.
- [0155] Aspect 21 is the method of any of aspects 16-20, further includes that the beam information includes a beam prediction based on the measurement of the at least one downlink signal from the network entity on a first set of beams to predict a predicted measurement for a second set of beams based on a mapping to the one or more grid indices.

- [0156] Aspect 22 is the method of any of aspects 16-21, further includes that the mapping of the second set of beams with the one or more grid indices is based on one or more grid IDs associated with a corresponding grid index of the one or more grid indices.
- [0157] Aspect 23 is the method of any of aspects 16-22, further includes that the beam information comprises information related to a beam prediction procedure, wherein the at least one downlink signal from the network entity are measured by the UE based on a first set of beams to make a prediction for a second set of beams based on the beam prediction procedure.
- [0158] Aspect 24 is the method of any of aspects 16-23, further includes that the second set of beams is generated based on the assistance information.
- [0159] Aspect 25 is the method of any of aspects 16-24, further includes that the beam information comprises beam-related information associated with the beam prediction procedure, wherein the beam-related information corresponds to one or more beams from the second set of beams that are associated with at the one or more grid indices and the one or more transmission beams of the network entity.
- [0160] Aspect 26 is the method of any of aspects 16-25, further including providing, to the UE, an indication comprising a subset of beams of the one or more transmission beams in response to the beam information; and obtaining, from the UE, a measurement report of the subset of beams of the one or more transmission beams.
- [0161] Aspect 27 is an apparatus for wireless communication at a UE including at least one processor coupled to a memory and at least one transceiver, the at least one processor configured to implement any of Aspects 16-26.
- [0162] Aspect 28 is an apparatus for wireless communication at a UE including means for implementing any of Aspects 16-26.
- [0163] Aspect 29 is a computer-readable medium storing computer executable code, where the code when executed by a processor causes the processor to implement any of Aspects 16-26.

CLAIMS

WHAT IS CLAIMED IS:

1. An apparatus for wireless communication at a user equipment (UE), comprising:
 - at least one memory; and
 - at least one processor coupled to the at least one memory and, based at least in part on information stored in the at least one memory, the at least one processor, individually or in any combination, is configured to cause the apparatus to:
 - receive, from a network entity, assistance information indicating an association between one or more grid indices and one or more transmission beams of the network entity; and
 - transmit, to the network entity, beam information based on measurement of at least one downlink signal from the network entity and the assistance information.
2. The apparatus of claim 1, further comprising a transceiver coupled to the at least one processor, the transceiver being configured to:
 - receive, from the network entity, the assistance information indicating the association between the one or more grid indices and the one or more transmission beams of the network entity; and
 - transmit, to the network entity, the beam information based on the measurement of the at least one downlink signal from the network entity and the assistance information.
3. The apparatus of claim 1, wherein the beam information is based on a predicted measurement for the one or more grid indices using an artificial intelligence or machine learning model.
4. The apparatus of claim 1, wherein the beam information comprises one or more beam identifiers (IDs) that correspond to the one or more transmission beams of the network entity.
5. The apparatus of claim 1, wherein the one or more grid indices indicate a grid location within an azimuth and elevation grid.

6. The apparatus of claim 1, wherein the one or more grid indices are associated with a two-dimensional grid, with each grid index corresponding to a portion of the two-dimensional grid that comprises beam pointing angles of the one or more transmission beams of the network entity.

7. The apparatus of claim 1, wherein the beam information includes a beam prediction based on the measurement of the at least one downlink signal from the network entity on a first set of beams to predict a predicted measurement for a second set of beams based on a mapping to the one or more grid indices.

8. The apparatus of claim 7, wherein the mapping of the second set of beams with the one or more grid indices is based on one or more grid identifiers (IDs) associated with a corresponding grid index of the one or more grid indices.

9. The apparatus of claim 1, wherein the at least one processor is configured to:
measure at least one downlink signal from the network entity using a first set of beams to make a prediction for a second set of beams based on a beam prediction procedure.

10. The apparatus of claim 9, wherein the second set of beams is generated based on the assistance information.

11. The apparatus of claim 9, wherein the beam information comprises information related to the second set of beams.

12. The apparatus of claim 9, wherein the beam information comprises beam-related information associated with the beam prediction procedure, wherein the beam-related information corresponds to one or more beams from the second set of beams that are associated with at the one or more grid indices and the one or more transmission beams of the network entity.

13. The apparatus of claim 1, wherein the at least one processor is configured to:

receive, from the network entity, an indication comprising a subset of beams of the one or more transmission beams in response to transmission of the beam information; and

transmit, to the network entity, a measurement report of the subset of beams of the one or more transmission beams.

14. A method of wireless communication at a user equipment (UE), comprising:

receiving, from a network entity, assistance information indicating an association between one or more grid indices and one or more transmission beams of the network entity; and

transmitting, to the network entity, beam information based on measurement of at least one downlink signal from the network entity and the assistance information.

15. The method of claim 14, further comprising:

measuring at least one downlink signal from the network entity using a first set of beams to make a prediction for a second set of beams based on a beam prediction procedure.

16. The method of claim 14, further comprising:

receiving, from the network entity, an indication comprising a subset of beams of the one or more transmission beams in response to transmission of the beam information; and

transmitting, to the network entity, a measurement report of the subset of beams of the one or more transmission beams.

17. An apparatus for wireless communication at a network entity, comprising:

at least one memory; and

at least one processor coupled to the at least one memory and, based at least in part on information stored in the at least one memory, the at least one processor, individually or in any combination, is configured to cause the apparatus to:

provide, to a user equipment (UE), assistance information indicating an association between one or more grid indices and one or more transmission beams of the network entity; and

obtain, from the UE, beam information based on measurement of at least one downlink signal from the network entity and the assistance information.

18. The apparatus of claim 17, further comprising a transceiver coupled to the at least one processor, the transceiver being configured to:

provide, to the UE, the assistance information indicating the association between the one or more grid indices and the one or more transmission beams of the network entity; and

obtain, from the UE, the beam information based on the measurement of the at least one downlink signal from the network entity and the assistance information.

19. The apparatus of claim 17, wherein the beam information is based on a predicted measurement for the one or more grid indices using an artificial intelligence or machine learning model.

20. The apparatus of claim 17, wherein the beam information comprises one or more beam identifiers (IDs) that correspond to the one or more transmission beams of the network entity.

21. The apparatus of claim 17, wherein the one or more grid indices indicate a grid location within an azimuth and elevation grid.

22. The apparatus of claim 17, wherein the one or more grid indices are associated with a two-dimensional grid, with each grid index corresponding to a portion of the two-dimensional grid that comprises beam pointing angles of the one or more transmission beams of the network entity.

23. The apparatus of claim 17, wherein the beam information includes a beam prediction based on the measurement of the at least one downlink signal from the network entity on a first set of beams to predict a predicted measurement for a second set of beams based on a mapping to the one or more grid indices.

24. The apparatus of claim 23, wherein the mapping of the second set of beams with the one or more grid indices is based on one or more grid identifiers (IDs) associated with a corresponding grid index of the one or more grid indices.

25. The apparatus of claim 17, wherein the beam information comprises information related to a beam prediction procedure, wherein the at least one downlink signal from the network entity are measured by the UE based on a first set of beams to make a prediction for a second set of beams based on the beam prediction procedure.

26. The apparatus of claim 25, wherein the second set of beams is generated based on the assistance information.

27. The apparatus of claim 25, wherein the beam information comprises beam-related information associated with the beam prediction procedure, wherein the beam-related information corresponds to one or more beams from the second set of beams that are associated with at the one or more grid indices and the one or more transmission beams of the network entity.

28. The apparatus of claim 17, wherein the at least one processor is configured to:
provide, to the UE, an indication comprising a subset of beams of the one or more transmission beams in response to the beam information; and
obtain, from the UE, a measurement report of the subset of beams of the one or more transmission beams.

29. A method of wireless communication at a network entity, comprising:
providing, to a user equipment (UE), assistance information indicating an association between one or more grid indices and one or more transmission beams of the network entity; and
obtaining, from the UE, beam information based on measurement of at least one downlink signal from the network entity and the assistance information.

30. The method of claim 29, further comprising:

providing, to the UE, an indication comprising a subset of beams of the one or more transmission beams in response to the beam information; and

obtaining, from the UE, a measurement report of the subset of beams of the one or more transmission beams.

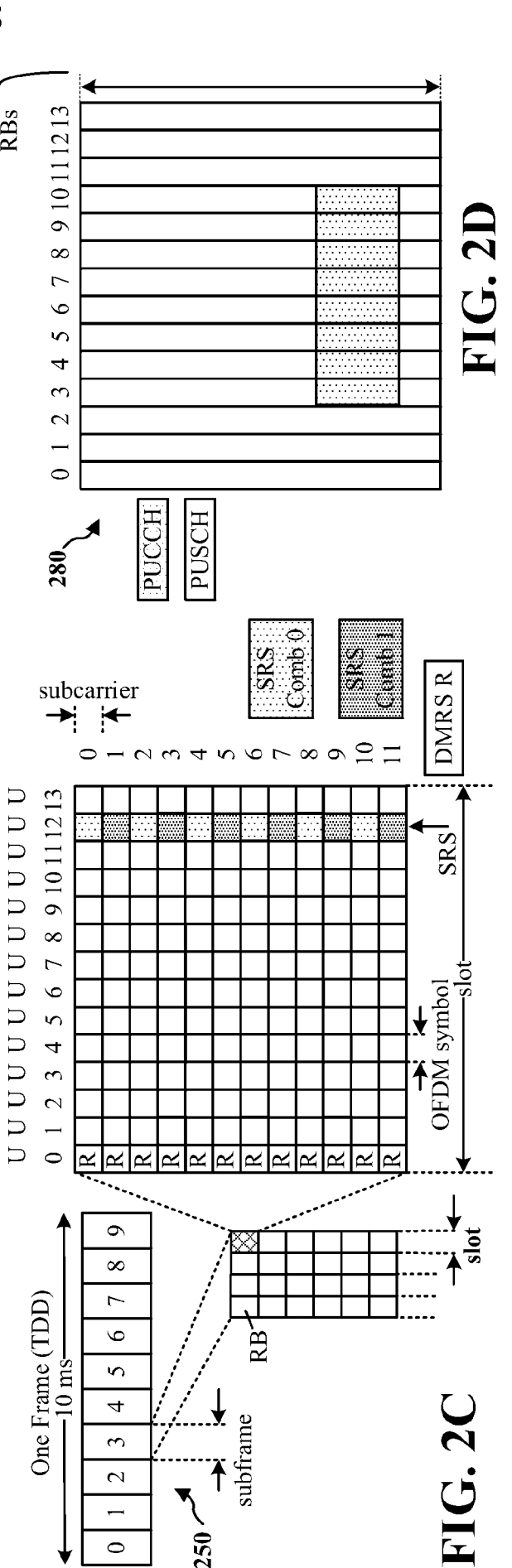
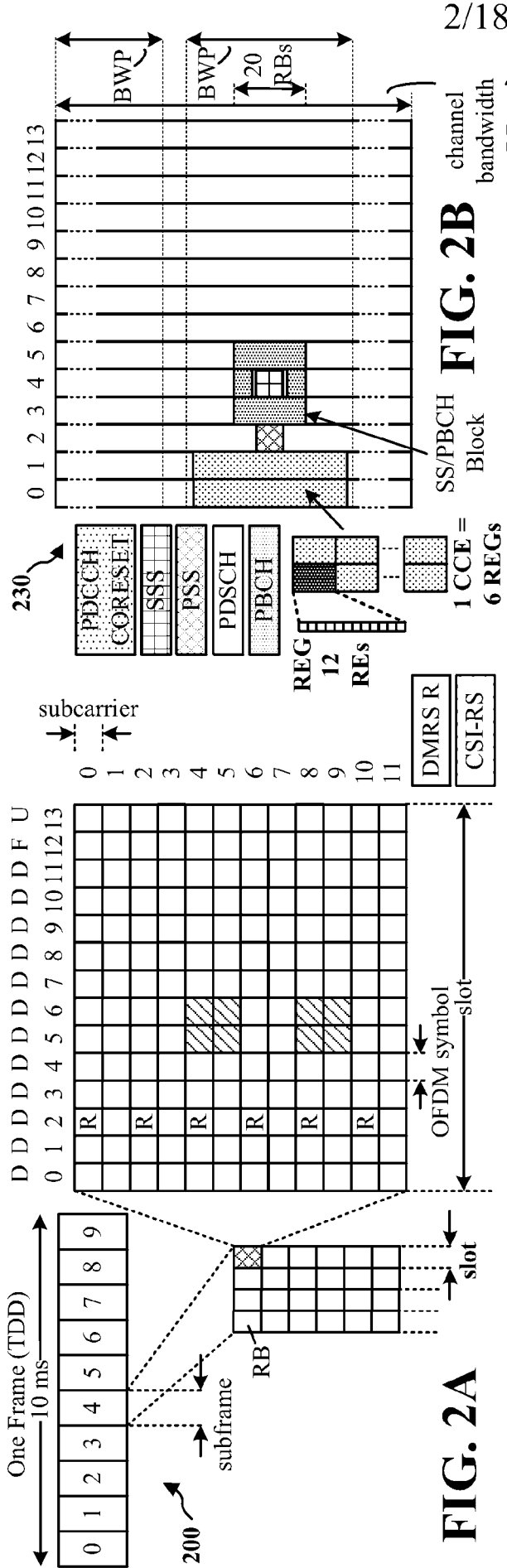

FIG. 2B

FIG. 2D

FIG. 2A

FIG. 2C

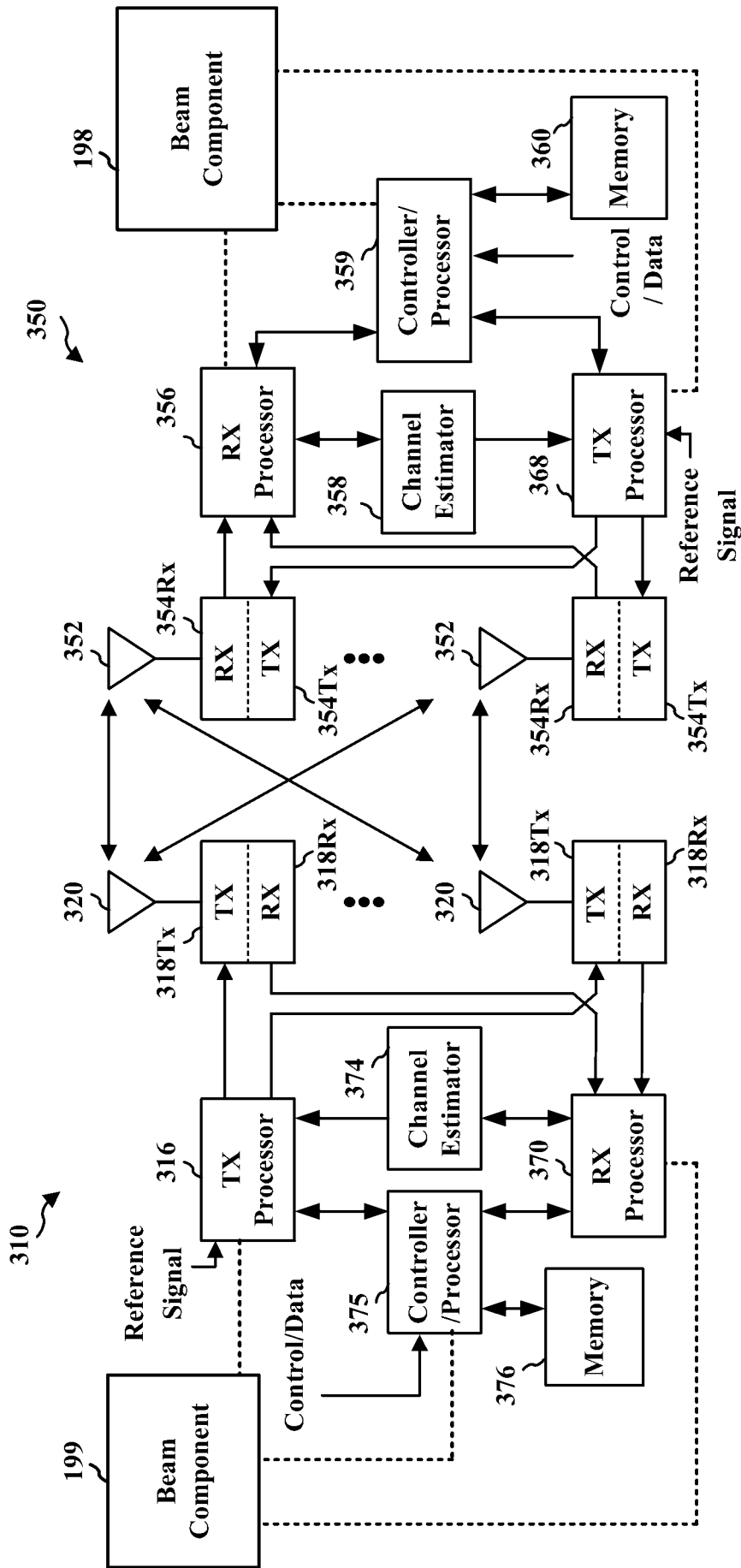

FIG. 3

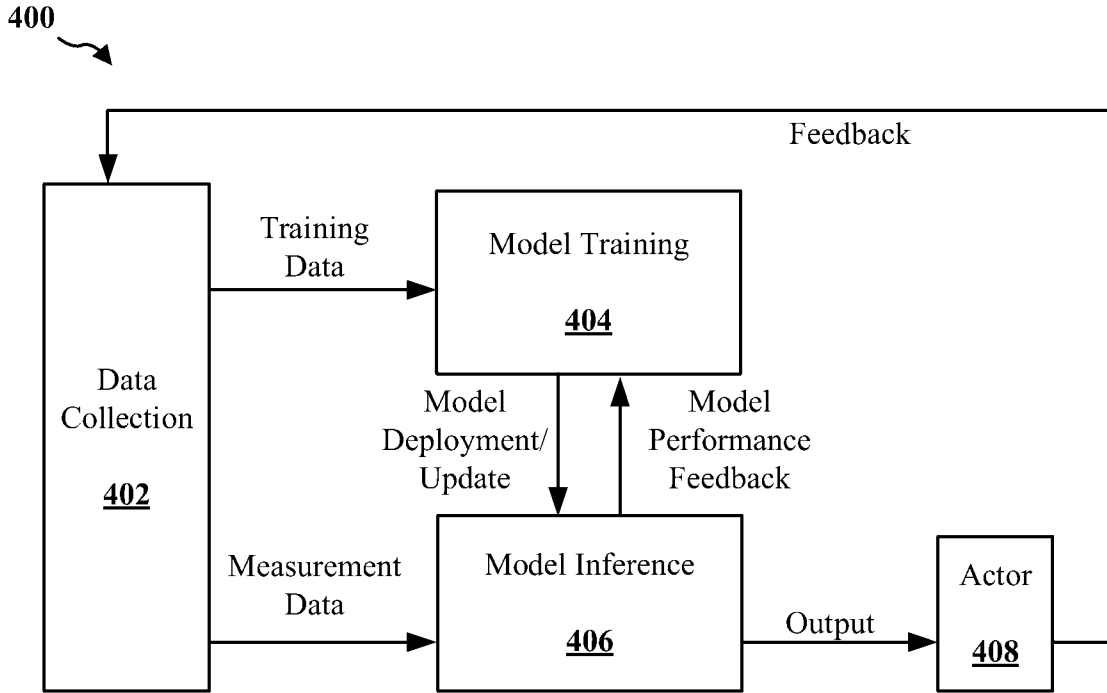

FIG. 4A

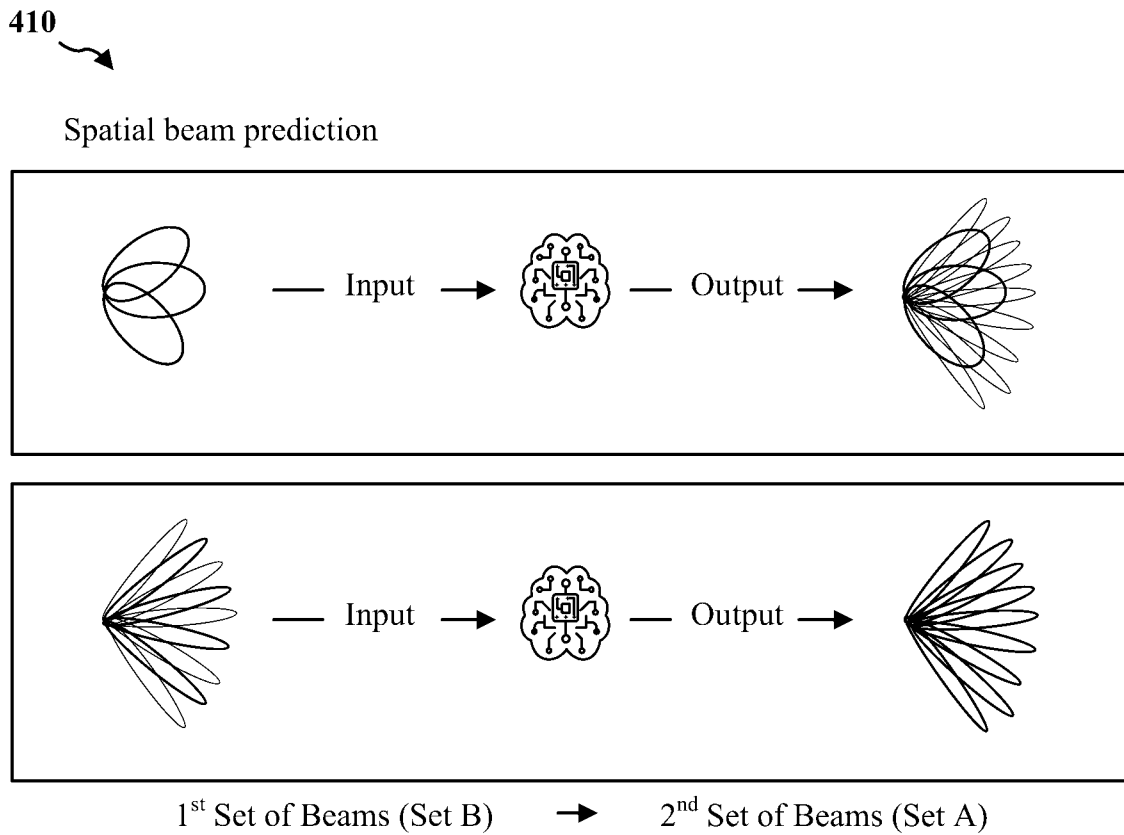

FIG. 4B

500 ↗

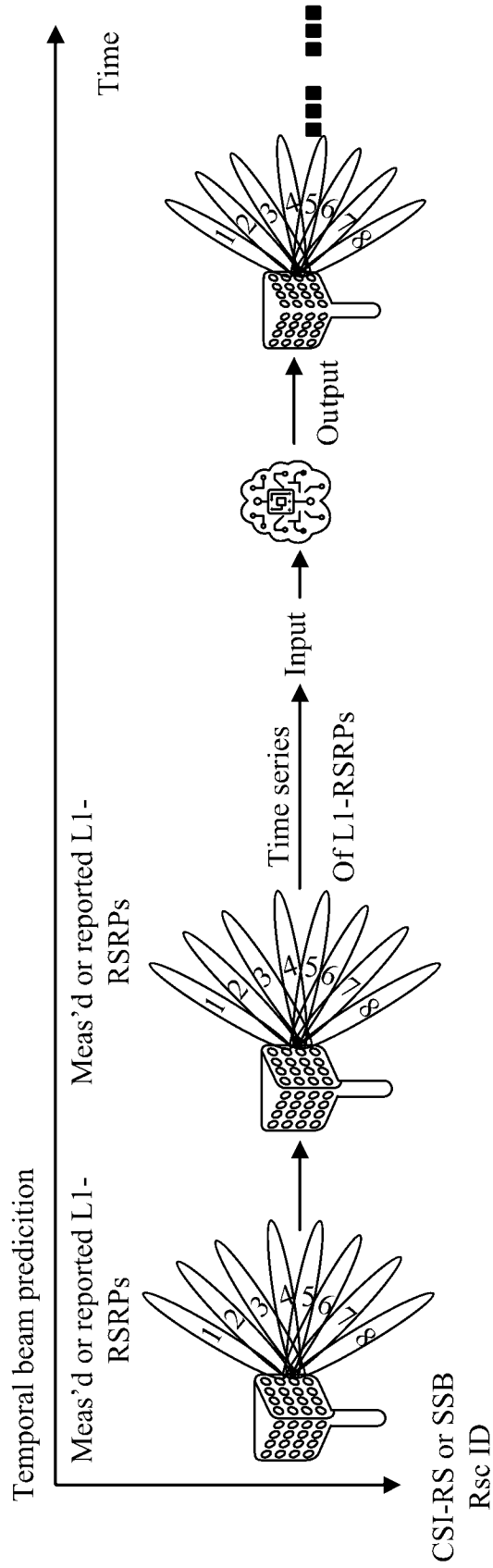

FIG. 5

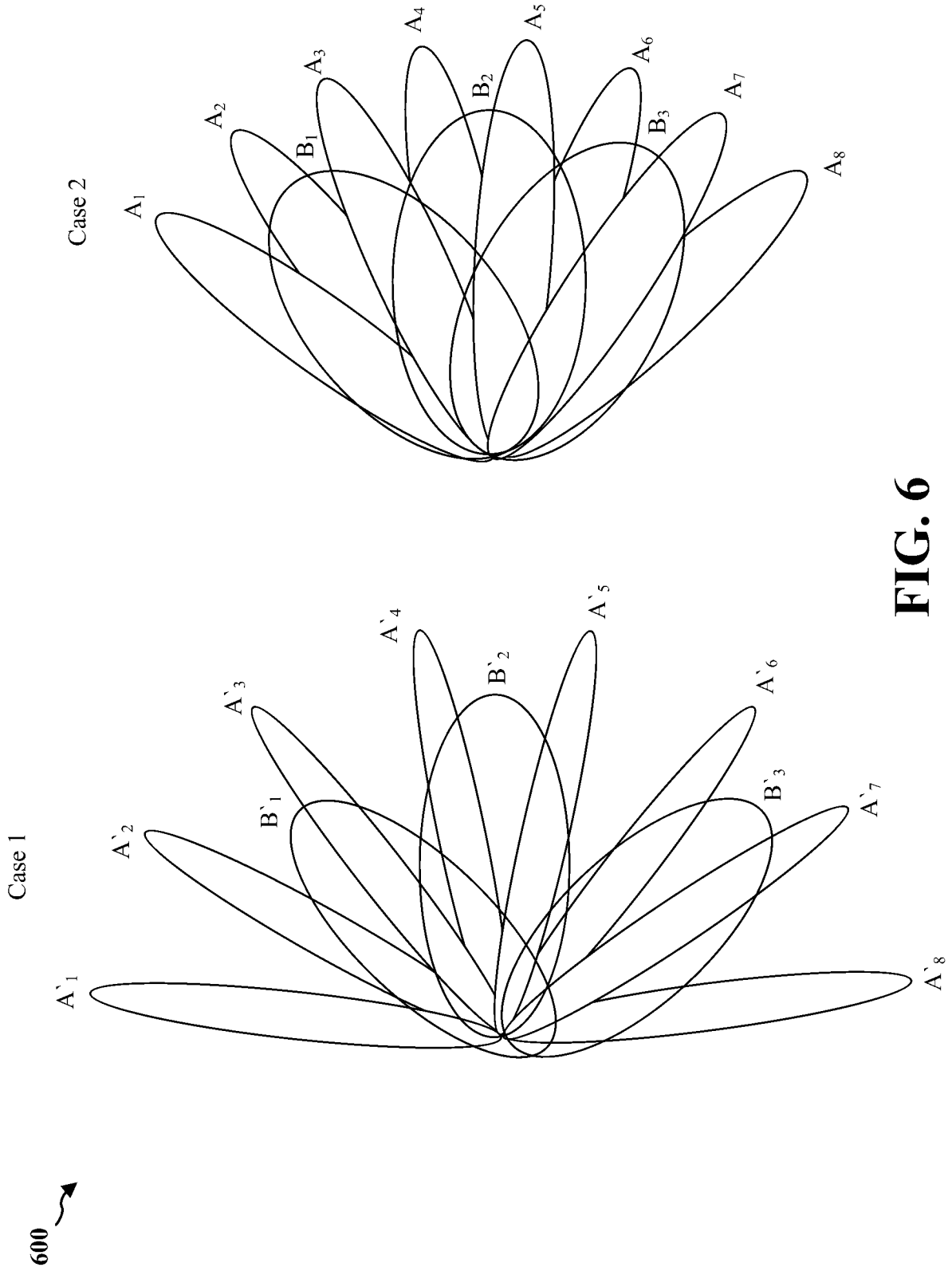

FIG. 6

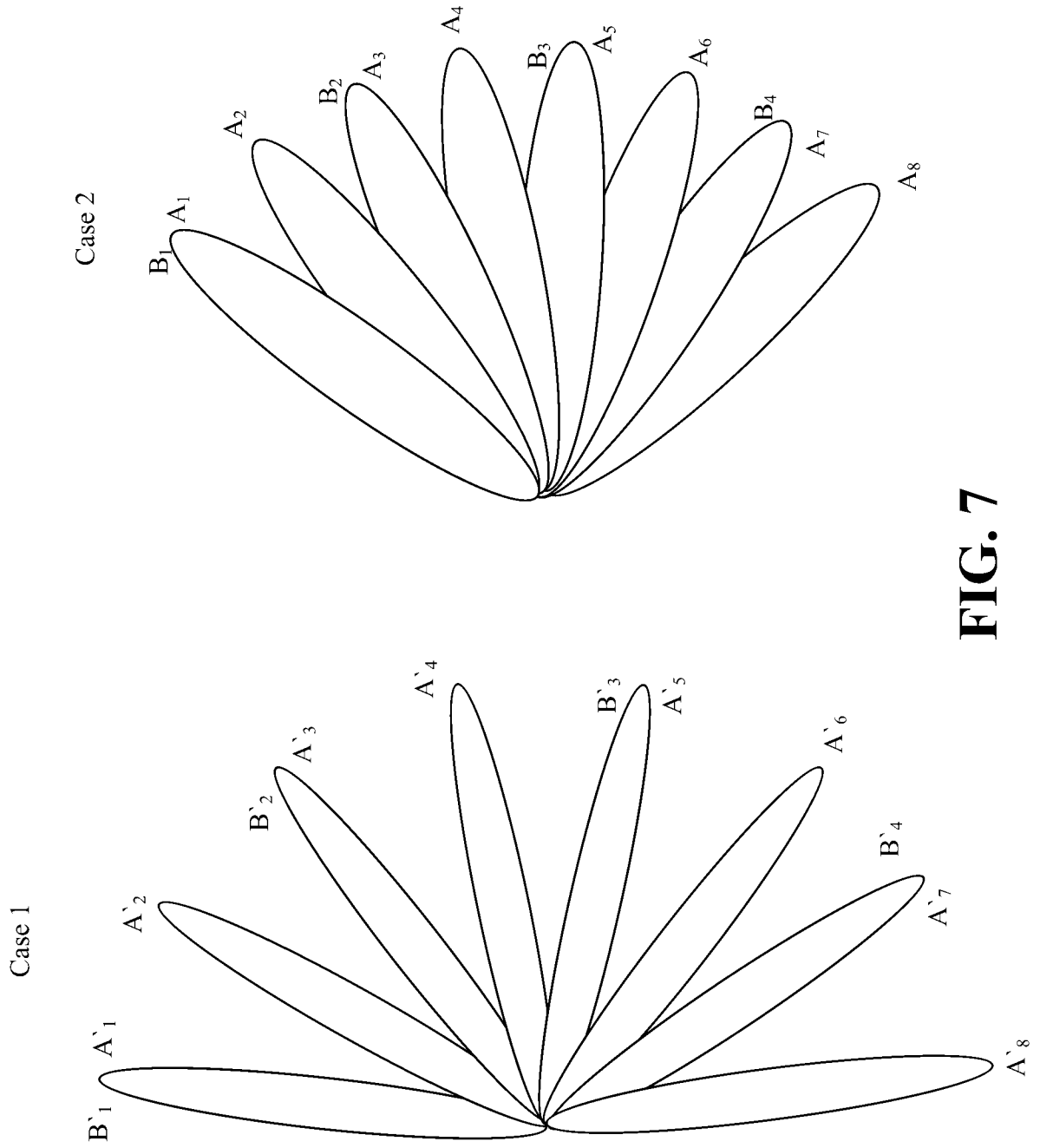

FIG. 7

800 ↗

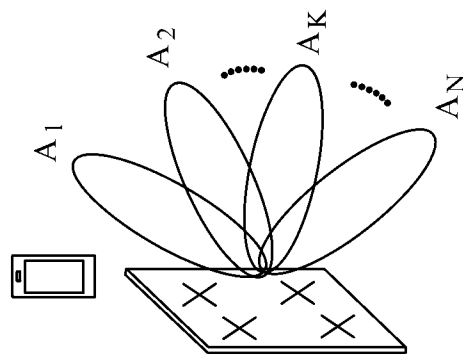
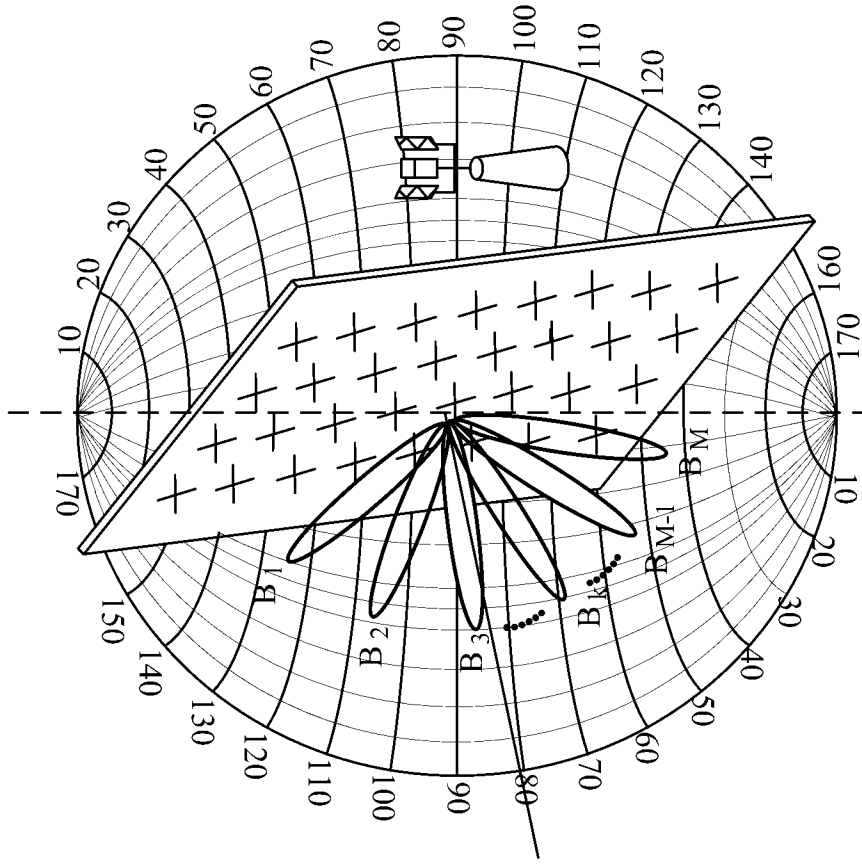

FIG. 8

900 ↗

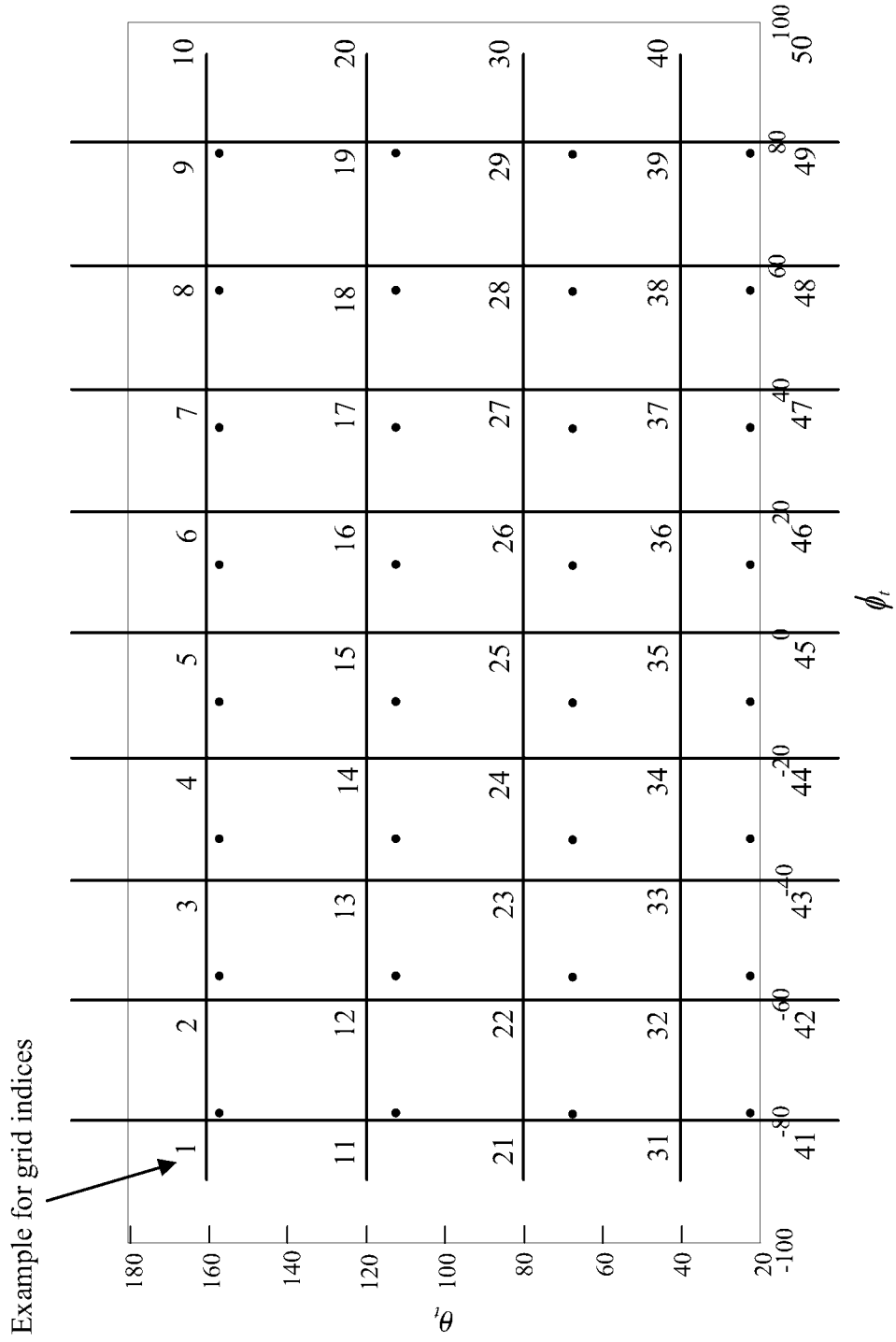

FIG. 9

1000 ↗

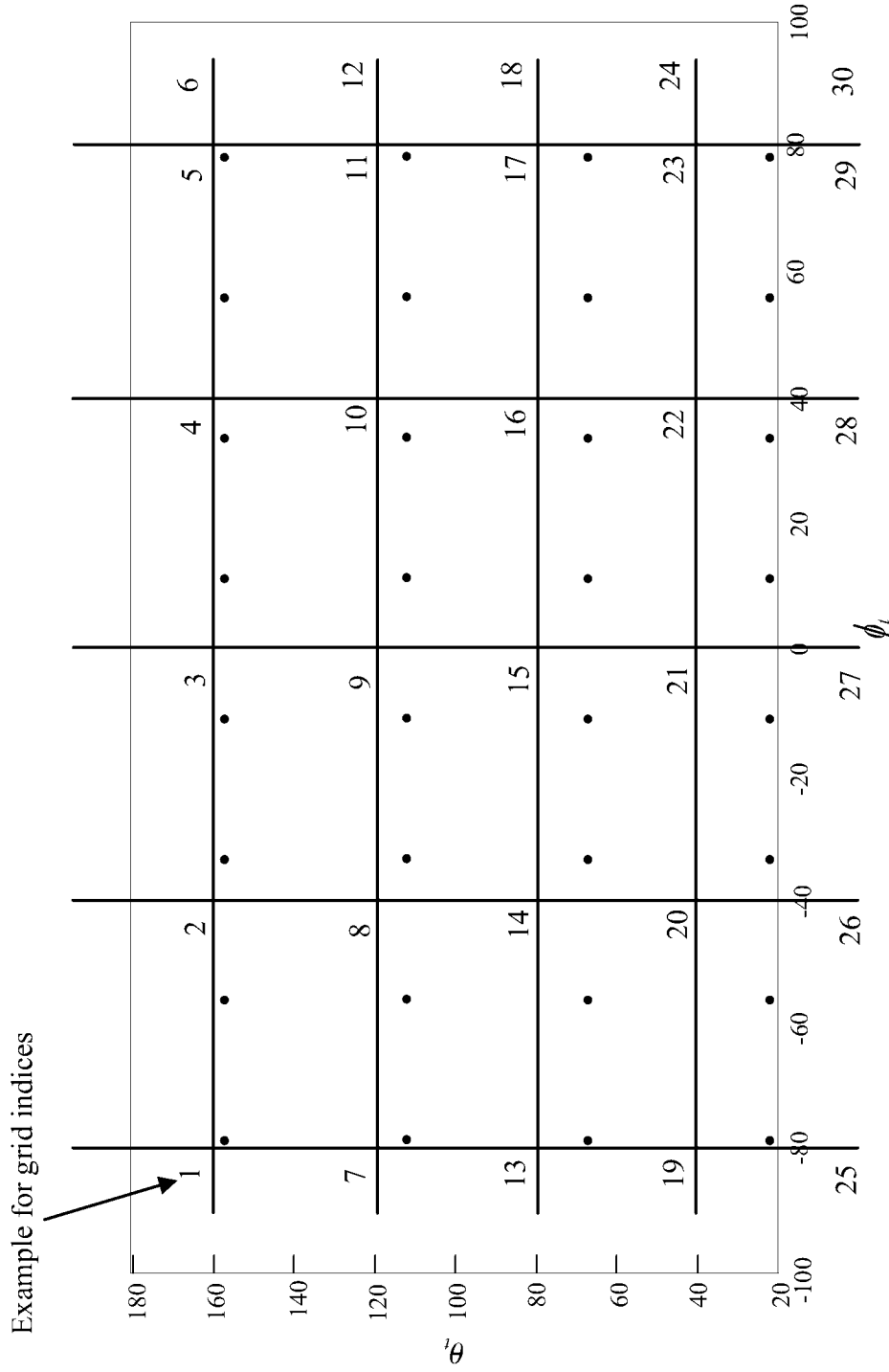

FIG. 10

1100

Example for grid indices

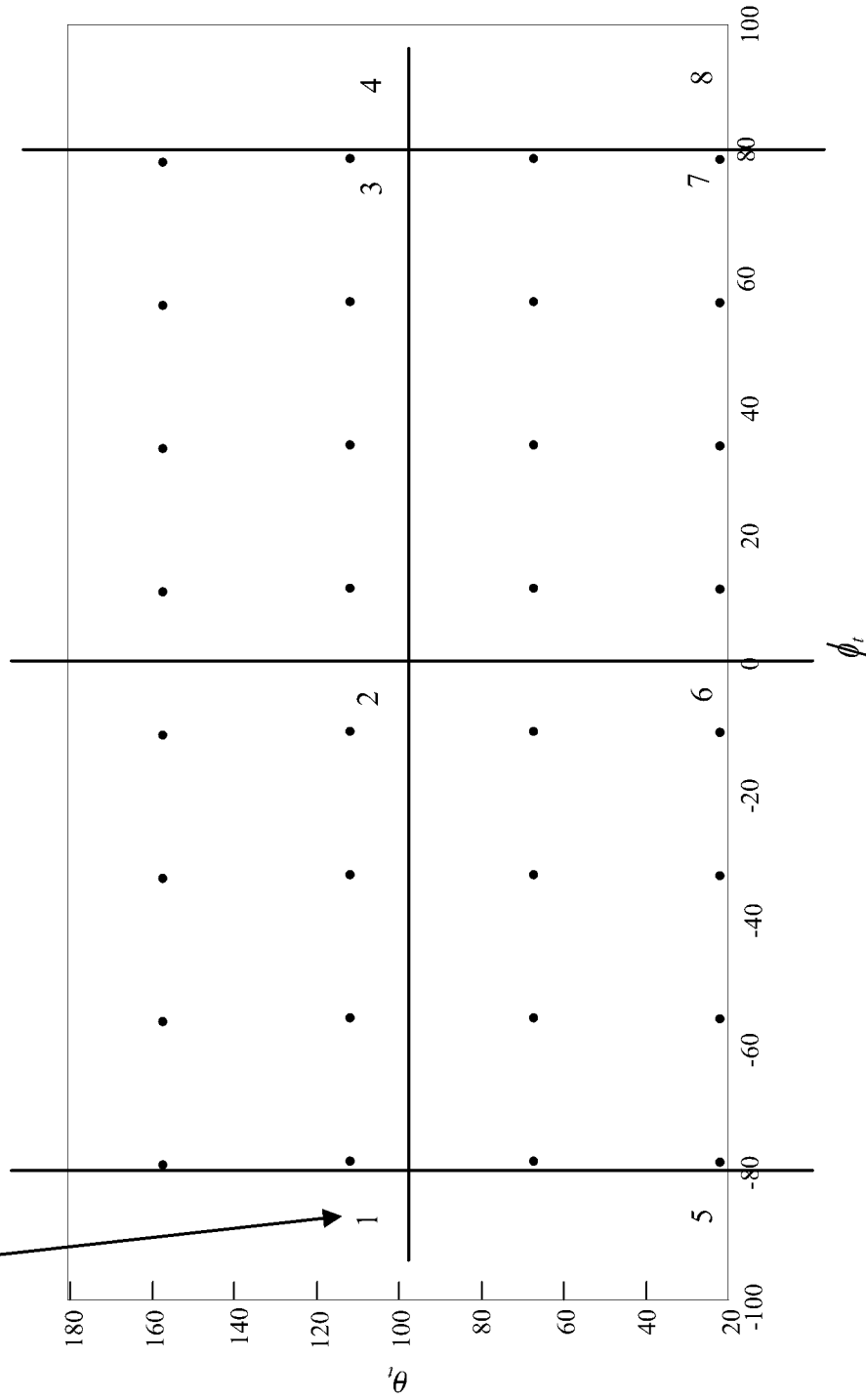

FIG. 11

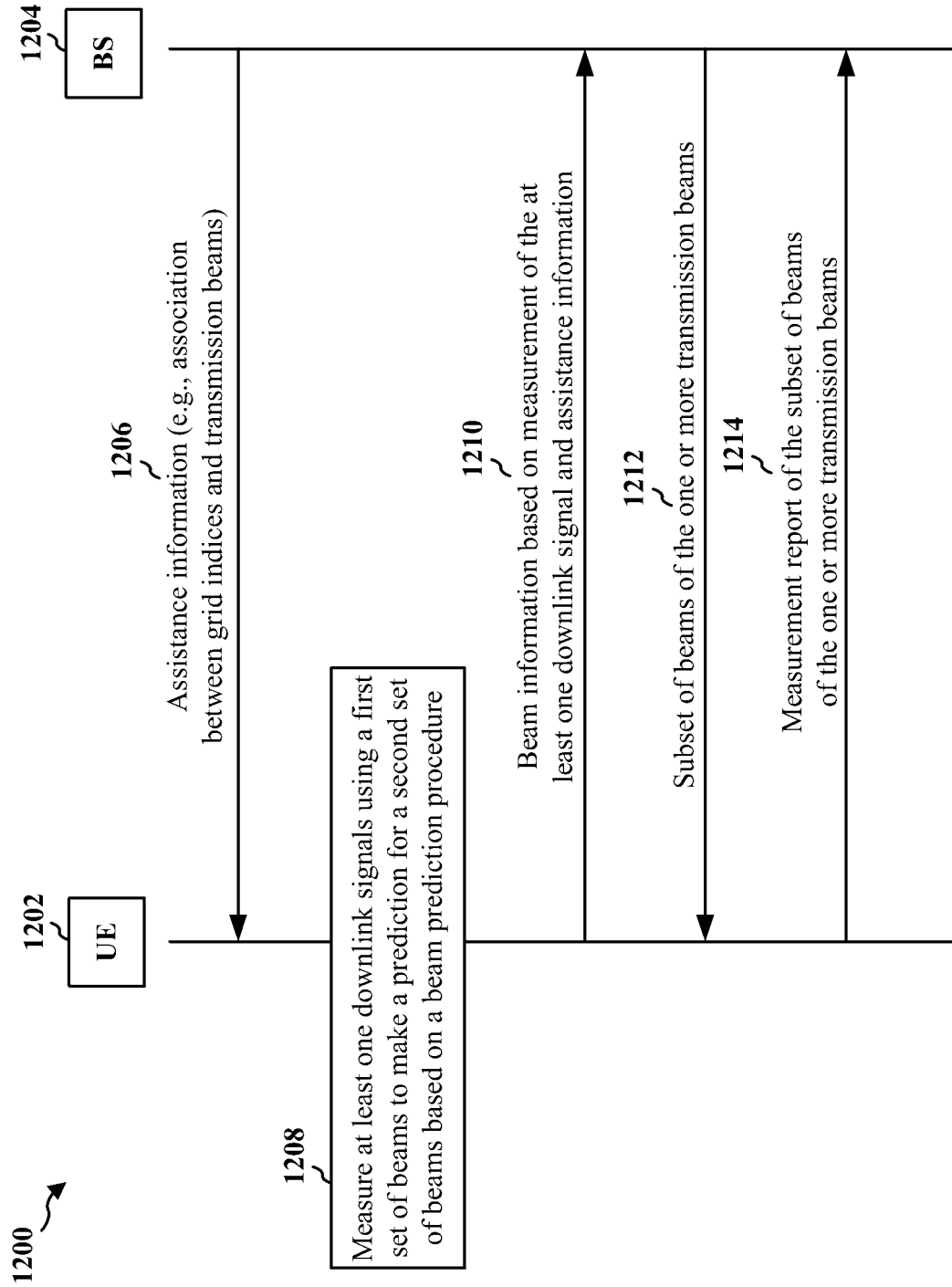

FIG. 12

1300 ↗

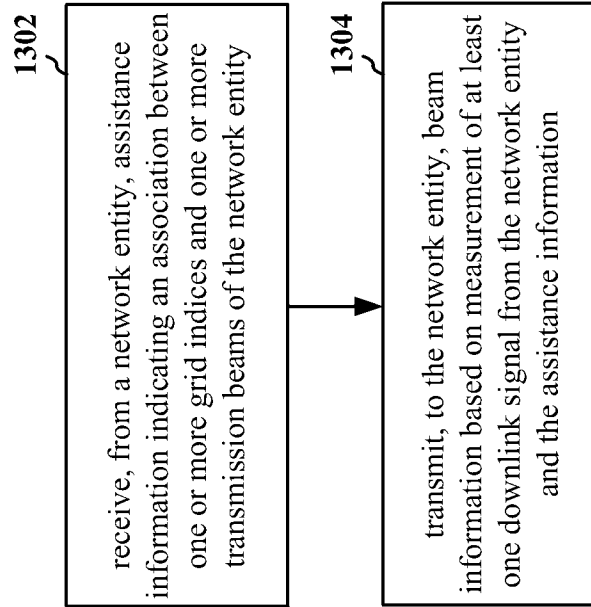

FIG. 13

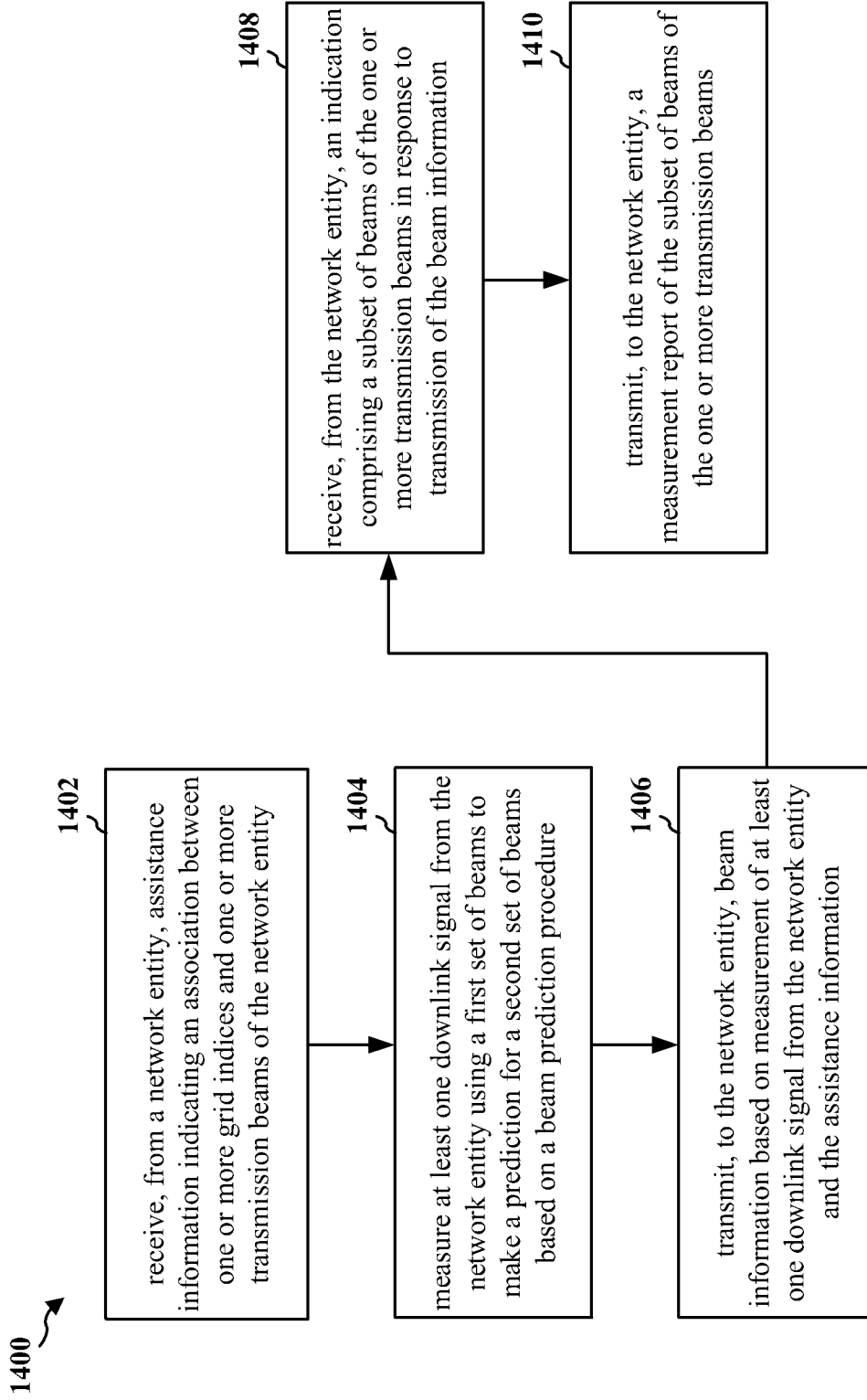

FIG. 14

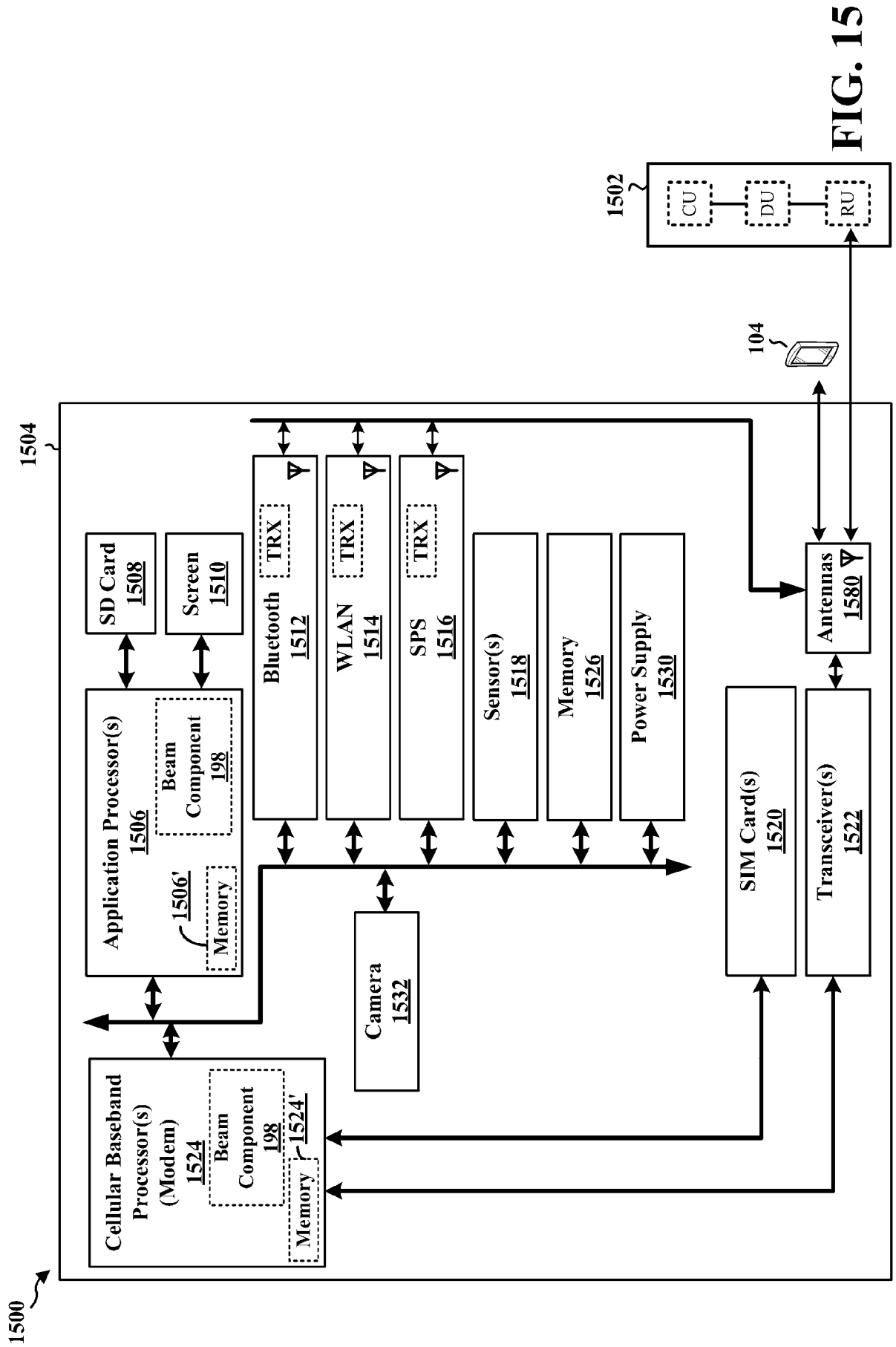

FIG. 15

1600 ↗

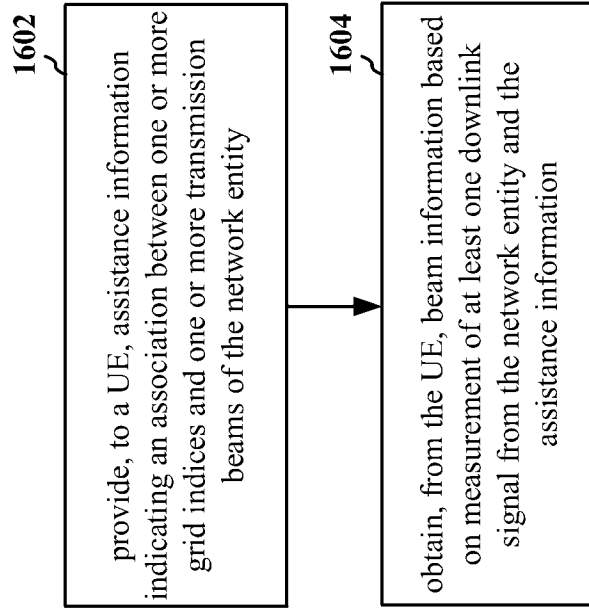

FIG. 16

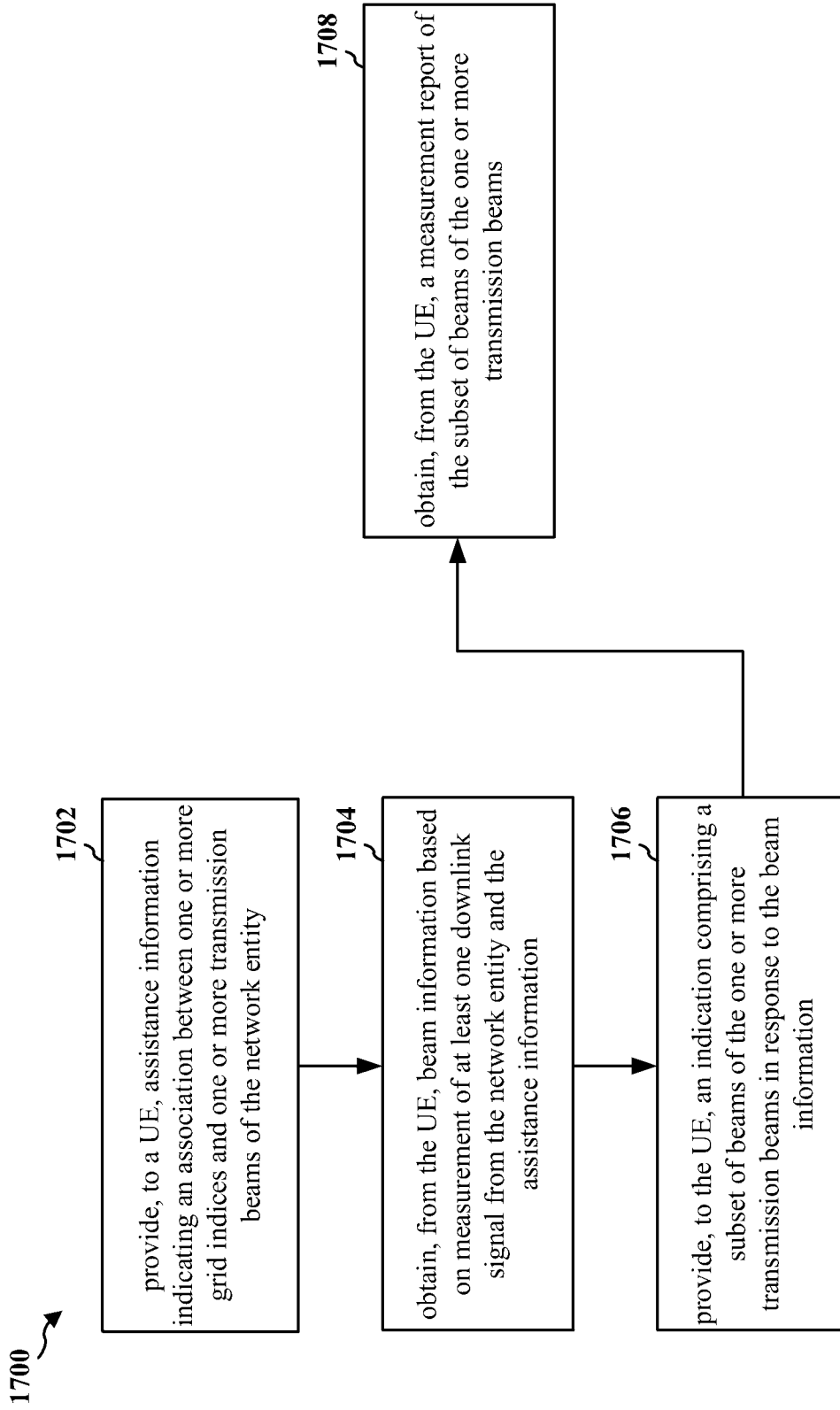

FIG. 17

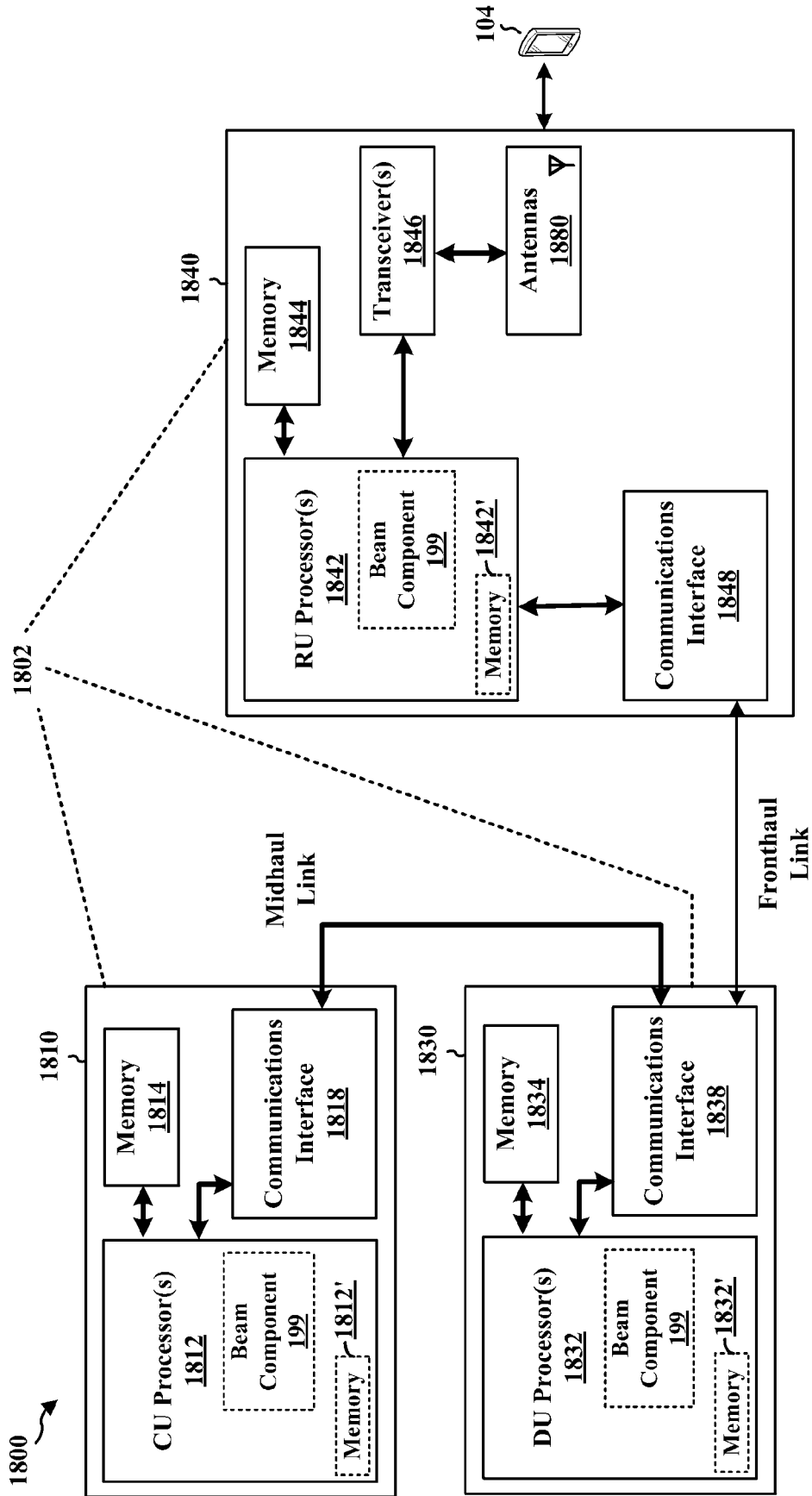

FIG. 18

INTERNATIONAL SEARCH REPORT

International application No.

PCT/CN2023/111647

A. CLASSIFICATION OF SUBJECT MATTER		
H04B 7/06(2006.01)i		
According to International Patent Classification (IPC) or to both national classification and IPC		
B. FIELDS SEARCHED		
Minimum documentation searched (classification system followed by classification symbols)		
IPC:H04B,H04W,H04L		
Documentation searched other than minimum documentation to the extent that such documents are included in the fields searched		
Electronic data base consulted during the international search (name of data base and, where practicable, search terms used)		
3GPP,CNTEXT,ENTXT,ENTXTC:angle?,grid,index,beam?,correspond+,associat+,map+,predict+,measur+		
C. DOCUMENTS CONSIDERED TO BE RELEVANT		
Category*	Citation of document, with indication, where appropriate, of the relevant passages	Relevant to claim No.
X	US 2023057661 A1 (QUALCOMM INC.) 23 February 2023 (2023-02-23) description paragraphs 0042, 0104-0118, figures 7,11,15	1-30
X	US 2019191425 A1 (QUALCOMM INC.) 20 June 2019 (2019-06-20) description paragraphs 0079-0102, figures 8-11	1-30
A	US 2022190883 A1 (NOKIA TECHNOLOGIES OY) 16 June 2022 (2022-06-16) the whole document	1-30
A	WO 2023137611 A1 (QUALCOMM INC.) 27 July 2023 (2023-07-27) the whole document	1-30
A	WO 2022272228 A1 (QUALCOMM INC.) 29 December 2022 (2022-12-29) the whole document	1-30
<input type="checkbox"/> Further documents are listed in the continuation of Box C. <input checked="" type="checkbox"/> See patent family annex.		
* Special categories of cited documents: "A" document defining the general state of the art which is not considered to be of particular relevance "D" document cited by the applicant in the international application "E" earlier application or patent but published on or after the international filing date "L" document which may throw doubts on priority claim(s) or which is cited to establish the publication date of another citation or other special reason (as specified) "O" document referring to an oral disclosure, use, exhibition or other means "P" document published prior to the international filing date but later than the priority date claimed "T" later document published after the international filing date or priority date and not in conflict with the application but cited to understand the principle or theory underlying the invention "X" document of particular relevance; the claimed invention cannot be considered novel or cannot be considered to involve an inventive step when the document is taken alone "Y" document of particular relevance; the claimed invention cannot be considered to involve an inventive step when the document is combined with one or more other such documents, such combination being obvious to a person skilled in the art "&" document member of the same patent family		
Date of the actual completion of the international search		Date of mailing of the international search report
08 April 2024		18 April 2024
Name and mailing address of the ISA/CN		Authorized officer
CHINA NATIONAL INTELLECTUAL PROPERTY ADMINISTRATION 6, Xitucheng Rd., Jimen Bridge, Haidian District, Beijing 100088, China		XU,HongYan Telephone No. (+86) 010-53961670

INTERNATIONAL SEARCH REPORT
Information on patent family members

International application No.

PCT/CN2023/111647

Patent document cited in search report			Publication date (day/month/year)	Patent family member(s)			Publication date (day/month/year)
US	2023057661	A1	23 February 2023	WO	2023022835	A1	23 February 2023
				CN	117716636	A	15 March 2024
US	2019191425	A1	20 June 2019	EP	3725009	A1	21 October 2020
				WO	2019118676	A1	20 June 2019
				CN	111543012	A	14 August 2020
US	2022190883	A1	16 June 2022	WO	2020214168	A1	22 October 2020
				EP	3956992	A1	23 February 2022
				CN	113994598	A	28 January 2020
WO	2023137611	A1	27 July 2023	None			
WO	2022272228	A1	29 December 2022	US	2023328667	A1	12 October 2023
				US	2022408381	A1	22 December 2022
				CN	117501640	A	02 February 2024