

(12) 按照专利合作条约所公布的国际申请

(19) 世界知识产权组织
国际局

(43) 国际公布日
2019年3月14日 (14.03.2019)



(10) 国际公布号
WO 2019/047544 A1

(51) 国际专利分类号:
H04L 1/00 (2006.01)

(21) 国际申请号: PCT/CN2018/085529

(22) 国际申请日: 2018年5月4日 (04.05.2018)

(25) 申请语言: 中文

(26) 公布语言: 中文

(30) 优先权:
201710807301.9 2017年9月8日 (08.09.2017) CN

(71) 申请人: 华为技术有限公司 (HUAWEI TECHNOLOGIES CO., LTD.) [CN/CN]; 中国广东省深圳市龙岗区坂田华为总部办公楼, Guangdong 518129 (CN)。

(72) 发明人: 黄凌晨 (HUANG, Lingchen); 中国广东省深圳市龙岗区坂田华为总部办公楼, Guangdong 518129 (CN)。 戴胜辰 (DAI, Shengchen); 中国广东省深圳市龙岗区坂田华为总部办公楼, Guangdong 518129 (CN)。 徐晨 (XU, Chen); 中国广东省深圳市龙岗区坂田华为总部办公楼, Guangdong 518129 (CN)。 乔云飞 (QIAO, Yunfei); 中国广东省深圳市龙岗区坂田华为总部办公楼, Guangdong 518129 (CN)。 李榕 (LI, Rong); 中国广东省深圳市龙岗区坂田华为总部办公楼, Guangdong 518129 (CN)。

(81) 指定国 (除另有指明, 要求每一种可提供的国家保护): AE, AG, AL, AM, AO, AT, AU, AZ, BA, BB, BG, BH, BN, BR, BW, BY, BZ, CA, CH, CL, CN, CO, CR, CU, CZ, DE, DJ, DK, DM, DO, DZ, EC, EE, EG, ES, FI, GB,

(54) Title: ENCODING METHOD AND DEVICE

(54) 发明名称: 编码方法及装置



图 3

- S101 A sending terminal performs CRC encoding, according to a CRC polynomial, on A information bits to be encoded, to obtain a first bit sequence, the first bit sequence comprising L CRC bits and A information bits
- S102 The sending terminal performs an interleaving operation on the first bit sequence, to obtain a second bit sequence
- S103 The sending terminal performs polarization encoding on the second bit sequence

(57) Abstract: The present application provides an encoding method and device. The method comprises: performing CRC encoding, according to a CRC polynomial, on A information bits to be encoded, to obtain a first bit sequence, the first bit sequence comprising L CRC bits and A information bits; and performing polarization encoding on the first bit sequence. Encoding satisfying FAR requirements is realized according to the improved CRC polynomial.

(57) 摘要: 本申请提供一种编码方法及装置。该方法包括: 对A个待编码信息比特根据CRC多项式进行CRC编码, 得到第一比特序列, 第一比特序列包括L个CRC比特和A个信息比特, 对第一比特序列进行极化编码。根据改进的CRC多项式实现了满足FAR需求的编码。

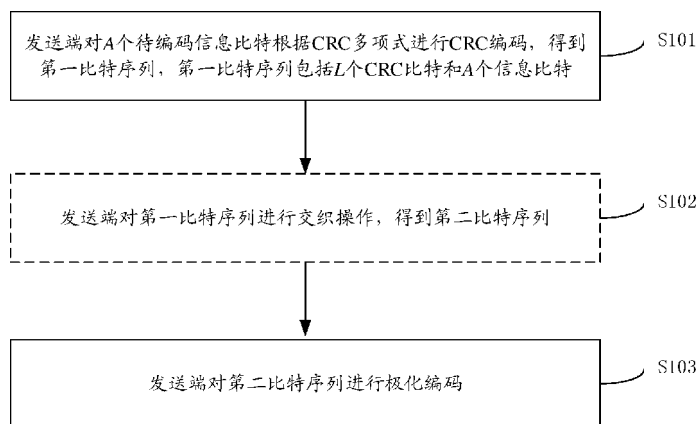
WO 2019/047544 A1

GD, GE, GH, GM, GT, HN, HR, HU, ID, IL, IN, IR, IS, JO, JP, KE, KG, KH, KN, KP, KR, KW, KZ, LA, LC, LK, LR, LS, LU, LY, MA, MD, ME, MG, MK, MN, MW, MX, MY, MZ, NA, NG, NI, NO, NZ, OM, PA, PE, PG, PH, PL, PT, QA, RO, RS, RU, RW, SA, SC, SD, SE, SG, SK, SL, SM, ST, SV, SY, TH, TJ, TM, TN, TR, TT, TZ, UA, UG, US, UZ, VC, VN, ZA, ZM, ZW。

(84) 指定国 (除另有指明, 要求每一种可提供的地区保护): ARIPO (BW, GH, GM, KE, LR, LS, MW, MZ, NA, RW, SD, SL, ST, SZ, TZ, UG, ZM, ZW), 欧亚 (AM, AZ, BY, KG, KZ, RU, TJ, TM), 欧洲 (AL, AT, BE, BG, CH, CY, CZ, DE, DK, EE, ES, FI, FR, GB, GR, HR, HU, IE, IS, IT, LT, LU, LV, MC, MK, MT, NL, NO, PL, PT, RO, RS, SE, SI, SK, SM, TR), OAPI (BF, BJ, CF, CG, CI, CM, GA, GN, GQ, GW, KM, ML, MR, NE, SN, TD, TG)。

本国际公布:

— 包括国际检索报告 (条约第21条(3))。

ENCODING METHOD AND APPARATUS

TECHNICAL FIELD

[0001] This application relates to the field of communications technologies, and in particular, to an encoding method and apparatus.

5

BACKGROUND

[0002] In a communications system, channel encoding is usually performed to improve reliability of data transmission and ensure quality of communication. Currently, a 5G mobile communications system includes three major application scenarios: enhanced mobile broadband (Enhanced Mobile Broad Band, eMBB), URLLC, and massive machine-type communications (Massive Machine-Type Communications, mMTC), new requirements are put forward for data communication, and a polar (polar) code is a first channel encoding method that can be strictly proved to "have reached" a channel capacity, and may be applicable to a 5G communications system and a future communications system.

SUMMARY

[0003] This application provides an encoding method and apparatus.

15 **[0004]** According to a first aspect, this application provides an encoding method, including: performing, by a transmit end based on a cyclic redundancy check (CRC) polynomial, CRC encoding on A to-be-encoded information bits, to obtain a first bit sequence, where the first bit sequence includes L CRC bits and A information bits, L and A are positive integers, $L=11$, and the CRC polynomial is any one of the following polynomials:

20 $D^{11}+D^{10}+D^9+D^5+1;$
 $D^{11}+D^7+D^6+D^2+1;$
 $D^{11}+D^{10}+D^9+D^6+D^4+D^2+1;$
 $D^{11}+D^{10}+D^9+D^7+D^5+D+1;$
 $D^{11}+D^9+D^8+D^6+D^5+D+1;$
25 $D^{11}+D^{10}+D^9+D^8+D^7+D^5+D^4+D+1;$
 $D^{11}+D^{10}+D^3+D+1;$
 $D^{11}+D^5+D^3+D+1;$

$$D^{11}+D^{10}+D^9+D^8+D^6+D^5+D^3+D+1;$$

$$D^{11}+D^{10}+D^8+D^7+D^6+D^5+D^3+D+1;$$

$$D^{11}+D^9+D^7+D^6+D^5+D^4+D^3+D+1;$$

$$D^{11}+D^{10}+D^9+D^7+D^6+D^3+D^2+D+1; \text{ or}$$

5 $D^{11}+D^8+D^6+D^5+D^4+D^3+D^2+D+1; \text{ and}$

performing polar encoding on the first bit sequence.

[0005] By using this encoding manner, an FAR requirement may be satisfied, to ensure that communication is normally performed.

[0006] In a possible design, the CRC polynomial is implemented by using a shift register.

10 **[0007]** In a possible design, the L CRC bits in the first bit sequence are located after the A to-be-encoded information bits.

[0008] In a possible design, the transmit end sends the first polar-encoded bit sequence.

[0009] In a possible design, the encoding method may be implemented by using hardware, for example, implemented by using a circuit or one or more integrated circuits. The encoding method
15 may alternatively be implemented by using software. For example, one or more processors perform the encoding method by reading an instruction stored in a memory. The one or more processors may be integrated in a chip, or may be distributed in a plurality of chips. The encoding method may alternatively be partially implemented by using hardware and partially implemented by using software. For example, a processor performs the step of "performing, based on a cyclic redundancy
20 check (CRC) polynomial, CRC encoding on A to-be-encoded information bits, to obtain a first bit sequence" by reading an instruction stored in a memory, and the step of "performing polar encoding on the first bit sequence" is implemented by using a logic circuit or an accelerator. Certainly, during specific implementation, persons skilled in the art may alternatively use a combination of the foregoing manners.

25 **[0010]** In a possible design, the transmit end is a base station or a terminal.

[0011] According to a second aspect, this application provides an encoding apparatus, including:
a first encoding module, configured to perform, based on a cyclic redundancy check (CRC)
polynomial, CRC encoding on A to-be-encoded information bits, to obtain a first bit sequence, where
the first bit sequence includes L CRC bits and A information bits, L and A are positive integers, $L=11$,
30 and the CRC polynomial is any one of the following polynomials:

$$D^{11}+D^{10}+D^9+D^5+1;$$

$$D^{11}+D^7+D^6+D^2+1;$$

$$D^{11}+D^{10}+D^9+D^6+D^4+D^2+1;$$

$$D^{11}+D^{10}+D^9+D^7+D^5+D+1;$$

$D^{11}+D^9+D^8+D^6+D^5+D+1;$
 $D^{11}+D^{10}+D^9+D^8+D^7+D^5+D^4+D+1;$
 $D^{11}+D^{10}+D^3+D+1;$
 $D^{11}+D^5+D^3+D+1;$
5 $D^{11}+D^{10}+D^9+D^8+D^6+D^5+D^3+D+1;$
 $D^{11}+D^{10}+D^8+D^7+D^6+D^5+D^3+D+1;$
 $D^{11}+D^9+D^7+D^6+D^5+D^4+D^3+D+1;$
 $D^{11}+D^{10}+D^9+D^7+D^6+D^3+D^2+D+1;$ or
 $D^{11}+D^8+D^6+D^5+D^4+D^3+D^2+D+1;$ and

10 a second encoding module, configured to perform polar encoding on the first bit sequence.

[0012] In a possible design, the CRC polynomial is implemented by using a shift register.

[0013] In a possible design, the L CRC bits in the first bit sequence are located after the A to-be-encoded information bits.

[0014] In a possible design, the apparatus further includes a sending module, configured to send
15 the first polar-encoded bit sequence.

[0015] In a possible design, the apparatus is a base station or a terminal.

[0016] According to a third aspect, this application provides an encoding apparatus, including a processor. The processor is configured to:

perform, based on a cyclic redundancy check (CRC) polynomial, CRC encoding on A to-
20 be-encoded information bits, to obtain a first bit sequence, where the first bit sequence includes L
CRC bits and A information bits, L and A are positive integers, $L=11$, and the CRC polynomial is any
one of the following polynomials:

$D^{11}+D^{10}+D^9+D^5+1;$
 $D^{11}+D^7+D^6+D^2+1;$
25 $D^{11}+D^{10}+D^9+D^6+D^4+D^2+1;$
 $D^{11}+D^{10}+D^9+D^7+D^5+D+1;$
 $D^{11}+D^9+D^8+D^6+D^5+D+1;$
 $D^{11}+D^{10}+D^9+D^8+D^7+D^5+D^4+D+1;$
 $D^{11}+D^{10}+D^3+D+1;$
30 $D^{11}+D^5+D^3+D+1;$
 $D^{11}+D^{10}+D^9+D^8+D^6+D^5+D^3+D+1;$
 $D^{11}+D^{10}+D^8+D^7+D^6+D^5+D^3+D+1;$
 $D^{11}+D^9+D^7+D^6+D^5+D^4+D^3+D+1;$
 $D^{11}+D^{10}+D^9+D^7+D^6+D^3+D^2+D+1;$ or

$D^{11}+D^8+D^6+D^5+D^4+D^3+D^2+D+1$; and

perform polar encoding on the first bit sequence.

[0017] In a possible design, the encoding apparatus further includes a memory, and the memory is configured to store a program instruction.

5 [0018] In a possible design, the CRC polynomial is implemented by using a shift register.

[0019] In a possible design, the L CRC bits in the first bit sequence are located after the A to-be-encoded information bits.

[0020] In a possible design, the apparatus is a base station or a terminal.

10 [0021] The memory may be inside the processor or outside the processor. The processor may be integrated in the terminal or base station.

[0022] The processor may be a circuit, one or more integrated circuits, or one or more dedicated chips. The processor may alternatively be a general-purpose chip, and when the program instruction used to implement the encoding method is loaded into the processor, the foregoing encoding function may be implemented. The processor may alternatively be a combination of one or more of a circuit,
15 an integrated circuit, a dedicated chip, and a general-purpose chip.

[0023] According to a fourth aspect, this application provides an encoding apparatus, including:
an input interface, configured to obtain a to-be-encoded bit sequence;
a logic circuit, configured to perform the method according to any one of claims 1 to 4
based on the obtained to-be-encoded bit sequence, to obtain encoded bits; and

20 an output interface, configured to output the encoded bits.

[0024] In a possible design, the apparatus is a base station or a terminal.

[0025] According to a fifth aspect, this application provides a communications device, including the encoding apparatus provided in the third aspect and the possible designs of the third aspect and a transceiver, where

25 the transceiver is configured to send bits encoded by the encoding apparatus.

[0026] In a possible design, the communications device is a base station or a terminal.

[0027] According to a sixth aspect, this application provides a readable storage medium, including a readable storage medium and a computer program. The computer program is used to implement the encoding method provided in the first aspect and the possible designs of the first aspect.

30 [0028] According to a seventh aspect, this application provides a program product. The program product includes a computer program. The computer program is stored in a readable storage medium. At least one processor of an encoding apparatus may read the computer program from the readable storage medium, and the at least one processor executes the computer program, so that the encoding apparatus performs the encoding method in the first aspect and the possible designs of the first aspect.

[0029] After the CRC polynomial provided in this application is used, an FAR requirement of a system can be satisfied, to ensure that communication is normally performed.

BRIEF DESCRIPTION OF DRAWINGS

- [0030] FIG. 1(a) and FIG. 1(b) are schematic architectural diagrams of a communications system applied to an embodiment of this application;
- [0031] FIG. 2 is a schematic flowchart of a communications system;
- [0032] FIG. 3 is a flowchart of an embodiment of an encoding method according to this application;
- [0033] FIG. 4 is a schematic diagram of a CRC encoding manner;
- 10 [0034] FIG. 5 is a first schematic structural diagram of an encoding apparatus according to an embodiment of this application;
- [0035] FIG. 6 is a second schematic structural diagram of an encoding apparatus according to an embodiment of this application;
- [0036] FIG. 7 is a third schematic structural diagram of an encoding apparatus according to an embodiment of this application;
- 15 [0037] FIG. 8 is a first schematic structural diagram of a decoding apparatus according to an embodiment of this application;
- [0038] FIG. 9 is a second schematic structural diagram of a decoding apparatus according to an embodiment of this application;
- 20 [0039] FIG. 10 is a third schematic structural diagram of a decoding apparatus according to an embodiment of this application; and
- [0040] FIG. 11 is a schematic structural diagram of a network device and a terminal according to an embodiment of this application.

DESCRIPTION OF EMBODIMENTS

- 25 [0041] A polar code is a linear block code. A generator matrix of the polar code is G_N . An encoding process of the polar code is $x_1^N = u_1^N G_N$, $u_1^N = (u_1, u_2, \dots, u_N)$ is a binary row vector whose length is N (namely, a code length). $G_N = F_2^{\otimes (\log_2(N))}$, where $F_2 = \begin{bmatrix} 1 & 0 \\ 1 & 1 \end{bmatrix}$, and $F_2^{\otimes (\log_2(N))}$ is defined as a Kronecker (Kronecker) product of $\log_2 N$ matrices F_2 . x_1^N are encoded bits (also

referred to as a code word), where the encoded bits are obtained after u_1^N is multiplied by the generator matrix G_N , and a multiplication process is the encoding process. In the encoding process of the polar code, some bits of u_1^N are used to carry information and are referred to as information bits, and a set of indexes of the information bits is marked as A ; and other bits of u_1^N are set to fixed values on which a receive end and a transmit end agree in advance, and are referred to as frozen bits, and a set of indexes of the frozen bits is represented by using a complementary set A^c of A . A frozen bit is usually set to 0. Provided that the receive end and the transmit end agree in advance, a frozen bit sequence may be arbitrarily set.

[0042] To further improve encoding performance of a system, an outer code having a check capability, for example, a cyclic redundancy check (English: Cyclic Redundancy Check, CRC) code, may be concatenated with the polar. When a decoding manner such as serial cancellation list (Serial Cancellation List) decoding is used, selection is usually performed on survivor paths based on cyclic redundancy check after decoding ends, so as to improve channel encoding performance of the system. When the polar code is used for a control channel, in addition to a block error rate (block error rate, BLER) that is a normal technical indicator, a false alarm rate (false alarm rate, FAR for short) indicator further needs to be satisfied. For example, if a quantity of CRC bits is L , a decoding manner such as serial cancellation list decoding is used, cyclic redundancy check is used after decoding ends, and T paths of survivor paths are checked, an FAR is usually required to be less than $(2^{-(L+\log_2(T))})$. It should be noted that, selection on a value T does not depend on a cyclic redundancy check polynomial and a length, but depends on decoding implementation complexity, decoding performance, and the like. Therefore, how to find an appropriate manner of concatenating CRC check and a polar code according to an FAR requirement needs to be considered. This application puts emphasis on determining an appropriate CRC polynomial based on a value of L , so as to satisfy a system requirement, and ensure that communication is normally performed.

[0043] Embodiments of this application may be applied to a wireless communications system. It should be noted that, the wireless communications system mentioned in the embodiments of this application includes, but is not limited to: a Long Term Evolution (Long Term Evolution, LTE) system, and three major application scenarios of a next-generation 5G mobile communications system: enhanced mobile broadband (Enhanced Mobile Broad Band, eMBB), URLLC, and massive machine-type communications (Massive Machine-Type Communications, mMTC). Alternatively, the wireless communications system may be a device to device (Device to Device, D2D) communications system, another communications system, a future communications system, or the like.

[0044] A communications apparatus related to this application may be configured in a

communications device, and the communications device mainly includes a network device or a terminal device. If a transmit end in this application is a network device, a receive end is a terminal device; or if a transmit end in this application is a terminal device, a receive end is a network device.

5 **[0045]** In an embodiment of this application, as shown in FIG. 1(a), a communications system 100 includes a network device 110 and a terminal 112. When the wireless communications network 100 includes a core network, the network device 110 may be further connected to the core network. The network device 101 may further communicate with an IP network 200 such as the Internet (internet), a private IP network, or another data network. A network device provides a service for a terminal within coverage. For example, referring to FIG. 1(a), the network device 110 provides
10 wireless access for one or more terminals within coverage of the network device 110. In addition, an overlapping area may exist within coverage of network devices such as the network device 110 and a network device 120. Network devices may further communicate with each other. For example, the network device 110 may communicate with the network device 120.

[0046] When the network device 110 or the terminal 112 sends information or data, an encoding
15 method described in the embodiments of this application may be used. Therefore, for convenience of description, in this embodiment of this application, the communications system 100 is simplified to a system that includes a transmit end 101 and a receive end 102, as shown in FIG. 1(b). The transmit end 101 may be the network device 110, and the receive end 102 is the terminal 112; or the transmit end 101 is the terminal 112, and the receive end 102 is the network device 110. The network device
20 110 may be a device configured to communicate with the terminal device. For example, the network device 110 may be an evolved NodeB (Evolved Node B, eNB or eNodeB) in an LTE system, a network side device in a 5G network, a network side device communicating with a terminal in another network, or a network side device in a future network. Alternatively, the network device may be a relay station, an access point, an in-vehicle device, or the like. In a device to device (Device to Device,
25 D2D) communications system, the network device may be a terminal playing a role of a base station. The terminal may include various handheld devices, in-vehicle devices, wearable devices, or computing devices having a wireless communications function, or another processing device connected to a wireless modem, and various forms of user equipment (user equipment, UE), mobile stations (mobile station, MS), and the like.

30 **[0047]** An encoding process related to this application is roughly: performing CRC check on to-be-encoded information; if necessary, performing an operation such as interleaving on a CRC-checked bit sequence; and then performing polar encoding. In addition, one or more of, including but not limited to, rate matching, modulation, digital-to-analog conversion, and frequency conversion may be further performed, based on a target code length M, on encoded bits obtained after polar

encoding.

[0048] FIG. 2 is a schematic flowchart of a communications system. As shown in FIG. 2, at a transmit end, a signal source sequentially undergoes signal source encoding, channel encoding, rate matching (an optional step), and modulation, and then sending. At a receive end, the signal source sequentially undergoes demodulation, rate de-matching (an optional step), channel decoding, and signal source decoding, and is output to a signal sink. The embodiments of this application are mainly related to channel encoding and channel decoding (briefly referred to as channel encoding and decoding), and are described below by using specific examples. A polar code concatenated with CRC check may be used for channel encoding and decoding in the embodiments of this application.

[0049] This application provides an encoding method and apparatus, so as to satisfy an FAR requirement. The method and the apparatus related to this application are applicable to both a control channel and a data channel, and are applicable to both uplink and downlink. The encoding method and apparatus provided in this application are described in detail below with reference to accompanying drawings.

[0050] FIG. 3 is a flowchart of an embodiment of an encoding method according to this application. As shown in FIG. 3, this embodiment is performed by a transmit end, and the method of this embodiment may include the following steps.

[0051] S101. The transmit end performs CRC encoding on A to-be-encoded information bits based on a CRC polynomial, to obtain a first bit sequence, where the first bit sequence includes L CRC bits and A information bits, and L and A are positive integers. L is also usually referred to as a CRC length.

[0052] In consideration of an FAR requirement, when $L=11$, the CRC polynomial is any one of the following polynomials:

$$D^{11}+D^{10}+D^9+D^5+1;$$

$$D^{11}+D^7+D^6+D^2+1;$$

$$D^{11}+D^{10}+D^9+D^6+D^4+D^2+1;$$

$$D^{11}+D^{10}+D^9+D^7+D^5+D+1;$$

$$D^{11}+D^9+D^8+D^6+D^5+D+1;$$

$$D^{11}+D^{10}+D^9+D^8+D^7+D^5+D^4+D+1;$$

$$D^{11}+D^{10}+D^3+D+1;$$

$$D^{11}+D^5+D^3+D+1;$$

$$D^{11}+D^{10}+D^9+D^8+D^6+D^5+D^3+D+1;$$

$$D^{11}+D^{10}+D^8+D^7+D^6+D^5+D^3+D+1;$$

$$D^{11}+D^9+D^7+D^6+D^5+D^4+D^3+D+1;$$

$$D^{11}+D^{10}+D^9+D^7+D^6+D^3+D^2+D+1; \text{ or}$$

$$D^{11}+D^8+D^6+D^5+D^4+D^3+D^2+D+1.$$

[0053] A specific process of performing CRC encoding based on a selected polynomial is the same as current general CRC encoding.

5 **[0054]** Specifically, after receiving the A to-be-encoded information bits, the transmit end adds the L CRC bits based on the CRC polynomial, to obtain the first bit sequence.

[0055] The A to-be-encoded information bits may be obtained by sorting to-be-sent information bits in ascending or descending order, or may be obtained by performing other processing on information bits. This is not limited herein.

10 **[0056]** An implementation of CRC encoding is in a form of a shift register. For example, FIG. 4 shows a commonly used manner of implementing CRC encoding in a form of a shift register (briefly referred to as a register). A feedback tap of the register is determined by a CRC polynomial D^4+D^2+1 , and content of the register is initialized to a preset value. During encoding, the to-be-encoded information bits are shifted from a side into the register bit by bit, and a bit exclusive-OR
15 operation is performed on the feedback tap and a corresponding register status, so that the register status changes. After all to-be-encoded bits are shifted into the register, bits 0 whose quantity is equal to a quantity of bits of the CRC length are shifted into the register, then the register status is read, and the register status is used as a CRC bit, and is used as a code word of CRC encoding. The L CRC bits in the first bit sequence may be located after the A to-be-encoded information bits, may be located
20 before the A to-be-encoded information bits, or may be located at any location on which a receive end and the transmit end agree.

[0057] S102. The transmit end interleaves the first bit sequence, to obtain a second bit sequence.

[0058] In the interleaving step, some bits in the first bit sequence may be interleaved, or all bits in the first bit sequence may be interleaved. It should be noted that, this step is an optional step: This
25 step is necessary only when a location of an information bit and/or a CRC check bit needs to be adjusted; and if the location of the information bit and/or the CRC check bit does not need to be adjusted, this step may be omitted in an actual encoding process, and in this case, the second bit sequence in step S103 is the first bit sequence. A specific interleaving scheme is not content of this application, and details are not described.

30 **[0059]** S103. The transmit end performs polar encoding on the second bit sequence, to obtain a third bit sequence. When step S102 is omitted, this step is: The transmit end performs polar encoding on the first bit sequence, to obtain a third bit sequence.

[0060] An existing polar encoding method may be used as an encoding method for performing, by the transmit end, polar encoding on the second bit sequence. Details are not described herein.

[0061] S104 (not shown in the figure). The transmit end performs some or all steps of, including but not limited to, rate matching, modulation, analog-to-digital conversion, and frequency conversion on the third bit sequence, and then sends the third bit sequence.

[0062] It should be noted that, the rate matching step in step S104 is optional. If an encoding code length is the same as a code length of a target code, rate matching is not needed. This embodiment of the present invention does not emphasize step S104. Therefore, details are not described herein. For example, in a possible implementation, persons skilled in the art may make reference to practices in the prior art.

[0063] Based on the encoding method provided in this embodiment, the transmit end performs CRC encoding on the A to-be-encoded information bits based on the CRC polynomial provided in this application, to obtain the first bit sequence, and then performs interleaving (if necessary) and polar encoding on the first bit sequence. Therefore, after CRC is concatenated, the used polar encoding manner can satisfy the FAR requirement.

[0064] It should be noted that, after receiving to-be-decoded information bits, the receive end (a decoder side) also needs to perform CRC check based on the same CRC polynomial. Details are not described herein.

[0065] In this embodiment of this application, a decoding operation at the decoder end is roughly: receiving a to-be-decoded sequence, and performing polar decoding on the obtained to-be-decoded sequence based on a CRC polynomial.

[0066] Based on an inventive idea the same as that of the encoding method shown in FIG. 3, as shown in FIG. 5, an embodiment of this application further provides an apparatus 700. The encoding apparatus 700 is configured to perform the encoding method shown in FIG. 3. Some or all steps of the encoding method shown in FIG. 3 may be performed by using hardware or by using software. When some or all steps of the encoding method shown in FIG. 3 are performed by using hardware, the encoding apparatus 700 includes: an input interface 701, configured to obtain a to-be-encoded bit sequence; a logic circuit 702, configured to perform the encoding method shown in FIG. 3, where for details, refer to the description in the foregoing method embodiment, and details are not described herein again; and an output interface 703, configured to output an encoded bit sequence.

[0067] Optionally, during specific implementation, the encoding apparatus 700 may be a chip or an integrated circuit.

[0068] Optionally, when some or all steps of the encoding method of the foregoing embodiment are performed by using software, as shown in FIG. 6, an encoding apparatus 800 includes: a memory 801, configured to store a program; and a processor 802, configured to execute the program stored in the memory 801. When the program is executed, the encoding apparatus 800 performs the encoding

method provided in the embodiment in FIG. 3.

[0069] Optionally, the memory 801 may be a physically independent unit, or may be integrated together with the processor 802.

[0070] Optionally, when some or all steps of the encoding method of the embodiment in FIG. 3 are performed by using software, the encoding apparatus 800 may include only the processor 802. The memory 801 configured to store the program is located outside the encoding apparatus 800, and the processor 802 is connected to the memory 801 by using a circuit or a wire, and is configured to read and execute the program stored in the memory 801.

[0071] The processor 802 may be a central processing unit (central processing unit, CPU), a network processor (network processor, NP), or a combination of a CPU and an NP.

[0072] The processor 802 may further include a hardware chip. The hardware chip may be an application-specific integrated circuit (application-specific integrated circuit, ASIC), a programmable logic device (programmable logic device, PLD), or a combination thereof. The PLD may be a complex programmable logic device (complex programmable logic device, CPLD), a field-programmable gate array (field-programmable gate array, FPGA), generic array logic (generic array logic, GAL), or any combination thereof.

[0073] The memory 801 may include a volatile memory (volatile memory), for example, a random access memory (random-access memory, RAM). Alternatively, the memory 801 may include a non-volatile memory (non-volatile memory), for example, a flash memory (flash memory), a hard disk drive (hard disk drive, HDD), or a solid-state drive (solid-state drive, SSD). Alternatively, the memory 801 may include a combination of the foregoing types of memories.

[0074] Based on an inventive idea the same as that of the encoding method shown in FIG. 3, as shown in FIG. 7, an embodiment of this application further provides a schematic structural diagram of an embodiment of an encoding apparatus. The apparatus may include: a first encoding module 901, an interleaving module 902, and a second encoding module 903. The first encoding module 901 is configured to perform cyclic redundancy check CRC encoding on A to-be-encoded information bits based on a CRC polynomial, to obtain a first bit sequence, where the first bit sequence includes L CRC bits and A information bits, L and A are positive integers, $L=11$, and the CRC polynomial is any one of the following polynomials:

$$\begin{aligned} & D^{11}+D^{10}+D^9+D^5+1; \\ & D^{11}+D^7+D^6+D^2+1; \\ & D^{11}+D^{10}+D^9+D^6+D^4+D^2+1; \\ & D^{11}+D^{10}+D^9+D^7+D^5+D+1; \\ & D^{11}+D^9+D^8+D^6+D^5+D+1; \end{aligned}$$

$$D^{11}+D^{10}+D^9+D^8+D^7+D^5+D^4+D+1;$$

$$D^{11}+D^{10}+D^3+D+1;$$

$$D^{11}+D^5+D^3+D+1;$$

$$D^{11}+D^{10}+D^9+D^8+D^6+D^5+D^3+D+1;$$
5
$$D^{11}+D^{10}+D^8+D^7+D^6+D^5+D^3+D+1;$$

$$D^{11}+D^9+D^7+D^6+D^5+D^4+D^3+D+1;$$

$$D^{11}+D^{10}+D^9+D^7+D^6+D^3+D^2+D+1; \text{ or}$$

$$D^{11}+D^8+D^6+D^5+D^4+D^3+D^2+D+1.$$

[0075] Usually, the CRC polynomial used for CRC encoding is implemented by using a shift register. The L CRC bits in the first bit sequence may be located after the A to-be-encoded information bits, may be located before the A to-be-encoded information bits, or may be located at any location on which a receive end and a transmit end agree. The interleaving module 902 is an optional module, and is configured to perform an interleaving operation on the first bit sequence, to obtain a second bit sequence. This module is necessary only when a location of an information bit and/or a CRC check bit needs to be adjusted in a manner such as distributed CRC. If the location of the information bit and/or the CRC check bit does not need to be adjusted, this module may be omitted in an actual encoding process, and in this case, the second bit sequence is the first bit sequence. The second encoding module 903 is configured to perform polar encoding on the second bit sequence, and when there is no interleaving module 902, the second encoding module 903 is configured to perform polar encoding on the first bit sequence.

[0076] It should be noted that, modules such as a rate matching module, a modulation module, and a sending module are not drawn in FIG. 7. The sending module is configured to send an encoded sequence, and certainly, before the encoded sequence is sent, operations such as rate matching (if necessary) and modulation further need to be performed.

[0077] Based on an inventive idea the same as the decoding method provided in the foregoing embodiment, as shown in FIG. 8, an embodiment of this application further provides a decoding apparatus 1000. The decoding apparatus 1000 may be configured to perform the decoding method provided in the embodiment of this application, and the decoding apparatus 1000 includes:

an obtaining module 1001, configured to obtain a to-be-decoded bit sequence; and

30 a decoding module 1002, configured to perform a decoding operation on the to-be-decoded bit sequence according to a decoding method, where the decoding method is determined based on a CRC polynomial and a polar encoding method.

[0078] Based on an inventive idea the same as the decoding method provided in the foregoing embodiment, as shown in FIG. 9, an embodiment of this application further provides a decoding

apparatus 1100. The decoding apparatus 1100 is configured to perform the foregoing decoding method. Some or all steps of the foregoing decoding method may be performed by using hardware or by using software. When some or all steps of the foregoing decoding method are performed by using hardware, the decoding apparatus 1100 includes: an input interface 1101, configured to obtain a to-be-decoded bit sequence; a logic circuit 1102, configured to perform the foregoing decoding method; and an output interface 1103, configured to output a decoded sequence.

[0079] Optionally, during specific implementation, the decoding apparatus 1100 may be a chip or an integrated circuit.

[0080] Optionally, when some or all steps of the decoding method of the foregoing embodiment are performed by using software, as shown in FIG. 10, a decoding apparatus 1200 includes: a memory 1201, configured to store a program; and a processor 1202, configured to execute the program stored in the memory 1201. When the program is executed, the decoding apparatus 1200 performs the decoding method provided in the foregoing embodiment.

[0081] Optionally, the memory 1201 may be a physically independent unit, or may be integrated together with the processor 1202.

[0082] Optionally, when some or all steps of the decoding method of the foregoing embodiment are performed by using software, the decoding apparatus 1200 may include only the processor 1202. The memory 1201 configured to store the program is located outside the decoding apparatus 1200, and the processor 1202 is connected to the memory 1201 by using a circuit or a wire, and is configured to read and execute the program stored in the memory 1201.

[0083] The processor 1202 may be a central processing unit (central processing unit, CPU), a network processor (network processor, NP), or a combination of a CPU and an NP.

[0084] The processor 1202 may further include a hardware chip. The hardware chip may be an application-specific integrated circuit (application-specific integrated circuit, ASIC), a programmable logic device (programmable logic device, PLD), or a combination thereof. The PLD may be a complex programmable logic device (complex programmable logic device, CPLD), a field-programmable gate array (field-programmable gate array, FPGA), generic array logic (generic array logic, GAL), or any combination thereof.

[0085] The memory 1201 may include a volatile memory (volatile memory), for example, a random access memory (random-access memory, RAM). Alternatively, the memory 1201 may include a non-volatile memory (non-volatile memory), for example, a flash memory (flash memory), a hard disk drive (hard disk drive, HDD), or a solid-state drive (solid-state drive, SSD). Alternatively, the memory 1201 may include a combination of the foregoing types of memories.

[0086] An embodiment of this application further provides a network device. Referring to FIG.

11, the foregoing encoding apparatus and/or decoding apparatus may be installed in the network device 110. In addition to the foregoing encoding apparatus and decoding apparatus, the network device 110 may further include a transceiver 1302. A bit sequence encoded by the encoding apparatus undergoes subsequent changes or processing and is then sent by the transceiver 1302 to a terminal 112, or the transceiver 1302 is further configured to receive information or data from a terminal 112. The information or data undergoes a series of processing and is converted into a to-be-decoded sequence, and the to-be-decoded sequence is processed by the decoding apparatus to obtain a decoded sequence. The network device 110 may further include a network interface 1304, configured to communicate with another network device.

10 **[0087]** Likewise, the foregoing encoding apparatus and/or decoding apparatus may be configured in the terminal 112. In addition to the foregoing encoding apparatus and/or decoding apparatus, the terminal 112 may further include a transceiver 1312. A bit sequence encoded by the encoding apparatus undergoes subsequent changes or processing (including but not limited to some or all of rate matching, modulation, digital-to-analog conversion, and frequency conversion) and is then sent 15 by the transceiver 1312 to the network device 110, or the transceiver 1312 is further configured to receive information or data from the network device 110. The information or data undergoes a series of processing (including but not limited to some or all of frequency conversion, analog-to-digital conversion, demodulation, and rate de-matching) and is converted into a to-be-decoded sequence, and the to-be-decoded sequence is processed by the decoding apparatus to obtain a decoded sequence. 20 The terminal 112 may further include a user input/output interface 1314, configured to receive information entered by a user. Information that needs to be sent to the network device 110 needs to be processed by an encoder and then sent by the transceiver 1312 to the network device 110. After undergoing subsequent processing, data decoded by a decoder may be presented to the user by using the input/output interface 1314.

25 **[0088]** An embodiment of this application further provides a computer storage medium that stores a computer program. The computer program is used to perform the encoding method shown in FIG. 3 and the foregoing embodiment and the decoding method provided in the foregoing embodiment.

[0089] An embodiment of this application further provides a polar encoding apparatus, including any one of the encoding apparatuses in FIG. 5 to FIG. 7 and any one of the decoding apparatuses in 30 FIG. 8 to FIG. 10.

[0090] An embodiment of this application further provides a computer program product including an instruction. When the instruction runs on a computer, the computer performs the encoding method shown in FIG. 3 and the decoding method provided in the foregoing embodiment.

[0091] Persons skilled in the art should understand that the embodiments of this application may

be provided as a method, a system, or a computer program product. Therefore, this application may use a form of hardware only embodiments, software only embodiments, or embodiments with a combination of software and hardware. Moreover, this application may use a form of a computer program product that is implemented on one or more computer-usable storage media (including but not limited to a disk memory, a CD-ROM, and an optical memory) that include computer-usable program code.

[0092] This application is described with reference to the flowcharts and/or block diagrams of the method, the device (system), and the computer program product according to the embodiments of this application. It should be understood that computer program instructions may be used to implement each process and/or each block in the flowcharts and/or the block diagrams and a combination of a process and/or a block in the flowcharts and/or the block diagrams. These computer program instructions may be provided for a general-purpose computer, a dedicated computer, an embedded processor, or a processor of any other programmable data processing device to generate a machine, so that the instructions executed by a computer or a processor of any other programmable data processing device generate an apparatus for implementing a specific function in one or more processes in the flowcharts and/or in one or more blocks in the block diagrams.

[0093] These computer program instructions may be stored in a computer readable memory that can instruct the computer or any other programmable data processing device to work in a specific manner, so that the instructions stored in the computer readable memory generate an artifact that includes an instruction apparatus. The instruction apparatus implements a specific function in one or more processes in the flowcharts and/or in one or more blocks in the block diagrams.

[0094] These computer program instructions may be loaded onto a computer or another programmable data processing device, so that a series of operations and steps are performed on the computer or the another programmable device, thereby generating computer-implemented processing. Therefore, the instructions executed on the computer or the another programmable device provide steps for implementing a specific function in one or more processes in the flowcharts and/or in one or more blocks in the block diagrams.

[0095] Although some preferred embodiments of this application have been described, persons skilled in the art can make changes and modifications to these embodiments once they learn the basic inventive concept. Therefore, the following claims are intended to be construed as to cover the preferred embodiments and all changes and modifications falling within the scope of this application.

[0096] Obviously, persons skilled in the art can make various modifications and variations to the embodiments of this application without departing from the spirit and scope of the embodiments of this application. This application is intended to cover these modifications and variations provided that

they fall within the scope of protection defined by the following claims and their equivalent technologies.

CLAIMS

What is claimed is:

1. An encoding method, comprising:

5 performing, by a transmit end based on a cyclic redundancy check CRC polynomial, CRC encoding on A to-be-encoded information bits, to obtain a CRC-encoded bit sequence, wherein the CRC-encoded bit sequence comprises L CRC bits and A information bits, L and A are positive integers, $L=11$, and the CRC polynomial is any one of the following polynomials:

$$D^{11}+D^{10}+D^9+D^5+1;$$

$$D^{11}+D^7+D^6+D^2+1;$$

10 $D^{11}+D^{10}+D^9+D^6+D^4+D^2+1;$

$$D^{11}+D^{10}+D^9+D^7+D^5+D+1;$$

$$D^{11}+D^9+D^8+D^6+D^5+D+1;$$

$$D^{11}+D^{10}+D^9+D^8+D^7+D^5+D^4+D+1;$$

$$D^{11}+D^{10}+D^3+D+1;$$

15 $D^{11}+D^5+D^3+D+1;$

$$D^{11}+D^{10}+D^9+D^8+D^6+D^5+D^3+D+1;$$

$$D^{11}+D^{10}+D^8+D^7+D^6+D^5+D^3+D+1;$$

$$D^{11}+D^9+D^7+D^6+D^5+D^4+D^3+D+1;$$

$$D^{11}+D^{10}+D^9+D^7+D^6+D^3+D^2+D+1; \text{ or}$$

20 $D^{11}+D^8+D^6+D^5+D^4+D^3+D^2+D+1; \text{ and}$

performing, by the transmit end, polar encoding on the CRC-encoded bit sequence to obtain a polar-encoded bit sequence.

2. The method according to claim 1, wherein the CRC polynomial is implemented by using a shift register.

25 3. The method according to claim 1 or 2, wherein the L CRC bits in the CRC-encoded bit sequence are located after the A to-be-encoded information bits.

4. The method according to any one of claims 1 to 3, wherein the method further comprises: sending, by the transmit end, the polar-encoded bit sequence.

30 5. The method according to claim 4, wherein before sending the polar-encoded bit sequence, the transmit end performs rate matching on the polar-encoded bit sequence based on a target code length.

6. The method according to any one of claims 1 to 5, wherein the transmit end is a base station or a terminal.

7. An encoding apparatus, comprising:

a first encoding module, configured to perform, based on a cyclic redundancy check CRC

polynomial, CRC encoding on A to-be-encoded information bits, to obtain a CRC-encoded bit sequence, wherein the CRC-encoded bit sequence comprises L CRC bits and A information bits, L and A are positive integers, $L=11$, and the CRC polynomial is any one of the following polynomials:

$$D^{11}+D^{10}+D^9+D^5+1;$$

5 $D^{11}+D^7+D^6+D^2+1;$

$$D^{11}+D^{10}+D^9+D^6+D^4+D^2+1;$$

$$D^{11}+D^{10}+D^9+D^7+D^5+D+1;$$

$$D^{11}+D^9+D^8+D^6+D^5+D+1;$$

$$D^{11}+D^{10}+D^9+D^8+D^7+D^5+D^4+D+1;$$

10 $D^{11}+D^{10}+D^3+D+1;$

$$D^{11}+D^5+D^3+D+1;$$

$$D^{11}+D^{10}+D^9+D^8+D^6+D^5+D^3+D+1;$$

$$D^{11}+D^{10}+D^8+D^7+D^6+D^5+D^3+D+1;$$

$$D^{11}+D^9+D^7+D^6+D^5+D^4+D^3+D+1;$$

15 $D^{11}+D^{10}+D^9+D^7+D^6+D^3+D^2+D+1;$ or

$$D^{11}+D^8+D^6+D^5+D^4+D^3+D^2+D+1;$$
 and

a second encoding module, configured to perform polar encoding on the CRC-encoded bit sequence to obtain a polar-encoded bit sequence.

8. The apparatus according to claim 7, wherein the apparatus further comprises a shift register, and the CRC polynomial is implemented by using the shift register.

9. The apparatus according to claim 7 or 8, wherein the L CRC bits in the CRC-encoded bit sequence are located after the A to-be-encoded information bits.

10. The apparatus according to any one of claims 7 to 9, wherein the apparatus further comprises a sending module, configured to send the polar-encoded bit sequence.

11. The apparatus according to claim 10, wherein before sending the polar-encoded bit sequence, the apparatus performs rate matching on the polar-encoded bit sequence based on a target code length.

12. The apparatus according to any one of claims 7 to 11, wherein the apparatus is a base station or a terminal.

13. An encoding apparatus, comprising a processor, wherein the processor is configured to: perform, based on a cyclic redundancy check CRC polynomial, CRC encoding on A to-be-encoded information bits, to obtain a CRC-encoded bit sequence, wherein the CRC-encoded bit sequence comprises L CRC bits and A information bits, L and A are positive integers, $L=11$, and the CRC polynomial is any one of the following polynomials:

$$D^{11}+D^{10}+D^9+D^5+1;$$

$$D^{11}+D^7+D^6+D^2+1;$$

$$D^{11}+D^{10}+D^9+D^6+D^4+D^2+1;$$

$$D^{11}+D^{10}+D^9+D^7+D^5+D+1;$$

$$D^{11}+D^9+D^8+D^6+D^5+D+1;$$

5 $D^{11}+D^{10}+D^9+D^8+D^7+D^5+D^4+D+1;$

$$D^{11}+D^{10}+D^3+D+1;$$

$$D^{11}+D^5+D^3+D+1;$$

$$D^{11}+D^{10}+D^9+D^8+D^6+D^5+D^3+D+1;$$

$$D^{11}+D^{10}+D^8+D^7+D^6+D^5+D^3+D+1;$$

10 $D^{11}+D^9+D^7+D^6+D^5+D^4+D^3+D+1;$

$$D^{11}+D^{10}+D^9+D^7+D^6+D^3+D^2+D+1; \text{ or}$$

$$D^{11}+D^8+D^6+D^5+D^4+D^3+D^2+D+1; \text{ and}$$

perform polar encoding on the CRC-encoded bit sequence to obtain a polar-encoded bit sequence.

14. The apparatus according to claim 13, wherein the encoding apparatus further comprises a
15 memory, and the memory is configured to store a program instruction.

15. The apparatus according to claim 13 or 14, wherein the CRC polynomial is implemented by
using a shift register.

16. The apparatus according to any one of claims 13 to 15, wherein the L CRC bits in the CRC-
encoded bit sequence are located after the A to-be-encoded information bits.

17. The apparatus according to any one of claims 13 to 16, wherein the apparatus further
20 comprises a transceiver, configured to send the polar-encoded bit sequence.

18. The apparatus according to claim 17, wherein before the transceiver sends the polar-encoded
bit sequence, the processor is further configured to perform rate matching on the polar-encoded bit
sequence based on a target code length.

19. The apparatus according to any one of claims 13 to 18, wherein the apparatus is a base station
25 or a terminal.

20. An encoding apparatus, comprising:

an input interface, configured to obtain A to-be-encoded information bits;

a logic circuit, configured to: perform, based on a cyclic redundancy check CRC polynomial,
30 CRC encoding on the A to-be-encoded information bits, to obtain a CRC-encoded bit sequence,
wherein the CRC-encoded bit sequence comprises L CRC bits and A information bits, L and A are
positive integers, $L=11$, and the CRC polynomial is any one of the following polynomials:

$$D^{11}+D^{10}+D^9+D^5+1;$$

$$D^{11}+D^7+D^6+D^2+1;$$

$$D^{11}+D^{10}+D^9+D^6+D^4+D^2+1;$$

$$D^{11}+D^{10}+D^9+D^7+D^5+D+1;$$

$$D^{11}+D^9+D^8+D^6+D^5+D+1;$$

$$D^{11}+D^{10}+D^9+D^8+D^7+D^5+D^4+D+1;$$

5 $D^{11}+D^{10}+D^3+D+1;$

$$D^{11}+D^5+D^3+D+1;$$

$$D^{11}+D^{10}+D^9+D^8+D^6+D^5+D^3+D+1;$$

$$D^{11}+D^{10}+D^8+D^7+D^6+D^5+D^3+D+1;$$

$$D^{11}+D^9+D^7+D^6+D^5+D^4+D^3+D+1;$$

10 $D^{11}+D^{10}+D^9+D^7+D^6+D^3+D^2+D+1;$ or

$$D^{11}+D^8+D^6+D^5+D^4+D^3+D^2+D+1;$$
 and

perform polar encoding on the CRC-encoded bit sequence to obtain a polar-encoded bit sequence;

and

an output interface, configured to output the polar-encoded bit sequence.

15 21. The apparatus according to claim 20, wherein the CRC polynomial is implemented by using a shift register.

22. The apparatus according to claim 20 or 21, wherein the L CRC bits in the CRC-encoded bit sequence are located after the A to-be-encoded information bits.

20 23. The apparatus according to claim 20, wherein the logic circuit is further configured to: before the output interface outputs the polar-encoded bit sequence, perform rate matching on the polar-encoded bit sequence based on a target code length.

24. A computer readable storage medium, wherein the storage medium is configured to store a computer program, and when run by a communications device used as a transmit end, the computer program is used to perform the method according to any one of claims 1 to 5.

25 25. A computer program product, wherein when run by a communications device used as a transmit end, the computer program is used to perform the method according to any one of claims 1 to 5.

26. A decoding method, comprising:

receiving, by a receive end, a to-be-decoded sequence;

30 performing, by the receive end, polar decoding on the to-be-decoded sequence based on a CRC polynomial, to obtain a polar-decoded bit sequence, wherein the polar-decoded bit sequence comprises L CRC bits and A information bits, L and A are positive integers, $L=11$, and the CRC polynomial is any one of the following polynomials:

$$D^{11}+D^{10}+D^9+D^5+1;$$

$$D^{11}+D^7+D^6+D^2+1;$$

$$D^{11}+D^{10}+D^9+D^6+D^4+D^2+1;$$

$$D^{11}+D^{10}+D^9+D^7+D^5+D+1;$$

$$D^{11}+D^9+D^8+D^6+D^5+D+1;$$

5 $D^{11}+D^{10}+D^9+D^8+D^7+D^5+D^4+D+1;$

$$D^{11}+D^{10}+D^3+D+1;$$

$$D^{11}+D^5+D^3+D+1;$$

$$D^{11}+D^{10}+D^9+D^8+D^6+D^5+D^3+D+1;$$

$$D^{11}+D^{10}+D^8+D^7+D^6+D^5+D^3+D+1;$$

10 $D^{11}+D^9+D^7+D^6+D^5+D^4+D^3+D+1;$

$$D^{11}+D^{10}+D^9+D^7+D^6+D^3+D^2+D+1; \text{ or}$$

$$D^{11}+D^8+D^6+D^5+D^4+D^3+D^2+D+1; \text{ and}$$

outputting, by the receive end, the polar-decoded bit sequence.

15 27. The method according to claim 26, wherein the L CRC bits in the to-be-decoded sequence are located after the A to-be-encoded information bits.

28. The method according to claim 26 or 27, wherein before the receive end receives the to-be-decoded sequence, the receive end is further configured to receive information or data from a transmit end and perform rate de-matching on the information or data from the transmit end, to obtain the to-be-decoded sequence.

20 29. The method according to any one of claims 26 to 28, wherein the receive end is a base station or a terminal.

30. A decoding apparatus, comprising:

an obtaining module, configured to obtain a to-be-decoded bit sequence, wherein the to-be-decoded bit sequence comprises L CRC bits and A information bits, L and A are positive integers, and
25 $L=11$; and

a decoding module, configured to perform polar decoding on the to-be-decoded sequence based on the CRC polynomial, to obtain a polar-decoded bit sequence, wherein the CRC polynomial is any one of the following polynomials:

$$D^{11}+D^{10}+D^9+D^5+1;$$

30 $D^{11}+D^7+D^6+D^2+1;$

$$D^{11}+D^{10}+D^9+D^6+D^4+D^2+1;$$

$$D^{11}+D^{10}+D^9+D^7+D^5+D+1;$$

$$D^{11}+D^9+D^8+D^6+D^5+D+1;$$

$$D^{11}+D^{10}+D^9+D^8+D^7+D^5+D^4+D+1;$$

$D^{11}+D^{10}+D^3+D+1;$
 $D^{11}+D^5+D^3+D+1;$
 $D^{11}+D^{10}+D^9+D^8+D^6+D^5+D^3+D+1;$
 $D^{11}+D^{10}+D^8+D^7+D^6+D^5+D^3+D+1;$
5 $D^{11}+D^9+D^7+D^6+D^5+D^4+D^3+D+1;$
 $D^{11}+D^{10}+D^9+D^7+D^6+D^3+D^2+D+1;$ or
 $D^{11}+D^8+D^6+D^5+D^4+D^3+D^2+D+1.$

31. The apparatus according to claim 30, wherein the L CRC bits in the to-be-decoded sequence are located after the A to-be-encoded information bits.

10 32. The apparatus according to claim 30 or 31, wherein the apparatus is a base station or a terminal.

33. A decoding apparatus, comprising a processor, wherein the processor is configured to:
obtain a to-be-decoded bit sequence, wherein the to-be-decoded bit sequence comprises L CRC bits and A information bits, and $L=11$; and

15 perform polar decoding on the to-be-decoded sequence based on a CRC polynomial, to obtain a polar-decoded bit sequence, wherein the CRC polynomial is any one of the following polynomials:

$D^{11}+D^{10}+D^9+D^5+1;$
 $D^{11}+D^7+D^6+D^2+1;$
 $D^{11}+D^{10}+D^9+D^6+D^4+D^2+1;$
20 $D^{11}+D^{10}+D^9+D^7+D^5+D+1;$
 $D^{11}+D^9+D^8+D^6+D^5+D+1;$
 $D^{11}+D^{10}+D^9+D^8+D^7+D^5+D^4+D+1;$
 $D^{11}+D^{10}+D^3+D+1;$
 $D^{11}+D^5+D^3+D+1;$
25 $D^{11}+D^{10}+D^9+D^8+D^6+D^5+D^3+D+1;$
 $D^{11}+D^{10}+D^8+D^7+D^6+D^5+D^3+D+1;$
 $D^{11}+D^9+D^7+D^6+D^5+D^4+D^3+D+1;$
 $D^{11}+D^{10}+D^9+D^7+D^6+D^3+D^2+D+1;$ or
 $D^{11}+D^8+D^6+D^5+D^4+D^3+D^2+D+1.$

30 34. The apparatus according to claim 33, wherein the decoding apparatus further comprises a memory, and the memory is configured to store a program instruction.

35. The apparatus according to claim 33 or 34, wherein the L CRC bits in the to-be-decoded sequence are located after the A to-be-encoded information bits.

36. The apparatus according to any one of claims 33 to 35, wherein before the processor receives

the to-be-decoded bit sequence, the processor is further configured to receive information or data from a transmit end and perform rate de-matching on the information or data from the transmit end, to obtain the to-be-decoded sequence.

5 37. The apparatus according to any one of claims 33 to 36, wherein the apparatus is a base station or a terminal.

38. A decoding apparatus, comprising:

an input interface, configured to obtain a to-be-decoded sequence;

10 a logic circuit, configured to perform polar decoding on the to-be-decoded sequence based on a CRC polynomial, to obtain a polar-decoded bit sequence, wherein the polar-decoded bit sequence comprises L CRC bits and A information bits, L and A are positive integers, $L=11$, and the CRC polynomial is any one of the following polynomials:

$$D^{11}+D^{10}+D^9+D^5+1;$$

$$D^{11}+D^7+D^6+D^2+1;$$

$$D^{11}+D^{10}+D^9+D^6+D^4+D^2+1;$$

15 $D^{11}+D^{10}+D^9+D^7+D^5+D+1;$

$$D^{11}+D^9+D^8+D^6+D^5+D+1;$$

$$D^{11}+D^{10}+D^9+D^8+D^7+D^5+D^4+D+1;$$

$$D^{11}+D^{10}+D^3+D+1;$$

$$D^{11}+D^5+D^3+D+1;$$

20 $D^{11}+D^{10}+D^9+D^8+D^6+D^5+D^3+D+1;$

$$D^{11}+D^{10}+D^8+D^7+D^6+D^5+D^3+D+1;$$

$$D^{11}+D^9+D^7+D^6+D^5+D^4+D^3+D+1;$$

$$D^{11}+D^{10}+D^9+D^7+D^6+D^3+D^2+D+1; \text{ or}$$

$$D^{11}+D^8+D^6+D^5+D^4+D^3+D^2+D+1; \text{ and}$$

25 an output interface, configured to output the polar-decoded bit sequence.

39. The apparatus according to claim 38, wherein the L CRC bits in the to-be-decoded sequence are located after the A to-be-encoded information bits.

40. A computer readable storage medium, wherein the storage medium is configured to store a computer program, and when run by a communications device used as a receive end, the computer
30 program is used to perform the method according to any one of claims 26 to 28.

41. A computer program product, wherein the computer program product comprises a computer program, and when run by a communications device used as a receive end, the computer program is used to perform the method according to any one of claims 26 to 28.

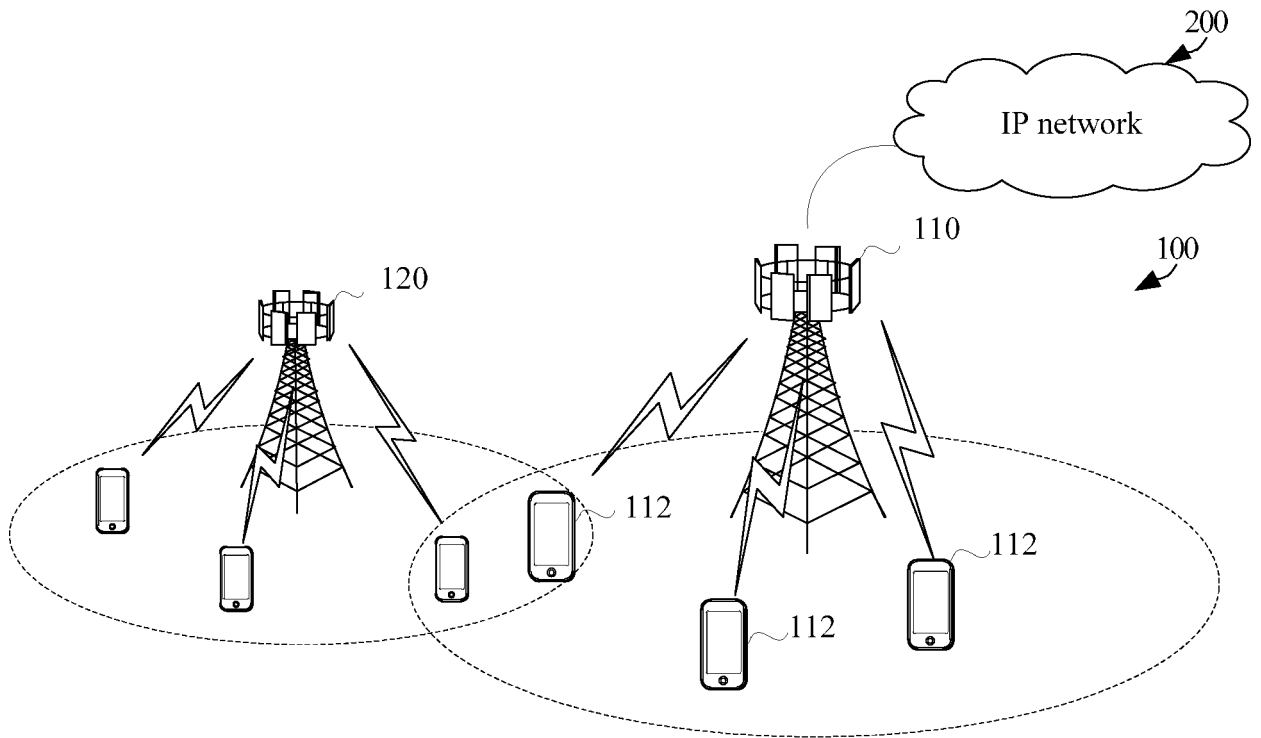

FIG. 1 (a)

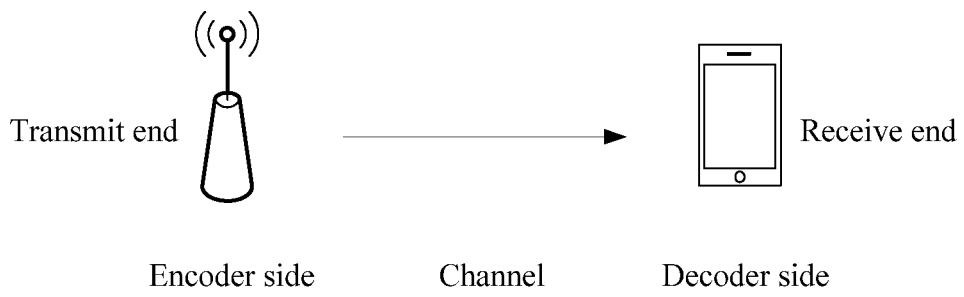

FIG. 1 (b)

2/6

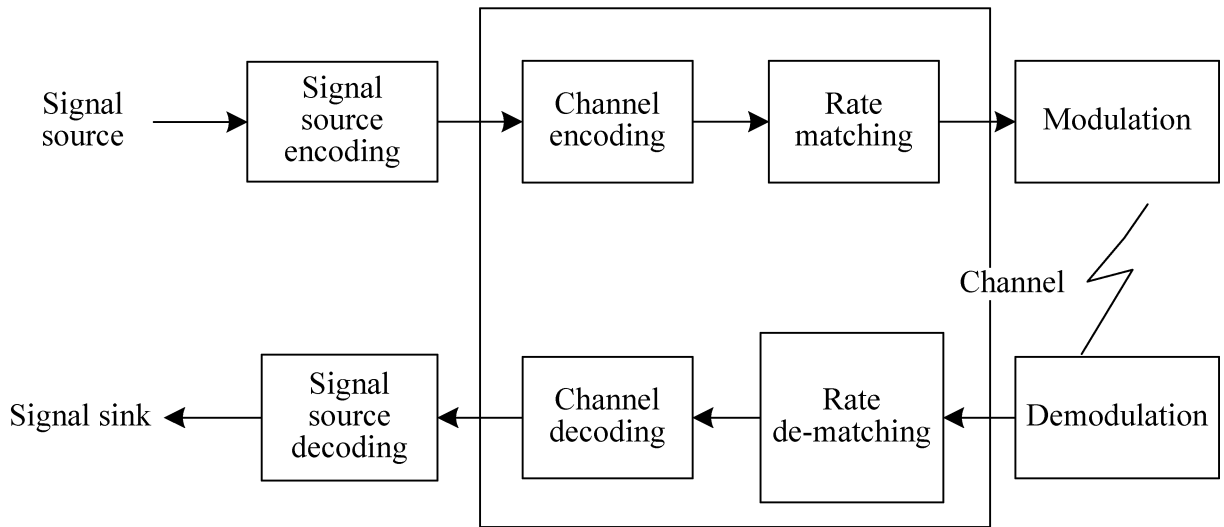

FIG. 2

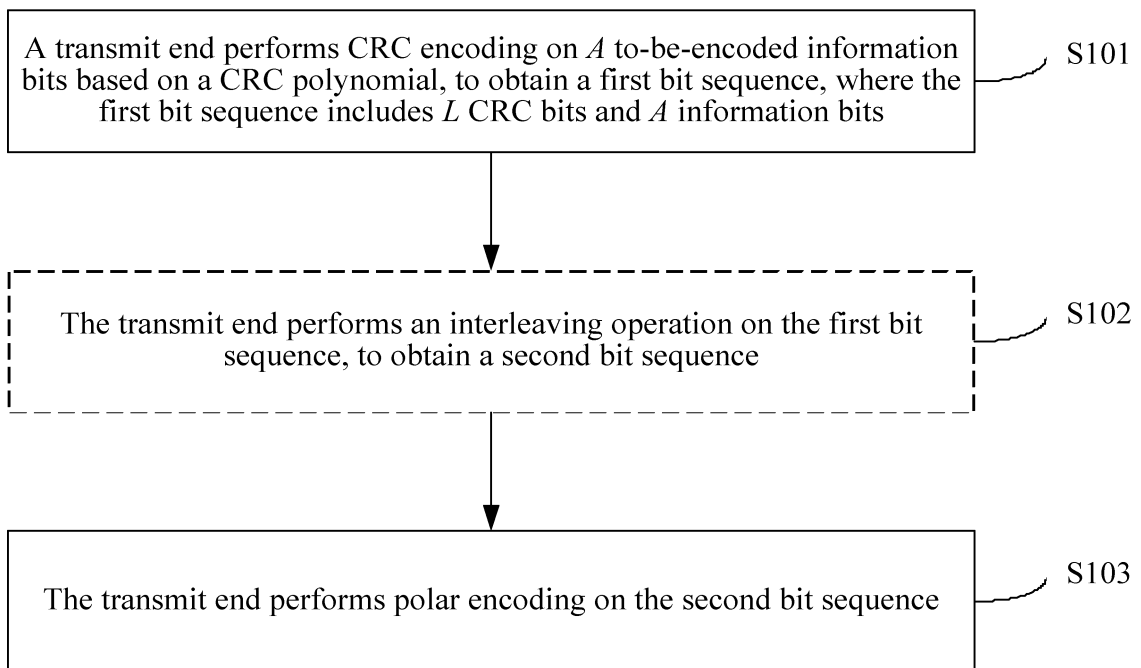

FIG. 3

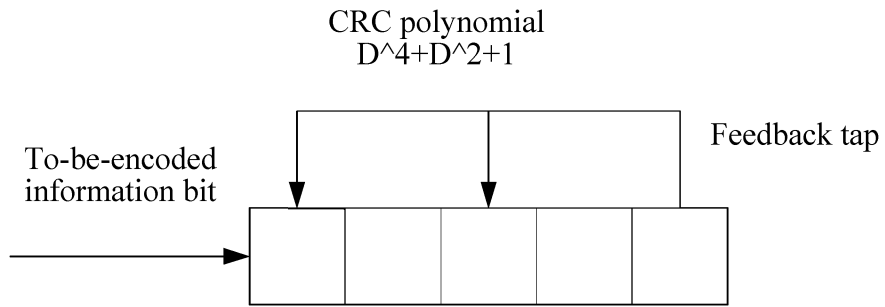

FIG. 4

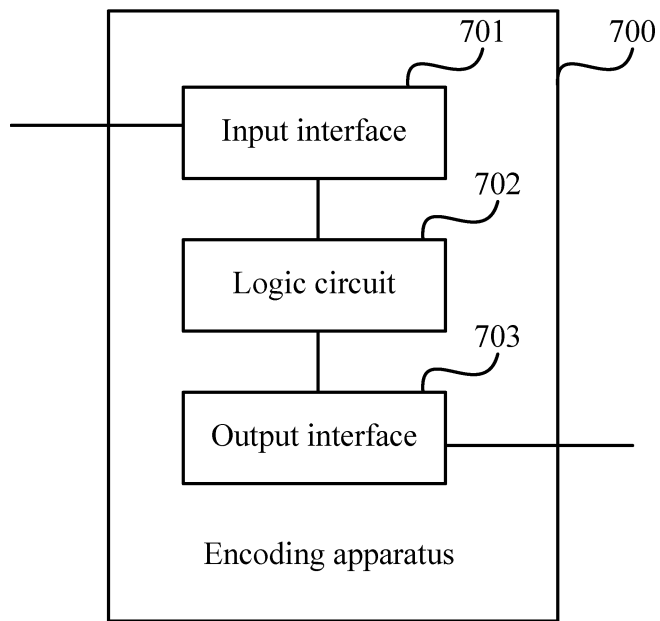

FIG. 5

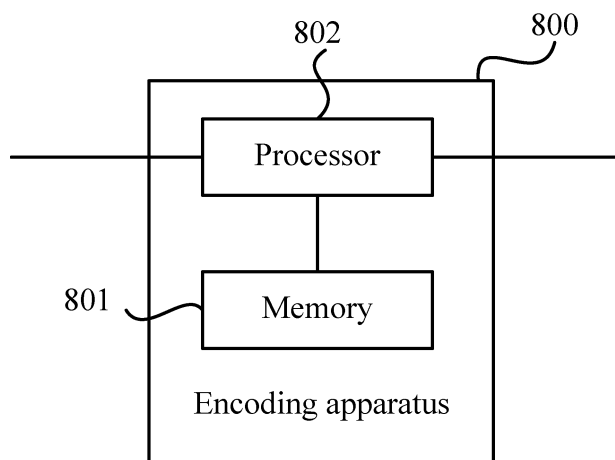

FIG. 6

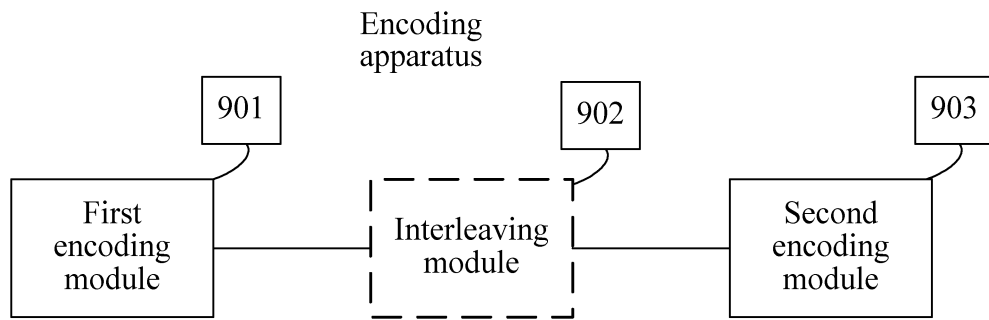

FIG. 7

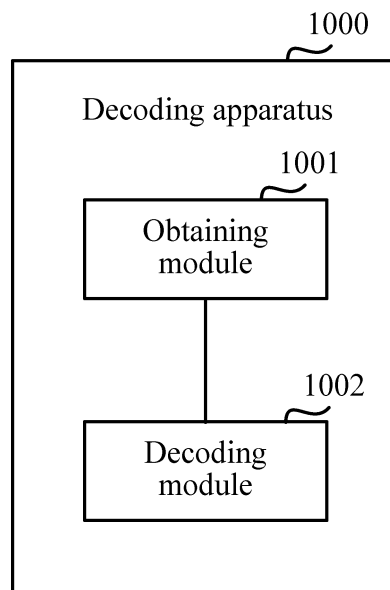

FIG. 8

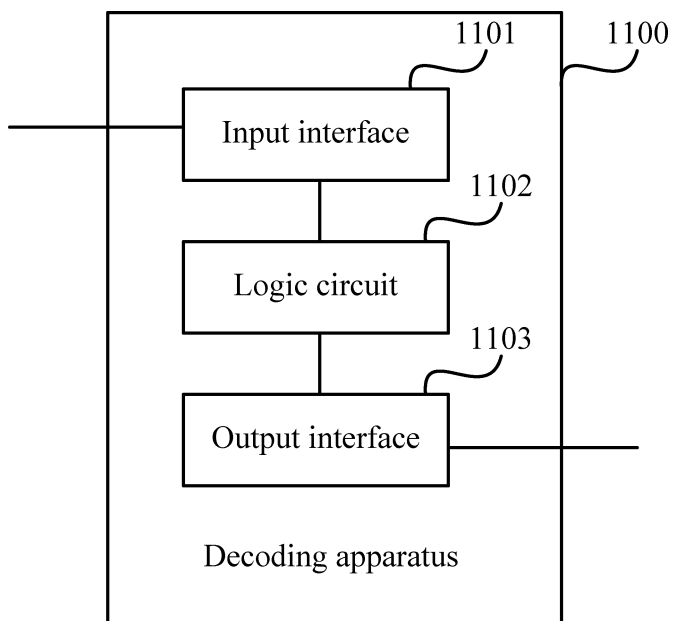

FIG. 9

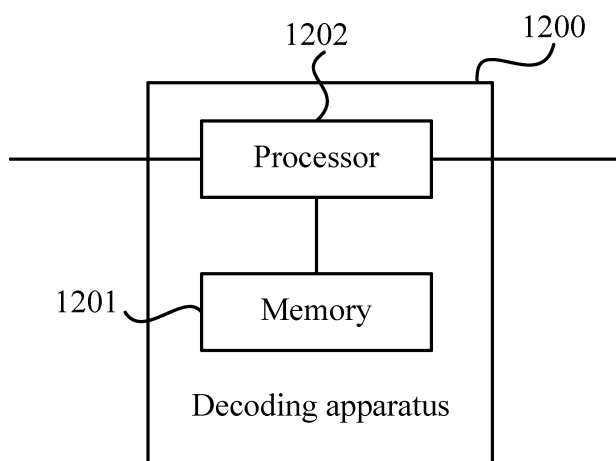

FIG. 10

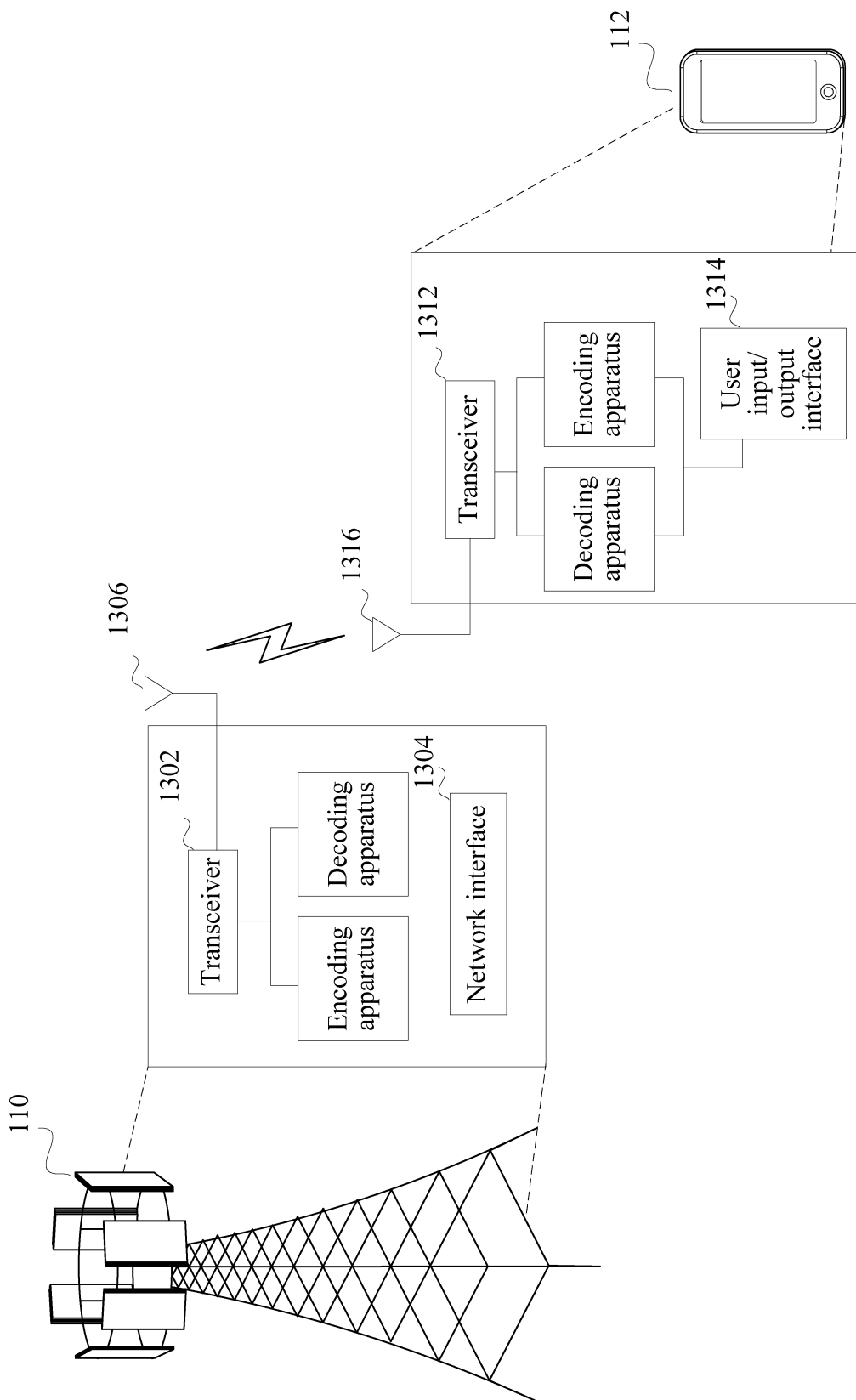

FIG. 11