

G. W. SMITH.
 SEDIMENT RECEIVING AND DRAWING OFF DEVICE FOR TANKS.
 APPLICATION FILED JAN. 22, 1921.

1,383,433.

Patented July 5, 1921.

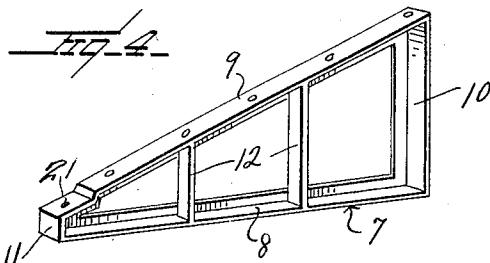
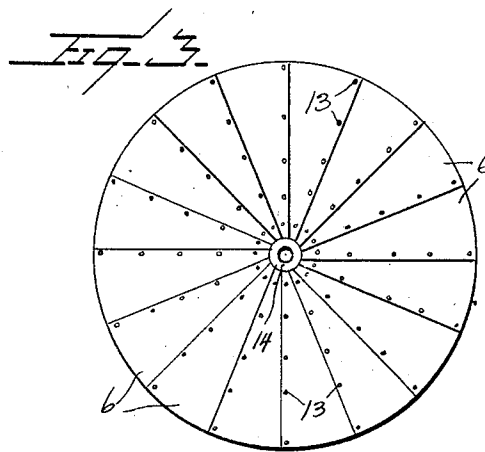
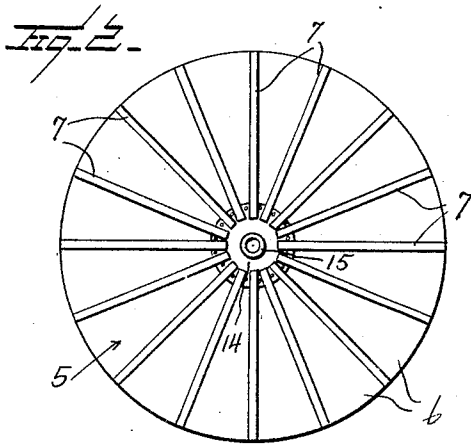
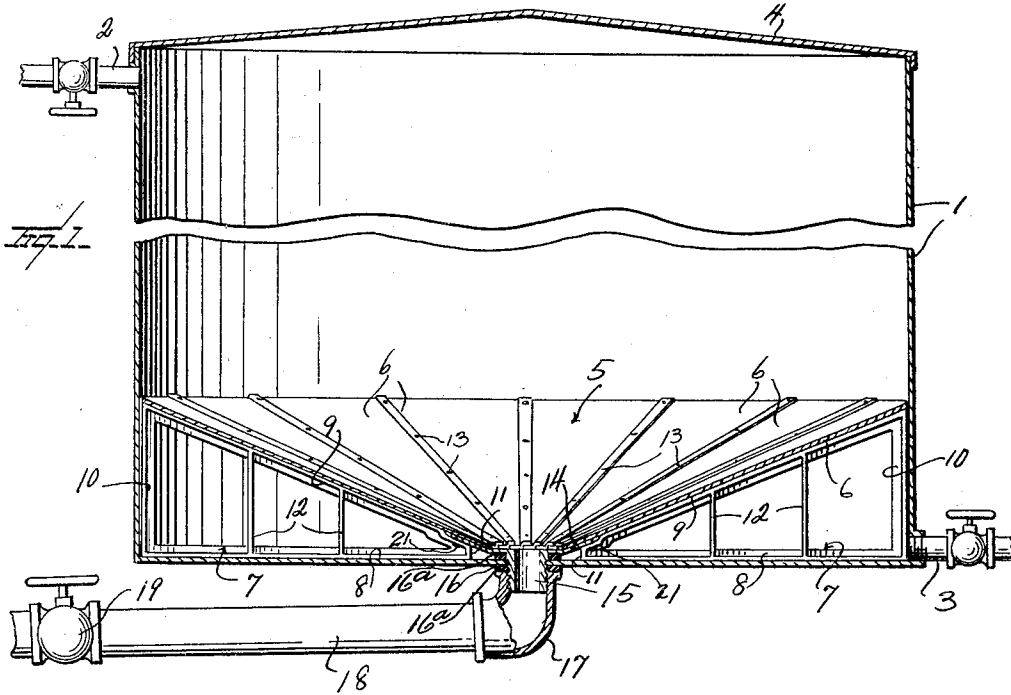

Inventor

G. W. Smith

By *Watson E. Coleman*
 Attorney

UNITED STATES PATENT OFFICE.

GEORGE W. SMITH, OF GARBER, OKLAHOMA.

SEDIMENT RECEIVING AND DRAWING-OFF DEVICE FOR TANKS.

1,383,433.

Specification of Letters Patent.

Patented July 5, 1921.

Application filed January 22, 1921. Serial No. 439,221.

To all whom it may concern:

Be it known that I, GEORGE W. SMITH, a citizen of the United States, residing at Garber, in the county of Garfield and State of Oklahoma, have invented certain new and useful Improvements in Sediment Receiving and Drawing-Off Devices for Tanks, of which the following is a specification, reference being had to the accompanying drawings.

It is the purpose of the present invention to provide a sediment or refuse receiving and drawing off device for gasolene and other tanks, constructed to fit within the tank adjacent the bottom thereof and of conical form, so that the refuse, sediment or settlings may deposit thereon, and at intervals, either while the tank is filled, or when empty the sediment may be drawn off, thereby removing substantially all the foreign matter and leaving a clean supply of gasolene.

Another purpose embodies the provision of a device of this kind comprising a plurality of triangular frames resting upon the bottom of the tank and connected to a plurality of segments, which constitute the conical container thereby supporting the bottom of the container or sediment receiving device spaced in the bottom of the tank, so that the clean or clear fluid can be drawn off from the bottom of the sediment receiving pan.

A still further purpose is the provision of means for fastening the tapered ends of the sections of the receiving pan together at the apex thereof, and having means whereby a refuse or sediment pipe may be connected to the pan or sediment receiving container, whereby the sediment or refuse can be drawn off at any time, by opening a valve, which is carried by the pipe.

While the design and construction at present illustrated and set forth is deemed preferable, it is obvious that as a result of a reduction of the invention to a more practical form for commercial purposes, the invention may be susceptible of changes, and the right to these changes is claimed, provided they are comprehended within the scope of what is claimed.

The invention comprises further features and combination of parts, as will be hereinafter set forth, shown in the drawings and claimed.

In the drawings:—

Figure 1 is a view in section of a gasolene tank, showing the improved sediment or refuse receiving container or pan as resting on the bottom thereof, and illustrating the discharge pipe for the refuse or sediment.

Fig. 2 is a bottom plan view of the sediment receiving device or container.

Fig. 3 is a top plan view.

Fig. 4 is a detail view of one of the radial frames for the bottom of the container or pan.

Referring more especially to the drawings, 1 designates a gasolene tank constructed of wood, metal or the like, and which is provided with an intake pipe 2 and drawing off pipe 3, there being a conventional form of closure 4 for the tank.

The improved sediment container or receiving pan 5 is mounted upon the bottom of the tank, and this pan or container comprises a plurality of segments 6.

In order to fasten the segments together, and to insure a rigid construction, a plurality of frames 7 are provided. Each frame 7 is substantially triangular in contour, and comprises the lower radial bar 8, the relatively wide inclined bar 9, which is braced relatively to the bar 8, with the end uprights 10 and 11. Suitable braces 12 connect the horizontal bar 8 and the inclined bar 9, thereby reinforcing the frame, and insuring rigidity.

These substantially triangular frames are located adjacent the joints of the segments 6 of the container or pan, there being bolts or the like 13 passing through the overlapping parts of the segments and through the bars 9 of the frames, for rigidly connecting the parts. Where the segments join at points adjacent the bars 9 of the frames, the edge portions of the segments are overlapped. In other words the adjacent edges of the segments are overlapped, and the bolts pass through the overlapped portions, and also through the bars 9.

When the pan or container is made up in this manner consisting of the segments, it is obvious that a pan or container will be produced having a conical form or contour, in other words conically dished, so that the sediment and refuse will eventually pass to the center of the pan or container, so that it can be drawn off easily. A conical plate 14 is bolted or otherwise secured to the tapered

ends of the segments, in order to hold the segments relatively rigid, as well as rigid with relation to the frames. This conical plate 14 connects the threaded extension 5 15, which passes through the opening 16 in the bottom of the tank so that the extension will extend below the tank, there being suitable gaskets or washers 16^a on the extension to insure a tight connection. In order to 10 connect the drain or drawing off pipe to the container or pan, an elbow 17 is threaded to the extension 15, and to which the drawing off or drain pipe 18 is connected. The drawing off or drain pipe 18 may be dis- 15 posed in any suitable position, preferably slightly inclined, so that the sediment or refuse may easily pass out through the pipe. However, before attaching the pipe 18 se- 20 curely and permanently to the elbow, the elbow which is engaged with the drain or drawing off pipe, is first rotated in order to bind one end edge of the elbow against one of the gaskets 16^a, thereby insuring a 25 perfectly tight joint of the parts. The arrangement and construction of the container being such and the conical bottom of a diam- 30 eter, as to provide an infinite space between the edge of the conical bottom and the edges of the uprights 10 of the frames 7, as to permit the clear gasolene to pass beneath the conical false bottom, so that it can be drawn off easily.

The draining or drawing off pipe 18 has a suitable valve 19, which may be opened 35 for the purpose of permitting the refuse or sediment to pass out.

In the use of the device, the tank in which the container or pan is located receives the gasolene, the same entering the tank through 40 the pipe 2. After the gasolene or other fluid thoroughly settles in the tank, the settlings, refuse or sediment will finally settle upon the pan or container. It has been found that the sediment or settlings will 45 eventually find their way to the center of the pan or container, where they can be easily drawn off, while the gasolene will flow under the container, and that portion of the gasolene under the container is practically 50 clear, and in this case, by turning on the valve of the pipe 3, pure clear gasolene may be drawn off. After the gasolene settles, the sediment having been collected in the center of the conical false bottom, the valve of the 55 drawing off pipe 3 may be opened, allowing the gasolene to pass through the infinite space between the edge of the false bottom and the inner circumference of the wall of the tank, leaving the sediment or refuse in 60 the false bottom. In fact a certain amount of sediment may collect at the edge of the false bottom where it is infinitely spaced from the inner circumference of the tank, and through which the gasolene will strain, 65 hence the gasolene which passes through said

infinite space will be very clear. As the gasolene diminishes, further supply of gasolene may be allowed to enter through the pipe 2. In fastening the conical plate 14 to the inner tapered ends of the segments, 70 it is the aim to also fasten the plate to the triangle frames, as indicated at 21.

The invention having been set forth, what is claimed as being useful is:

1. A sediment or refuse pan, comprising 75 a conical false bottom for a fluid tank, radial frames engaging the bottom of the tank and supporting the false bottom, and a drawing off pipe passing through and connected to the bottom of the tank and to the false 80 bottom, whereby the refuse or sediment may be easily and quickly removed.

2. In a device for the purpose indicated, the combination with a fluid containing tank, of a conical false bottom adjacent the bot- 85 tom of the tank and having its edge spaced infinitesimally from the inner surface of the wall of the tank, a refuse drawing off pipe connected to the false bottom whereby the 90 sediment may be drawn off, fluid drawing off means connected to the side of the tank at a point below the false bottom, whereby a clear fluid may be drawn off leaving the sediment or refuse settling upon the false 95 bottom.

3. In a device for the purpose indicated, the combination with a fluid containing tank, of a conical false bottom adjacent the bot- 100 tom of the tank and having its edge in contact with the inner surface of the wall of the tank, a refuse drawing off pipe connected to the false bottom whereby the sedi- 105 ment may be drawn off, fluid drawing off means connected to the side of the tank at a point below the false bottom, whereby a clear fluid may be drawn off leaving the sediment or refuse settling upon the false 110 bottom, said false bottom comprising a plurality of segments, and a plurality of substantially triangular frames connected to the segments where the segments unite.

4. In a device for the purpose indicated, the combination with a fluid containing tank, of a conical false bottom adjacent the bot- 115 tom of the tank and having its edge in contact with the inner surface of the wall of the tank, a refuse drawing off pipe connected to the false bottom whereby the sedi- 120 ment may be drawn off, fluid drawing off means connected to the side of the tank at a point below the false bottom, whereby a clear fluid may be drawn off leaving the sedi- 125 ment or refuse settling upon the false bottom, said false bottom comprising a plurality of segments, and a plurality of substantially triangular frames connected to the segments where the segments unite, and means comprising a coupling conical plate for connecting the refuse drawing off means 130 to the apex of the false bottom.

5. In a device for the purpose indicated, a fluid containing tank, a sediment collector comprising a conical false bottom disposed in the bottom of the tank with its edge infinitely spaced from the inner surface of the tank, a sediment drawing off means passing through the bottom of the tank and connected to the false bottom, and a fluid drawing off means connected to the side of the tank at a point below the edge of the false bottom, whereby clear fluid may be drawn off leaving the sediment settlings upon the false bottom.

6. In a device for the purpose indicated, a fluid containing tank, a sediment collector comprising a conical false bottom disposed

in the bottom of the tank with its edge infinitely spaced from the inner surface of the tank, a sediment drawing off means passing through the bottom of the tank and connected to the false bottom, and a fluid drawing off means connected to the side of the tank at a point below the edge of the false bottom, whereby clear fluid may be drawn off leaving the sediment settlings upon the false bottom, and frames radially disposed between the bottom of the tank and the false bottom for supporting the latter.

In testimony whereof I hereunto affix my signature.

GEORGE W. SMITH.