

Nov. 24, 1959

F. J. SCHULTE

2,914,110

INVALID HANDLING APPARATUS

Filed Jan. 6, 1956

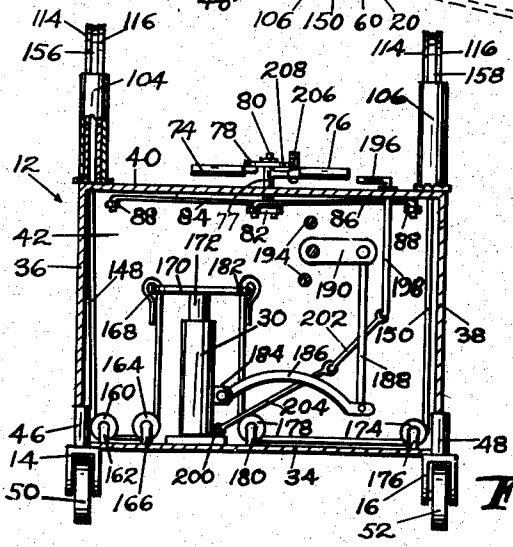
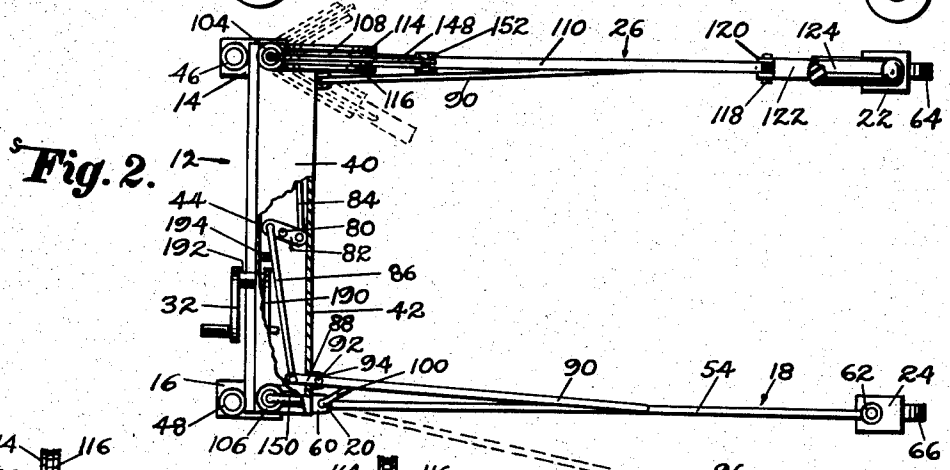
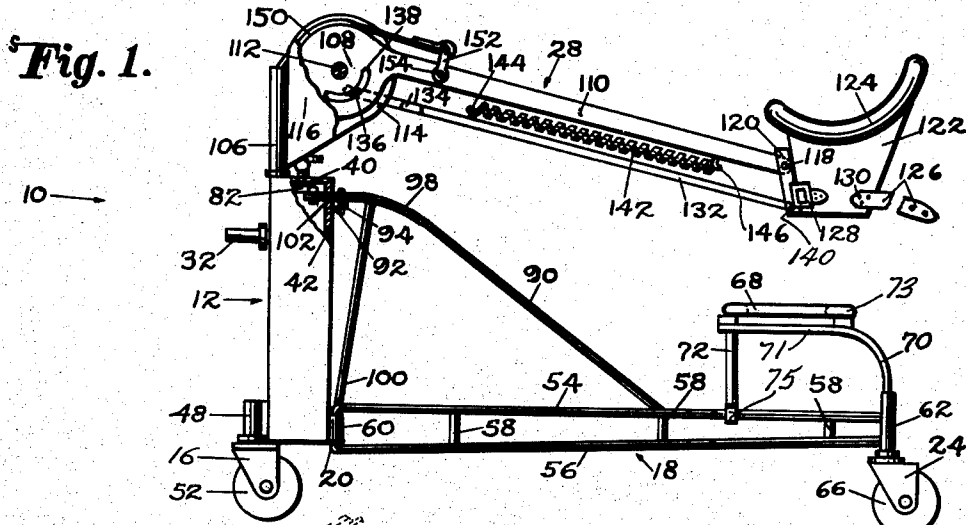

INVENTOR.
F. J. Schulte
BY *Arthur H. Sturges*
Attorney

1

2,914,110

INVALID HANDLING APPARATUS

Frederick J. Schulte, Harvard, Nebr.

Application January 6, 1956, Serial No. 557,750

5 Claims. (Cl. 155—28)

This invention relates to the care of invalids and particularly devices for transporting invalids from one position to another, and in particular a head including a vertically disposed control box mounted on casters and having rearwardly extended legs with casters on extended ends thereof pivotally mounted on the lower end, and hydraulically actuated arms with arm rests on extended ends pivotally mounted on the upper end and adapted to extend over the legs.

The purpose of this invention is to provide an invalid transporting device in which lifting elements thereof are hydraulically actuated so that a comparatively small nurse or attendant may elevate a relatively heavy patient.

Various types of devices have been provided for assisting invalids in moving from one place to another such as to or from a bed or to a library, sun porch, dining room, or the like, however, particularly when the patient is heavy more than one person is required to move the patient to or from the transporting device. Furthermore, in numerous instances, it is difficult to raise parts of the body of a patient without causing pain.

With these thoughts in mind this invention contemplates a transporting device wherein hydraulically actuated pivotally mounted arms are adapted to swing laterally and also vertically so that one of the arms may be moved to a position at one side of a bed to assist a patient being moved from the bed, and wherein with the arms used as crutch elements the patient may be comfortably conveyed from place to place by a single operator.

The object of this invention is, therefore, to provide an invalid handling and conveying device in which an invalid may be positioned on the device, conveyed from place to place, and removed from the device by a single operator.

Another object of the invention is to provide a frame for carrying invalids from place to place in which elevating elements of the device are hydraulically actuated making it possible for an individual attendant to shift a patient from one position to another.

Another important object is to provide an invalid carrier having arms and legs extended from a head in which both the arms and legs are adjustable laterally and the arms are adjustable vertically.

It is yet another object of the invention to provide an invalid handling device with which an invalid may be comfortably elevated from a sitting to a standing position by actuating a hand crank.

A further object of the invention is to provide a carrier for invalids and aged persons in which the individuals are supported by crutch elements nested in the arm pits and in which the crutch elements with the individual therein are adapted to be elevated by hydraulic means actuated by a single attendant.

A still further object is to provide a handling device for invalids and aged persons in which elevating elements of the device are mechanically operated and in which the device is of a simple and economical construction.

With these and other objects and advantages in view

2

the invention embodies a rectangular-shaped control box providing a head, casters pivotally mounted on the lower end of the control box and positioned at the sides thereof, horizontally disposed legs having casters on extended ends pivotally mounted on the lower end of the control box, arms having armpit receiving elements on extended ends pivotally mounted on the upper end of the control box and adapted to swing laterally and vertically, and a hydraulic jack connected to the arms by cables for raising and lowering the arms.

Other features and advantages of the invention will appear from the following description taken in connection with the drawings, wherein:

Figure 1 is a side elevational view of the improved invalid handling apparatus showing the arms in partly elevated positions and with parts broken away.

Figure 2 is a plan view of the device with the arm and part of the control box on one side of the apparatus broken away to more clearly show the leg below and with one of the arms and also one of the legs shown in laterally disposed positions in dotted lines.

Figure 3 is a cross section through the control box showing the hydraulic cylinder with the connecting cables and control elements thereof.

While one embodiment of the invention is illustrated in the above-referred-to drawings, it is to be understood that they are merely for the purpose of illustration, and that various changes in construction may be resorted to in the course of manufacture in order that the invention may be utilized to the best advantage according to circumstances which may arise, without in any manner departing from the spirit and intention of the device, which is to be limited only in accordance with the appended claims. And while there is stated the primary field of utility of the invention, it remains obvious that it may be employed in any other capacity wherein it may be found applicable.

In the accompanying drawings, and in the following specification, the same reference characters are used to designate the same parts and elements throughout, and in which the numeral 10 refers to the invention in its entirety, numeral 12 indicating a control box mounted on casters 14 and 16, numeral 18 legs pivotally mounted by pins 20 on the rear of the control box and having casters 22 and 24 on extended ends, numerals 26 and 28 arms pivotally mounted on the upper end of the control box, and numeral 30 is a hydraulic cylinder adapted to be actuated by a hand crank 32.

The control box is provided with a base 34, end walls 36 and 38, an upper panel 40, a back 42, and a front wall or cover 44. The front wall is provided with bearings 46 and 48 in which the casters 14 and 16 are pivotally mounted, and, as shown in Figure 3, the casters are provided with wheels 50 and 52.

The legs 18 are formed with tubular upper rails 54 and similar lower rails 56 and the rails are reinforced with struts 58. The forward ends of the legs 18 are mounted by the pins 20 in bearings 60 on the back of the control box 12. The extended ends of the legs are provided with vertically disposed tubular bearings 62 in which the casters 22 and 24, which are provided with rollers 64 and 66, are pivotally mounted. A seat 68 is provided and the seat extends between the upper rails 54 with the legs in the positions shown in full lines in Figure 2, and the seat is supported by brackets having arcuate bars 70 and posts 72, as shown in Figure 1. The seat is suitably attached to horizontal portions 71 of the bars 70 and the vertical sections of the bars 70 extend into upper ends of the bearings 62, whereby with forks 75 on the lower ends of the posts 72 straddling the rails 54 the seat is supported in an upright position.

The lateral movements of the legs are controlled by

3

handles 74 and 76, the handle 74 extending from a disc 78 on the upper end of a shaft 80, which is pivotally mounted in the upper panel 40 of the control box, and on the lower end of which a bar 82 is positioned. The handle 76 is stationary, being secured to a sleeve 77 on the panel 40 and in which the shaft 80 is rotatably mounted, and, as shown in Figure 3, the handle 76 is provided with a pin 206 that coacts with notches 208 in the disc 78 to retain the handle 74 and legs 18 in adjusted positions. The bar 82 is connected by links 84 and 86 to arms 88 extended from upper ends of diagonal braces 90, the lower ends of which are secured, such as by welding, to upper surfaces of the upper rails 54 of the legs, and the upper ends being pivotally mounted by pins 92 in bearings 94 on the rear wall or back 42 of the control box. By this means the legs are moved laterally, as indicated by the dotted lines 96, in Figure 2 of the drawing, as the handle 74 is actuated. The upper ends of the braces 90 are provided with arcuate sections 98 and the upper ends are supported by struts 100 the lower ends of which are secured, such as by welding to the upper rails 54. The arms 88 of the braces 90 extend through openings 102 in the back of the control box.

The arms 26 and 28 are mounted with open tubular bearings 104 and 106 on the upper end of the control box with hubs 108 on the ends of bars 110 pivotally mounted by pins 112 between spaced plates 114 and 116 extended from the bearings, and the extended ends of the bars 110 are pivotally connected by pins 118 to U-shaped elements 120 on the ends of blocks 122 on the upper surfaces of which crutch shoes or cushions 124 are positioned. The cushions 124, which provide arm rests, are adapted to nest in the armpits of a patient and the arms may be retained in the cushions by straps 126 having buckles 128 thereon. The straps are secured to the blocks by fasteners, as indicated by the numeral 130.

The blocks 122 and arcuate cushions or shoes 124 of the crutch elements are retained in upright positions by the parallelograms of forces provided by the bars 110 and rods 132. The inner ends of the rods 132 are provided with yokes 134 which straddle the hubs 108 and the yokes are adjustably connected to the hubs with pins 136 which extend through arcuate slots 138. The outer ends of the rods are pivotally connected to the U-shaped elements with pins 140. By this means the crutch elements are adapted to be adjusted to suitable angles. The crutch elements are resiliently held upwardly by springs 142, the inner ends of which are connected to the rods 132 with eyes 144 and the outer ends being connected to the bars 110 with eyes 146.

The arms are elevated by cables 148 and 150, the upper ends of which are connected to the bars 110 with shackles 152 which are secured to the bars by bolts 154, and from the shackles the cables extend over the hubs 108, being positioned in grooves 156 and 158, and downwardly through the tubular bearings 104 and 106. From the bearing 104 the cable 148 extends downwardly around a pulley 160 in a stand 162, across to a pulley 164 in a stand 166 and upwardly to one end 168 of an arm 170 on the upper end of the piston rod 172 of the hydraulic jack or cylinder 30. The cable 150 extends downwardly from the bearing 106 to a pulley 174 in a stand 176, from the pulley 174 across to a pulley 178 in a stand 180, and upwardly from the pulley 178 to an end 182 of the arm 170. With the cables connected in this manner upward travel of the piston in the cylinder draws the cables downwardly with the result that the blocks 122 are elevated.

The cylinder 30 is supplied with fluid under pressure by a small pump 184 which is actuated by an arcuate lever 186, the extended end of which is connected by a link 188 to an arm 190 on a shaft 192 on the outer end of which the hand crank 32 is positioned. The parts are actuated with a reciprocating action and the travel of the crank and arm 190 is limited by stops or pins

4

194, as illustrated in Figure 3. The parts are arranged so that the piston is operating in the power stroke when the crank moving downwardly whereby very little effort is required to operate the elevating mechanism. When it is desired to lower the crutch elements the fluid under pressure in the cylinder is released by turning a lever 196 on the upper panel 40 of the control box, the lever being mounted on the upper end of a shaft 198, the lower end of which is connected to a release or return valve 200 with links 202 and 204. The crutch elements may, therefore, be elevated with power and lowered by releasing the power, thereby making it possible for a comparatively small nurse or other attendant to handle patients of all sizes with ease.

Both the arms and legs are adapted to swing laterally and the movement of the legs is controlled by the handle 74 and the stationary handle 76, the handle 74 being secured to the disc 78 and shaft 80 and the handle 76 being mounted on the sleeve 77 on the shaft 80. By this means the handle 74 and disc in combination with the handle 76 and pin 206 provide means for adjusting the positions of the legs, and also means for locking the legs in adjusted positions.

Operation

The improved invalid carrier of this invention is adapted to be rolled to a position at the side of a bed or the like and with one of the crutch elements positioned under the arm of a patient the crutch element may be elevated to comfortably lift the patient until the other crutch element may be inserted under the other arm, and with the arms of the patient positioned in the crutch elements the patient is assisted to a walking position and may readily be moved from one location to another.

When desired, the arms of the patient may be strapped to the crutch elements and by this means the patient may be moved from a bed to a chair, or to the bathroom, or to a position on a sun porch, and returned to the bed by a single attendant.

From the foregoing specification, it will become apparent that the invention disclosed will adequately accomplish the functions for which it has been designed and in an economical manner, and that its simplicity, accuracy, and ease of operation are such as to provide a relatively inexpensive device, considering what it will accomplish, and that it will find an important place in the art to which it appertains when once placed on the market.

It will be seen that the control box is in a sense a vertically extended frame and that the legs 54 provide a means for mounting the vertically extended frames upright with stability. It will be further seen that the crank 32, cylinder 30 and associated mechanism provides a power multiplying device for raising the outer ends of the arms 110.

It is thought that persons skilled in the art to which the invention relates will be able to obtain a clear understanding of the invention after considering the description in connection with the drawings. Therefore, a more lengthy description is regarded as unnecessary.

Changes in shape, size, and rearrangement of details and parts such as come within the purview of the invention claimed may be resorted to in actual practice, if desired.

Having now described the invention that which is claimed to be new and desired to be procured by Letters Patent, is:

1. An invalid carrier comprising a vertically extending frame, wheels pivotally mounted on the lower end of the frame, horizontally positioned legs having wheels on their outer ends and having their inner ends pivotally mounted on the lower part of the frame for lateral swinging, control means on the upper part of the frame for adjusting the positions of the legs laterally, plural arm means including vertically spaced parallel elements and having crutch elements on the outer ends and having their inner

5

ends pivotally mounted on the upper end of the frame and being adapted to swing laterally and vertically, a hydraulic cylinder positioned on the head and operatively connected to said arm means, and manual means for operating the cylinder to vertically adjust the vertical position of the outer ends of said arm means.

2. In an invalid handling apparatus, the combination which comprises a vertically extending frame, wheels upon which the frame is mounted, legs having inner ends pivotally connected to the lower portion of said frame, wheels supporting the outer ends of said legs, handles pivotally mounted on the upper end of said frame and operatively connected to the legs for adjusting the position of the legs laterally, arms including vertically spaced supporting elements pivotally mounted on the upper end of the frame and adapted to swing laterally and vertically, blocks having arcuate cushions providing arm rests on upper edges thereof carried by extended ends of the arms, said arms including parallel bars for retaining the blocks in vertical positions, a hydraulic cylinder mounted on said frame, means operatively connecting the cylinder to the arms for elevating the arms, manual means for supplying fluid under pressure to the cylinder, and means for releasing the fluid to lower the arms.

3. In an invalid handling device, the combination which comprises a vertically extending frame, wheels pivotally mounted on the lower end of the frame, horizontally disposed legs pivotally mounted on the lower part of the frame and adapted to swing laterally, handles mounted on the upper end of the frame, one of said handles being operatively connected to the legs for adjusting the positions of the legs, arms pivotally mounted on the upper end of the frame, said arms including upper bars with rods parallel to the bars and springs connected to the rods and bars, crutch elements including blocks with arcuate cushions on the upper ends thereof carried by the outer ends of said bars and rods, arm retaining straps mounted on the crutch elements, a hydraulic cylinder extended from said frame, an arm carried by a piston rod from said cylinder, cables connected to the bars of the arms mounted on the frame and extending around pulley means to the arm carried by the piston rod, a manually actuated pump for supplying fluid under pressure to the cylinder, and means for releasing the fluid in the cylinder.

4. In the invalid carrier, the combination which comprises a vertically extending frame, horizontally disposed legs pivotally mounted on the lower end of the frame, wheels positioned on the lower ends of the frame and

6

legs, a seat positioned on the outer ends of the legs, hand rails extending from the outer portions of the legs to the upper end of the frame, plural arm means including rods with bars spaced from the rods and parallel thereto pivotally mounted to swing in vertical planes and pivotally mounted to swing in horizontal planes positioned on the upper end of the frame, arm rests carried by the outer ends of the arm means and positioned to coact with the seat on the legs for supporting a patient, a hydraulic cylinder mounted on said frame, and means operatively connecting said hydraulic cylinder to said arm means for raising and lowering said arm means.

5. An invalid carrier comprising a vertically extending frame, wheels upon which the lower end of the frame is mounted, means connected to the lower end of said frame for supporting said frame in an upwardly extending position with stability, arms having inner ends pivotally mounted on an upper part of said frame and adapted to swing vertically about horizontal pivot axes respectively at the inner ends of said arms, arm rests mounted on the outer ends of said arms whereby a patient can be received between said arm rests with his arms hanging over the outer sides thereof, and power multiplying means mounted on said frame for raising and lowering the outer ends of said arms by vertical swinging about said pivot axes whereby when said arms are power-raised with the patient between said arm rests said arm rests exert a lifting force on the patient, and said arms being pivotally mounted on said frame for swinging about vertical axes at the inner ends of said arms whereby patients of differing sizes are accommodated by the variable horizontal spacing of the outer ends of said arms at said arm rests.

References Cited in the file of this patent

UNITED STATES PATENTS

935,170	Smith	Sept. 28, 1909
2,375,907	Farmer	May 15, 1945
2,439,163	Farmer	Apr. 6, 1948
2,539,346	Feist	Jan. 23, 1951
2,565,536	Valentine	Aug. 28, 1951
2,614,267	Perri	Oct. 21, 1952
2,666,930	Lenahan	Jan. 26, 1954
2,747,652	Marsh	May 2, 1956
2,777,667	Stafford et al.	Jan. 15, 1957
2,821,406	Hoyer et al.	Jan. 28, 1958

FOREIGN PATENTS

1,090,552	France	Oct. 20, 1954
-----------	--------	---------------