



US 20050136153A1

(19) **United States**

(12) **Patent Application Publication**

Clark et al.

(10) **Pub. No.: US 2005/0136153 A1**

(43) **Pub. Date: Jun. 23, 2005**

(54) **MOLD APPARATUS AND METHOD**

(52) **U.S. Cl. 425/808**

(76) Inventors: **Rodney L. Clark**, Gurley, AL (US);
John P. Rauseo, Huntsville, AL (US);
Gregg T. Borek, Huntsville, AL (US)

(57) **ABSTRACT**

Correspondence Address:
OLDS, MAIER & RICHARDSON, PLLC
PO BOX 20245
ALEXANDRIA, VA 22320-1245 (US)

A mold apparatus is arranged to produce molded optical elements. The apparatus includes a first mold unit for defining mold cavities and flow passageways, and a second mold unit having a patterned surface for sealing against the first unit. The patterned mold surface may be formed with a plurality of optical patterns, and mold pins may be used to complete the mold cavities. The patterned surface may be formed on a flat metal puck. The puck may be replaced by another puck insert so that the apparatus can be used to produce products having different optical characteristics. Other parts of the apparatus may be changed out to produce molded optical elements of various sizes and shapes. A variety of techniques are described for forming micro-refractive, diffractive and/or other patterns in the metal puck surface.

(21) Appl. No.: **11/046,701**

(22) Filed: **Feb. 1, 2005**

Related U.S. Application Data

(62) Division of application No. 09/347,427, filed on Jul. 6, 1999, now Pat. No. 6,881,358.

Publication Classification

(51) **Int. Cl.⁷ B29D 11/00**

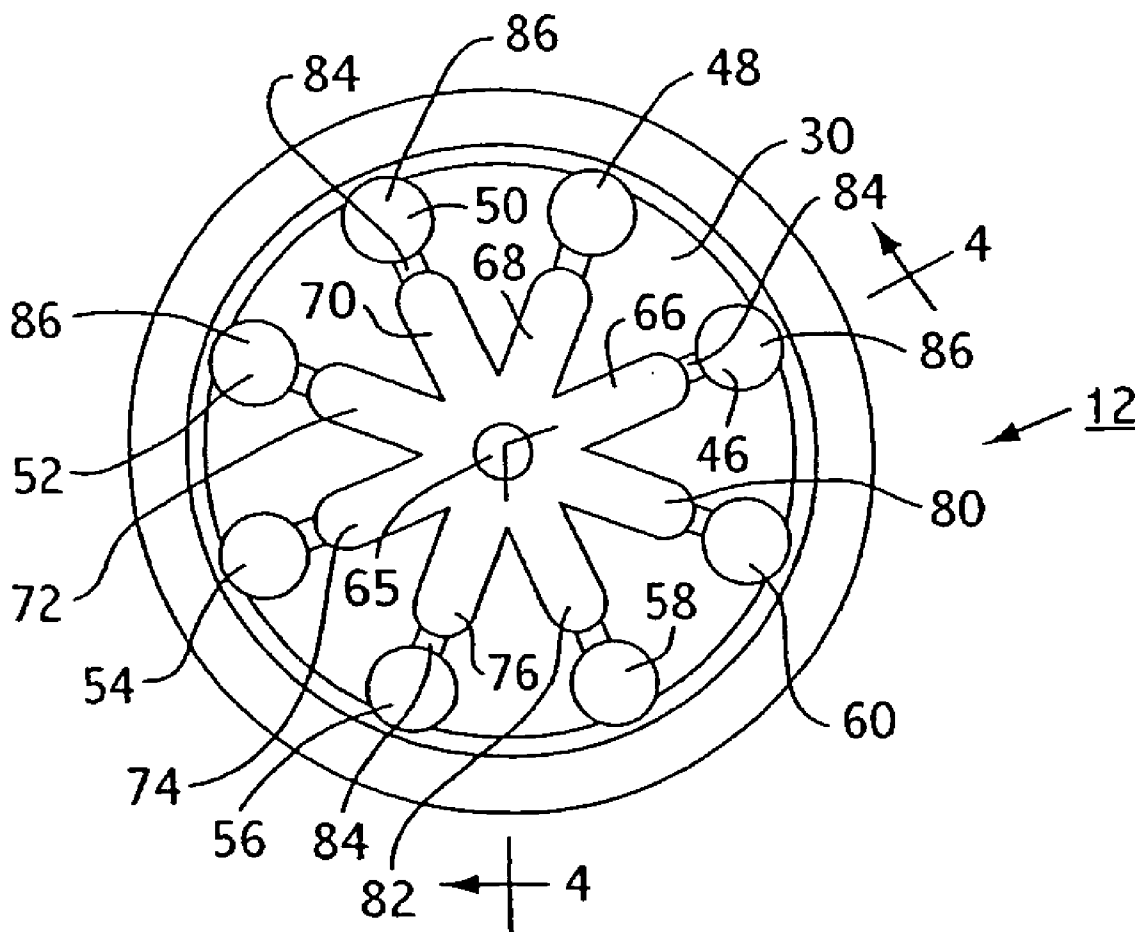

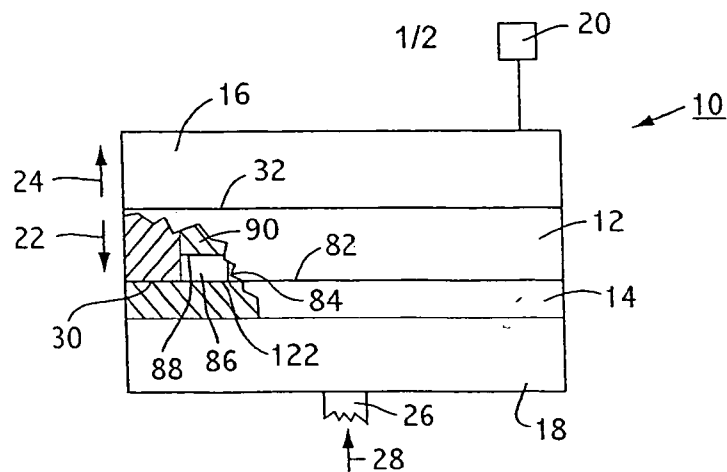

FIG. 1

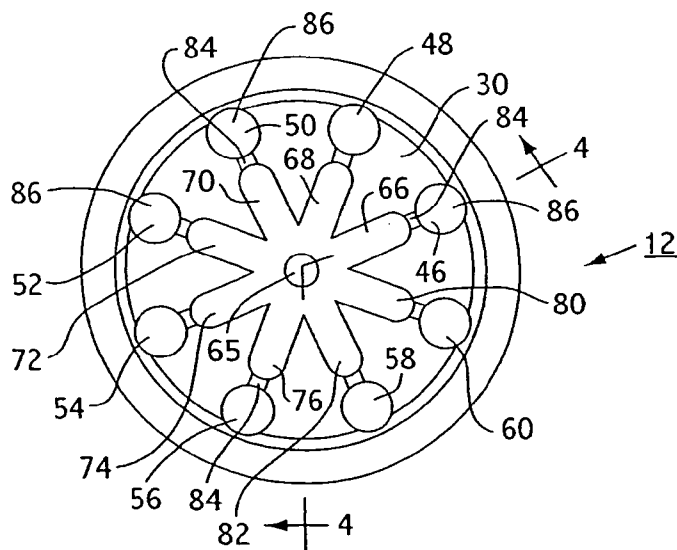

FIG. 2

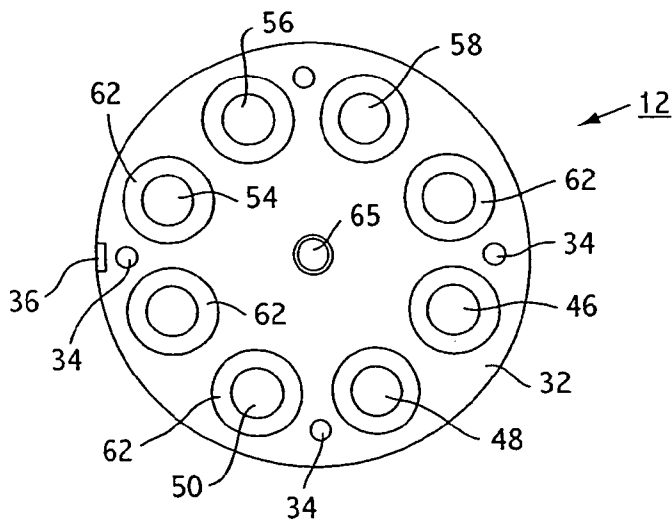

FIG. 3

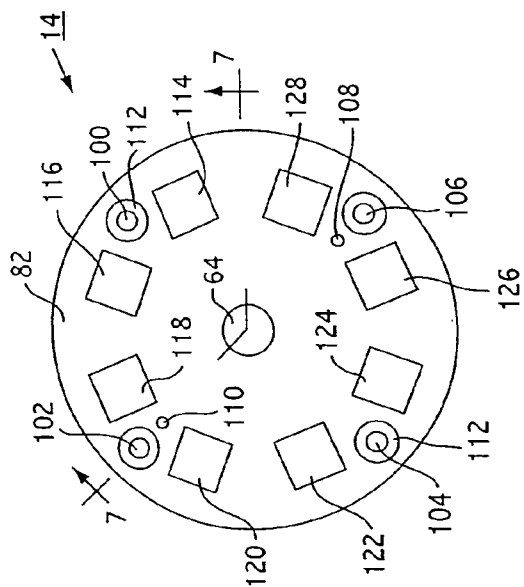

FIG. 6

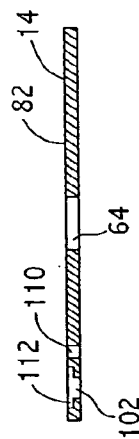

FIG. 7

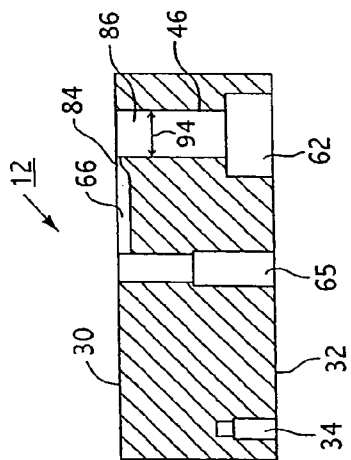

FIG. 4

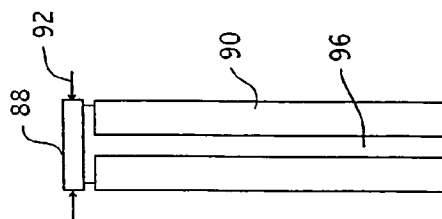

FIG. 5

MOLD APPARATUS AND METHOD

BACKGROUND OF THE INVENTION

[0001] 1. Field of the Invention

[0002] The present invention relates generally to molding systems, including devices, apparatus and methods for producing molded optical elements such as lenses. More particularly, the present invention relates to an injection molding apparatus for forming optically transmissive products with micro-refractive and/or diffractive surfaces.

[0003] 2. Discussion of the Related Art

[0004] It has been suggested to form a mold apparatus by etching diffractive patterns in a flat substrate, cutting the patterns from the substrate, and applying them to mold pins. The pins are used in mold cavities to form molded products with the desired patterns. According to this technique, a separate optical pattern is provided for each mold pin. The technique is disadvantageous because it requires the step of cutting the mold pins from the patterned substrate.

[0005] It has also been suggested to form a mold apparatus with a flat portion and a "stamper" opposed to the flat portion. Audio or video data may be digitally patterned in the stamper by lithography. The stamper is used to define disc-shaped molded products. This approach is disadvantageous because it produces only one product per injection mold cycle. Additional processing steps are required to form multiple products per mold cycle.

SUMMARY OF INVENTION

[0006] The present invention overcomes to a great extent the deficiencies of the prior art. The present invention relates to a mold apparatus for producing molded optical elements. The apparatus includes a first mold unit for defining mold cavities and flow passageways, and a second mold unit having a patterned surface for sealing against the first unit. The patterned mold surface may be formed with a plurality of optical patterns.

[0007] According to another aspect of the invention, mold pins are used to define die mold cavities. The mold pins are located in the first unit so as to be opposed to the optical patterns in the mold surface. According to a preferred embodiment of the invention, the first mold unit has a front face opposed to the mold surface of the second mold unit, and the mold passageways are formed in the front face.

[0008] According to another aspect of the invention, the first mold unit is a removable cutter unit, and the apparatus is arranged to receive other cutter units to produce molded products of different sizes and shapes.

[0009] According to another aspect of the invention, the mold surface is in the form of a metal disc-shaped puck. The metal puck may be removed and replaced by like-shaped metal pucks having different optical mold patterns. The various metal pucks may be readily interchangeable so that the apparatus can be used to produce molded elements having different optical characteristics.

[0010] According to another aspect of the invention, the mold apparatus may be used to form transparent or optically transmissive lenses and other optical elements or devices. The optical elements may have micro-refractive and/or

diffractive patterns molded into first surfaces and planar opposite surfaces. The patterned surfaces may be formed by the metal puck. The planar opposite surfaces may be formed by the mold pins. The molded products may be formed of optical-grade polycarbonate or other suitable materials.

[0011] The present invention also relates to a method of making molded optical elements and devices. In a preferred embodiment of the invention, the method involves an injection molding process. The method may also involve changing or replacing components of the mold apparatus to produce elements of different sizes, shapes and/or optical characteristics.

[0012] The present invention also relates to the production of analog topographic patterns and other patterns on a metal puck for use in a mold apparatus. The patterns may be spaced apart from each other on the otherwise flat surface of the metal puck. According to one aspect of the invention, the metal puck is formed by using an analog gray scale mask to pattern photoresist material. In alternative embodiments of the invention, the patterns are formed by ion milling or electron beam lithography.

[0013] According to the present invention, many molded products may be formed by a single mold apparatus during a single injection cycle. The optical surfaces of the multiple products may be defined by a single patterned puck. There is no need to separate the products from each other after molding. The products may be formed individually and simultaneously within a single apparatus. The same apparatus may be used to produce molded elements of different sizes, shapes and/or optical characteristics by changing out the respective mold surfaces.

[0014] These and other objects and advantages of the invention may be best understood with reference to the following detailed description of preferred embodiments of the invention, the appended claims and the several drawings attached hereto.

BRIEF DESCRIPTION OF THE DRAWINGS

[0015] **FIG. 1** is a partially broken-away side view of a mold apparatus constructed in accordance with a preferred embodiment of the present invention.

[0016] **FIG. 2** is a front view of a cutter unit for the apparatus of **FIG. 1**.

[0017] **FIG. 3** is a rear view of the cutter unit of **FIG. 2**.

[0018] **FIG. 4** is a cross-sectional view of the cutter unit of **FIG. 2**, taken along line 4-4.

[0019] **FIG. 5** is a side view of a cutter pin for the apparatus of **FIG. 1**.

[0020] **FIG. 6** is a front view of a puck for the mold apparatus of **FIG. 1**.

[0021] **FIG. 7** is a cross-sectional view of the puck of **FIG. 6**, taken along line 7-7.

DETAILED DESCRIPTION OF PREFERRED EMBODIMENTS

[0022] Referring now to the drawings, where like reference numerals designate like elements, there is shown in **FIG. 1** a mold apparatus **10** constructed in accordance with

a preferred embodiment of the present invention. The mold apparatus **10** has a cutter unit **12** and a disc-shaped metal puck **14**. The cutter unit **12** may be formed of machined metal or another suitable material. The cutter unit **12** and the puck **14** cooperate to define mold cavities **86** and flow passageways **84** for use in an injection molding process, as described in more detail below. The cutter unit **12** and the puck **14** are removably attached to respective mold units **16**, **18**.

[0023] In the illustrated embodiment, the first mold unit **16** is operated by a suitable operating mechanism **20**. The mechanism **20** may be used to move the mold unit **16** and the cutter unit **12** toward and away from the puck **14** in the directions of arrows **22**, **24**. If desired, the mechanism **20** also may be used to control the positions of cutter pins **90** within the cutter unit **12**, as described in more detail below. The second mold unit **18** may be fixed in place or movable toward and away from the cutter unit **12**. The present invention should not be limited to the specific instrumentalities shown and described in detail herein.

[0024] In operation, the cutter unit **12** is attached to the first mold unit **16** and the puck **14** is attached to the second mold unit **18**. Then the operating mechanism **20** moves the cutter unit **12** into face-to-face sealing contact with the puck **14** to define the mold cavities **86**. Then, molten plastic (not shown) is injected into the apparatus **10** through an inlet conduit **26** in the direction of arrow **28**. The plastic material may be polycarbonate, for example. The plastic fills the mold cavities **86** and solidifies to form diffractive optical elements.

[0025] Then the cutter unit **12** is separated from the puck **14** by the operating mechanism **20**, and the molded products (not shown) are removed from the mold cavities **86**. In a preferred method of operation, the apparatus **10** remains closed until the products are sufficiently solid to be removed from the cutter unit **12** and handled without damage. If desired, a replacement cutter unit and/or a replacement puck (not shown) may be substituted for the original components **12**, **14** to reconfigure the apparatus **10** to form molded optical elements of different sizes and/or different optical characteristics.

[0026] Referring now to FIGS. 2 and 3, the cutter unit **12** has a front face **30** and a back face **32**. The front face **30** is sealed against the puck **14** when the apparatus **10** is in the closed position shown in FIG. 1. The back face **32** of the cutter unit **12** is attached to the first mold unit **16**. Suitable structures, such as threaded openings **34**, are provided for removably connecting the cutter unit **12** to the first mold unit **16**. A notch **36** may be provided for aligning the cutter unit **12** with respect to the apparatus **10** during assembly. If desired, the cutter unit **12** may be removed from the mold unit **16** and replaced with another cutter unit that defines mold cavities **86** of different shapes and/or sizes.

[0027] Mold openings **46**, **48**, **50**, **52**, **54**, **56**, **58**, **60** extend axially through the cutter unit **12**. Each mold opening **46-60** may extend from the front face **30** of the cutter unit **12** to the back face **32**. In the illustrated embodiment, each mold opening **46-60** has the same cylindrical construction. The present invention should not be limited, however, to the specific embodiments shown and described herein. Thus, for example, some of the mold openings may have different diameters than others, and/or some of the openings may be

square or rectangular. If desired, each mold opening **46-60** may be provided with a counter bore **62** (FIG. 3) for accommodating suitable pin-handling equipment as described in more detail below.

[0028] A resin flow passageway **64** (FIG. 6) extends axially through the center of the puck **14**. In addition, radial passageways **66**, **68**, **70**, **72**, **74**, **76**, **78**, **80** (FIG. 2) are formed in the front face **30** of the cutter unit **12**. The radial passageways **66-80** are in fluid communication with the axial passageway **64** when the mold apparatus **10** is in the closed position shown in FIG. 1. In the closed position (FIG. 1), the radial passageways **66-80** are enclosed and sealed by the front face **82** of the puck **14**. In the illustrated embodiment, the enclosed passageways **66-80** have semi-circular cross-sectional configurations.

[0029] During the injection molding process, molten resin flows through the inlet conduit **26**, then through the axial passageway **64**, then through the radial passageways **66-80** (formed between the cutter unit **12** and the puck **14**), and from there into the mold openings **46-60**. Necked-down gate regions **84** may be formed between the radial passageways **66-80** and the respective mold openings **46-60**. The necked-down gate regions **84** have reduced cross-sectional flow areas to facilitate removal of finished products from the associated runner system (scrap). A scrap removal pin (not shown) may be located in an axial opening **65**. The scrap removal pin may be used at the conclusion of the injection molding process to assist in the removal of the runner system from the cutter unit **12**.

[0030] It should be understood that the use of the word "cutter" in the term "cutter unit" does not necessarily mean that the unit **12** performs a cutting function. In the illustrated embodiment, the cutter unit **12** is intended to form the illustrated mold cavities. The cutter unit **12** is not used to cut molded plastic into finished products.

[0031] The mold cavities **86** are formed in the mold openings **46-60**. When the apparatus **10** is in the closed position, the bottom surfaces of the mold cavities **86** are defined by the puck **12**. The puck **12** forms optical patterns in the bottom surfaces of the molded products as described in more detail below. The side walls of the mold cavities **86** (FIG. 4) are defined by the sides of the mold openings **46-60**. In the illustrated embodiment, the mold openings **46-60** have cylindrical side walls. The top surfaces of the mold cavities **86** are defined by the front end faces **88** of suitable mold pins **90** (FIG. 5). A separate mold pin **90** may be provided for each mold opening **46-60**.

[0032] The diameters **92** of the pins **90** may be the same as the internal diameters **94** (FIG. 4) of the mold openings **46-60**. The pins **90** are axially slidable within the mold openings **46-60**. In the illustrated apparatus **10**, there are eight mold cavities **86** and eight pins **90** so that eight optical elements (not shown) can be formed in each injection molding cycle. More or fewer mold cavities may be employed, however. The present invention should not be limited to the specific arrangements shown in the drawings or described herein.

[0033] The front end faces **88** of the mold pins **90** may be smooth or mirrored. In a preferred embodiment of the invention, the end faces **88** are formed of polished metal. The polished faces **88** form corresponding planar surfaces in

the finished products. In an alternative embodiment of the invention, the end faces **88** may be provided with an optical pattern to produce products with patterns on both sides. In other embodiments of the invention, the faces **88** may have curvatures to form molded products with convex or concave surfaces. The thicknesses of the optical elements formed by the apparatus **10** may be defined by the lengths of the pins **90**. If relatively long pins **90** are used, the ends **88** of the pins **90** are located close to the puck **14** to form relatively thin optical products. Shorter pins **90** may be used to form thicker products.

[0034] After the optical elements are formed within the mold cavities **86**, and the cutter unit **12** is moved away from the puck **14**, the pins **90** may be used to push the molded elements out of the cutter unit **12**. The positions and movements of the pins **90** may be controlled by the operating mechanism **20**. The pins **90** are attached to the operating mechanism **20** by suitable means (not shown) which may be received within the counterbores **62**. Suitable slots **96** (FIG. 5) may be provided to prevent rotation of the pins **90** with respect to the actuating mechanism **20** and/or the cutter unit **12**.

[0035] The front face **82** of the puck **14** is shown in FIG. 6. Suitable bolt holes **100**, **102**, **104**, **106** may be used to connect the puck **14** to the second mold unit **18**. In addition, openings **108**, **110** may be arranged to receive alignment pins (not shown) extending from the second mold unit **18** to precisely align the puck **14** within the apparatus **10**. If desired, countersunk portions **112** (FIG. 7) may be machined into the holes **100-106** to receive bolt heads (not shown). This way, the front face **82** of the puck **14** fits flat against the front face **30** of the cutter unit **12** when the puck **14** is mounted in the apparatus **10**.

[0036] According to a preferred embodiment of the invention, micro-refractive or diffractive optical patterns **114**, **116**, **118**, **120**, **122**, **124**, **126**, **128** are formed in the front face **82** of the puck **14**. Each pattern **114-128** is aligned with respect to the mold openings **46-60**. The patterns **114-128** are spaced apart from each other. The patterns **114-128** are formed on only one side of the puck **18**. Except for the patterns **114-128**, the face **82** of the puck **14** may be perfectly flat. Such flatness makes it easier to use lithographic and other techniques to form the desired patterns **114-128**.

[0037] In a preferred embodiment of the invention, the patterns **114-128** are identical to each other, within each puck **12**. Replacement pucks for the apparatus **10** may be provided with different etched patterns to form products with different optical characteristics. The replacement pucks may have the same connection and alignment structure **100-110** so as to be readily installed into the apparatus **10**. In addition, the replacement pucks may have the same arrangement of patterns as the illustrated puck **14** such that the optical patterns in the replacement pucks are aligned with the mold openings **46-60**.

[0038] In operation, the cutter unit **12** is pressed tightly against the face **82** of the puck **14**, causing the individual mold cavities **86** to be defined by the mold openings **46-60**, the front polished ends **88** of the pins **90**, and the puck patterns **114-128**. After the desired number of molded products are formed, the puck **14** may be removed from the second mold unit **18** and replaced with a different puck insert having the same overall configuration but different optical patterns opposed to the mold openings **46-60**.

[0039] Molded products formed by the illustrated apparatus may have planar surfaces on one side formed by the polished end faces **88** of the pins **90** and patterned surfaces on the other side formed by the patterns **114-128** in the puck **14**. The products may be formed of a suitable transparent or optically transmissive material. Thus, the finished products may be used as micro-refractive and/or diffractive lenses. As described in more detail below, the patterns **114-128** may be formed by photolithographic mastering with analog relief patterns.

[0040] The patterns **114-128** may be formed in the puck surface **82** by a variety of lithographic and other techniques, including the techniques disclosed in U.S. patent application Ser. No. 08/788,289, filed Jan. 24, 1997. The entire disclosure of U.S. patent application Ser. No. 08/788,289 is expressly incorporated herein by reference.

[0041] In addition, the patterns **114-128** may be formed by an analog gray scale mask technique, with the puck surface **82** being patterned by ultraviolet (UV) lithography. According to this technique, a metal surface is covered with photoresist. Then an analog gray scale mask is used to pattern the photoresist either by contact printing or by reduction lithography. After the photoresist is patterned, it is developed according to known procedures. The relief pattern on the photoresist is the negative of the desired mold pattern. Then at least three different techniques may be employed to complete the puck **14**.

[0042] In a first completion technique, the patterned photoresist is metalized. The metalized substrate is then inserted into an electroplating bath. A metal surface is grown on the substrate. The process is stopped when the substrate attains the desired thickness. The original substrate is removed and the photoresist is removed. The back side of the patterned and electroformed disc is then polished flat to form the puck **14**.

[0043] In a second completion technique, the patterned photoresist-on-metal structure is placed in an ion milling machine. The ion milling machine transfers the analog pattern in the photoresist directly into the metal material to form the patterned puck **14**.

[0044] In a third completion technique, a non-metallic substrate is etched in a reactive ion etching (RIE) chamber. The etched substrate is then metalized, and then the electroformed product is removed from the non-metallic substrate. The back side of the patterned disc is then polished flat to form the finished puck **14** for the apparatus **10**.

[0045] As an alternative to the analog gray scale mask technique described above, the puck **14** may be formed with an analog profile by a focused ion beam (FIB) apparatus. According to this aspect of the invention, a metal substrate is used without photoresist. The desired refractive or diffractive analog pattern is milled or written directly into the metal material of the puck **14**. The desired patterns **114-128** may be formed either by removal or deposition of metallic material.

[0046] According to yet another method of making the puck **14**, analog profiles may be formed by a direct write technique with electron beam lithography. According to this aspect of the invention, the patterns **114-128** are generated by electron beam lithography with the exposure of the electron beam being controlled at each position to form a

relief pattern in the electron resist. The photoresist is then developed and the resulting patterned substrate is then used to create the puck 14 according to any one of the three completion techniques described above.

[0047] The above description and drawings are only illustrative of preferred embodiments which can achieve and provide the objects, features and advantages of the present invention. It is not intended that the invention be limited to the embodiments shown and described in detail herein. Modifications coming within the spirit and scope of the following claims are to be considered part of the invention.

We claim:

1. A mold apparatus for producing molded optical elements, said apparatus comprising:

a first unit for defining mold cavities and flow passageways; and

a second mold unit having an integrated mold surface for sealing against said first unit, said integrated mold surface containing a plurality of patterns for molding optical patterns in the optical elements; and

wherein said first mold unit is removable, and wherein said apparatus is arranged to receive other first mold units to produce products of different sizes and shapes.

2. A mold apparatus for producing molded optical elements, said apparatus comprising:

a first mold unit for defining a plurality of mold cavities and flow passageways;

a second mold unit having a mold surface for sealing against said first unit, said mold surface containing a corresponding plurality of patterns for molding optical patterns in the optical elements, said optical patterns being located on a single flat metal puck covering the plurality of mold cavities and said flow passageways; and

means for removing said metal puck, such that other pucks may be installed in said apparatus to produce products having different optical characteristics.

3. The apparatus of claim 2, wherein said patterns include micro-refractive patterns.

4. The apparatus of claim 2, wherein said patterns include diffraction patterns.

5. A method for making molded optical elements, said method comprising the steps of:

providing a single metal puck with a plurality of optical patterns;

locating said single metal puck against a mold surface to seal a plurality of mold cavities and flow passageways formed upon said mold surface; and

subsequently, molding optical elements within said mold cavities such that said optical patterns of said single metal puck are formed in said optical elements; and

separating said mold surface from said metal puck, and locating another mold surface against said metal puck to form different size mold cavities.

6. A method for making molded optical elements, said method comprising the steps of:

providing a single metal puck with a plurality of optical patterns;

locating said single metal puck against a mold surface to seal a plurality of mold cavities and flow passageways formed upon said mold surface; and

subsequently, molding optical elements within said mold cavities such that said optical patterns of said single metal puck are formed in said optical elements; and

separating said puck from said mold surface, and providing another metal puck having patterns formed therein to form optical elements having different optical characteristics.

* * * * *