

(No Model.)

W. T. FISHER.
EGG CRATE.

No. 487,144.

Patented Nov. 29, 1892.

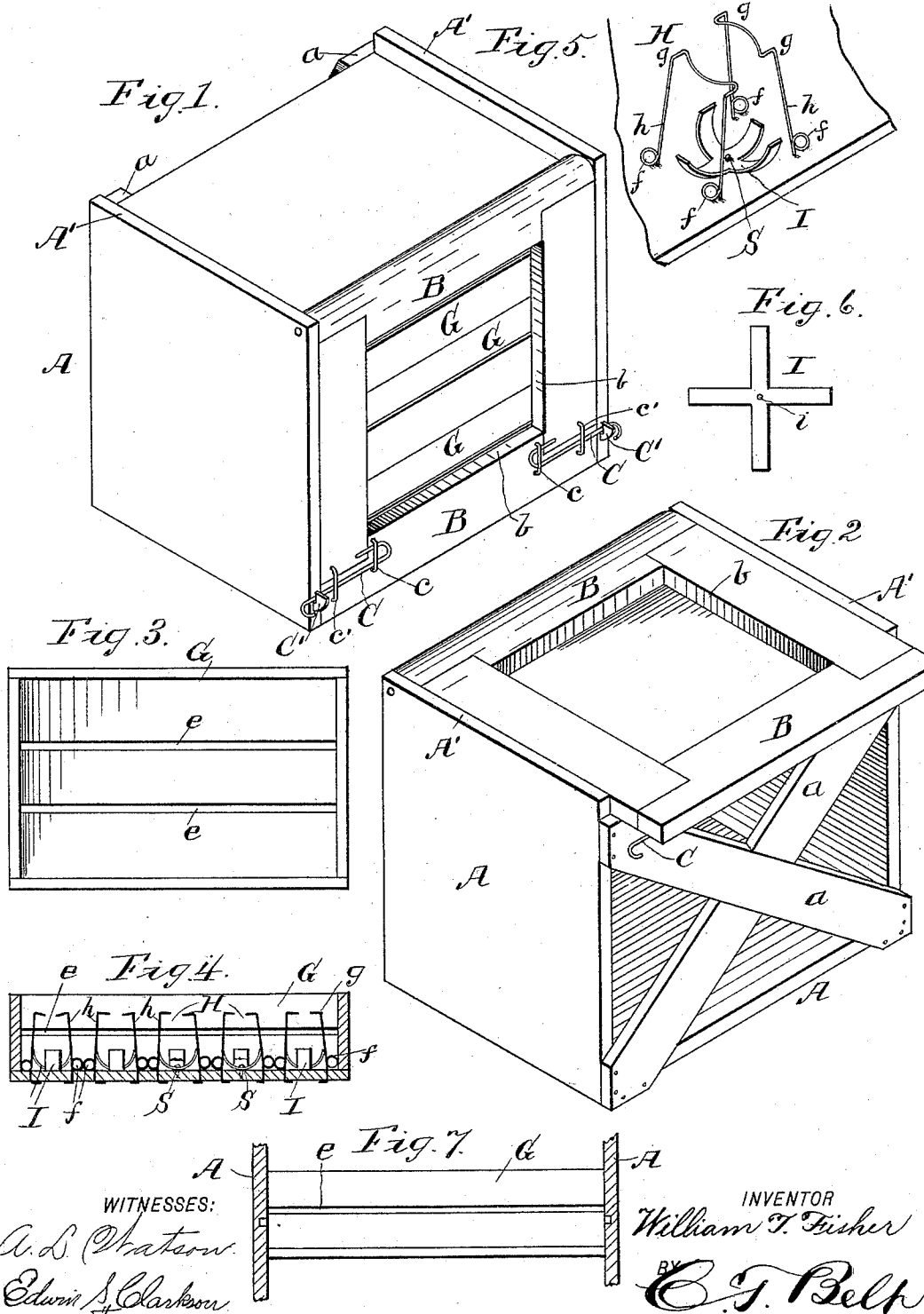

WITNESSES:
A. S. Phatorn.
Edwin S. Clarkson.

INVENTOR
William T. Fisher
 BY
C. J. Bell
 ATTORNEY.

UNITED STATES PATENT OFFICE.

WILLIAM TRIGG FISHER, OF PRIGMORE, TENNESSEE.

EGG-CRATE.

SPECIFICATION forming part of Letters Patent No. 487,144, dated November 29, 1892.

Application filed June 10, 1892. Serial No. 436,224. (No model.)

To all whom it may concern:

Be it known that I, WILLIAM TRIGG FISHER, a citizen of the United States, residing at Prigmore, in the county of McMinn and State of Tennessee, have invented certain new and useful Improvements in Egg-Crates, of which the following is a specification.

This invention relates to egg-crates; and its novelty will be fully understood from the following description and claims when taken in connection with the annexed drawings; and its object is to provide a box for transporting eggs by packing them in a series of combined holders and supports secured to a series of trays or crates contained in said box.

A further object of the invention is to provide a device of great simplicity and cheapness for holding and supporting eggs when packed for shipping.

The invention consists in the novel construction and arrangement of parts, as will be hereinafter fully specified.

In the accompanying drawings, forming part of this specification, Figure 1 is a perspective view of my packing-box with the egg-crates contained therein. Fig. 2 is a similar view taken from the opposite side of the box, as shown in Fig. 1, with the crates removed and its door thrown back on top of the box.

Fig. 3 is a top view of one of the crates. Fig. 4 is a sectional view of one of the crates with the holders and supports secured thereto. Fig. 5 is a perspective view of my egg support and holder. Fig. 6 is a plan view of the support as it is stamped out and before it is bent. Fig. 7 is a modified form of supporting trays in the box.

The same letters of reference denote the same parts throughout the several figures.

The ends, top, and bottom of the packing-box A are solid or entirely closed, while its back is formed by two strips *a*, running diagonally across from the top to the bottom of the box.

The front of the box A is provided with a skeleton door B, pivoted at its top to the ends of the box with an opening *b* left about its middle portion. This opening, as well as the open back, is for the purpose of admitting plenty of air to the interior of the box.

The top edge A' of the ends of the box A project above the top of the box a distance

equal to the thickness of the door B for the purpose of preventing the door moving horizontally after it has been opened on top of the box between the said edges A'.

The top of the box forms a bottom for the opening *b* in the door when it is thrown back, thus furnishing a most convenient receptacle for the eggs as they are removed from or put in the box.

The bottom or free end of the door B is provided with spring-latches C, secured to the door by means of staples *c* and *c'*, and the latches engage a catch C', secured to the front edge of the ends of the box to fasten the door when closed.

The crates, drawers, or trays G have solid ends, while the bottom and sides thereof have ventilating openings or slots *e*, their top being left open. These slots *e* admit air to the eggs for the purpose of preserving them. It will be observed that the crates or trays G set flat upon each other, and that they fit closely together, so as to entirely fill the box, just enough freedom to render them convenient to slide in and out. It will also be observed that the slots *e* in the bottom of the middle crate register with slots in the crates above and below it, whereby ventilation is further insured.

The egg-holder H consists of two pieces of wire *h*, one end of each piece being secured to the crate, having a coil *f* resting upon the inside bottom of the crate. From this coil the wire extends upward nearly the length of an egg, where it is bent at right angles at *g*, then bent horizontally in a semicircular form on the same plane with the right-angle bend, from where it is again bent at right angles and extends down to, is coiled upon, and is secured to the said crate. It will be observed that by thus bending the wire four coils, four uprights, and two semicircular bearings are formed, which semicircular bearings pinch and hold the egg in an upright position in the seat or support I. The seat or support I is formed by stamping it out of sheet metal in one piece and in the shape of a cross having four arms of equal length, and an aperture in its center, through which is passed a rivet S, whereby it is secured to the crate centrally between the four uprights *h* of the holder H. Before or after the support I has been secured

in its place upon the crate the arms thereof are bent upward and inward toward the center of the support to leave an opening at their top somewhat smaller than an egg, so that
 5 when the egg is sprung through the semicircular bearings and down onto the top of the arms they will spring open enough to allow the egg to be seated in the support, and then
 10 pinch and prevent it from moving after it is seated.

Having thus described my invention, what I claim as new, and desire to secure by Letters Patent, is—

1. The combination, with the egg-box, of
 15 the skeleton door pivoted to the ends of the box and adapted to form, with the top of the box, a receptacle when thrown back on top of the said box, substantially as shown and described.

20 2. The combination, with the egg-box and its pivoted skeleton door, of a series of egg-

crates having ventilating-slots which register with each other, a series of egg-holders, such as described, secured to said crates, and a series of spring-supports located within the hold-
 25 ers and secured to the crates, substantially as and for the purpose set forth.

3. The combination, with the egg-box having ends, the top edge of said ends extending above the top surface of the box, of the piv-
 30 oted skeleton door provided with spring-latches, such as shown, the egg-crates having slots and adapted to slide directly upon each other, and the combined egg holder and support secured to the said crates, substantially
 35 as and for the purpose set forth.

In witness whereof I hereunto set my hand in the presence of two witnesses.

WILLIAM TRIGG FISHER.

Witnesses:

T. L. FARRELL,
 J. F. HASE.