

(No Model.)

J. ZERR.

ROLL PAPER HOLDER AND CUTTER.

No. 389,277.

Patented Sept. 11, 1888.

Fig. 1.

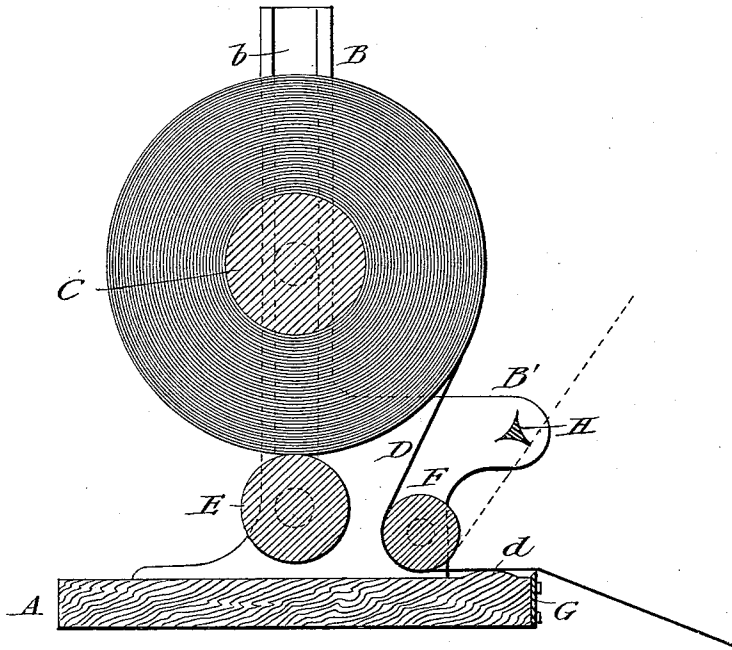
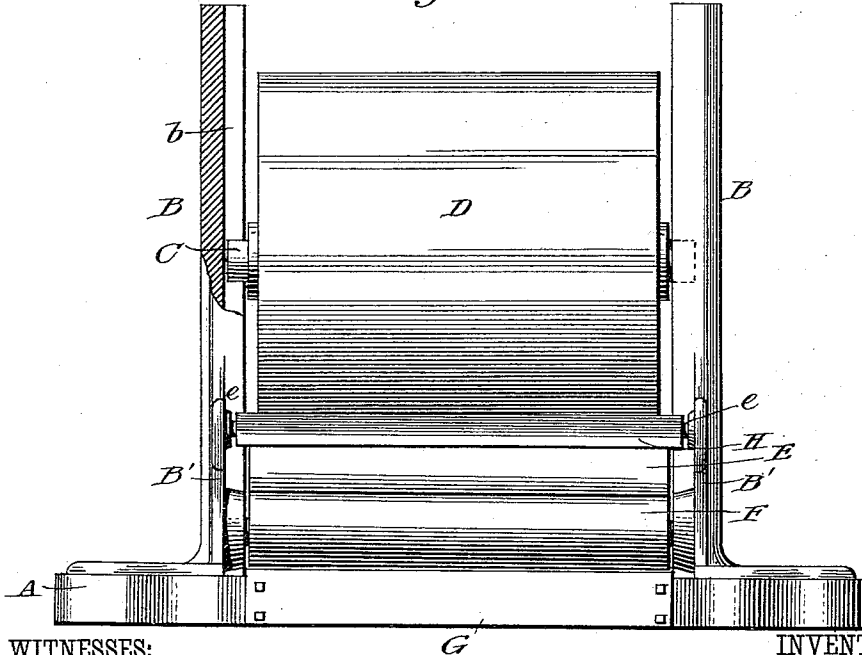

Fig. 2.



WITNESSES:

J. Clark.
C. Sedgwick.

INVENTOR:

BY *J. Zerr.*
Munn & Co.
ATTORNEYS.

UNITED STATES PATENT OFFICE.

JOHN ZERR, OF KEOKUK, IOWA, ASSIGNOR OF ONE-HALF TO EDWARD E. HAWKES, OF SAME PLACE.

ROLL-PAPER HOLDER AND CUTTER.

SPECIFICATION forming part of Letters Patent No. 389,277, dated September 11, 1888.

Application filed December 15, 1887. Serial No. 257,939. (No model.)

To all whom it may concern:

Be it known that I, JOHN ZERR, of Keokuk, in the county of Lee and State of Iowa, have invented a new and useful Improvement in Roll-Paper Holders and Cutters, of which the following is a full, clear, and exact description.

This invention relates to roll-paper holders having attached cutters, which provide for parting the paper by pulling it out sidewise across the cutter as or after a sufficient length of paper has been drawn out from or off the roll for the purpose. In this, as in other roll-paper holders, the roll of paper rests upon a lower roller in the frame of the fixture, but under a different arrangement and in combination with a second lower front roller for certain purposes; and the invention consists in various novel constructions and combinations of parts, including duplicate cutters arranged one above the other, substantially as hereinafter described, and pointed out in the claims.

Reference is to be had to the accompanying drawings, forming a part of this specification, in which similar letters of reference indicate corresponding parts in both the figures.

Figure 1 represents a vertical central section, transversely to the axis of the roll of paper, of a roll-paper holder with attached cutters embodying my invention; and Fig. 2, a front elevation of the same, with one of the standards of the main frame partly broken away.

A is the base of the fixture, on which are mounted two opposite side standards or uprights, B B, that may be of metal, and are provided with front opposite side extensions or arms, B' B'. The standards B B have each a vertical or longitudinal groove, *b*, on their inner face adapted to guide and receive freely within them reduced ends of the pin or roller C, on which the paper D in roll form is wrapped. Said roll of paper and the roll or roller C carrying it are thus free to turn and to fall as the paper by draft on it is used up, and the roll of paper rests below upon a wooden or other roller, E, having its end bearings in the opposite side standards, B B, centrally under the axis of the roll C. Thus the roll of paper is balanced upon the roller E and is

guided vertically downward by the ends of the pin or roll C in the grooves *b* of the standards B B as the paper is reduced by draft on it.

At a short distance in front of the roller E is another wooden or other roller, F, having its end bearings also in the standards or their front extensions, B' B'. The paper D, as it is drawn from the roll, passes under this second roller, F, which serves to give a certain tension or hold on the paper that facilitates its cut while being parted, and that also has the effect of preventing increase of slack in the paper on its roll as the paper is reduced by repeated drafts on the roll, the roller E operating in conjunction with the roller F to secure a delivery of the paper at all times free from objectionable slack and with the proper amount of friction to secure an easy draft regardless of the weight of the roll of paper or without adding specially to its weight.

The paper D as it is drawn out in front of the fixture to be parted in any desired lengths from time to time, as required, is so separated by giving it a slight pull sidewise over a suitable cutter. The cut is made in front of the fixture, and the free-end portion of the roll of paper is thrown up ready for the fingers to take hold of it again by a rise or projection, *d*, on the base A of the fixture.

To adapt the fixture to use at different elevations, I provide it with two independent cutters, arranged the one above the other at a suitable distance apart. Thus G indicates a lower front cutter or cutting-blade secured to the front end of the base A. This cutter will be used when the fixture is placed at a suitable elevation to provide for pulling down on the free end of the paper when tearing it apart by a side pull of it over the cutter. In some cases, however, it is not practicable or convenient to thus arrange the fixture, but necessary to place it at a lower elevation, and so that in order to part the paper it will be requisite to pull upward on the free end of it, as shown by dotted line in Fig. 1, and to pull it sidewise over the cutter. To this end I arrange an additional upper front cutter, H, with a suitable intervening space between it and the lower cutter. This upper cutter I prefer to construct, as shown, of a three or other many sided bar hav-

ing its sides concave and forming cutting or tearing edges at its meeting angles throughout its length, thereby providing for a series of changeable cutting-edges. This bar or cutter is free to turn by trunnions at its ends in bearings *e e* on the extensions or front arms, B' B', of the standards, whereby it is made to adjust itself to any angle at which the paper is drawn from the holder.

10 Having thus described my invention, what I claim as new, and desire to secure by Letters Patent, is—

1. In a roll-paper holder, the combination of the vertically-grooved standards, the paper-carrying roll or pin adapted to turn at its ends within the grooves of the standards and to move freely down therein, a bearing-roller for the roll of paper arranged centrally beneath the roll, and a front lower roller in advance of the bearing-roller, adapted to receive the free end of the paper beneath it from the roll, substantially as and for the purposes specified.

2. In a roll-paper holder provided with a cutter, the combination, with the roller F, under which the paper is passed from the roll, of the base A, provided with a projection, *d*, arranged

in rear of the cutter, essentially as and for the purposes described.

3. In a roll-paper holder, the combination, with the roll which carries the paper and a guide or roller under which the paper is passed as it is drawn from the roll, of two front cutters arranged one above the other, substantially as and for the purposes specified.

4. In a roll-paper holder provided with a cutter, the many and concave sided cutter or bar H, fitted to rotate and adjust itself within the holder to different angles of draft from the roll, essentially as specified.

5. In a roll-paper holder and cutter, the combination of the grooved standards B B, the roll or pin C, on which the paper is reeled, adapted to fit said standards, as described, the roll of paper bearing roll E, arranged parallel with and centrally beneath the roll C, the front lower roller, F, and the lower and upper cutters, G H, substantially as specified.

JOHN ZERR.

Witnesses:

WILLIAM J. SCHLOTTER,
JOHN NORTH.