

No. 629,322.

Patented July 18, 1899.

F. CANFIELD.
WIRE FENCE.

(Application filed Nov. 18, 1898.)

(No Model.)

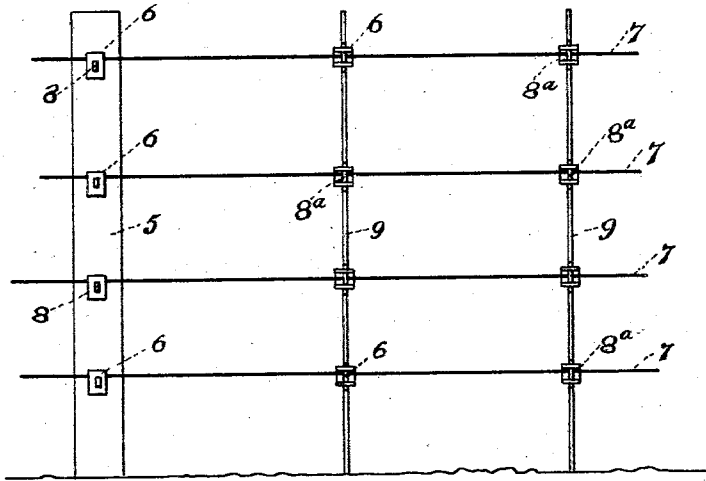

FIG 1

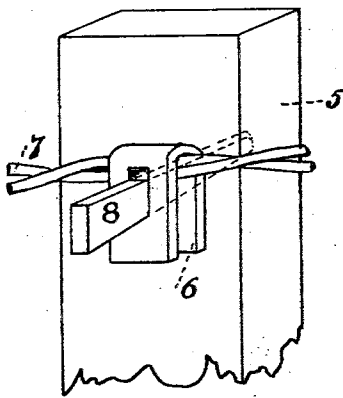

FIG 2

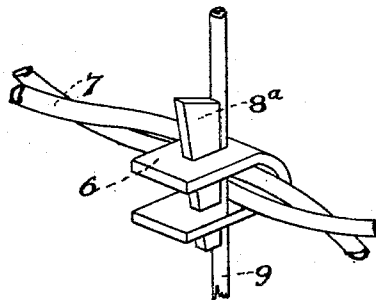

FIG 3

Witnesses
John J. Huddart.
Chas. E. Dawson

FRANK CANFIELD
Inventor

By *his* Attorney *[Signature]*

UNITED STATES PATENT OFFICE.

FRANK CANFIELD, OF BOULDER, COLORADO, ASSIGNOR OF ONE-HALF TO
THOMAS V. WILSON AND T. J. THOMPSON, OF SAME PLACE.

WIRE FENCE.

SPECIFICATION forming part of Letters Patent No. 629,322, dated July 18, 1899.

Application filed November 18, 1898. Serial No. 696,777. (No model.)

To all whom it may concern:

Be it known that I, FRANK CANFIELD, a citizen of the United States of America, residing at Boulder, in the county of Boulder and State of Colorado, have invented certain new and useful Improvements in Wire Fences; and I do declare the following to be a full, clear, and exact description of the invention, such as will enable others skilled in the art to which it appertains to make and use the same, reference being had to the accompanying drawings, and to the figures of reference marked thereon, which form a part of this specification.

My invention relates to improvements in wire fences, my object being to provide a fence of this class which shall be simple in construction, economical in cost, reliable, durable, and efficient in use; and to these ends the invention consists of the features, arrangements, and combinations hereinafter described and claimed, all of which will be fully understood by reference to the accompanying drawings, in which is illustrated an embodiment thereof.

In the drawings, Figure 1 is a side elevation of my improved fence. Fig. 2 is a perspective view showing one of the wood posts and illustrating the devices for fastening the wire thereto, the parts being shown on a larger scale. Fig. 3 is a similar view illustrating one of the vertical metal rods and the manner of fastening the wire thereto, the parts also being shown on a larger scale than in Fig. 1.

Similar reference characters indicating corresponding parts in these views, let the numeral 5 designate the wood posts, which are set into the ground and located at suitable intervals. The wires are fastened to these posts by means of U-shaped clips or keepers 6. This keeper is formed from a flat piece of metal bent into a U-shaped clip having parallel arms. The bend of the keeper opposite the opening between its arm extremities is closed. Within each keeper and engaging the closed end thereof is placed the wire 7, which may be composed of a single strand or of a plurality of strands twisted together, as shown in the drawings, or otherwise connected in suitable proximity to each other. The arms of the keeper 6 are apertured to receive a

wedge-shaped key 8, which is driven through the said arm-openings into the posts, thereby securely fastening the wire to the clip and the latter to the post.

Intermediate the wood posts 5 are placed the auxiliary metal rods 9. In this case the keeper 6 is slipped over the wire 7, the latter engaging the closed end of the same. The vertical rod is then passed through the opening in the keeper-arms in front of the wire, after which the wedge-shaped key 8^a is inserted in the arm-openings in front of and engaging the rod. In this case it will be observed that the keeper occupies a horizontal position and the key a vertical position, while when used in connection with the posts 5 the keeper occupies a vertical position and the key a horizontal position. In both cases, however, the wire 7 is passed through the U-shaped opening between the arms of the keeper, while the key is passed through registering openings formed in the keeper-arms and occupies a position at right angles to the wire and transverse to the arms of the keeper. The opening in the upper arm of the U-shaped keeper or the arm through which the wedge-shaped key is first passed is larger than the opening in the lower arm to make the wedge-shaped key fit tightly in both openings or in both arms. It will also be observed that the bend of the keeper directly opposite the wedge is closed, thus forming an integral or closed bearing for the wire directly opposite the point where the wedging force is applied.

In Fig. 1 of the drawings the fence is shown constructed of four wires. Each of these wires is fastened to each post 5 by means of a vertical keeper 6 and a wedge-shaped key-spike 8 passed through the opening in the keeper-arms and driven into the post. Each of these wires is also fastened to each vertical rod or auxiliary bar 9 by means of a horizontal keeper 6 and a wedge-shaped key 8^a, the latter being passed through the openings in the keeper-arms and occupying a position parallel with the rod or bar.

It must be understood that my improved fastening means may be employed in connection with telegraph, telephone, or any other wires, as well as fence-wires.

Having thus described my invention, what I claim is—

1. Means for fastening wires to posts, rods or bars, comprising a U-shaped keeper-plate having apertured arms, and a wedge-shaped key adapted to pass through the openings in the keeper-arms, the opening in the upper arm, or that through which the keeper is first passed, being larger than the opening in the opposite arm, the arrangement being such that the wedge-shaped key just fills the opening in each arm, the wire occupying a position between the bent end of the keeper and the key, the bent end of the keeper forming a bearing for the wire, said bearing being closed directly opposite the key, whereby the wire cannot yield or bend in response to the force of the key.

2. In a wire fence, the combination with the wires, suitable posts and auxiliary vertical rods or bars, located between the posts, of means for fastening the wires to the rods,

comprising a U-shaped keeper having openings in its arms and a wedge-shaped key passed through said openings, the opening in the upper arm, or that through which the keeper is first passed, being larger than the opening in the opposite arm to make the wedge-shaped key exactly fit in the space left for it in both arms, the wire being embraced by the keeper-arms and located at its bent end, the rod being passed through the openings in the keeper-arms between the key and the wire and occupying a position parallel with the key, and at right angles to the wire. In testimony whereof I affix my signature in presence of two witnesses.

FRANK CANFIELD.

Witnesses:

H. P. WALKER,

B. F. PINE.