

(19)



(11)

EP 4 086 529 A1

(12)

EUROPEAN PATENT APPLICATION

(43) Date of publication:
09.11.2022 Bulletin 2022/45

(51) International Patent Classification (IPC):
F24F 9/00 (2006.01)

(21) Application number: **22171691.3**

(52) Cooperative Patent Classification (CPC):
F24F 9/00

(22) Date of filing: **04.05.2022**

(84) Designated Contracting States:
AL AT BE BG CH CY CZ DE DK EE ES FI FR GB GR HR HU IE IS IT LI LT LU LV MC MK MT NL NO PL PT RO RS SE SI SK SM TR
 Designated Extension States:
BA ME
 Designated Validation States:
KH MA MD TN

(71) Applicant: **Zambolin, Marco**
28013 Gattico-Veruno (NO) (IT)

(72) Inventor: **Zambolin, Marco**
28013 Gattico-Veruno (NO) (IT)

(74) Representative: **PGA S.p.A.**
Via Mascheroni, 31
20145 Milano (IT)

(30) Priority: **05.05.2021 IT 202100011510**

(54) **MODULAR ELEMENT FOR AIR CURTAIN BARRIERS, DYNAMIC AIR CURTAIN BARRIER AND PROCESS FOR THE PRODUCTION THEREOF**

(57) A modular element for dynamic air curtain barriers comprising a supporting frame extending along a prevalent direction D and having a lateral wall internally defining a housing compartment defining longitudinal openings. The supporting frame is associable with a ventilating device generating an air flow directed to the housing compartment and exiting the supporting frame by a lateral through opening. The modular element comprises a manifold arranged within the housing compartment and having axial openings to receive the air flow from the

ventilating device. An internal passage volume is delimited by a manifold lateral wall and by the axial openings, wherein the air flow enters the internal passage volume through the axial openings, and exit from the housing compartment through a lateral through opening of the manifold lateral wall along a direction S of ejection. The modular element comprises a soundproofing element arranged in a soundproof volume within the housing compartment.

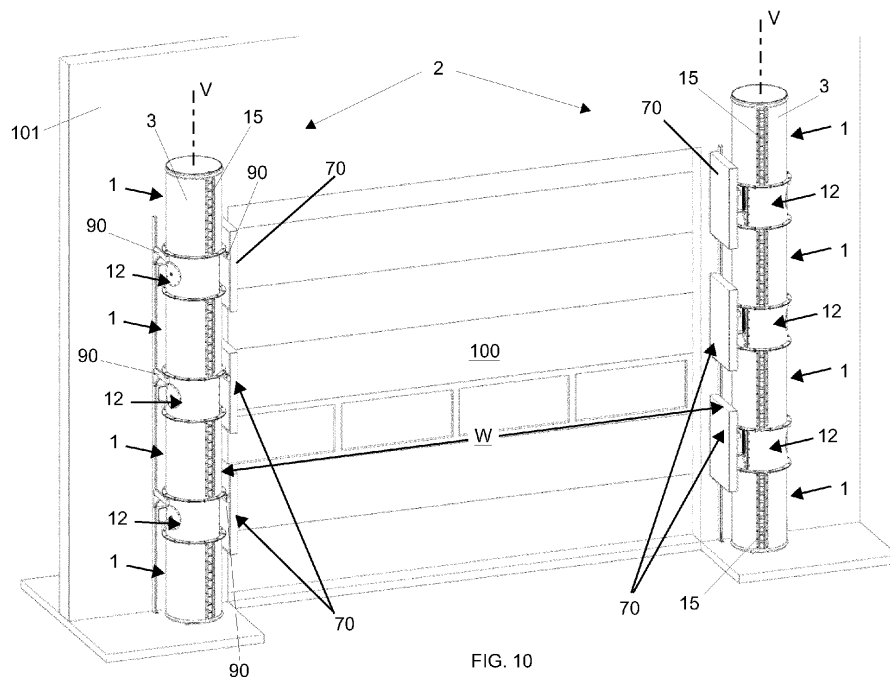

FIG. 10

EP 4 086 529 A1

Description**FIELD OF THE INVENTION**

[0001] The present invention relates to a modular element for dynamic air curtain barriers and a dynamic air curtain barrier. Air curtain barriers are in general systems that produce one or more air jets, hot or cold or at room/ambient temperature, along industrial doors in factories, warehouses, hangars or garages, or at the entrance of commercial buildings such as supermarkets, shops, bars, hotels or in general establishments. Air curtain barriers may be used as dynamic thermal insulator in order to shield an indoor room from the outer environment. In more detail, the present dynamic air curtain uses cold air (the device sucks air at ambient temperature and is configured to work outside the environment to be thermally insulated, e.g., outside the building access) to generate the air curtain.

BACKGROUND ART

[0002] These barriers create an effective "air barrier" which limits heat exchanges in order to protect indoor thermal conditions in a building, i.e. to maintain the desired temperature and avoid thermal losses. Air curtain barriers do not treat the air but are an aid to the air conditioning system: they thermally insulate one environment from another, without necessarily having to close the doors, by creating a dynamic air barrier. They produce a continuous jet of air (at least under conditions where the door is open) which is often intense in proximity to the entrance of the interior to be thermally insulated; the barrier produced does not permit the treated air to mix rapidly with that of another environment, e.g. with outdoor air.

[0003] The currently available systems are generally installed above the entrance, with the air jet directed downwards. Alternative solutions, though less widespread, provide for the system to be installed at the sides of entrance doorways or even embedded in the floor. These systems draw air, for example, from inside the air-conditioned interior and direct it along a vertical plane, in such a way as to create a sort of air "barrier" at the entrance. When the entrance to the air-conditioned interior is opened, the pressure equilibrium profile changes and currents of air are generated in proximity to the entrance; obviously, the flows will be such as to tend toward equalizing the temperature of the two communicating environments and therefore in some areas of the entrance currents of air toward the outside environment will be created, whereas in others there will be currents in the opposite direction. Complex patterns of currents will thus be originated and they can also have a non-uniform distribution in terms of speed. Therefore, it is desirable to create an air curtain barrier capable of suitably opposing the currents that are created after the entrance is opened.

[0004] Document EP2995876 further discloses air cur-

tain barriers having a modular element comprising a supporting tubular frame having a lateral wall. The lateral wall internally defines a housing compartment extending along a prevalent direction D and comprises first and a second longitudinal openings configured to receive an air flow from a ventilating device. The supporting frame further comprises a lateral through opening substantially extending along the prevalent direction D and configured to exit the air flow coming from the ventilating device. A channel is engaged with the supporting frame and configured to receive the air flow from the ventilating device and to channel it along a direction S of ejection out through the lateral opening. The channel is defined by a first and a second longitudinal channelling wall inside the housing compartment, wherein each channelling wall has an inlet portion and an outlet portion: the respective inlet portions define a lateral inlet opening, while the respective outlet portions of the channelling walls define an outlet opening configured to direct the air flow along the ejection direction S. However, the air barriers of the prior art are affected by noise pollution due to the air flowing within the inner channels and due to the motor fan.

[0005] EP155924 discloses an air stream-generating curtaining unit to be included as one of several curtaining units situated in a row in an air curtaining installation. The unit comprises a fan unit arranged in a casing with inlets and outlets for a partial curtain forming air stream driven by the fan unit for the air curtain. The outlet of the curtaining unit is provided with a combined silencing and air distribution means having an air supply nozzle which has a rectangular through-flow cross section with long sides extending along the entire curtaining length of the unit, and with short sides of decreasing length along the flow path of the partial air stream. The defining walls of the supply air nozzle forming the long sides have their profile convex shaped in the flow direction. Both defining walls (each define one side of a box) are filled with porous material exterior to and facing towards the nozzle; the box serving as a resistive and reactive silencer, the only open communication of the box with the supply air nozzle being a pierced portion of the defining wall.

OBJECT OF THE INVENTION

[0006] The object of the present invention is to substantially overcome at least one of the drawbacks and/or limitations of the prior solutions. In particular an object of the present invention is to provide a modular element for air barriers having noise reduction properties. Another object of the present invention is to provide an air barrier curtains able to reduce the noise generated by the ventilating device. It is an object of the present invention to provide a modular structure for air curtain barriers to ease installation and removal procedures and to allow improved customization to adapt to different contexts. In addition, it is an object of the present invention to provide a structure for air curtain barriers with improved thermal

insulation properties.

[0007] One or more of the above-described objects, which will become more apparent in the course of the description that follows, are substantially achieved by a modular structure and an air curtain barrier in accordance with one or more of the accompanying claims and/or aspects.

SUMMARY

[0008] Aspects of the invention are described here below.

[0009] A 1st aspect is directed to a modular element (1) for dynamic air curtain barriers (2), said modular element (1) comprising:

- at least one supporting frame (3) extending along a prevalent direction (D) of extension between a first and a second longitudinal ends (3a, 3b), said supporting frame (3) having a lateral wall (4) internally defining a housing compartment (5) and which defines, at the first and second ends (3a, 3b) of the supporting frame (3), a respective first and second longitudinal openings (6, 7), the supporting frame (3) further comprising at least one lateral through opening (8) substantially extending along the prevalent direction (D) of extension of the supporting frame, the supporting frame (3) being associable with at least one ventilating device (12) configured to generate an air flow destined for the housing compartment (5) of the supporting frame (3) and passing through at least one of said first and second longitudinal openings (6, 7) and exiting the supporting frame (3) through the lateral through opening (8).

[0010] In a 2nd aspect according to the preceding aspect, the modular element further comprises at least one manifold (9) arranged within the housing compartment (5) of the supporting frame (3), said manifold comprising a manifold lateral wall (10) engaged with said supporting frame (3) and extending substantially along the prevalent direction (D) of the supporting frame (3) between a first and a second end edges (11a, 12a), the first and the second end edges (11a, 12a) defining, at least partially, respective first and second axial openings (17, 18) configured to receive the air flow from the ventilating device (12) along a direction substantially parallel to the prevalent direction (D) of extension of the supporting frame (3), an internal passage volume (22) being at least partially laterally delimited by the manifold lateral wall (10) and by the first and second axial openings (13, 14) In a 3rd aspect according to the preceding aspect, the manifold lateral wall (10) further comprises a lateral through opening (15) fluidly connecting said internal passage volume (22) of the manifold (9) with the lateral through opening (8) of the supporting frame (3), wherein the air flow is configured to pass through at least one of said first and

second longitudinal openings (6, 7), enter into the internal passage volume (22) through at least one of the first and the second axial openings (17, 18) of the manifold lateral wall (10), and exit from the housing compartment (5) through the lateral through opening (15) of the manifold lateral wall (10) and the lateral through opening (8) of the supporting frame (3) along a direction (S) of ejection.

[0011] In a 4th aspect according to any one of the preceding aspects, the modular element further comprises a soundproofing element (40) arranged in at least one soundproof volume (41) within the housing compartment (5), the soundproof volume (41) being interposed between the manifold lateral wall (10) of the manifold (9) and the lateral wall (4) of the supporting frame (3).

[0012] In a 5th aspect according to any one of the preceding aspects, the manifold lateral wall (10) comprises a first and a second manifold lateral walls (10a, 10b) having at least a portion converging each other between a first section of minimum distance (Dmin) and a second section of maximum distance (Dmax), optionally the first and the second manifold lateral walls (10a, 10b) being convergent each other along the entire extension.

[0013] In a 6th aspect according to the preceding aspect, the second section of the manifold lateral wall (10) is opposite to the lateral through opening (8) of the supporting frame (3) with respect to the prevalent direction (D) of the supporting frame (3).

[0014] In a 7th aspect according to any one of the preceding two aspects, the lateral through opening (15) of the manifold wall (10) coincides with the first section of minimum distance (Dmin).

[0015] In a 8th aspect according to any one of the preceding aspects, the first manifold lateral wall (10a) extends along the prevalent direction (D) of the supporting frame (3) between a respective first end edge (11a) and a respective second end edge (12a); and the second manifold lateral wall (10b) extends along the prevalent direction (D) of the supporting frame (3) between a respective first end edge (11b) and a respective second end edge (12b).

[0016] In a 9th aspect according to the preceding aspect, at least a portion of the first end edge (11a) of the first manifold lateral wall (10a) is convergent, in particular transversal, to a respective portion of the first end edge (11b) of the second manifold lateral wall (10b), optionally the first end edge (11a) of the first manifold lateral wall (10a) being entirely convergent, in particular transversal, to the first end edge (11b) of the second manifold lateral wall (10b).

[0017] In a 10th aspect according to the two preceding aspects, at least a portion of the second end edge (12a) of the first manifold lateral wall (10a) is convergent, in particular transversal, to a respective portion of the second end edge (12b) of the second manifold lateral wall (10b), optionally the second end edge (12a) of the first manifold lateral wall (10a) being entirely convergent, in particular transversal, to the second end edge (12b) of the second manifold lateral wall (10b).

[0018] In a 11th aspect according to any one of the preceding aspects, the first and the second manifold lateral walls (10a) define respective plane walls converging each other between the first section of minimum distance (Dmin) and the second section of maximum distance (Dmax).

[0019] In a 12th aspect according to any one of the preceding aspects, the first manifold lateral wall (10a) extends transversal, in particular orthogonal, to the prevalent direction (D) of the supporting frame (3) between a first outlet edge (13a) and a first inner edge (14a); and the second manifold lateral wall (10b) extends transversal, in particular orthogonal, to the prevalent direction (D) of the supporting frame (3) between a second outlet edge (13b) and a second inner edge (14b).

[0020] In a 13th aspect according to the preceding aspect, the first outlet edge (13a) and the second outlet edge (13b) are substantially parallel each other and distanced by said minimum distance (Dmin).

[0021] In a 14th aspect according to the preceding two aspects, the first inner edge (14a) and the second inner edge (14b) are substantially parallel each other and distanced by said maximum distance (Dmax).

[0022] In a 15th aspect according to any one of the preceding aspects, the first outlet edge (13a), the first inner edge (14a), the second outlet edge (13b) and the second inner edge (14b) are substantially parallel each other.

[0023] In a 16th aspect according to any one of the preceding aspects, the first and the second outlet edges (13a, 13b) are opposite to the first and the second inner edges (14a, 14b) with respect to the prevalent direction (D) of the supporting frame (3).

[0024] In a 17th aspect according to any one of the preceding aspects, the first and the second outlet edges (13a, 13b) respectively of the first and second manifold walls (10a, 10b) define at least partially the through opening (15) of the manifold wall (10) of the manifold (9).

[0025] In a 18th aspect according to any one of the preceding aspects, the first and the second outlet edges (13a, 13b) are engaged to the lateral wall (4) of the supporting frame (3).

[0026] In a 19th aspect according to any one of the preceding aspects, the first and second inner edges (14a, 14b) respectively of the first and second manifold walls (10a, 10b) are engaged to the lateral wall (4) of the supporting frame (3), in particular to an inner surface of the lateral wall (4) of the supporting frame (3).

[0027] In a 20th aspect according to any one of the preceding aspects, the manifold lateral wall (10) defines, entirely by itself or in combination with a portion of the lateral wall (4) of the supporting frame (3), a closed-loop lateral surface entirely delimiting laterally the internal passage volume (22), in particular except for the through opening (15).

[0028] In a 21st aspect according to the preceding aspect, the closed-loop lateral surface is either air-tight, wherein gas passage through the manifold lateral wall

(10) between the internal passage volume (22) and the soundproof volume (41) is prevented; or the manifold lateral wall (10) comprises through holes (20) which allows the internal passage volume (22) to be in fluid communication with the soundproof volume (41), in particular wherein a maximum size of said through holes (20) is "n"-times lower than a respective size of the first and/or the second axial openings (17, 18), wherein the "n" term is comprised between 3 and 1000, more in particular between 10 and 500.

[0029] In a 21st bis aspect according to the preceding aspect, the through holes (20) of the manifold lateral wall (10), in particular of the first and second manifold lateral walls (10a, 10b), are manufactured by an expanded metal process.

[0030] In a 21st bis aspect according to the preceding aspect, the expanded metal process comprises the steps of performing a plurality of through cuts in the manifold lateral wall (10) wherein the through cuts extend substantially along a first direction, and subsequently stretching the manifold lateral wall (10) along a second direction substantially orthogonal to said first direction.

[0031] In a 21st ter aspect according to the preceding aspect, the through holes (20) made by expanded metal process have a substantially rhomboidal shape.

[0032] In a 22nd aspect according to any one of the preceding aspects, the soundproofing element (40) comprises at least one between rock wool, cork, wood fiber, hemp, jute, rubber, foam in particular polyurethane or polyethylene foam, cotton or cotton fibres.

[0033] In a 23rd aspect according to any one of the preceding aspects, the soundproofing element (40) is made by a fibrous or a foam based material.

[0034] In a 24th aspect according to any one of the preceding aspects, the soundproofing element (40) has a density comprised between 30 and 150kg/m³.

[0035] In a 25th aspect according to any one of the preceding aspects, the soundproof volume (41) is entirely filled by the soundproofing element (40), the soundproofing element (40) extending entirely from the first end edge (11a) to the second end edge (12a) of the manifold lateral wall (10).

[0036] In a 26th aspect according to any one of the preceding aspects, the soundproofing element (40) contacts an inner surface of the lateral wall (4) of the supporting frame (3) and an outer surface of the manifold wall (10).

[0037] In a 27th aspect according to any one of the preceding aspects, the housing compartment (5) comprises at least a first and a second soundproof volumes (41a, 41b) housed within the housing compartment (5) of the supporting frame (3).

[0038] In a 28th aspect according to the preceding aspect, the internal passage volume (22) is interposed between the first and the second soundproof volumes (41a, 41b) with respect a direction orthogonal to the prevalent direction (D) of the supporting frame (3).

[0039] In a 29th aspect according to the two preceding

aspects, the first and the second soundproof volumes (41a, 41b) are substantially equal in volume and shape each other.

[0040] In a 30th aspect according to any one of the preceding aspects, the internal passage volume (22) of the manifold (9) is interposed between the first and the second soundproof volumes (41a, 41b) with respect to a direction orthogonal to the prevalent direction (D) of the supporting frame (3).

[0041] In a 31st aspect according to any one of the preceding aspects, the soundproofing element (40) entirely laterally surrounds the manifold (9), in particular the internal passage volume (22) of the manifold (9), except for the through opening (15) of the manifold (9).

[0042] In a 32nd aspect according to any one of the preceding aspects, the soundproofing element (40) entirely laterally surrounds the manifold (9) along a direction orthogonal to the prevalent direction (D) of the supporting frame (3), so that the soundproofing element (40) is entirely interposed between the manifold (9) and the lateral wall (4) of the supporting frame (3), in particular the soundproofing element (40) being entirely interposed between the internal passage volume (22) of the manifold (9) and the lateral wall (4) of the supporting frame (3).

[0043] In a 33rd aspect according to any one of the preceding aspects, the first and the second longitudinal openings (6, 7) fluidly communicates with both the internal passage volume (22) and the at least one soundproof volume (41), in particular with the internal passage volume (22) and the first and second soundproof volumes (41a, 41b).

[0044] In a 34th aspect according to any one of the preceding aspects, the manifold lateral wall (10) comprises a third manifold lateral wall (10c) arranged within the housing compartment (5) and extending along the prevalent direction (D).

[0045] In a 35th aspect according to the preceding aspect, the third manifold lateral wall (10c) is interposed between, and connecting, the first manifold lateral wall (10a) and the second manifold lateral wall (10b), the internal passage volume (22) being laterally delimited by the first, the second and the third lateral walls (10a, 10b, 10c).

[0046] In a 36th aspect according to the two preceding aspects, the third manifold lateral wall (10c) is arranged opposite to the through opening (15) of the manifold (9) with respect to the prevalent direction (D).

[0047] In a 37th aspect according to the three preceding aspects, the third manifold lateral wall (10c) is arranged closer to an inner surface of the lateral wall (4) of the supporting frame (3) than to the through opening (15).

[0048] In a 38th aspect according to any one of the preceding aspects, the internal passage volume (22) is entirely laterally surrounded by the soundproof volume (40), in particular except for the lateral through opening (15).

[0049] In a 39th aspect according to any one of the preceding aspects, the housing compartment (5) com-

prises a third soundproof volume (41c) containing the soundproofing element (40), the third soundproof volume (41c) being delimited by the third manifold lateral wall (10c) and by a portion of the lateral wall (4) of the supporting frame (3), in particular the third soundproof volume (41) being further delimited by a portion of the first and the second manifold lateral walls (10a, 10b).

[0050] In a 40th aspect according to the preceding aspect, the internal passage volume (22) is divided from the third soundproof volume (41c) by said third manifold lateral wall (10c).

[0051] In a 41st aspect according to any one of the preceding aspects, the first soundproof volume (41a) is separated from the third soundproof volume (41c) by a portion of the first manifold lateral wall (10a); and the second soundproof volume (41b) is separated from the third soundproof volume (41c) by a portion of the second manifold lateral wall (10b).

[0052] In a 42nd aspect according to any one of the preceding aspects, the third soundproof volume (41c) is directly interposed between the first and the second soundproof volumes (41a, 41b).

[0053] In a 43rd aspect according to any one of the preceding aspects, the modular element (1) further comprises at least one cover cap (50) arranged within, in particular entirely within, the housing compartment (5), said cover cap (50) extending transversal, optionally orthogonal, to the prevalent direction (D) of the supporting frame (3) between the first and/or the second end edges (11a, 12a) of the manifold (9) and a portion of the lateral wall (4) of the supporting frame (3), said cover cap (50) covering the soundproof volume (41) and the soundproofing element (40).

[0054] In a 44th aspect according to the preceding aspect, said cover cap (50) is configured to prevent, or limit an amount of, the air flow coming from the ventilating device (12) to enter the soundproof volume (41).

[0055] In a 45th aspect according to any one of the preceding aspects, the modular element (1) comprises a first and a second cover cap (50a, 50b) of said at least one cover cap (50), wherein the first cover cap (50a) is arranged as a cover of the first soundproof volume (41a) and the second cover cap (50b) is arranged as a cover of the second soundproof volume (41b), optionally the modular element (1) comprising a third cover cap (50c) of said at least one cover cap (50) arranged as a cover of the third soundproof volume (41c).

[0056] In a 46th aspect according to any one of the preceding aspects, the first cover cap (50a) comprises a first upper cover cap (50a') arranged at the first end edge (11a) of the manifold wall (10), and a first lower cover cap (50a'') arranged at the second end edge (12a) of the manifold wall (10).

[0057] In a 47th aspect according to any one of the preceding aspects, the second cover cap (50b) comprises a second upper cover cap (50b') arranged at the first end edge (11a) of the manifold wall (10), and a second lower cover cap (50b'') arranged at the second end edge

(12a) of the manifold wall (10).

[0058] In a 48th aspect according to any one of the preceding aspects, the third cover cap (50c) comprises a third upper cover cap (50c') arranged at the first end edge (11a) of the manifold wall (10), and a third lower cover cap (50c'') arranged at the second end edge (12a) of the manifold wall (10).

[0059] In a 49th aspect according to any one of the preceding aspects, the at least one cover cap (50), in particular the first and the second cover caps (50a, 50b) and optionally the third cover cap (50c), defines a closed surface (51) configured to prevent, in particular to prevent completely, the air flow from the ventilating device (12) to cross the cover cap (50) and enter the soundproof volume (41).

[0060] In a 49th bis aspect according to any one of the preceding aspects, the at least one cover cap (50), in particular the first and the second cover caps (50a, 50b) and optionally the third cover cap (50c), defines a surface having through holes (51) configured to allow at least partially the air flow from the ventilating device (12) to cross the cover cap (50) and enter the soundproof volume (41).

[0061] In a 50th aspect according to any one of the preceding aspects, the first and second axial openings (17, 18) of the manifold (9) have an extension size, and the through holes (20) of the at least one cover cap (50) have a respective extension size, a maximum size of the through holes (51) being "n"-times lower than the respective size of the first and/or the second axial openings (17, 18) of the manifold (9), wherein the "n" term is comprised between 3 and 1000, more in particular between 10 and 500.

[0062] In a 51st aspect according to any one of the preceding aspects, the first and/or the second axial openings (17, 18) of the manifold (9) are not covered or obstructed by a cover, so that the air flow coming from the ventilating device (12) is configured to enter the internal passage volume (22) directly, in particular wherein the internal passage volume (22) is in direct fluid communication with the ventilating device (12).

[0063] In a 52nd aspect according to any one of the preceding aspects, the through opening (15) of the manifold wall (10) has a rectangular or trapezoidal or triangular shape, in particular said shape defining the outlet section configured to allow the air flow to exit the housing compartment (5).

[0064] In a 53rd aspect according to any one of the preceding aspects, the through opening (15) of the manifold wall (10) has a rectangular parallelepiped shape having a length directed as the prevalent direction (D) of the supporting frame (3), a width orthogonal to said length and defining, in combination with said length, an outlet section configured to allow the air flow to exit the housing compartment (5), and a depth extending internally to the housing compartment (5) starting from an external surface of the lateral wall (4) of the supporting frame (3), said depth being comprised between 3cm and 15cm

and/or being set as a function of said length and/or of said width, in particular wherein said depth is higher than said width, more in particular wherein said depth is 10% to 300% higher than the width, in particular said depth being 50% to 100% higher than the width of the through opening (15).

[0065] In a 54th aspect according to any one of the preceding aspects, the through opening (15) of the manifold wall (10) has a rectangular shape having a length directed as the prevalent direction (D) of the supporting frame (3) and a width orthogonal to said length, said width being comprised between 3cm and 10cm and/or being set as a function of said length, in particular wherein said width is comprised between 1% and the 20% of the length, more in particular higher than 2%-3% and more in particular between the 3% and the 10%.

[0066] In a 55th aspect according to any one of the preceding aspects, the manifold (9) has an outlet parallel portion defined by substantially parallel lateral walls of the manifold wall (10), in particular by a respective parallel portions of the first and the second manifold walls (10a, 10b), facing each other and extending up to the through opening (15) of the manifold lateral wall (10).

[0067] In a 56th aspect according to the preceding aspect, the outlet portion of the manifold (9) extends along the prevalent direction (D) of the supporting frame (3); and along a direction orthogonal to the prevalent direction (D) between an end edge of the converging portion and an outlet edge of the first and the second manifold lateral walls (10a, 10b), the outlet edge of the first and the second manifold lateral walls (10a, 10b) coinciding with the lateral through opening (15) of the manifold lateral wall (10), and in particular wherein a distance between said parallel lateral walls of the manifold wall (10) defining the first section of minimum distance (D_{min}). In a 57th aspect according to any one of the preceding aspects, the outlet parallel portion of the manifold (9) extends between the outlet edge to the end edge of the converging portion by a length comprised between 3 cm and 20cm.

[0068] In a 58th aspect according to any one of the preceding aspects, the first and second manifold walls (10a, 10b) define, at least at the converging portion, an angle in between comprised between 20° and 120°, in particular between 30° and 90°, more in particular between 40° and 70°.

[0069] In a 59th aspect according to any one of the preceding aspects, both the converging portion and the outlet parallel portion of the manifold (9) are entirely arranged within the housing compartment (5) of the supporting frame (3).

[0070] In a 60th aspect according to any one of the preceding aspects, the lateral wall (4) of the supporting frame (3) has tubular shape extending along a frame axis (FA) coincident with the prevalent direction (D) of the supporting frame (3), the lateral wall (4) having a diameter, in particular an external diameter, comprised between 50cm and 200cm.

[0071] In a 61st aspect according to any one of the

preceding aspects, the outlet parallel portion of the manifold (9) extends between the outlet edge to the end edge of the converging portion by a length comprised 5% and 40% of the diameter of the supporting frame (3), in particular between 10% and 30% of the diameter of the supporting frame (3).

[0072] In a 62nd aspect according to any one of the preceding aspects, the supporting frame (3) extends between the first and the second longitudinal ends (3a, 3b) by a length comprised between 50cm and 300cm, in particular between 75cm and 200cm.

[0073] In a 63rd aspect according to any one of the preceding aspects, the lateral opening (8) of the supporting frame (3) extends over the entire lateral wall (4) of the supporting frame (3) along the prevalent direction (D) of extension, in particular wherein the lateral opening (8) extends from the first longitudinal end (3a) to the second longitudinal end (3b) of the supporting frame (3).

[0074] In a 64th aspect according to any one of the preceding aspects, the manifold wall (10) extends over the entire lateral wall (4) of the supporting frame (3) along the prevalent direction (D) of extension, in particular the manifold wall (10) of the manifold (9) extends over the entire lateral wall (4) along the prevalent direction (D) of extension between the first and the second longitudinal ends (3a, 3b) of the supporting frame (3).

[0075] In a 65th aspect according to any one of the preceding aspects, a ratio between the maximum distance (D_{max}) and the minimum distance (D_{min}) respectively of the second and first section of manifold wall (10) is greater than 2, in particular it is comprised between 3 and 10.

[0076] In a 66th aspect according to any one of the preceding aspects, the supporting frame (3) comprises at least one coupling portion (26) configured to reciprocally engage, directly or indirectly, with a respective coupling portion (26) of a further modular element (1) and to enable the positioning of the latter in a plurality of different operative positions defining different working conditions of the lateral through openings (8) of the supporting frame (3). In a 67th aspect according to the preceding aspect, the coupling portion (26) is further configured to arranged the through opening (8) of at least one modular element (1) in an operative position different from an operative position of a through opening (8) of a further modular element (1).

[0077] In a 68th aspect according to the two preceding aspects, the at least one coupling portion (26) of one modular element (1) comprises a predetermined number of engagement portions configured to cooperate with respective engagement portions of an adjacent modular element (1) so as to define a predetermined number of operative positions distinct and offset from one another, in particular angularly offset from one another.

[0078] In a 69th aspect according to the three preceding aspects, the engagement portions of one coupling portion (26) comprises a predetermined number of elements, optionally protruding axially, configured to coop-

erate with a respective predetermined number of axial recesses of a coupling portion (26) of an adjacent modular element.

[0079] In a 70th aspect according to any one of the preceding aspects, the manifold (9) comprises a plurality of flaps (60) arranged at the through opening (15) and configured to deflect the air flow exiting the modular element (1), the plurality of flaps further reducing an outlet section of the through opening (15) for the air flow in order to increase air speed.

[0080] In a 71st aspect according to any one of the preceding aspects, the plurality of flaps (60) are mountable on and removable from the modular element (1) from the outside the housing compartment (5), the modular element being configured to house a variable number of flaps (60).

[0081] A 72nd aspect is directed to an assembly comprising a modular element (1) according to any one of the preceding aspects, and a plurality of flaps (60) mountable at the through opening (15) of the manifold (9) and configured to deflect the air flow exiting the modular element (1), said mountable flaps being selectable between different thickness values, a variation of the flap thickness affecting an outlet section of the through opening (15).

[0082] A 73rd aspect is directed to an air curtain barrier (2) comprising at least one modular element (1) according to any one of the preceding aspects, optionally wherein the operative position of the through opening (8) of said at least one modular element (1) being angularly adjustable about the development direction (D) of the supporting frame (3), and at least one ventilating device (12) associated, in particular coupled, to said at least one modular element (1) and configured for generating and delivering the air flow to the housing compartment (5) of the supporting frame (3), wherein the at least one modular element (1) is configured for receiving the air flow from the ventilating device (12) and channelling it outside the through opening (8) along the ejection direction (S).

[0083] In a 74th aspect according to any one of the preceding aspects, the at least one modular element (1) comprises at least a series of modular elements (1), the series of modular elements (1) being reciprocally engaged with each other and consecutively located along a prevalent axis of extension (1a) parallel to the prevalent direction (D) of extension of each modular element (1).

[0084] In a 75th aspect according to any one of the preceding aspects, the operative position of a through opening (8) of at least one modular element (1) is angularly adjustable about the development axis (1a) with respect to an operative position of at least one other lateral outlet opening (8) of a different modular element (1), and wherein the at least one ventilating device (12) is configured for generating and delivering the air flow to the housing compartments (5) of said series of modular elements (1).

[0085] In a 76th aspect according to any one of the preceding aspects the at least a series of modular ele-

ments (1) comprises at least one vertical series of modular elements (1) arranged along a substantial vertical direction one over the other and along the prevalent direction (D) of each supporting frame (3), optionally said vertical series of modular elements (1) defining a substantially rectilinear structure along said vertical direction.

[0086] In a 77th aspect according to any one of the preceding aspects, the at least a series of modular elements (1) comprises at least one horizontal series of modular elements (1) arranged along a substantial horizontal direction and along the prevalent direction (D) of each supporting frame (3), optionally said horizontal series of modular elements (1) defining a substantially rectilinear structure along said horizontal direction.

[0087] In a 78th aspect according to any one of the preceding aspects, the at least a series of modular elements (1) comprises both the vertical and the horizontal series of modular elements.

[0088] In a 79th aspect according to any one of the preceding aspects, the vertical and the horizontal series of modular elements are consecutive each other and optionally in fluid communication each other.

[0089] In a 80th aspect according to any one of the preceding aspects, the at least a series of modular elements (1) comprises a first vertical series of modular elements (1) arranged along a substantial vertical direction one over the other and along the prevalent direction (D) of each supporting frame (3) of said first vertical series, optionally said vertical series of modular elements (1) defining a substantially rectilinear structure along said vertical direction; and a second vertical series of modular elements (1) arranged along a substantial vertical direction one over the other and along the prevalent direction (D) of each supporting frame (3) of said second vertical series, optionally said vertical series of modular elements (1) defining a substantially rectilinear structure along said vertical direction, optionally the a first and the second vertical series of modular elements (1) being substantially parallel each other and separated by a distance W comprised between 1m and 8m, in particular between 2m and 4m;

[0090] In a 81st aspect according to the preceding aspect, the at least a series of modular elements (1) further comprises at least one horizontal series of modular elements (1) arranged along a substantial horizontal direction and along the prevalent direction (D) of each supporting frame (3), optionally said horizontal series of modular elements (1) defining a substantially rectilinear structure along said horizontal direction.

[0091] In a 82nd aspect according to any one of the preceding aspects, the first vertical series of modular elements (1), the second vertical series of modular elements (1), lie on a common reference plane (RP), said reference plane (RP) simultaneously crossing the vertical directions of the first and second vertical series.

[0092] In a 83rd aspect according to any one of the preceding aspects, the first vertical series of modular el-

ements (1), the second vertical series of modular elements (1), and the horizontal series of modular elements (1) lie on a common reference plane (RP), said reference plane (RP) simultaneously crossing the vertical directions of the first and second vertical series and the horizontal direction of the horizontal series of modular elements (1).

[0093] In a 84th aspect according to any one of the preceding aspects, the horizontal series of modular elements (1) is orthogonal to the vertical series of modular elements, in particular orthogonal to both the first and the second vertical series of modular elements.

[0094] In a 85th aspect according to any one of the preceding aspects, the at least one ventilating device (12) comprises a first ventilating device (12a) associated to the vertical series of modular elements (1) and configured to deliver the air flow to the modular elements (1) of said vertical series of modular elements; and a second ventilating device (12b) associated to the horizontal series of modular elements (1) and configured to deliver the air flow to the modular elements (1) of said horizontal series of modular elements; or alternatively the at least one ventilating device (12) comprises a common ventilating device (12) associated to both the vertical and horizontal series of modular elements (1) and configured to deliver the air flow to the modular elements (1) of said vertical and horizontal series of modular elements (1).

[0095] In a 86th aspect according to any one of the preceding aspects, the air curtain barrier comprises the vertical series of modular elements (1) and the horizontal series of modular elements (1), the vertical series of modular elements (1) and the horizontal series of modular elements (1) defining a reference plane (RP) crossing both the vertical and the horizontal directions;

or the air curtain barrier comprises the first and the second vertical series of modular elements (1), the first and the second vertical series of modular elements (1) defining a reference plane (RP) crossing both the vertical directions of the first and second vertical series;

or the air curtain barrier comprises the first vertical series of modular elements (1), the second vertical series of modular elements (1) and the horizontal series of modular elements (1), a reference plane (RP) simultaneously crossing the vertical direction of the first and second vertical series and the horizontal direction of the horizontal series of modular elements (1).

[0096] In a 87th aspect according to any one of the preceding aspects, the ejection direction (S) of each modular element (1) is positioned at a predefined angular orientation with respect to said reference plane (RP), said angular orientation defining an angle included between the reference plane (RP) and the ejection direction (S) comprised between 40° and 85°, in particular between 60° and 80°, more in particular between 65° and 75°. In

a 88th aspect according to any one of the preceding aspects, the ejection directions (S) of each modular elements (1) of the vertical series varies with a distance of the modular element from the ground, in particular the angular orientation of the ejection direction (S) increasing with the distance of the modular element with respect to the ground.

[0097] In a 89th aspect according to any one of the preceding aspects, the ejection directions (S) of each modular elements (1) of the vertical series is constant, in particular not varying with the distance of the modular element with respect to the ground.

[0098] In a 90th aspect according to any one of the preceding aspects, the ventilating device (12) comprises a motor frame (80) defining an internal volume (81), a motor (82), in particular an electric motor, arranged within the internal volume (81) of said motor frame (80), and at least one fan (83), in particular a centrifugal, radial or axial fan, coupled to said motor (82), said motor (82) being configured to rotate the fan (83) to generate the air flow towards said modular element(s).

[0099] In a 91st aspect according to any one of the preceding aspects, the fan is configured to rotate about a rotation axis (RA), optionally coincident with a rotation axis of the motor, transversal, optionally orthogonal, to the prevalent direction (D) of the modular elements (1).

[0100] In a 92nd aspect according to any one of the preceding aspects, the motor frame (80) comprises a lateral wall (84) extending longitudinally between a first and a second edges (85, 86), the first and the second edges (85, 86) defining respectively first and second through openings (85a, 85b) configured to allow the air flow to pass through, and wherein at least one between the first and the second edges (85, 86) of the motor frame (80) is/are engaged to the modular element(s) (1), at least one between the first and the second through openings (85a, 86a) of the motor frame (80) being faced and coincident with one of the first or second longitudinal openings (6, 7) of the supporting frame (3) of the modular element.

[0101] In a 93rd aspect according to any one of the preceding aspects the motor frame (80) has tubular shape defining an axis substantially aligned with the prevalent direction (D) of the at least one modular elements (1).

[0102] In a 94th aspect according to any one of the preceding aspects, the rotation axis of the ventilating device (12) is orthogonal to the ejection direction (S) of the modular element (1).

[0103] In a 95th aspect according to any one of the preceding aspects, the rotation axis of the ventilating device (12) is orthogonal to the prevalent direction (D) of the supporting frame and/or to the frame axis (FA) of the tubular supporting frame (3).

[0104] In a 96th aspect according to any one of the preceding aspects, the ventilating device (12) comprises an intake aperture (87) configured to allow air to be sucked by the fan (83).

[0105] In a 97th aspect according to any one of the preceding aspects, the air curtain barrier (2) further comprises a soundproof panel (70) arranged in front of said intake aperture (87) of the ventilating device (12) and spaced from said intake aperture (87) by a distance comprised between 10cm and 40cm and/or a distance defined as a function of a size of the intake aperture (87) or a fan (83) diameter.

[0106] In a 97th bis aspect according to any one of the preceding aspects, the intake aperture (87) is arranged facing an entrance (100) of the building, the intake aperture (87) being interposed between the frame axis (FA) of the supporting frame (3) and an entrance central axis (ECA) orthogonal to the entrance (100) and crossing the entrance at a middle point.

[0107] In a 97th ter aspect according to the preceding aspect, an axis orthogonal to the intake aperture (87) and directed away from the frame axis (FA) of the supporting frame (3) crosses the entrance (100) or is directed towards the entrance (100).

[0108] In a 97th quater aspect according to any one of the preceding aspects from 1 to 97, the intake aperture (87) is arranged opposite to the entrance (100), the frame axis (FA) of the supporting frame (3) being interposed between the intake aperture (87) and the entrance central axis (ECA).

[0109] In a 97th quinquies aspect according to the preceding aspect, an axis orthogonal to the intake aperture (87) and directed away from the frame axis (FA) of the supporting frame (3) is directed away from the entrance (100) and in particular does not cross the entrance (100).

[0110] In a 98th aspect according to any one of the preceding aspects, the soundproof panel (70) comprises a main surface (71) arranged in front of said intake aperture (87) of the ventilating device (12), said main surface 71 being substantially perpendicular to the reference plane RP and/or to the building façade.

[0111] In a 98th bis aspect according to the preceding aspect, the soundproof panel (70) further comprises a lateral surface (72) extending transversal, in particular substantially orthogonal, from the main surface (71) of the soundproof panel (70),

[0112] in particular wherein the lateral surface (72) emerges towards the through opening (8) of said at least one modular element (1) so that the modular element (1) is substantially interposed between the lateral surface (72) and the building façade.

[0113] In a 98th ter aspect according to the preceding aspect, the lateral surface (72) and the main surface (71) of the soundproof panel (70) define a soundproof panel (70) having a L-shape.

[0114] In a 99th aspect according to any one of the preceding aspects, the air curtain barrier (2) comprises at least one support structure (90) configured to support the at least one modular element (1), in particular to support the vertical and/or the horizontal series of modular elements (1), the support structure being engaged to the at least one modular element (1) and configured to couple

to a building façade (101).

[0115] In a 100th aspect according to the preceding aspect, the soundproof panel (70) being engaged and carried by said at least one support structure and extending along a main surface facing the intake aperture (87), said main surface (71) of the soundproof panel (70) being substantially perpendicular to the reference plane (RP) and/or angularly tilted with respect to a rotation axis of the fan (83) of the ventilating device (82) by an angle comprised between 40° and 85°, in particular between 60° and 80°, more in particular between 65° and 75°, optionally wherein the main surface of the soundproof panel (70) is angularly tilted with respect to the ejection direction (S) of the at least one modular element (1) by an angle comprised between 5° and 35°, in particular between 10° and 30°, more in particular between 15° and 25°.

[0116] In a 101st aspect according to any one of the preceding aspects, the soundproof panel (70) has a rectangular or square shape and extends over a length comprised between 30cm and 80cm, over a width comprised between 30cm and 80cm, and over a thickness comprised between 2cm and 8cm, and wherein the length and the width defines the main surface of the soundproof panel (70).

[0117] A 102nd aspect is directed to an installation process of an air curtain barrier (2) comprising at least the following steps:

- providing an air curtain barrier (2) according to any one of the preceding aspects;
- positioning the air curtain barrier (2) at an entrance (100) of a building and outside said building along a façade of the building (101);
- angularly orienting the ejection direction (S) of each modular element (1) at a predefined angular orientation with respect to the facade of the building, said predefined angular orientation defining an angle included between the facade of the building and the ejection direction (S) comprised between 40° and 85°, in particular between 60° and 80°, more in particular between 65° and 75°.

BRIEF DESCRIPTION OF THE DRAWINGS

[0118] Some embodiments and some aspects of the invention will be described below with reference to the appended drawings, provided solely by way of illustration and hence not by way of limitation, in which:

- > Figures 1 and 2 are perspective top views of a modular element according to an embodiment of the present invention;
- > Figure 3 is a perspective view of a partially unmounted modular element according to an embodiment of the present invention;
- > Figures 4 and 5 are perspective bottom views of a modular element according to an embodiment of

the present invention;

> Figure 5B is a perspective view of a modular element according to an embodiment of the present invention;

> Figure 6 is a perspective view of a ventilating device engageable to a modular element according to an embodiment of the present invention;

> Figures 7 and 8 are perspective views of an air curtain barrier according to an embodiment of the present invention;

> Figure 9 is a perspective view of an air curtain barrier according to a further embodiment of the present invention;

> Figure 10 is a perspective view of an air curtain barrier installed at an entrance of a building according to an embodiment of the present invention;

> Figure 11 is a cross section view of an air curtain barrier according to an embodiment of the present invention;

> Figures 12 and 13 are perspective views of an air curtain barrier installed at an entrance of a building according to alternative embodiments of the present invention.

25 DETAILED DESCRIPTION

Modular element

[0119] Figures 1-5 show in its entirety a modular element 1 for a dynamic air curtain barrier 2, the latter being shown in figures 7-11 according to a non-limitative embodiment. The dynamic air curtain barrier 2 comprises the modular element 1 and a ventilating device shown in figure 6.

[0120] In order to better understand the structure of the modular element 1, it is useful to clarify that an air curtain barrier 2 is a system, arrangeable at an entrance 100 of a building 101 to an air-conditioned interior as shown in figure 10, which is configured to produce an air "barrier" in order to thermally insulate the interior from the conditions of the outer environment. In particular, the air curtain barrier 2 is configured to produce an air flow transversal to a façade of the building 101 at the entrance 100. The air curtain barrier 2 may be preferably installed outside the building, and wherein the air flow is directed away from the entrance 101 of the building 101 as shown in figure 11.

[0121] The air curtain barrier 2, as will be better described below, comprises a plurality of modular elements 1 connected each other one over the other and aligned along an axis of extension 1a as shown in figure 9. The appended figure 10 illustrates, in a non-limiting manner, an air curtain barrier 2 comprising four modular elements 1 aligned along a vertical direction, thereby forming a vertical column suitable for being positioned along the vertical extent of the entrance 100. Further details about alternative arrangements of the modular elements 1 to form a customizable air barrier curtain 2 are provided

later on in the description.

[0122] Each modular element 1 comprises a supporting frame 3 having, by way of non-limiting example, an elongated shape: the supporting frame 3 extends along a prevalent direction of extension D direction of extension of the modular element 1 between a first and a second longitudinal end 3a, 3b. The supporting frame 3 has a lateral wall 4 internally defining a housing compartment 5 and which defines, at the first and second ends 3a, 3b, a respective first and second longitudinal openings 6, 7. In detail, the frame 3 may have a tubular shape open at longitudinal ends, in which the first and second longitudinal openings 6, 7 are delimited by the respective first and second ends 3a, 3b having circular shape: the housing compartment 5 extends for the entire length of the modular element 1. The supporting frame is preferably made by sheet metal, such as steel, stainless steel, aluminium or the like. Alternatively, the supporting frame 3 may be made by a synthetic material, such as plastic or composite material.

[0123] The appended figures illustrate a preferred, but non-limiting embodiment of the invention wherein the supporting frame 3 has a substantially cylindrical/tubular shape extending along a frame axis FA substantially coinciding with the prevalent direction of extension D of the frame itself. In particular the first and second ends 3a, 3b, and the respective first and second longitudinal openings 6, 7 have therefore circular shape.

[0124] Alternatively, in further non-unillustrated embodiment, the supporting frame 3 may have a square, rectangular, square, elliptic, triangular shape or a combination thereof. In this case, the first and second ends 3a, 3b, and the respective first and second longitudinal openings 6, 7 are therefore counter-shaped, namely having a square, rectangular, square, elliptic, or triangular shape.

[0125] The supporting frame 3 may have a length, measured as a distance between the first and second ends 3a, 3b, comprised between 50cm and 250cm. Furthermore, the frame 3 may have, in a cross section perpendicular to the prevalent direction of extension D, a predetermined transversal dimension preferably comprised between 50cm and 150cm. As described above the frame 3 preferably has an elongated shape: the length is thus preferably greater than the transversal dimension. In particular, a ratio between the length of the frame 3 and the transversal dimension is comprised between 1.2 and 5, even more in particular between 1.5 and 3. In more detail, in the case wherein the supporting frame has tubular shape, the transversal dimension corresponds to the diameter of the supporting frame 3.

[0126] As can be seen for example from figures 1 to 5, the supporting frame 3 comprises a lateral through opening 8 substantially extending along the prevalent direction of extension D of the frame itself: the opening 8 defines a through passage in the lateral wall 4 of the frame 3 to put in fluid communication the housing compartment with the external environment.

[0127] In a preferred, but non-limiting embodiment of the invention, the lateral opening 8 extends over the entire lateral wall 4 along the prevalent direction of extension D of the frame: in particular, the lateral opening 8 may extend from the first longitudinal end 3a to the second longitudinal end 3b. By virtue of the opening 8, the frame 3 defines an open profile in a cross section transversal to the prevalent direction of extension D. The lateral opening 8 may further define a passage whose cross section remains substantially constant along the entire extent of the frame 3: for example, the opening 8 may define a passage having a substantially rectangular or square shape. According to an alternative embodiment not shown in the attached figures, the through opening 8 may define a passage whose cross section varies along the extent of the frame 3: in particular, the lateral opening 8 may define a passage section for the air flow whose size increases or decreases from the first end 3a to the second end 3b. As regards the dimensional aspect of the through opening 8, the latter may have a passage section having a predetermined area, for example comprised between 200 and 700 cm², in particular comprised between 300 and 500 cm².

[0128] The supporting frame may be connected with at least one ventilating device 12, shown singularly in figure 6 and connected to the modular element in figure 7, configured to generate an air flow destined to the housing compartment 5 of the supporting frame 3 by passing through the first and/or the second longitudinal openings 6, 7 and exiting the supporting frame 3 through the lateral through opening 8.

[0129] The modular element 1 can further comprise at least one coupling portion 26 configured to reciprocally engage modular elements 1 each other along a direction substantially coincident with the prevalent direction D of the modular elements. In other terms, the coupling portions 26 allow the modular elements 1 to be aligned along an axis 1a substantially rectilinear. The coupling portion 26 may further allow to arrange the modular elements 1 in a plurality of operative positions each defined by an angular orientation with respect to one another, the angular orientation being referred to the direction S of ejection of the air flow: in particular the through openings 8 of each modular element may be angularly oriented according to a customized angular orientation. However, in a preferred embodiment as described later on in more detailed, a series of modular elements 1 have the through openings 8 of the modular elements aligned along a common rectilinear direction substantially parallel to the prevalent direction D of each modular element: in other terms the through openings 8 are equally angularly oriented. The coupling portion 26 may comprise a predetermined number of elements, optionally protruding axially along the prevalent direction D, configured to cooperate with a respective predetermined number of axial recesses of a coupling portion 26 of an adjacent modular element 1.

[0130] The modular element 1 further comprises at least one manifold 9 arranged within the housing com-

partment 5 of the supporting frame 3. The manifold 9 comprises a manifold lateral wall 10 engaged with the supporting frame 3 and extending substantially along the prevalent direction D of the supporting frame 3 between a first and a second end edges 11, 12. The manifold 9 may be engaged with the supporting frame 3 by welding, bolt couplings, rivets or interlocking couplings. The manifold 9 may be made by a sheet metal, such as steel, stainless steel, aluminium, plastic or a composite material. The manifold 9 comprises a first and a second axial openings 17, 18 respectively defined, at least partially, by the first and the second end edges 11, 12: the first and the second axial openings 17, 18 are configured to receive the air flow from a ventilating device 12 along a direction substantially parallel to the prevalent direction D of extension of the supporting frame 3. The manifold defines an internal passage volume 22 at least partially laterally delimited by the manifold lateral wall 10 and by the first and second axial openings 17, 18. Furthermore, the manifold lateral wall 10 comprises a lateral through opening 15 fluidly connecting the internal passage volume 22 of the manifold 9 with the lateral through opening 8 of the supporting frame 3, so that the air flow is allowed to pass through the first and/or the second longitudinal openings 6, 7, enter into the internal passage volume 22 through the first and/or the second axial openings 17, 18 of the manifold lateral wall 10, and exit from the housing compartment 5 through the lateral through opening 15 of the manifold lateral wall 10 and the lateral through opening 8 of the supporting frame 3 along a direction S of ejection. In other terms, the lateral through opening 8 of the supporting frame 3 and the lateral through opening 15 of the manifold lateral wall 10 are coincident. The manifold lateral wall 10 preferably comprises a first and a second manifold lateral walls 10a, 10b as shown in figures 3, 4 and 5, having at least a portion converging each other between a first section of minimum distance D_{min} and a second section of maximum distance D_{max} . Notably, the second section of the manifold lateral wall 10 is opposite to the lateral through opening 8 of the supporting frame 3 with respect to the prevalent direction D of the supporting frame 3.

[0131] In particular, the converging portion defines an angle in between the first and a second manifold lateral walls 10a, 10b comprised between 20° and 120° , in particular between 30° and 90° , more in particular between 40° and 70° . Furthermore, a ratio between the maximum distance D_{max} and the minimum distance D_{min} respectively of the second and first section of manifold wall 10 may be greater than 2, in particular it may be comprised between 3 and 10. De facto, the openings 17, 18 defined by the manifold lateral wall 10 have substantially a trapezoidal shape, in particular a rectangular trapezoidal shape.

[0132] According to a non-shown embodiment, the first and the second manifold lateral walls 10a, 10b are entirely converging each other between the first and the second sections D_{min} , D_{max} , so that the first and the

sections are engaged to the supporting frame of the modular element and wherein the first section defines the lateral through opening 15 arranged at the through opening 8 of the supporting frame 3. Preferably, the first and the second manifold lateral walls 10a, 10b define respective plane walls converging each other between the first section of minimum distance D_{min} and the second section of maximum distance D_{max} .

[0133] In an another embodiment shown in the attached figures, the manifold lateral wall 10 further comprises a parallel portion extending between an end of the converging portion of the manifold wall and the supporting frame at the through opening 15. In the parallel portion, the first and the second manifold lateral walls 10a, 10b are parallel each other, extending both along the prevalent direction D and in depth inwards the housing compartment 5. Both the converging portion and the outlet parallel portion of the manifold 9 are entirely arranged within the housing compartment 5 of the supporting frame 3. The parallel portion defines a through opening 15 having rectangular parallelepiped shape extending in depth from the supporting frame to the end of the converging portion of the manifold wall, and in length between the first and the second end edges 11, 12 of the manifold wall 10. In more detail, the rectangular parallelepiped shape has a length directed as the prevalent direction D of the supporting frame 3, a width orthogonal to the length and defining, in combination with the length, an outlet section (coincident with the through opening 15) configured to allow the air flow to exit the housing compartment 5, and a depth extending internally the housing compartment 5 starting from an external surface of the lateral wall 4 of the supporting frame 3. The depth may be comprised between 5cm and 25cm and/or may be set as a function of the length and/or of the width of the parallel portion. Preferably the depth of the parallel portion is higher than the width, with the depth being 10% to 300% higher than the width, in particular said depth being 50% to 100% higher than the width of the through opening 15.

[0134] Notably, the internal passage volume 22 is the combination of an internal volume delimited by the converging portion, plus an internal volume delimited by the parallel portion. In particular the parallel portion may provide aerodynamic advantages in the air flow exiting the modular element 1. In this embodiment, the converging portion of the lateral wall 10 defines a cross section having a trapezoidal shape. Furthermore, the outlet parallel portion of the manifold 9 may extend between the outlet edge to the end of the converging portion by a length comprised 5% and 40% of the diameter of the supporting frame 3, in particular between 10% and 30% of the diameter of the supporting frame 3.

[0135] As shown in figures 3, 4 and 5, the first manifold lateral wall 10a extends along the prevalent direction D of the supporting frame 3 between a respective first end edge 11a and a respective second end edge 12a. Analogously, the second manifold lateral wall 10b extends along the prevalent direction D of the supporting frame

3 between a respective first end edge 11b and a respective second end edge 12b. A portion of the first end edge 11a of the first manifold lateral wall 10a is convergent, in particular transversal, to a respective portion of the first end edge 11b of the second manifold lateral wall 10b. Analogously, a portion of the second end edge 12a of the first manifold lateral wall 10a is convergent, in particular transversal, to a respective portion of the second end edge 12b of the second manifold lateral wall 10b.

[0136] According to a non-shown embodiment, the first end edge 11a of the first manifold lateral wall 10a is entirely convergent, in particular transversal, to the first end edge 11b of the second manifold lateral wall 10b. Analogously, the second end edge 12a of the first manifold lateral wall 10a may be entirely convergent, in particular transversal, to the second end edge 12b of the second manifold lateral wall 10b.

[0137] Furthermore, the first manifold lateral wall 10a extends transversal, in particular orthogonal, to the prevalent direction D of the supporting frame 3 between a first outlet edge 13a and a first inner edge 14a. Analogously, the second manifold lateral wall 10b extends transversal, in particular orthogonal, to the prevalent direction D of the supporting frame 3 between a second outlet edge 13b and a second inner edge 14b. The first outlet edge 13a and the second outlet edge 13b may be substantially parallel each other and distanced by the minimum distance D_{min} . The first and the second outlet edges 13a, 13b are engaged to the lateral wall 4 of the supporting frame 3. In addition, the first inner edge 14a and the second inner edge 14b may be substantially parallel each other and distanced by the maximum distance D_{max} . The first and second inner edges 14a, 14b are also engaged to the lateral wall 4 of the supporting frame 3. In a preferred embodiment, the first outlet edge 13a, the first inner edge 14a, the second outlet edge 13b and the second inner edge 14b are substantially parallel each other. In further detail, the first and the second outlet edges 13a, 13b may be opposite to the first and the second inner edges 14a, 14b with respect to the prevalent direction D of the supporting frame 3, in particular with respect to the axis of the tubular body of the supporting frame 3.

[0138] Notably, the distance between the first outlet edge 13a and the second outlet edge 13b defines the width of the through opening 15 and the width of the parallel portion of the manifold 9. In particular the first and the second outlet edges 13a, 13b respectively of the first and second manifold walls 10a, 10b define at least partially the through opening 15 of the manifold wall 10 of the manifold 9. Thus, the through opening 15 of the manifold wall 10 defines an outlet section having a rectangular shape with a length directed as the prevalent direction D of the supporting frame 3 and a width orthogonal to this length. The length of the through opening 15 is substantially equal to the length of the supporting frame, and to the length of the manifold, wherein these lengths are measured parallel to the prevalent direction D. In more detail, the width of the through opening 15 may be com-

prised between 3cm and 15cm and/or may be set as a function of the length, for example wherein the width is comprised between 1% and the 20% of the length, in particular more than 2%-3%, and more in particular between 3% and the 10%. The length of the through opening 15 may be comprised between 50cm and 250cm. The depth of the through opening 15 may be comprised between 5cm and 20cm.

[0139] The manifold 9 may also comprise a plurality of flaps 60 arranged at the through opening 15 and configured to deflect or channel the air flow exiting the modular element 1. Notably, the plurality of flaps reduces an outlet section of the through opening 15, thereby increasing the speed of the air flow at the exit. The manifold 9 may comprise a number of flaps 60 comprised between 4 and 25, more in particular between 8 and 15, more in particular between 10 and 12. The plurality of flaps 60 may be optionally mountable on and removable from the modular element 1 from the outside the housing compartment 5, and wherein the modular element is configured to house a variable number of flaps 60. The fact that the flaps 60 may be mountable on and removable from the modular element 1 from the outside the housing compartment 5, instead of from the inside, make the mounting and removal operations easier and faster. In particular, an assembly may be provided and comprising a modular element 1 and a plurality of flaps 60 mountable at the through opening 15 of the manifold 9 and configured to deflect or channel the air flow exiting the modular element 1. The mountable flaps may be selectable between different thickness values: a variation of the flap thickness will affect an outlet section of the through opening 15, thereby varying the speed of the air flow at the exit. As in the embodiment shown in the attached figures but not limiting to the latter, the lateral opening 8 of the supporting frame 3, and the lateral through opening 15 of the manifold 9, extend over the entire lateral wall 4 of the supporting frame 3 along the prevalent direction D of extension. In particular the lateral opening 8 extends from the first longitudinal end 3a to the second longitudinal end 3b of the supporting frame 3 so as to define a through opening 8 which puts the external environment in fluid communication with the housing compartment 5.

[0140] Analogously, the manifold wall 10 may extend over the entire lateral wall 4 of the supporting frame 3 along the prevalent direction D of extension. In particular the manifold wall 10 of the manifold 9 may extend over the entire lateral wall 4 of the supporting frame 3 along the prevalent direction D of extension between the first and the second longitudinal ends 3a, 3b of the supporting frame 3. Alternatively, the manifold 9 may extend along the prevalent direction D by a length lower than a respective length of the supporting frame, so that at least one between the first and a second end edges 11, 12 of the manifold wall 10 are completely laterally surrounded by the lateral wall 4 of the supporting frame 3 and inserted within the housing compartment 5.

[0141] The modular element further comprises a

soundproofing element 40 arranged in a soundproof volume 41 within the housing compartment 5 of the supporting element and configured to absorb at least partially a noise or vibration generated by the ventilating device 12 and by the air flowing within the modular element. The soundproofing element 40 is schematically shown in figure 5B and may comprise rock wool, cork, wood fiber, hemp, jute, rubber, foam in particular polyurethane or polyethylene foam, cotton or cotton fibres.

[0142] Optionally the soundproofing element 40 is made by a fibrous or a foam based material having a density comprised between 30 and 150kg/m³. The soundproof volume 41 is interposed between the manifold lateral wall 10 of the manifold 9 and the lateral wall 4 of the supporting frame 3, and it is preferably filled entirely by the soundproofing element 40. In particular the soundproofing element 40 extends from the first end edge 11a to the second end edge 12a of the manifold lateral wall 10 and contacts an inner surface of the lateral wall 4 of the supporting frame 3 and an outer surface of the manifold lateral wall 10.

[0143] As shown in the embodiment of figures 3, 4 and 5, the housing compartment 5 comprises a first and a second soundproof volumes 41a, 41b housed within the housing compartment 5 of the supporting frame 3: the internal passage volume 22 is interposed between the first and the second soundproof volumes 41a, 41b with respect to a direction orthogonal to the prevalent direction D of the supporting frame 3. In particular, the first and the second soundproof volumes 41a, 41b may preferably have volume and shape equal each other. Thus, the first and the second manifold walls 10a, 10b, and therefore at least part of the internal volume 22, are separated with respect to a portion of the lateral wall 4 of the supporting frame 3 by the soundproofing element.

[0144] In an embodiment, the first and the second longitudinal openings 6, 7 fluidly communicates with both the internal passage volume 22 and the soundproof volume 41: in particular the first and the second longitudinal openings 6, 7 may fluidly communicate with the internal passage volume 22 and the first and the second soundproof volumes 41a, 41b, so that an amount of air flow coming from the ventilating device 12 is allowed to enter, at least partially, in the soundproof volume.

[0145] In an embodiment shown in figure 2 and 3, the internal passage volume 22 is laterally delimited by the first and the second manifold walls 10a, 10b, and by a portion of the lateral wall 4 of the supporting frame: thus the first and the second soundproof volumes 41a, 41b only partially surround the internal passage volume 22, as this portion of the lateral wall 4 of the supporting frame is not shielded by the soundproofing element 40.

[0146] In a further embodiment shown in figures 4 and 5, the manifold lateral wall 10 further comprises a third manifold lateral wall 10c arranged within the housing compartment 5 and extending along the prevalent direction D. The third manifold lateral wall 10c is interposed between the first manifold lateral wall 10a and the second

manifold lateral wall 10b and coupled to both the latter. In particular the third manifold lateral wall 10c connects the first manifold lateral wall 10a with the second manifold lateral wall 10b. The third manifold lateral wall 10c is arranged opposite to the through opening 15 of the manifold 9 with respect to the prevalent direction D, in particular with respect to the frame axis of the tubular supporting frame: in more detail, the third manifold lateral wall 10c is arranged closer to an inner surface of the lateral wall 4 of the supporting frame 3 than to the through opening 15. Thus, according to this embodiment comprising the third manifold wall 10c, the internal passage volume 22 is laterally delimited entirely by the first, the second and the third lateral walls 10a, 10b, 10c. The axial openings 17, 18 of the manifold are thus defined by the first, the second and the third manifold walls 10a, 10b, 10c. Furthermore, the third manifold lateral wall 10c defines a third soundproof volume 41c interposed between the third manifold lateral wall 10c itself and a portion, facing the third manifold lateral wall 10c, of the lateral wall 4 of the supporting frame 3. In addition the third soundproof volume 41 is also delimited by inner end portions of the first and the second manifold lateral walls 10a, 10b: in particular these inner end portions of the first and the second manifold lateral walls 10a, 10b comprise the first and the second inner edges 14a, 14b, the latter being engaged to the lateral wall of the supporting frame 3. Notably the internal passage volume 22 is separated from the third soundproof volume 41c by the third manifold lateral wall 10c. The third soundproof volume 41c may also house the soundproofing element 40 in order to further reduce the noise. In this way, the internal volume 22 is entirely surrounded by soundproofing element 40, except for the through opening 15. Alternatively the third soundproof volume 41c may be empty, without being filled with the soundproofing element 40. Air in the third soundproof volume 41c in this case may be sufficient to isolate from noise the external environment.

[0147] As shown in the figures 4 and 5, the first soundproof volume 41a is separated from the third soundproof volume 41c by the inner end portion of the first manifold lateral wall 10a, and the second soundproof volume 41b is divided from the third soundproof volume 41c by the inner end portion of the second manifold lateral wall 10b. Thus, the third soundproof volume 41c is directly interposed between the first and the second soundproof volumes 41a, 41b. Notably, in an additional embodiment, the modular element 1 may comprise further soundproof volumes containing the soundproofing element. The third manifold lateral wall 10c is engaged to the first and the second manifold walls 10a, 10b by respective folded end portions, i.e. a first folded end portion engaged to the first manifold wall 10a and a second folded end portion engaged to the second manifold wall 10b, which face respectively the first and the second manifold walls 10a, 10b. In particular the respective folded end portions of the third manifold lateral wall 10c are substantially parallel to respective first and second manifold walls 10a,

10b, as shown in figures 4, 5 and 6. The folded end portions of the third manifold lateral wall 10c may be welded to the first and the second manifold walls 10a, 10b.

[0148] According to the embodiment of figures 4 and 5, the folded end portions of the third manifold lateral wall 10c extend towards the lateral wall 4 of the supporting frame 3, so that the folded end portions are within the third soundproof volume 41c.

[0149] In an alternative embodiment, the folded end portions of the third manifold lateral wall 10c are arranged within the internal passage volume 22, thereby allowing to move the third manifold lateral wall 10c towards the lateral wall 4 of the supporting frame 3, thus increasing the extension of the internal passage volume 22.

[0150] As shown in figure 1, 2 and 3, the modular element 1 may further comprise a cover cap 50 arranged partially or entirely within the housing compartment 5. The cover cap 50 extends transversal, i.e. orthogonal, to the prevalent direction D of the supporting frame 3 to cover the soundproof volume 41 and the soundproofing element 40. In particular the cover cap 50 is configured to limit an amount of, or completely prevent, the air flow coming from the ventilating device 12 to enter the soundproof volume 41. In detail the cover cap 50 extends between the first and/or the second end edges 11, 12 of the manifold 9 and a portion of the lateral wall 4 of the supporting frame 3. The cover cap 50 may thus have a perimetral edge comprising a first segment having substantially the same length and shape of the end edge 11, 12 of the manifold lateral wall, and a second segment having the same length and shape of the end lateral wall 4 of a portion the supporting frame. In particular the first segment of the cover cap may have a rectilinear shape, while the second segment may have a semi-circular shape having the same diameter of the tubular supporting frame 3.

[0151] The modular element 1 may preferably comprise a first and a second cover cap 50a, 50b, wherein the first cover cap 50a is arranged as a cover of the first soundproof volume 41a and the second cover cap 50b is arranged as a cover of the second soundproof volume 41b. In particular, the first and the second cover caps may also cover, in addition to the first and the second soundproof volumes 41a, 41b, the third soundproof volume 41c. Optionally the modular element 1 may comprise a third cover cap 50c, distinct from the first and the second cover caps 50a, 50b, arranged as a cover of the third soundproof volume 41c.

[0152] In more detail, the first cover cap 50a may comprise a first upper cover cap 50a' arranged at the first end edge 11a of the manifold wall 10, and a first lower cover cap 50a" arranged at the second end edge 12a of the manifold wall 10. Thus the first upper cover cap 50a' and the first lower cover cap 50a" longitudinally delimit the first soundproof volume 41a along the prevalent direction D. Analogously, the second cover cap 50b may comprise a second upper cover cap 50b' arranged at the first end edge 11a of the manifold wall 10, and a second lower

cover cap 50b" arranged at the second end edge 12a of the manifold wall 10. Thus the second upper cover cap 50b' and the second lower cover cap 50b" longitudinally delimit the second soundproof volume 41b along the prevalent direction D. Furthermore, the third cover cap 50c may also comprise a third upper cover cap 50c' arranged at the first end edge 11a of the manifold wall 10, and a third lower cover cap 50c" arranged at the second end edge 12a of the manifold wall 10. Thus the third upper cover cap 50c' and the third lower cover cap 50c" longitudinally delimit the third soundproof volume 41c along the prevalent direction D. According to an embodiment, the cover cap 50, in particular the first and the second cover caps 50a, 50b and optionally also the third cover cap 50c, defines a closed surface which prevents, during operation of the modular element, the air to pass through the cover cap 50. Alternatively, the cover cap 50, in particular the first and the second cover caps 50a, 50b and optionally also the third cover cap 50c, may define a surface having through holes 51 configured to allow, at least partially, the air flow from the ventilating device 12 to cross the cover cap 50 and enter the soundproof volume 41. Notably, a maximum size of the through holes 51 is "n"-times lower than a respective size of the first and/or of the second axial openings 17, 18 of the manifold 9: in particular the "n" term may be comprised between 3 and 1000, more in particular between 10 and 500. In other terms, the size of the through holes 51 of the cover cap 50 are way smaller than the size of the axial openings 17, 18 of the manifold 9, in order to channel the most of the air flow into the internal passage volume 22 of the manifold 9. In particular, in a specific embodiment, the first and/or the second axial openings 17, 18 of the manifold 9 are not covered or obstructed by a cover, so that the air flow coming from the ventilating device 12 is configured to freely enter the internal passage volume 22 directly, wherein the internal passage volume 22 is in direct fluid communication with the ventilating device 12. The term "*direct*" may refer to an absence of a cover or a filter media interposed between the ventilating device 12 and the internal passage volume 22. Notably, through holes 20 may also be provided on the manifold walls 10, so that the soundproof volume 41 is in fluid communication with the internal passage volume 22. However, the expression "*in fluid communication*" should be interpreted taking into account that the soundproof volume 41 houses the soundproofing element 40, which de facto slows down or even stops the air flow, despite the presence of the through holes 20. In particular a maximum size of these through holes 20 is preferably "n"-times lower than a respective size of the first and/or the second axial openings 17, 18 of the manifold 9, wherein the "n" term is comprised between 3 and 1000, more in particular between 10 and 500. The through holes 20 of the manifold lateral wall 10, in particular of the first and second manifold lateral walls 10a, 10b, may be manufactured by an expanded metal process. The expanded metal process comprises the steps of performing a plu-

rality of through cuts in the manifold lateral wall 10 wherein the through cuts extend substantially along a first direction, and subsequently stretching the manifold lateral wall 10 along a second direction substantially orthogonal to said first direction. The expanded metal process leads to through holes 20 having a substantially rhomboidal shape.

[0153] In an alternative embodiment, the manifold walls 10 defines an air-tight closed-loop lateral surface, wherein gas passage through the manifold lateral wall 10 between the internal passage volume 22 and the soundproof volume 41 is prevented. Analogously, also the cover cap 50 may define an air-tight closure so that air flow in the soundproof volumes 41 is prevented.

[0154] According to an embodiment, the soundproofing element 40 may comprise a panel 40a made of, for example, rock wool or alternatively cork, wood fiber, hemp, jute, rubber, polyurethane or polyethylene foam, cotton or cotton fibres: the panel 40a is arranged in the first and second soundproof volumes 41a, 41b and faced, in particular in contact, with the first and second manifold walls 10a, 10b. The panel 40a may be counter shaped to the first and second manifold walls 10a, 10b so that the panel covers the entire surface of the manifold walls 10a, 10b. The panel 40a may also comprise a plasticized or partially plasticized surface to improve mechanical resistance of the panel during handling (namely during manufacturing of the modular element) and during an operational phase of the modular element 1. The panel defines a compact element having a defined and regular shape. The panel 40a may be also arranged in the third soundproof volume 41c: alternatively, the third soundproof volume 41c may be empty. Furthermore, the soundproofing element 40 may be in a shape of shavings 40b as schematically shown in figure 5B, i.e. shavings of rock wool or cork, wood fiber, hemp, jute, rubber, foam in particular polyurethane or polyethylene foam, cotton or cotton fibres, or a combination thereof. In this case the shavings 40b, contrary to the panel 40a, have a random and irregular shape, with different sizes as well. Thus the panel 40a arranged at the manifold wall 10, in particular at both the first and second manifold walls 10a, 10b, prevents the shavings 40b to pass through the through holes 20 of the manifold wall 10. Furthermore, the use of shavings 40b, combined with the panel 40a, provides a good soundproofing efficiency and also reduces the manufacturing costs of the modular element 1. The shavings 40b may be also arranged in the third soundproof volume 41c: alternatively, the third soundproof volume 41c may be empty. In particular, in the case the third soundproof volume 41c is filled with shavings 40b, the third manifold lateral wall 10c is a closed wall, without through holes 20.

Air curtain barrier

[0155] The present disclosure also refers to an air curtain barrier 2 as shown in figures 7-10. The air curtain barrier 2 comprises at least one modular element 1 pre-

viously described and at least one ventilating device 12 connected to the modular element 1 and configured for generating and delivering the air flow to the housing compartment 5 of the supporting frame 3. The at least one modular element 1 is configured for receiving the air flow from the ventilating device 12 and channelling it outside the through opening 8 along the ejection direction S.

[0156] The air curtain barrier 2 may comprise one modular element 1 and one ventilating device 12 as shown in figure 8. Furthermore, the air curtain barrier 2 may comprise a first and a second modular elements 1 and one ventilating device 12 as shown in figure 9, wherein the first and the second modular elements 1 and the ventilating device 12 are coupled each other along a prevalent axis of extension 1a parallel to the prevalent direction D of the supporting frames 3 of the first and of the second modular elements. In particular the prevalent direction D of the supporting frame 3 of the first modular element coincides with the prevalent direction D of the supporting frame 3 of the second modular element: in more detail, the axis of the tubular supporting frame 3 of the first modular element coincides with axis of the tubular supporting frame 3 of the second modular element, and wherein these axis also coincides with the prevalent axis of extension 1a of the air curtain barrier 2. In this embodiment, the ventilating device 12 is interposed between the first and the second modular elements 1 along the prevalent axis of extension 1a. In general, the air curtain barrier 2 may comprise a series of modular elements 1 reciprocally engaged with each other and consecutively located along the prevalent axis of extension 1a parallel to the prevalent direction D of extension of each modular element 1. An operative position of a through opening 8 of at least one modular element 1 may be angularly adjustable about the development axis 1a with respect to an operative position of another lateral outlet opening 8 of a different modular element 1. In the case of a series or plurality of modular elements, one ventilating device 12 may be configured for generating and delivering the air flow to the housing compartments 5 of each of the modular elements 1. Alternatively, two or more ventilating device 12 may be provided and interposed between modular elements as shown in figure 10, wherein each ventilating device is configured to deliver the air flow to one or two adjacent modular elements. As in the embodiment of figure 10, the air curtain barrier 2 may comprise at least one vertical series of modular elements 1 arranged along a substantial vertical direction V one over the other and along the prevalent direction D of each supporting frame 3. The vertical series of modular elements 1 preferably define a substantially rectilinear structure along the vertical direction V. The vertical series of modular elements 1 have preferably a total height, measured from the ground, comprised between 2m and 10m.

[0157] The air curtain barrier 2 may comprise, in addition or alternatively to the vertical series of modular elements 1, at least one horizontal series of modular elements 1, not shown in figure 10, arranged along a sub-

stantial horizontal direction and along the prevalent direction D of each supporting frame 3. Preferably, the horizontal series of modular elements 1 define a substantially rectilinear structure along the horizontal direction. According to an embodiment, the air curtain barrier 2 may comprise two lateral vertical series of modular elements 1 spaced each other and arranged at opposite sides of a building entrance 100, and one horizontal series of modular elements arranged above the building entrance 100, defining an air curtain barrier 2 having a "C" shape. The two vertical series of modular elements 1 may be substantially parallel each other and separated by a distance W comprised between 1m and 8m, in particular between 2m and 4m. The horizontal series of modular elements may have a total length comprised in the same range of the W distance. Optionally, the vertical and the horizontal series of modular elements may be consecutive each other and in fluid communication, so that a single ventilating device may serve both the vertical and the horizontal device. Alternatively, distinct ventilating devices may be provided for each vertical and horizontal series of modular elements 1.

[0158] According to an embodiment wherein the air curtain barrier comprises the first vertical series of modular elements 1 and the second vertical series of modular elements 1, the first vertical series of modular elements 1 and the second vertical series of modular elements 1 may lie on a common reference plane RP, wherein this reference plane RP simultaneously crosses the vertical direction of the first and second vertical series. According to a further embodiment wherein the air curtain barrier comprises one vertical series of modular elements 1 and the horizontal series of modular elements 1, the vertical series of modular elements 1 and the horizontal series of modular elements 1 may lie on a common reference plane RP, wherein this reference plane RP simultaneously crosses the vertical direction of the first and second vertical series.

[0159] According to a still further embodiment wherein the air curtain barrier comprises the first vertical series of modular elements 1, the second vertical series of modular elements 1 and the horizontal series of modular elements 1, a common reference plane RP may simultaneously cross the vertical directions of the first and of the second vertical series, and the horizontal direction of the horizontal series of modular elements 1. The reference plane may be used to define an orientation of the ejection direction S of each modular element 1 with respect to said reference plane RP: the angular orientation defines an angle α included between the reference plane RP and the ejection direction S comprised between 40° and 85° , in particular between 60° and 80° , more in particular between 65° and 75° .

[0160] According to a preferred further embodiment, the ejection direction S of the modular elements 1 of the vertical series are angularly oriented in the same direction: thus, all the modular elements of the series eject the air flow along the same direction.

[0161] Alternatively, according to a further embodiment, the orientation of the ejection direction S of the modular elements 1 of the vertical series may vary with a distance of the modular element with respect to the ground, namely the height of the modular element: in particular the angular orientation of the ejection direction S may increase within the above mentioned range with the distance of the modular element with respect to the ground. Notably, the ejection direction S of a modular element may be defined as a direction orthogonal to an outlet section of the through opening 15 of the manifold 9. Analogously, the ejection direction S of a modular element may be defined as a direction crossing orthogonally the through opening 15 of the manifold and passing through the central axis of the tubular supporting frame 3. In a working condition, the ejection direction S coincides with the main direction of the air flow exiting the modular element.

[0162] The ventilating device 12, shown in detail in figure 6, comprises a motor frame 80 defining an internal volume 81, a motor 82, in particular an electric motor, arranged within the internal volume 81 of said motor frame 80, and at least one fan 83 coupled to the motor 82. The motor 82 is configured to rotate the fan 83 to generate the air flow towards said modular elements. The motor frame 80 comprises a lateral wall 84 extending longitudinally between a first and a second edges 85, 86 which define respectively a first and a second through openings 85a, 85b configured to allow the air flow generated by the fan to pass through. In particular the motor frame 80 may have a tubular shape defining an axis substantially aligned, when the motor frame is coupled to the modular element, with the prevalent direction D of this modular element 1. The first and the second edges 85, 86 of the motor frame 80 are configured to be engaged to the modular elements 1, so that the first and the second through openings 85a, 86a of the motor frame 80 are faced and coincident with the first and/or the second longitudinal openings 6, 7 of the supporting frame 3 of a modular element. The fan is configured to rotate about a rotation axis, optionally coincident with a rotation axis of the motor, transversal or orthogonal to the prevalent direction D of the modular elements 1. The fan 83 may be a centrifugal, as the one shown in figure 6, or a radial or an axial fan: a centrifugal fan determines an air flow, within the motor frame, directed orthogonally to the rotation axis of the fan. According to a preferred embodiment, the rotation axis of the fan of the ventilating device 12 is orthogonal to the ejection direction S of the modular element 1 and to the axis of the motor frame. Analogously, the rotation axis of the fan of the ventilating device 12 may be orthogonal to the ejection direction S of the modular element 1 and to the prevalent direction D of the modular element 1.

[0163] The air curtain barrier 2 also comprises support structures 90, shown in figure 10, configured to support the modular elements 1. For example, one support structure may be provided to support each modular element

1 of the vertical and/or the horizontal series of modular elements 1. The support structure is engaged to the modular element 1 and configured to be coupled to a building façade 101.

[0164] The ventilating device 12 further comprises an intake aperture 87, shown in figure 6, configured to promote air to the fan 83: a net or a grid may be provided at the intake aperture 87 in order to allow the air to enter the motor frame and to increase safety. The intake aperture 87 may be arranged facing the entrance 100, as shown in figures 10 and 11, so that the intake aperture 87 is interposed between the frame axis FA of the supporting frame 3 and the entrance central axis ECA orthogonal to the entrance 100 and crossing the entrance at a middle point. In this case, an axis orthogonal to the intake aperture 87 and directed away from the frame axis FA of the supporting frame 3 may cross the entrance 100 or be directed towards the entrance 100. Alternatively, the intake aperture 87 may be arranged opposite to the entrance 100 as shown in figures 12 and 13, so that the frame axis FA of the supporting frame 3 is interposed between the intake aperture 87 and the entrance central axis ECA. In this case, an axis orthogonal to the intake aperture 87 and directed away from the frame axis FA of the supporting frame 3 does not cross the entrance 100 and is directed away from the entrance 100. The embodiment wherein the intake aperture 87 is arranged opposite to the entrance 100 allows the noise, generated by the fan, to be directed away from the entrance, reducing thereby the acoustic pollution which a person entering the entrance 100 is subjected to.

[0165] A soundproof panel 70 may be arranged in front of the intake aperture 87 of the ventilating device 12 in order to absorb, at least partially, a noise generated by the ventilating device. The panel 70 may be arranged at a distance from the intake aperture 87 comprised between 10cm and 50cm. This distance may be also defined as a function of a size of the intake aperture 87 or as a function of a diameter of the fan 83. The soundproof panel 70 may have a rectangular or square shape, extending over a length comprised between 30cm and 60cm, over a width comprised between 30cm and 60cm, and over a thickness comprised between 2cm and 8cm. The length and the width of the panel 70 define a main surface 71 of the soundproof panel. Alternatively, the soundproof panel may also have a circular shape, preferably having a diameter equal or bigger than a size, i.e. a diameter, of the intake aperture 87. In this case the main surface 71 of the soundproof panel 70 is defined by the diameter of the soundproof panel 70. In particular, the soundproof panel 70 may be engaged and carried by the support structure 90 and mounted so that the main surface 71 of the soundproof panel 70 is substantially perpendicular to the reference plane RP previously defined. Analogously, the main surface 71 of the soundproof panel 70 is not perpendicular to the rotation axis of the fan 83 of the ventilating device 12: in more detail, the rotation axis of the fan 83 of the ventilating device 12

defines an angle α with the main surface 71 of the soundproof panel 70 comprised between 40° and 85°, in particular between 60° and 80°, more in particular between 65° and 75°. In general terms, the main surface 71 of the soundproof panel is angularly tilted with respect to the rotation axis of the fan 83 by an angle α equal to the angle α included between the reference plane RP and the ejection direction S. Furthermore, the main surface 71 of the soundproof panel 70 may be angularly tilted with respect to the ejection direction S of the modular element 1 by an angle β comprised between 5° and 35°, in particular between 10° and 30°, more in particular between 15° and 25°. Notably, the angle β is complementary to the angle α .

[0166] According to a further embodiment, the soundproof panel 70 further comprises a lateral surface 72 extending transversal, in particular substantially orthogonal, from the main surface 71 of the soundproof panel 70 as shown in figure 13. The lateral surface 72 emerges towards the through opening 8 of the respective modular element 1: notably the modular element 1 is substantially interposed between the lateral surface 72 and the building façade with respect to a direction orthogonal to the building façade. Thus, the lateral surface 72 and the main surface 71 of the soundproof panel 70 define a soundproof panel 70 having an L-shape. The lateral surface 72 may extend in surface as the main surface: alternatively the lateral surface 72 of the soundproof panel 70 may be smaller in size than the main surface. Notably, the lateral surface 72, although it emerges from an edge of the main surface 71 towards the through opening 8 of the respective modular element 1, does not cover the through opening 8, so that the air flow is allowed to freely spread. Figure 13 shows the L-shaped soundproof panels 70 arranged outwardly with respect to the entrance 100, so that the modular elements 1 are interposed between the panels 70 and the entrance 100 with respect to a horizontal direction.

[0167] In the embodiment of figure 13, the intake aperture 87 of the ventilating device 12 is faced outwardly with respect to the entrance 100, in order to guide/direct the noise away from the entrance as mentioned before: however, the L-shape panels 70 are not limited to this embodiment but may also be used when the intake apertures 87 of the ventilating device 12 are faced inwardly with respect to the entrance 100, so that the panels 70 are interposed between the modular elements 1 and the entrance 100 with respect to a horizontal direction. Notably, when the intake aperture 87 of the ventilating device 12 is faced outwardly with respect to the entrance 100 as in figures 12 and 13, the lateral surface 72 of the L-shape panel 70 extends from the main surface 71 towards the entrance 100: on the contrary, when the intake aperture 87 of the ventilating device 12 is faced towards the entrance 100 as in figures 10 and 11, the lateral surface 72 of the L-shape panel 70 extends from the main surface 71 away with respect to the entrance 100.

Installation process

[0168] The present disclosure also refers to an installation process of an air curtain barrier according to the preceding disclosure. The installation process comprises at least the following steps:

- providing at least one modular element 1 according to the preceding description;
- providing at least one ventilating device 12;
- coupling the at least one modular element with the at least one ventilating device 12 along an axis of extension 1a substantially parallel or coincident to the prevalent direction D of the supporting frame of the at least one modular element 1. This coupling step defines the air curtain barrier 2 according to the previous description.

[0169] The installation process may also comprise orienting the ejection direction S of the modular elements along a desired direction: in particular the installation process may comprise the following steps: providing the air curtain barrier 2; positioning the air curtain barrier 2 at an entrance 100 of a building 101 and outside the building along a façade of the building 101, in particular the air curtain barrier 2 surrounding at least partially the entrance 100 along a vertical and/or a horizontal direction; angularly orienting the ejection direction S of each modular element 1 at a predefined angular orientation with respect to the facade of the building, the predefined angular orientation defining an angle α included between the facade of the building and the ejection direction S comprised between 40° and 85° , in particular between 60° and 80° , more in particular between 65° and 75° . In particular the angle α is comprised between the entrance 100 and the ejection direction S. Thus, the air flow is directed away from the entrance and towards an entrance central axis ECA orthogonal to the entrance and crossing the entrance at a middle point. Notably, the air curtain barrier 2 are preferably installed outside the building: the ejection direction S of the air flow is directed outwardly, namely along a direction from the building façade and away from the building façade.

Claims

1. A modular element (1) for dynamic air curtain barriers (2), said modular element (1) comprising:

- at least one supporting frame (3) extending along a prevalent direction (D) of extension between a first and a second longitudinal ends (3a, 3b), said supporting frame (3) having a lateral wall (4) internally defining a housing compartment (5) and which defines, at the first and second ends (3a, 3b) of the supporting frame (3), a respective first and second longitudinal open-

ings (6, 7), the first and second longitudinal openings (6, 7) being delimited by respective free edges (6a, 7a),

the supporting frame (3) further comprising at least one lateral through opening (8) substantially extending along the prevalent direction (D) of extension of the supporting frame, the supporting frame (3) being associable with at least one ventilating device (12) configured to generate an air flow destined for the housing compartment (5) of the supporting frame (3) and passing through at least one of said first and second longitudinal openings (6, 7) and exiting the supporting frame (3) through the lateral through opening (8),

- at least one manifold (9) arranged within the housing compartment (5) of the supporting frame (3), said manifold comprising a manifold lateral wall (10) engaged with said supporting frame (3) and extending substantially along the prevalent direction (D) of the supporting frame (3) between a first and a second end edges (11a, 12a), the first and the second end edges (11a, 12a) defining, at least partially, respective first and second axial openings (17, 18) configured to receive the air flow from the ventilating device (12) along a direction substantially parallel to the prevalent direction (D) of extension of the supporting frame (3), an internal passage volume (22) being at least partially laterally delimited by the manifold lateral wall (10) and by the first and second axial openings (13, 14),

the manifold lateral wall (10) further comprising a lateral through opening (15) fluidly connecting said internal passage volume (22) of the manifold (9) with the lateral through opening (8) of the supporting frame (3),

wherein the air flow is configured to pass through at least one of said first and second longitudinal openings (6, 7), enter into the internal passage volume (22) through at least one of the first and the second axial openings (17, 18) of the manifold lateral wall (10), and exit from the housing compartment (5) through the lateral through opening (15) of the manifold lateral wall (10) and the lateral through opening (8) of the supporting frame (3) along a direction (S) of ejection,

- a soundproofing element (40) arranged in at least one soundproof volume (41) within the housing compartment (5), the soundproof volume (41) being interposed between the manifold lateral wall (10) of the manifold (9) and the lateral wall (4) of the supporting frame (3).

2. The element according to the preceding claim, wherein the soundproofing element (40) comprises at least one between rock wool, cork, wood fiber, hemp, jute, rubber, foam in particular polyurethane or polyethylene foam, cotton or cotton fibres, in particular wherein the soundproofing element (40) is made by a fibrous or a foam based material, and/or wherein the soundproofing element (40) has a density comprised between 30 and 150 kg/m³.
3. The element according to any one of the preceding claims, wherein the manifold lateral wall (10) defines, entirely by itself or in combination with a portion of the lateral wall (4) of the supporting frame (3), a closed-loop lateral surface entirely delimiting laterally the internal passage volume (22), wherein:
- gas passage, through the manifold lateral wall (10), between the internal passage volume (22) and the soundproof volume (41) is prevented or hindered; or
 - the manifold lateral wall (10) comprises through holes (20) which allows the internal passage volume (22) to be in fluid communication with the soundproof volume (41), in particular wherein a maximum size of said through holes (20) is "n"-times lower than a respective size of the first and/or the second axial openings (17, 18), wherein the "n" term is comprised between 3 and 1000, more in particular between 10 and 500.
4. The element according to any one of the preceding claims, wherein the soundproof volume (41) is entirely filled by the soundproofing element (40), the soundproofing element (40) extending entirely from the first end edge (11a) to the second end edge (12a) of the manifold lateral wall (10), and wherein the soundproofing element (40) contacts an inner surface of the lateral wall (4) of the supporting frame (3) and an outer surface of the manifold wall (10).
5. The element according to any one of the preceding claims, wherein the housing compartment (5) comprises at least a first and a second soundproof volumes (41a, 41b) housed within the housing compartment (5) of the supporting frame (3), the internal passage volume (22) being interposed between the first and the second soundproof volumes (41a, 41b) with respect to a direction orthogonal to the prevalent direction (D) of the supporting frame (3), and wherein the first and the second soundproof volumes (41a, 41b) are substantially equal each other in volume and shape.
6. The element according to any one of the preceding claims, wherein the soundproofing element (40) entirely laterally surrounds the manifold lateral wall (10) except for the through opening (15) of the manifold (9), in particular wherein the soundproofing element (40) entirely laterally surrounds the internal passage volume (22) of the manifold (9) except for the through opening (15), the soundproofing element (40) being interposed between the manifold lateral wall (10) of the manifold (9) and the lateral wall (4) of the supporting frame (3), in particular the soundproofing element (40) being entirely interposed between the internal passage volume (22) of the manifold (9) and the lateral wall (4) of the supporting frame (3).
7. The element according to any one of the preceding claims, wherein the manifold lateral wall (10) comprises a first and a second manifold lateral walls (10a, 10b) having at least a portion converging each other between a first section of minimum distance (Dmin) and a second section of maximum distance (Dmax), the second section of the manifold lateral wall (10) being opposite to the lateral through opening (8) of the supporting frame (3) with respect to the prevalent direction (D) of the supporting frame (3), the lateral through opening (15) of the manifold wall (10) coinciding with the first section of minimum distance (Dmin), and wherein the first and second manifold walls (10a, 10b) define in between, at least at the converging portion, an angle comprised between 20° and 120°, in particular between 30° and 90°, more in particular between 40° and 70°, optionally wherein a ratio between the maximum distance (Dmax) and the minimum distance (Dmin) respectively of the second and first section of manifold walls (10) is greater than 2, in particular it is comprised between 3 and 10, optionally the first and the second manifold lateral walls (10a) defining respective plane walls converging each other between the first section of minimum distance (Dmin) and the second section of maximum distance (Dmax).
8. The element according to the preceding claim, wherein the manifold lateral wall (10) further comprises a third manifold lateral wall (10c) arranged within the housing compartment (5) and extending along the prevalent direction (D), the third manifold lateral wall (10c) being interposed between, and connecting, the first manifold lateral wall (10a) and the second manifold lateral wall (10b), the internal passage volume being laterally delimited by the first, second and third lateral walls (10a, 10b, 10c),

and wherein the third manifold lateral wall (10c) is arranged opposite to the through opening (15) of the manifold (9) with respect to a frame axis (FA) of the supporting frame (3),
 the third manifold lateral wall (10c) being arranged closer to an inner surface of the lateral wall (4) of the supporting frame (3) than to the through opening (15),
 wherein the housing compartment (5) comprises a third soundproof volume (41c) containing the soundproofing element (40), the third soundproof volume (41c) being delimited by the third manifold lateral wall (10c) and by a portion of the lateral wall (4) of the supporting frame (3), the internal passage volume (22) being separated from the third soundproof volume (41c) by said third manifold lateral wall (10c),
 in particular the third soundproof volume (41) being further delimited by a portion of the first and the second manifold lateral walls (10a, 10b),
 wherein:

- the first soundproof volume (41a) is separated from the third soundproof volume (41c) by a portion of the first manifold lateral wall (10a); and
- the second soundproof volume (41b) is separated from the third soundproof volume (41c) by a portion of the second manifold lateral wall (10b);

and wherein the third soundproof volume (41c) is directly interposed between the first and the second soundproof volumes (41a, 41b).

9. The element according to the preceding claim, wherein.

- the first manifold lateral wall (10a) extends along the prevalent direction (D) of the supporting frame (3) between a respective first end edge (11a) and a respective second end edge (12a); and
- the second manifold lateral wall (10b) extends along the prevalent direction (D) of the supporting frame (3) between a respective first end edge (11b) and a respective second end edge (12b);

wherein at least a portion of the first end edge (11a) of the first manifold lateral wall (10a) is convergent, in particular transversal, to a respective portion of the first end edge (11b) of the second manifold lateral wall (10b), optionally the first end edge (11a) of the first manifold lateral wall (10a) being entirely convergent, in particular transversal, to the first end edge (11b) of the second manifold lateral wall (10b),

and wherein at least a portion of the second end edge (12a) of the first manifold lateral wall (10a) is convergent, in particular transversal, to a respective portion of the second end edge (12b) of the second manifold lateral wall (10b), optionally the second end edge (12a) of the first manifold lateral wall (10a) being entirely convergent, in particular transversal, to the second end edge (12b) of the second manifold lateral wall (10b),
 and wherein:

- the first manifold lateral wall (10a) extends transversal, in particular orthogonal, to the prevalent direction (D) of the supporting frame (3) between a first outlet edge (13a) and a first inner edge (14a);
- the second manifold lateral wall (10b) extends transversal, in particular orthogonal, to the prevalent direction (D) of the supporting frame (3) between a second outlet edge (13b) and a second inner edge (14b);

wherein the first outlet edge (13a) and the second outlet edge (13b) are substantially parallel each other and distanced by said minimum distance (D_{min}),

and wherein the first inner edge (14a) and the second inner edge (14b) are substantially parallel each other and distanced by said maximum distance (D_{max}),

optionally wherein the first outlet edge (13a), the first inner edge (14a), the second outlet edge (13b) and the second inner edge (14b) are substantially parallel each other,

in particular the first and the second outlet edges (13a, 13b) being opposite to the first and the second inner edges (14a, 14b) with respect to the prevalent direction (D) of the supporting frame (3).

10. The element according to any one of the preceding claims, wherein the modular element (1) further comprises at least one cover cap (50) arranged within, in particular entirely within, the housing compartment (5),

said cover cap (50) extending transversal, optionally orthogonal, to the prevalent direction (D) of the supporting frame (3) between the first

and/or the second end edges (11, 12) of the manifold (9) and a portion of the lateral wall (4) of the supporting frame (3), said cover cap (50) covering the soundproof volume (41) and the soundproofing element (40),
and wherein:

- said cover cap (50) defines a closed surface configured to prevent, or limit an amount of, the air flow coming from the ventilating device (12) to enter the soundproof volume (41) through the cover cap (50); or
- the at least one cover cap (50) defines a surface having through holes (51) configured to allow at least partially the air flow from the ventilating device (12) to cross the cover cap (50) and enter the soundproof volume (41).

11. The element according to any one of the preceding claims, wherein the through opening (15) of the manifold wall (10) has a rectangular parallelepiped shape having:

- a length directed as the prevalent direction (D) of the supporting frame (3),
- a width orthogonal to said length and defining, in combination with said length, an outlet section configured to allow the air flow to exit the housing compartment (5),
- a depth extending internally to the housing compartment (5) starting from an external surface of the lateral wall (4) of the supporting frame (3), said depth being comprised between 3cm and 15cm and/or being set as a function of said length and/or of said width, in particular wherein said depth is higher than said width, more in particular wherein said depth is 10% to 300% higher than the width, in particular said depth being 50% to 100% higher than the width of the through opening (15).

12. An air curtain barrier (2) comprising:

- at least one modular element (1) according to any one of the preceding claims, optionally the operative position of the through opening (8) of said at least one modular element (1) being angularly adjustable about the development direction (D) of the supporting frame (3),
- at least one ventilating device (12) associated, in particular coupled, to said at least one modular element (1) and configured for generating and delivering the air flow to the housing compartment (5) of the supporting frame (3), wherein the ventilating device (12) comprises a motor frame (80) defining an internal volume (81), a motor (82), in particular an electric motor, ar-

ranged within the internal volume (81) of said motor frame (80), and at least one fan (83), in particular a centrifugal, radial or axial fan, coupled to said motor (82), said motor (82) being configured to rotate the fan (83) to generate the air flow towards said modular element, wherein the fan is configured to rotate about a rotation axis (RA) substantially orthogonal to the prevalent direction (D) of the modular elements (1) and to the ejection direction (S) of the modular element (1) configured to receive the air flow from said ventilating device (12), wherein the at least one modular element (1) is configured for receiving the air flow from the ventilating device (12) and channelling it outside the through opening (8) along the ejection direction (S).

13. Air curtain barrier (2) according to the preceding claim, wherein the at least one modular element (1) comprises at least a series of modular elements (1), the series of modular elements (1) being reciprocally engaged with each other and consecutively located along a prevalent axis of extension (1a) parallel to the prevalent direction (D) of extension of each modular element (1), the operative position of a through opening (8) of at least one modular element (1) being angularly adjustable about the development axis (1a) with respect to an operative position of at least one other lateral outlet opening (8) of a different modular element (1),

and wherein the at least one ventilating device (12) is configured for generating and delivering the air flow to the housing compartments (5) of said series of modular elements (1), the at least a series of modular elements (1) comprising:

- at least one vertical series of modular elements (1) arranged along a substantial vertical direction one over the other and along the prevalent direction (D) of each supporting frame (3), optionally said vertical series of modular elements (1) defining a substantially rectilinear structure along said vertical direction;
 - at least one optional horizontal series of modular elements (1) arranged along a substantial horizontal direction and along the prevalent direction (D) of each supporting frame (3), optionally said horizontal series of modular elements (1) defining a substantially rectilinear structure along said horizontal direction;
- wherein the vertical series of modular elements (1), and optionally the horizontal series of modular elements (1), lie on a com-

mon reference plane (RP), said reference plane (RP) simultaneously crossing the vertical direction of the vertical series, and optionally the horizontal direction of the horizontal series of modular elements (1),
or

- a first vertical series of modular elements (1) arranged along a substantial vertical direction one over the other and along the prevalent direction (D) of each supporting frame (3) of said first vertical series, optionally said vertical series of modular elements (1) defining a substantially rectilinear structure along said vertical direction; and

- a second vertical series of modular elements (1) arranged along a substantial vertical direction one over the other and along the prevalent direction (D) of each supporting frame (3) of said second vertical series, optionally said vertical series of modular elements (1) defining a substantially rectilinear structure along said vertical direction, optionally the first and the second vertical series of modular elements (1) being substantially parallel each other and separated by a distance W comprised between 1m and 8m, in particular between 2m and 4m,

- optionally at least one horizontal series of modular elements (1) arranged along a substantial horizontal direction and along the prevalent direction (D) of each supporting frame (3), optionally said horizontal series of modular elements (1) defining a substantially rectilinear structure along said horizontal direction,

wherein the first vertical series of modular elements (1) and the second vertical series of modular elements (1) lie on a common reference plane (RP), said reference plane (RP) simultaneously crossing the vertical direction of the first and second vertical series of modular elements (1), optionally wherein the horizontal series of modular elements (1) lie on a common reference plane (RP) with the first and the second vertical series of modular elements, said reference plane (RP) simultaneously crossing the vertical direction of the first and second vertical series and of the horizontal direction of the horizontal series of modular elements (1),

and wherein the ejection direction (S) of each modular element (1) is positioned at a predefined angular orientation with respect to said reference plane (RP), said angular orientation defining an angle α included between the reference plane (RP) and the ejection direction (S) comprised between 40° and 85° , in particular

between 60° and 80° , more in particular between 65° and 75° .

14. Air curtain barrier (2) according to any one of the preceding claims 12 and 13, wherein the ventilating device (12) comprises an intake aperture (87) configured to promote air to the fan (83), the air curtain barrier (2) further comprising a soundproof panel (70) arranged in front of said intake aperture (87) of the ventilating device (12) and spaced from said intake aperture (87) by a distance comprised between 10cm and 50cm and/or a distance defined as a function of a size of the intake aperture (87) or a fan (83) diameter.

15. Air curtain barrier (2) according to the preceding claim, wherein the air curtain barrier (2) comprises at least one support structure (90) configured to support the at least one modular element (1), in particular to support the vertical and/or the horizontal series of modular elements (1), the support structure being engaged to the at least one modular element (1) and configured to couple to a building façade (101),

the soundproof panel (70) being engaged and carried by said at least one support structure and extending along a main surface facing the intake aperture (87), said main surface of the soundproof panel (70) being substantially perpendicular to the reference plane (RP) and/or angularly tilted with respect to a rotation axis of the fan (83) of the ventilating device (82) by an angle α comprised between 40° and 85° , in particular between 60° and 80° , more in particular between 65° and 75° , optionally wherein the main surface of the soundproof panel (70) is angularly tilted with respect to the ejection direction (S) of the at least one modular element (1) by an angle β complementary to the angle α , said angle β being in particular comprised between 5° and 35° , in particular between 10° and 30° , more in particular between 15° and 25° .

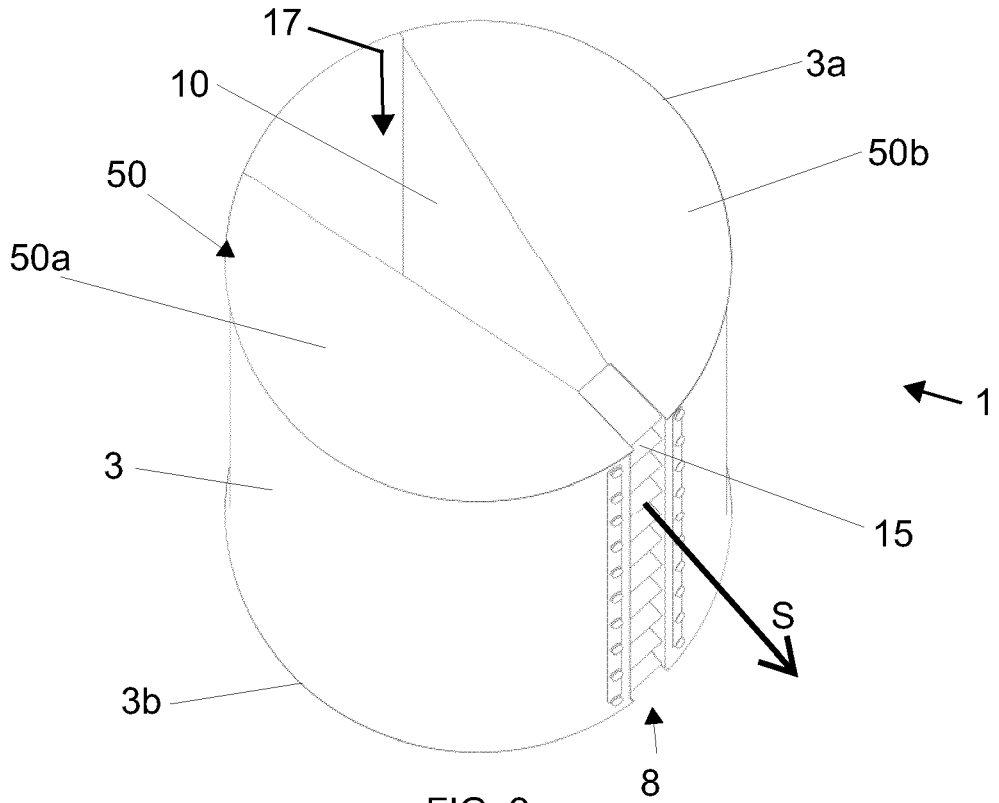

FIG. 2

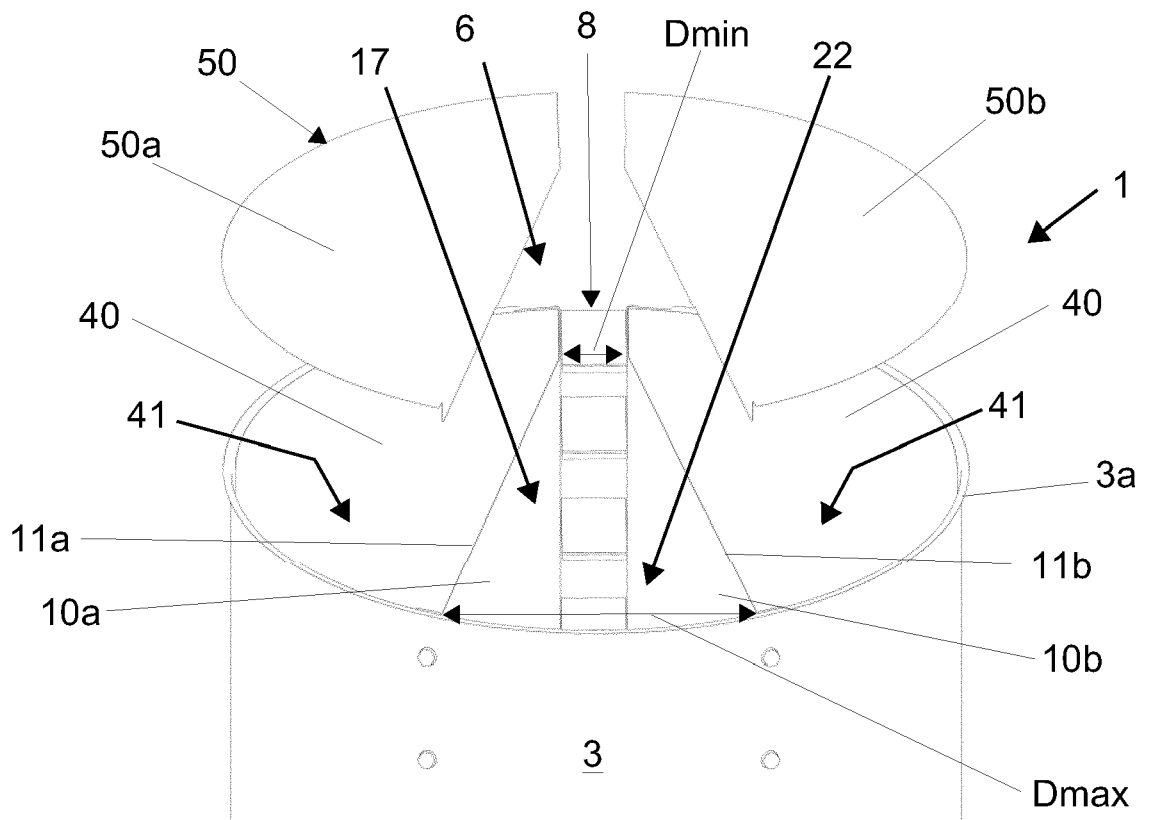

FIG. 3

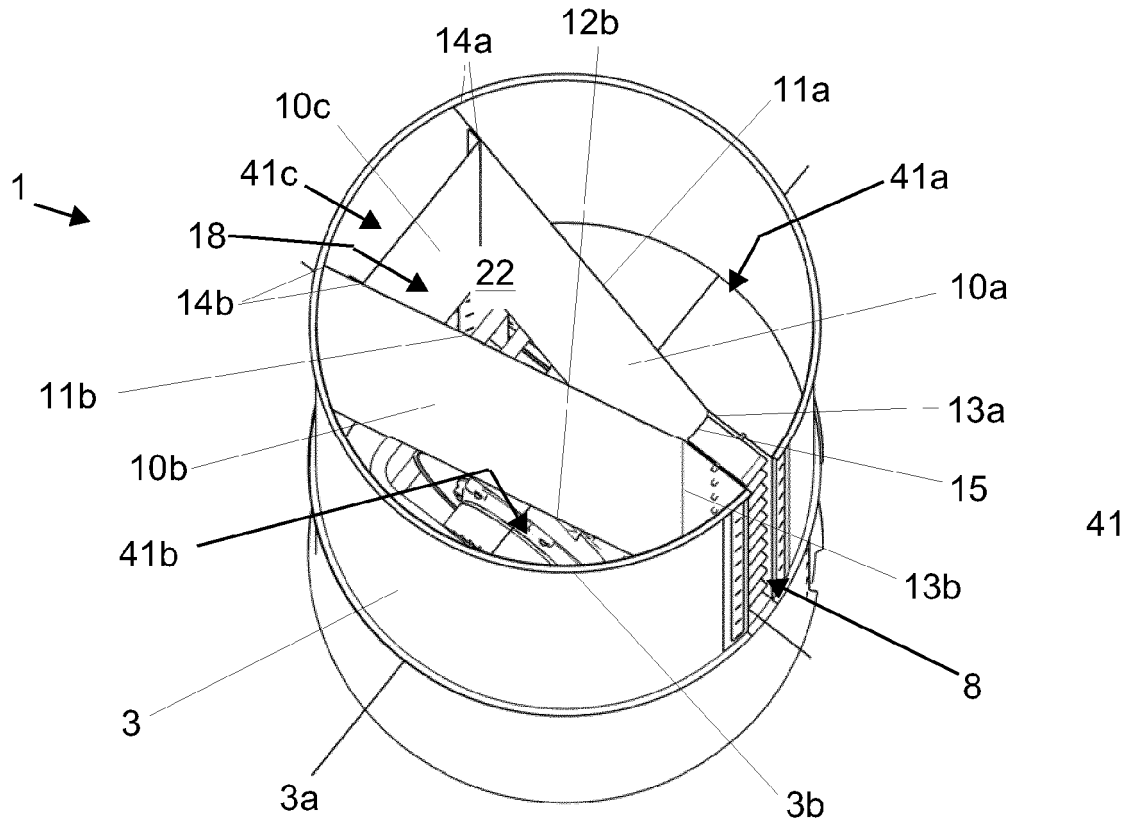

FIG. 4

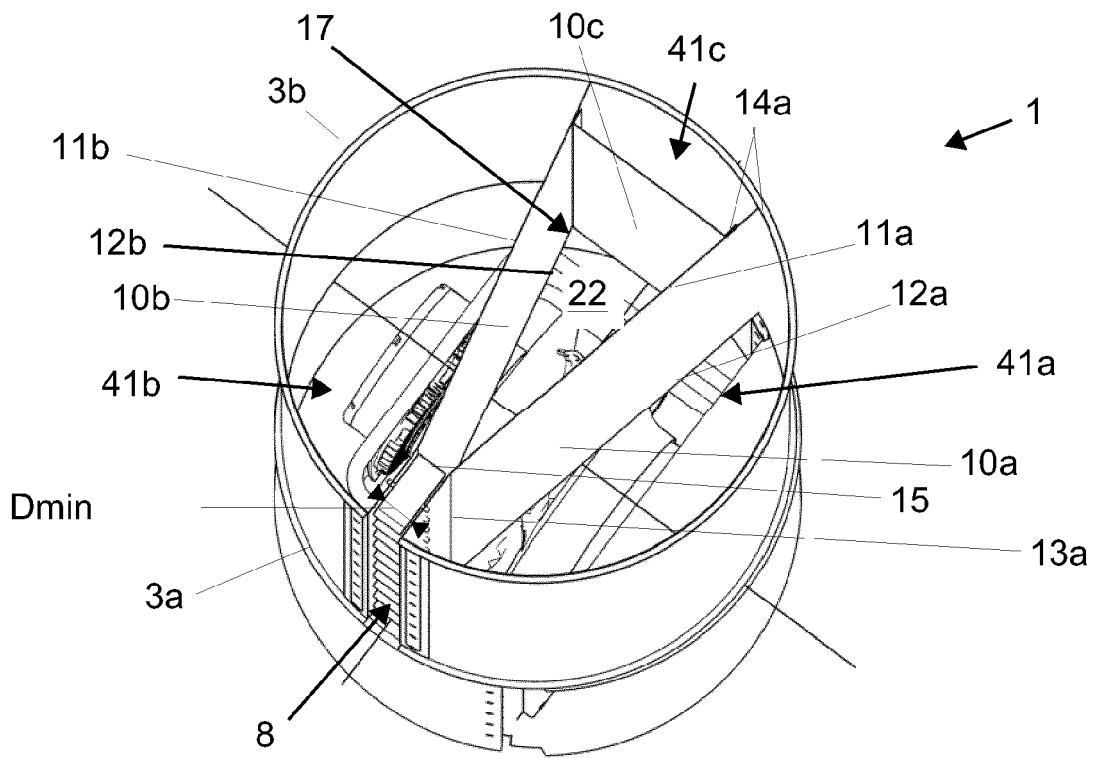

FIG. 5

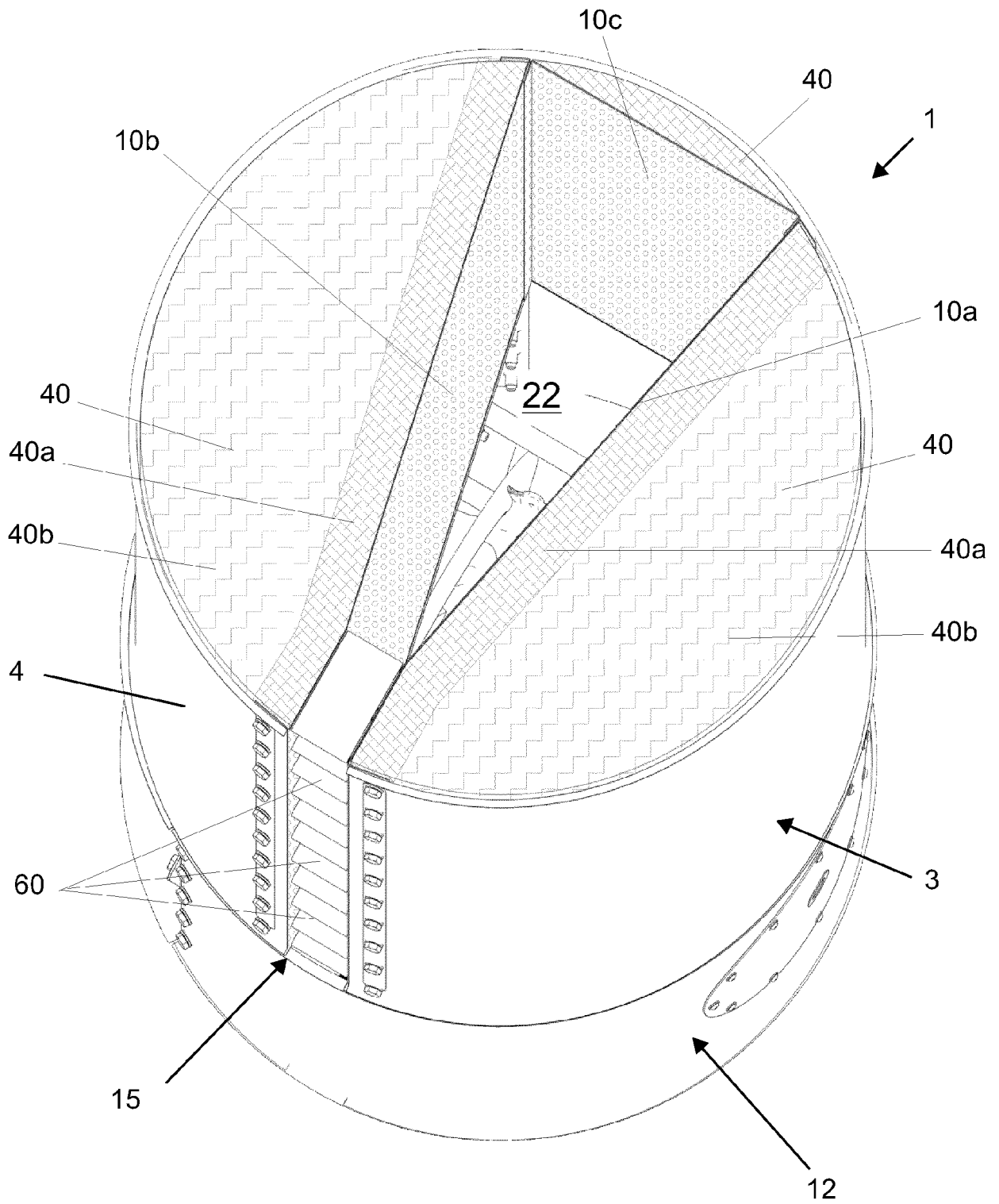

FIG. 5B

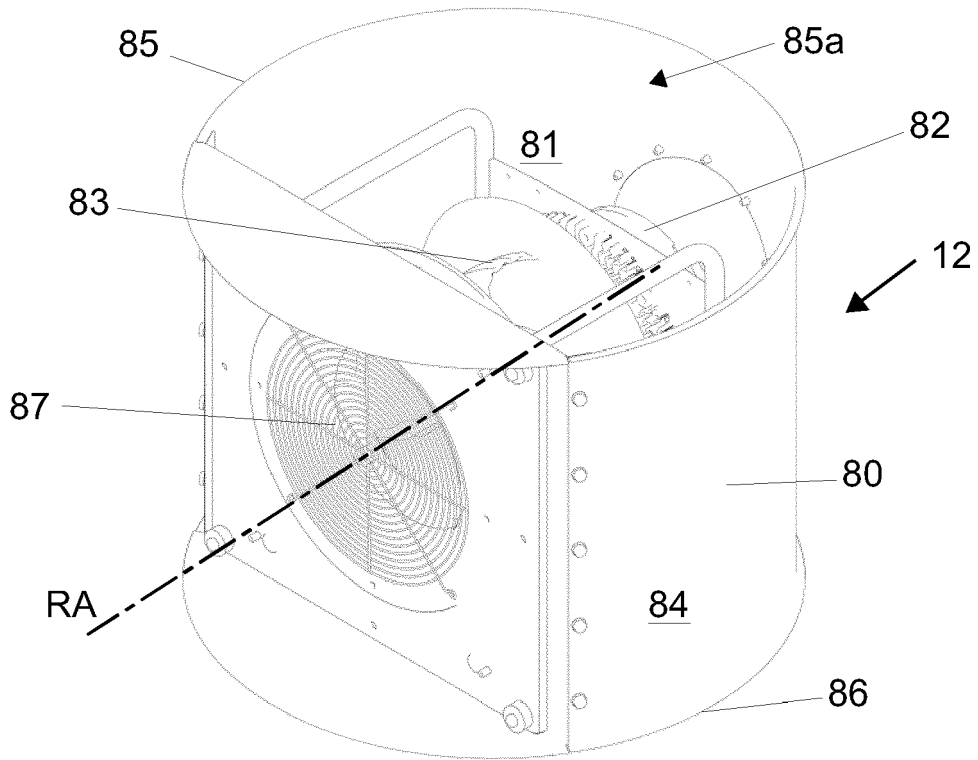

FIG. 6

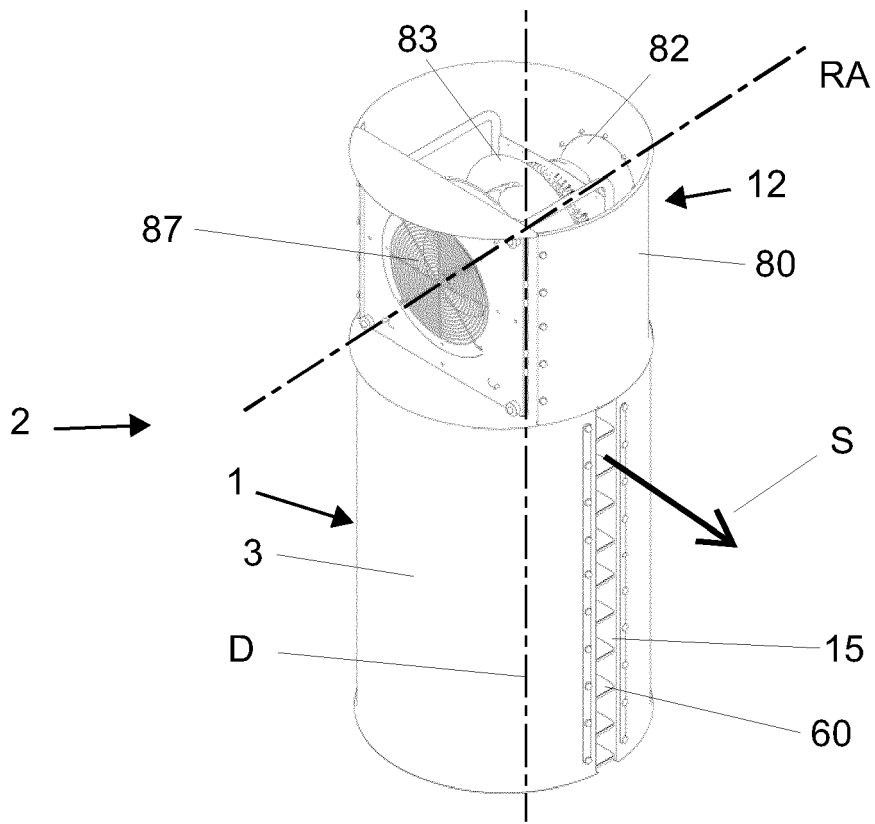

FIG. 7

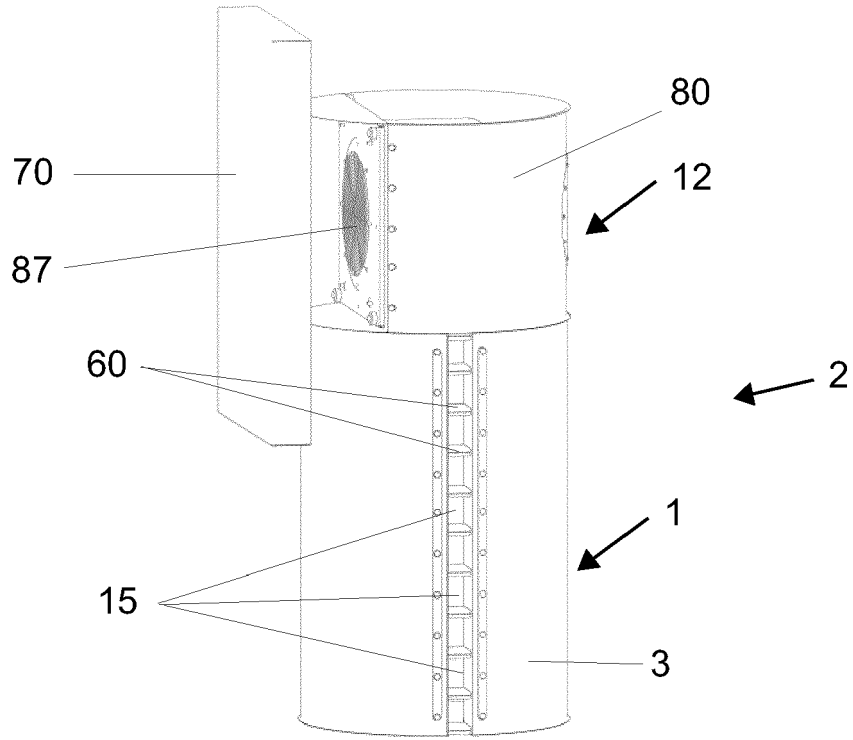

FIG. 8

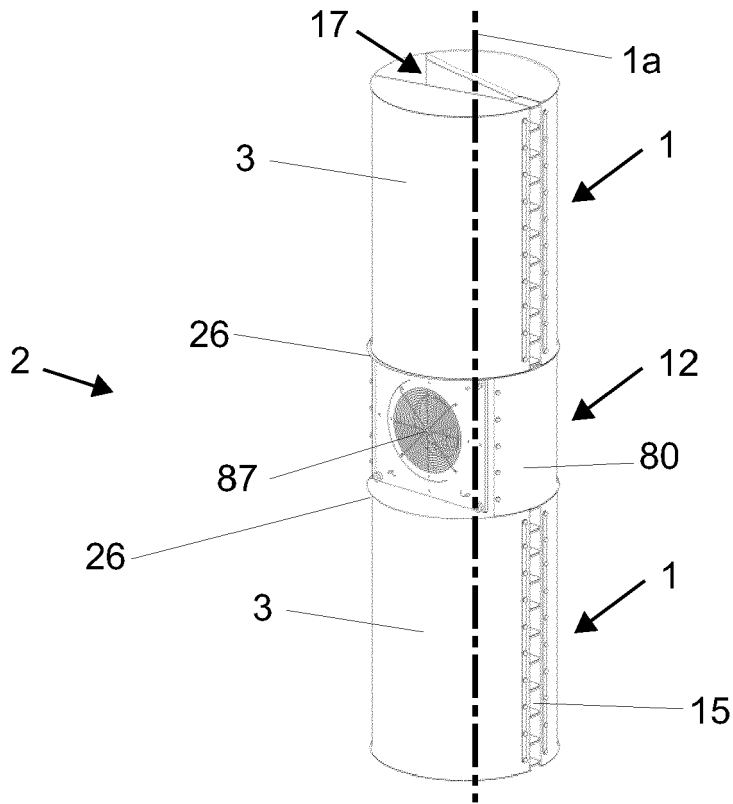

FIG. 9

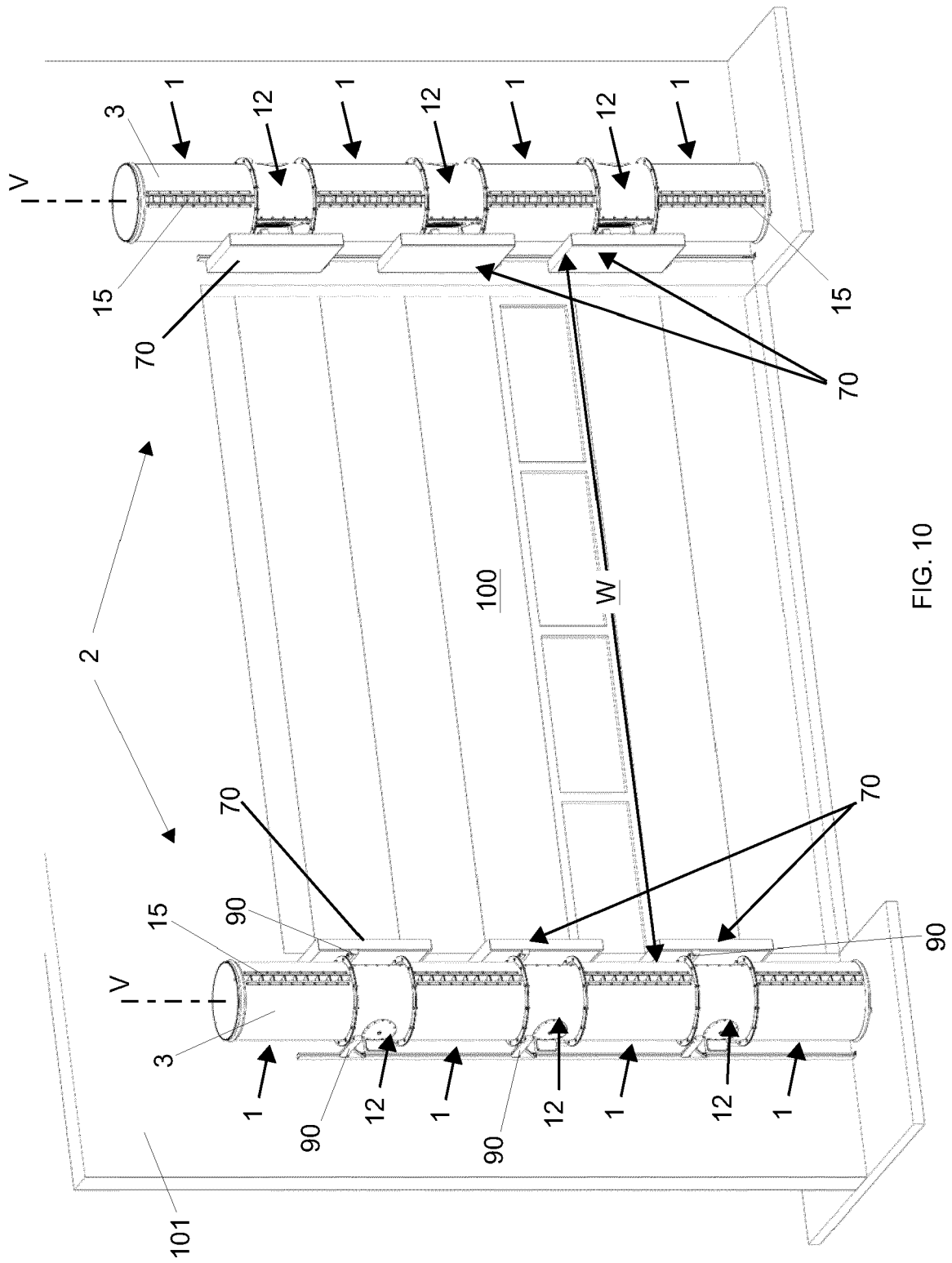

FIG. 10

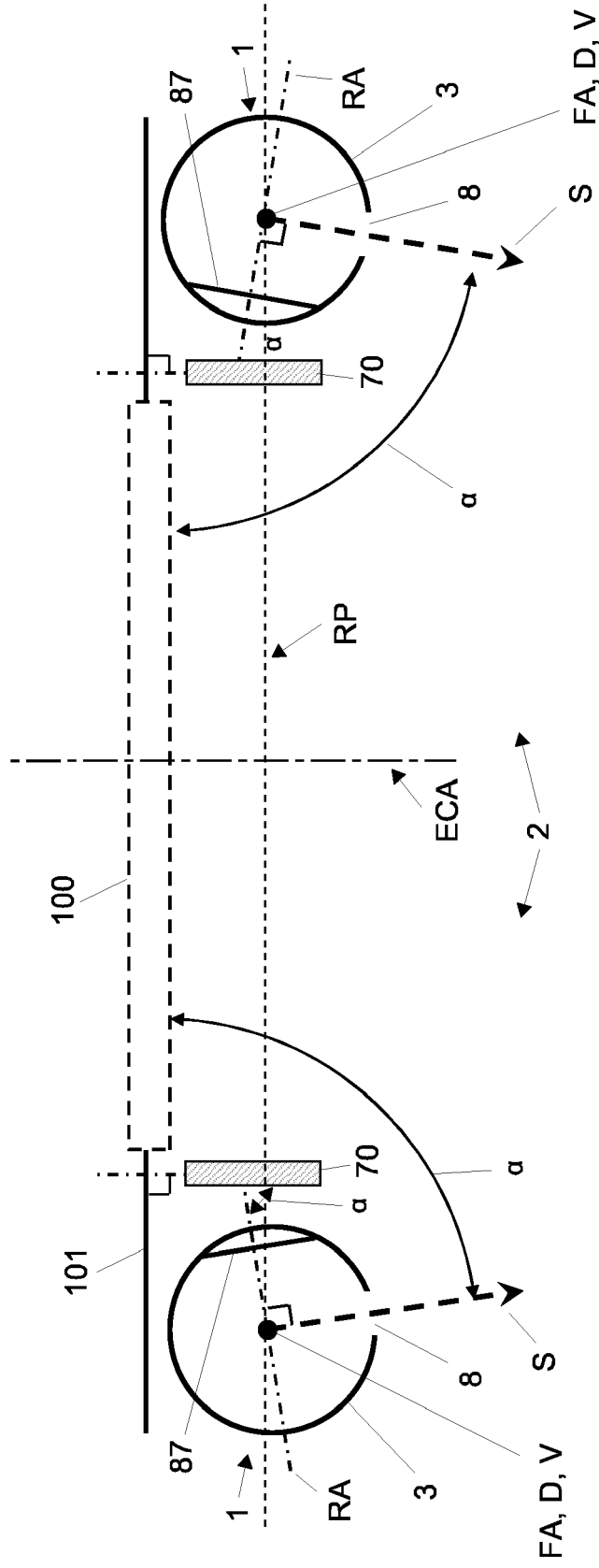

FIG. 11

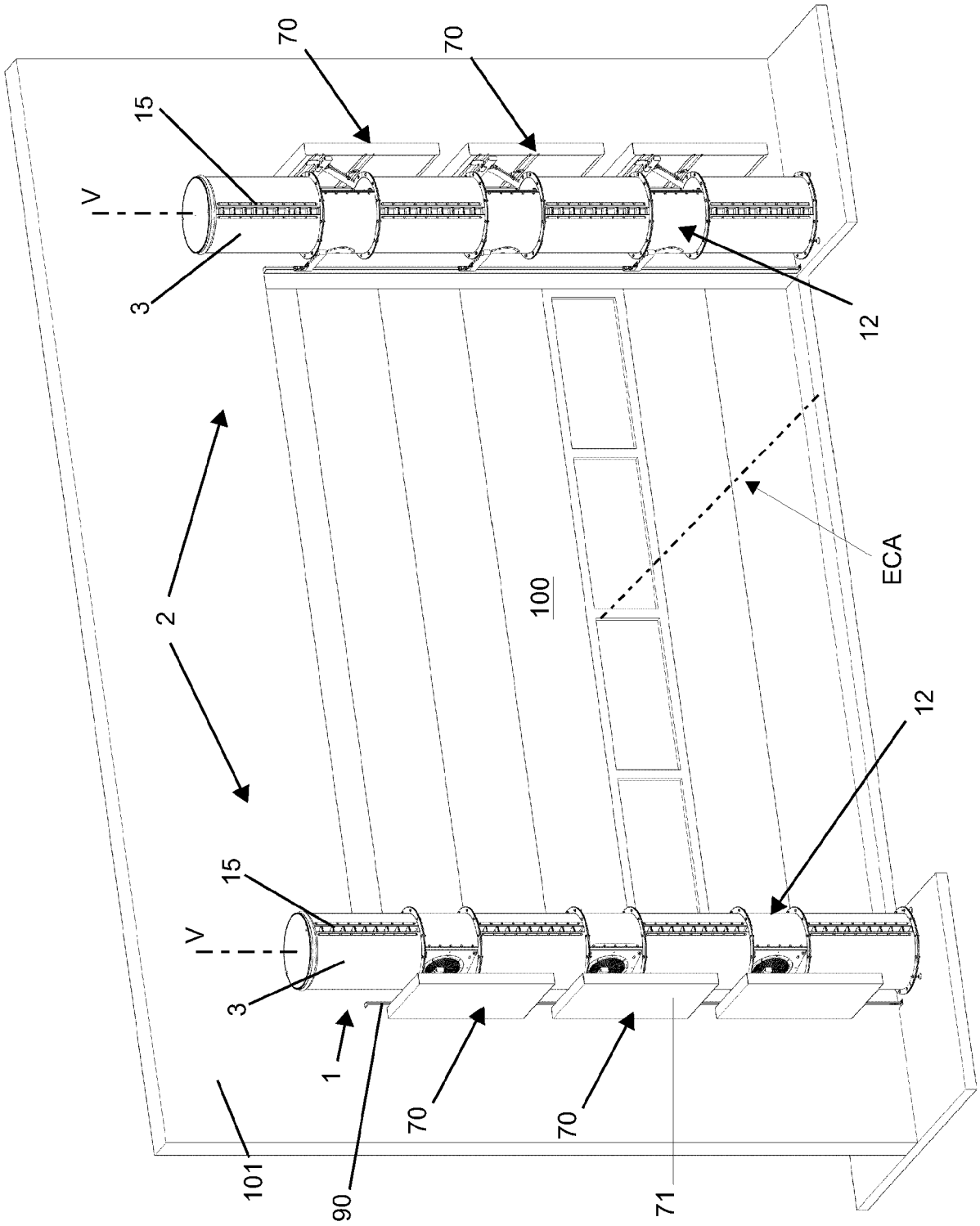

FIG. 12

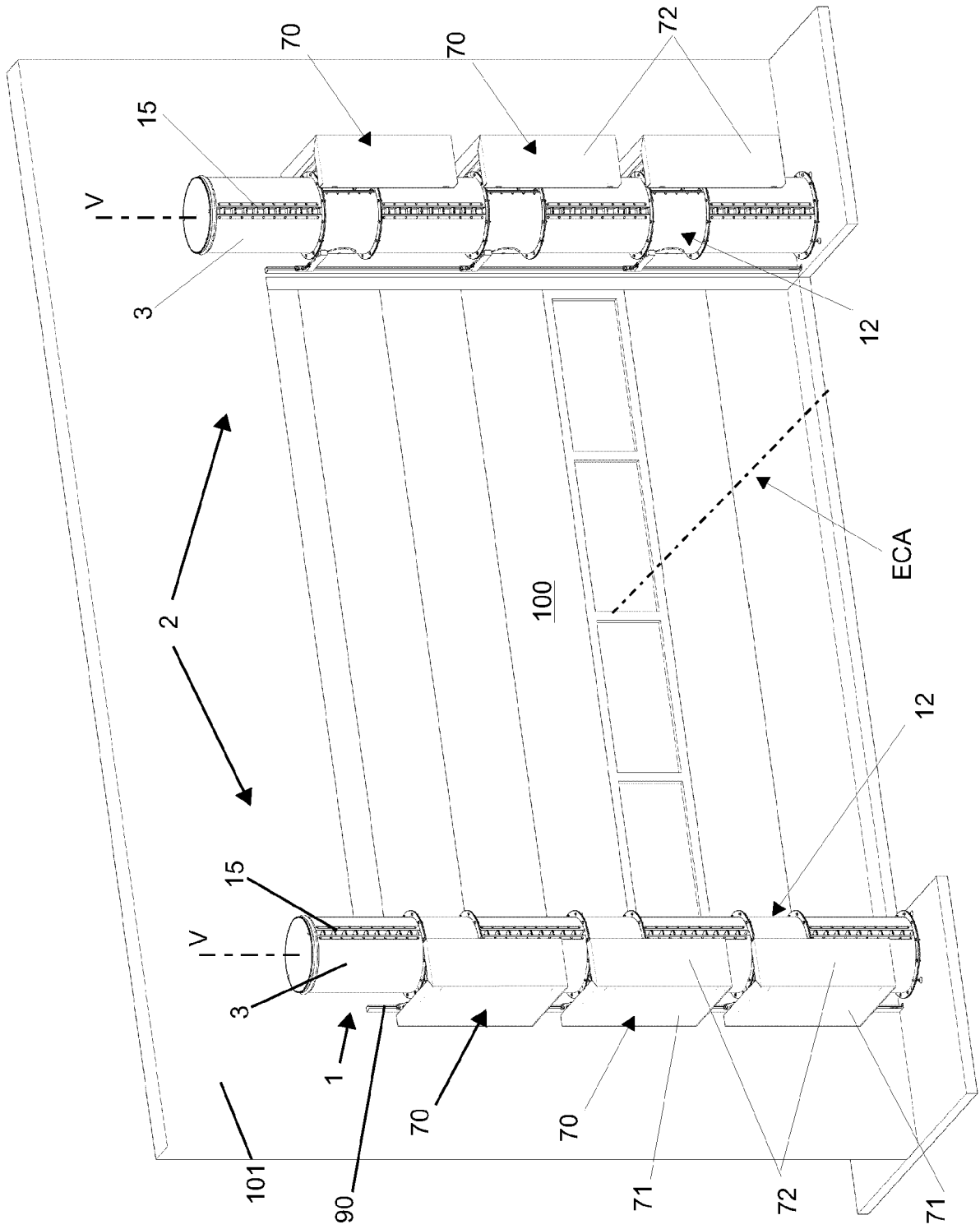

FIG. 13



EUROPEAN SEARCH REPORT

Application Number

EP 22 17 1691

5

10

15

20

25

30

35

40

45

50

55

DOCUMENTS CONSIDERED TO BE RELEVANT			
Category	Citation of document with indication, where appropriate, of relevant passages	Relevant to claim	CLASSIFICATION OF THE APPLICATION (IPC)
Y, D A	EP 2 995 876 A2 (ZAMBOLIN MARCO [IT]) 16 March 2016 (2016-03-16) * page 10, paragraph 10 - page 16, paragraph 45; figures 1-7, 7-9, 14-15, 19-20 *	1-7, 11-13 8-10, 14, 15	INV. F24F9/00
Y	EP 0 155 924 A2 (BAHCO VENTILATION AB [SE]) 25 September 1985 (1985-09-25) * page 1, line 19 - page 4, line 36; claim 1; figures 1, 3 *	1-7, 11-13	
A	DE 39 40 277 C1 (TEDDINGTON CONTROLS GMBH) 21 March 1991 (1991-03-21) * the whole document *	1	
			TECHNICAL FIELDS SEARCHED (IPC)
			F24F
The present search report has been drawn up for all claims			
Place of search Munich		Date of completion of the search 21 September 2022	Examiner Hoffmann, Stéphanie
CATEGORY OF CITED DOCUMENTS X : particularly relevant if taken alone Y : particularly relevant if combined with another document of the same category A : technological background O : non-written disclosure P : intermediate document		T : theory or principle underlying the invention E : earlier patent document, but published on, or after the filing date D : document cited in the application L : document cited for other reasons & : member of the same patent family, corresponding document	

1
EPO FORM 1503 03:82 (P04C01)

**ANNEX TO THE EUROPEAN SEARCH REPORT
ON EUROPEAN PATENT APPLICATION NO.**

EP 22 17 1691

5 This annex lists the patent family members relating to the patent documents cited in the above-mentioned European search report.
The members are as contained in the European Patent Office EDP file on
The European Patent Office is in no way liable for these particulars which are merely given for the purpose of information.

21-09-2022

Patent document cited in search report	Publication date	Patent family member(s)	Publication date
EP 2995876	A2	16-03-2016	NONE
EP 0155924	A2	25-09-1985	EP 0155924 A2 SE 444975 B
DE 3940277	C1	21-03-1991	NONE

EPO FORM P0459

For more details about this annex : see Official Journal of the European Patent Office, No. 12/82

REFERENCES CITED IN THE DESCRIPTION

This list of references cited by the applicant is for the reader's convenience only. It does not form part of the European patent document. Even though great care has been taken in compiling the references, errors or omissions cannot be excluded and the EPO disclaims all liability in this regard.

Patent documents cited in the description

- EP 2995876 A [0004]
- EP 155924 A [0005]