

S. J. SHIMER.
CUTTER HEAD.

No. 463,555.

Patented Nov. 17, 1891.

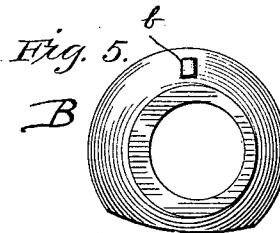
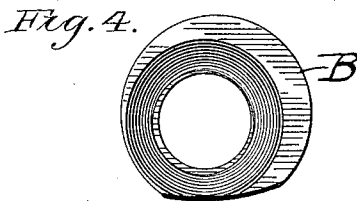
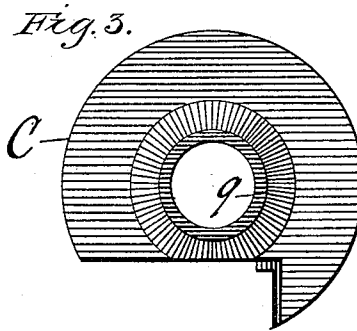
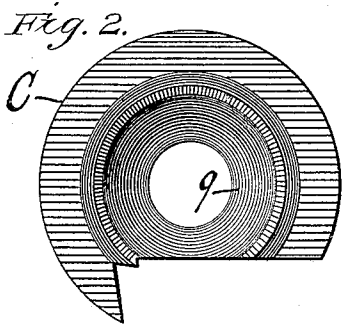
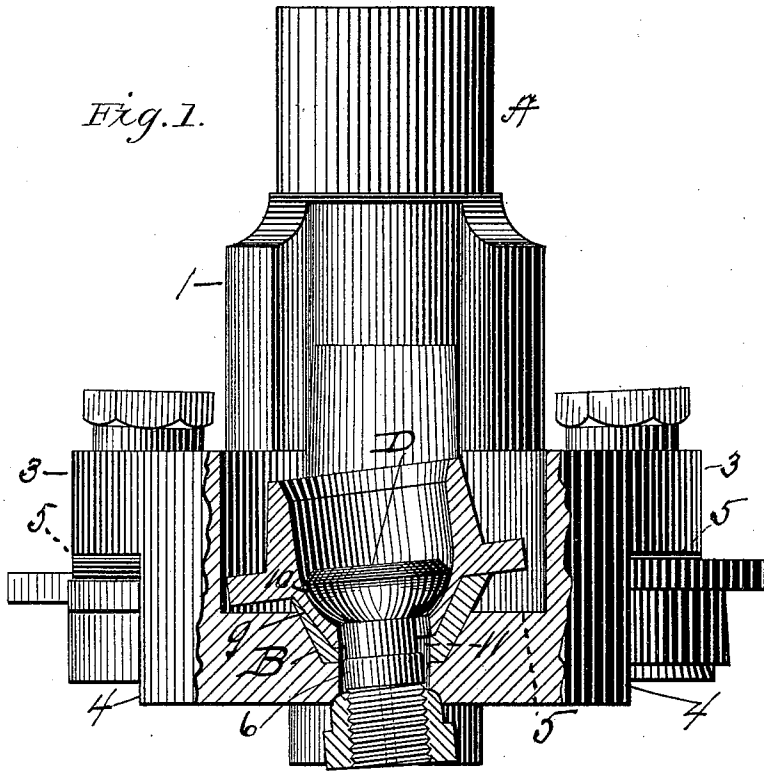

WITNESSES

Wm. Messier.
Wm H. Bates

INVENTOR,
Samuel J. Shimer.
By *A. G. Huffman,*
Attorney.

(No Model.)

2 Sheets—Sheet 2.

S. J. SHIMER.
CUTTER HEAD.

No. 463,555.

Patented Nov. 17, 1891.

E = H - 5 -

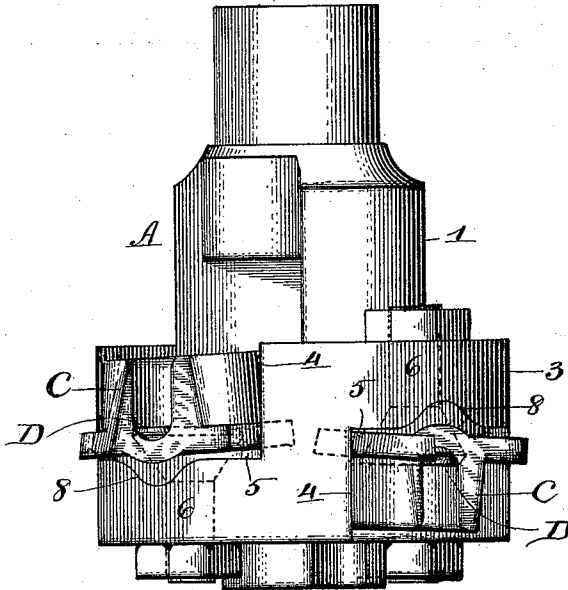

E = H - 7 -

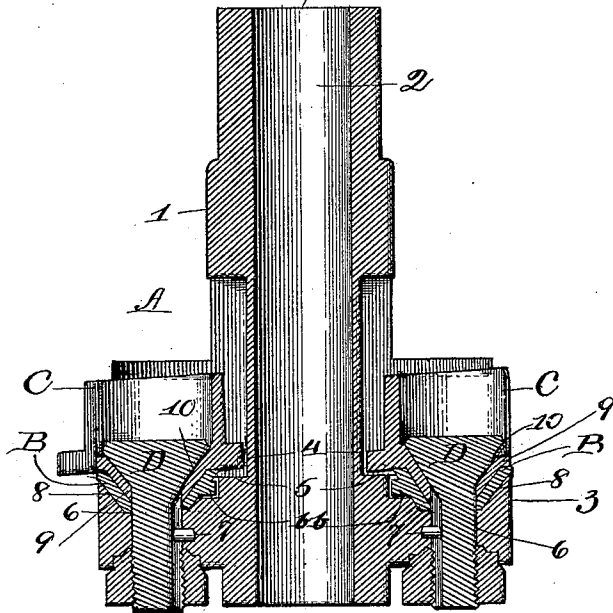

WITNESSES:

Albert B. Blackwood
F. M. Cressy,

INVENTOR

Saul J. Shimer

BY

A. G. Kuyler
ATTORNEY.

UNITED STATES PATENT OFFICE.

SAMUEL J. SHIMER, OF MILTON, PENNSYLVANIA.

CUTTER-HEAD.

SPECIFICATION forming part of Letters Patent No. 463,555, dated November 17, 1891.

Application filed September 8, 1890. Serial No. 364,245. (No model.)

To all whom it may concern:

Be it known that I, SAMUEL J. SHIMER, a citizen of the United States of America, residing at Milton, in the county of Northumberland and State of Pennsylvania, have invented a new and useful Cutter-Head, of which the following is a specification.

My invention has relation to improvements in cutter-heads for wood-working machines of that class wherein the cutter-head is secured to a vertical rotatable spindle or arbor and provided with bit-seats in the body-flange of the cutter-head to hold the cutting-bits.

The object of my invention is to provide improved means by which the bits may be inclined in different directions to the plane of rotation, and also by which the bits may be arranged in either direction of rotation.

My invention consists in the novel construction of parts and their combination, as hereinafter described, and particularly pointed out in the claims.

I have fully and clearly illustrated my improvements in the accompanying drawings, wherein—

Figure 1 is a side elevation of a cutter-head, one of the bit-seats, bit, clamping-bolt, and interposed inclined washer being shown in section. Fig. 2 is a top plan view of the bit. Fig. 3 is a bottom plan view of the bit. Fig. 4 is a perspective of the inclined washer. Fig. 5 is a central section of the same. Fig. 6 is a side elevation of a cutter-head equipped with my improvements. Fig. 7 is a vertical section through the cutter-head, showing the parts assembled.

A designates the cutter-head, formed with a hub 1, having the usual spindle-bore 2 and formed with the usual substantial annular flange 3, in which are formed bit-seats 4, arranged in pairs oppositely disposed in the upper and lower faces of the flange 3, the under bit-seats being at right angles to the upper ones. The bottoms or floors 5 of the bit-seats are made level or on a plane parallel with the direction of rotation and not inclined, as in some instances. In the middle of each bit-seat is a bolt-hole 6 to receive the clamping-bolts which hold the cutting-bits in the seats, and in the bolt-holes are projecting lugs 7 to engage in grooves in the clamping-bolts and keep them from turning when tightened up or loosened.

The foregoing description is general and applicable to cutter-heads of the kind and forms no part of my present invention, except as the body of the cutter-head enters as an element into the legal combination of the parts claimed in operative aggroupment.

In that part of the bit-seat surrounding each bolt-hole is formed a conical depression 8, in which is fitted a conically-shaped washer B, having in its upper surface a conically-shaped depression, the surfaces of the washer being arranged obliquely to each other, so that the upper surface will be in an inclined direction with the other, so as to present an inclined seat when the washer is in position in the seat of the cutter-head, substantially as shown in the drawings. In the washer is a bolt-hole, as shown, through which the clamping-bolt passes, and the washer is formed with a lug *b* to enter a corresponding hole in the washer-seat to prevent the turning of the washer.

C designates the cutting-bit, formed with a conical bottom portion 9, surrounding the bolt-hole, and having a conical depression 10 in its upper face to receive the rounded under face of the clamping-bolt, as shown. The bolt-hole of the bit is made larger than the neck or stem of the clamping-bolt, as seen at 11, in order that when a reverse bit is seated in the washer it will have room in the hole to accommodate itself to the reversed incline of the washer or to seat itself in the depression of the washer, irrespective of the position of the bit. The cutting flange or rim of the bit may be of any of the conformations or contours required to give the requisite shape to the cut. The interposition of these inclined or tapering conical washers having the required incline to give the desired clearance to the bits, in a cutter-head having level bit-seats, adapts the head to do either tongue or groove work, according to the direction of the incline, and by changing the bits and washers the heads can be equipped to run in either direction, as hereinafter stated.

The clamping-bolts D have a head to fit the conical depression of the bit and a groove to receive the lug in the bolt-holes of the head.

The cutter-head with bit-seats having conical depressions and the bits with conical projections on their bottoms are not claimed in this

application, as they form the subject-matter of an independent application for Letters Patent, being Serial No. 359,202, filed June 19, 1890.

5 To adapt the head to reverse cuts, take off the upper bits and washers and also the under bits and washers, and then arrange and secure the washers and bits taken from the upper seats in the seats below and those from
10 below in the seats above, and the clearance will come right.

Having thus described my invention, what I claim is—

1. The combination of the cutter-head
15 formed with bit-seats having a conical depression formed around the bit-clamping bolt-holes, a concavo-convex washer in the bit-seats having an inclined upper surface, a circular bit in the washer, and a clamping-bolt
20 projected through the bit-washer and head-flange, substantially as and for the purpose specified.

2. In combination, the cutter-head formed with bit-seats having their floor parallel with the plane of rotation and formed with a conical depression surrounding the bolt-hole in the seat, a washer having its surfaces oblique to each other and a concavo-convex middle portion surrounding the bolt-hole, a cutting-bit having a conical-shaped bottom to set in
25 the depression of the washer and a bolt-hole of larger diameter than the neck of the clamping-bolt, and a clamping-bolt projected through the bit, washer, and head-flange, whereby the incline of the cutter may be re-
30 versed and the tool adapted to run with bits to cut in either direction, as specified.

In witness whereof I have hereunto set my hand in the presence of two attesting witnesses.

SAMUEL J. SHIMER.

Attest:

ELMER S. SHIMER,
JOHN A. BECK.