

May 9, 1933.

C. E. LUCKE

1,908,374

OIL STILL

Filed March 28, 1928

2 Sheets-Sheet 1

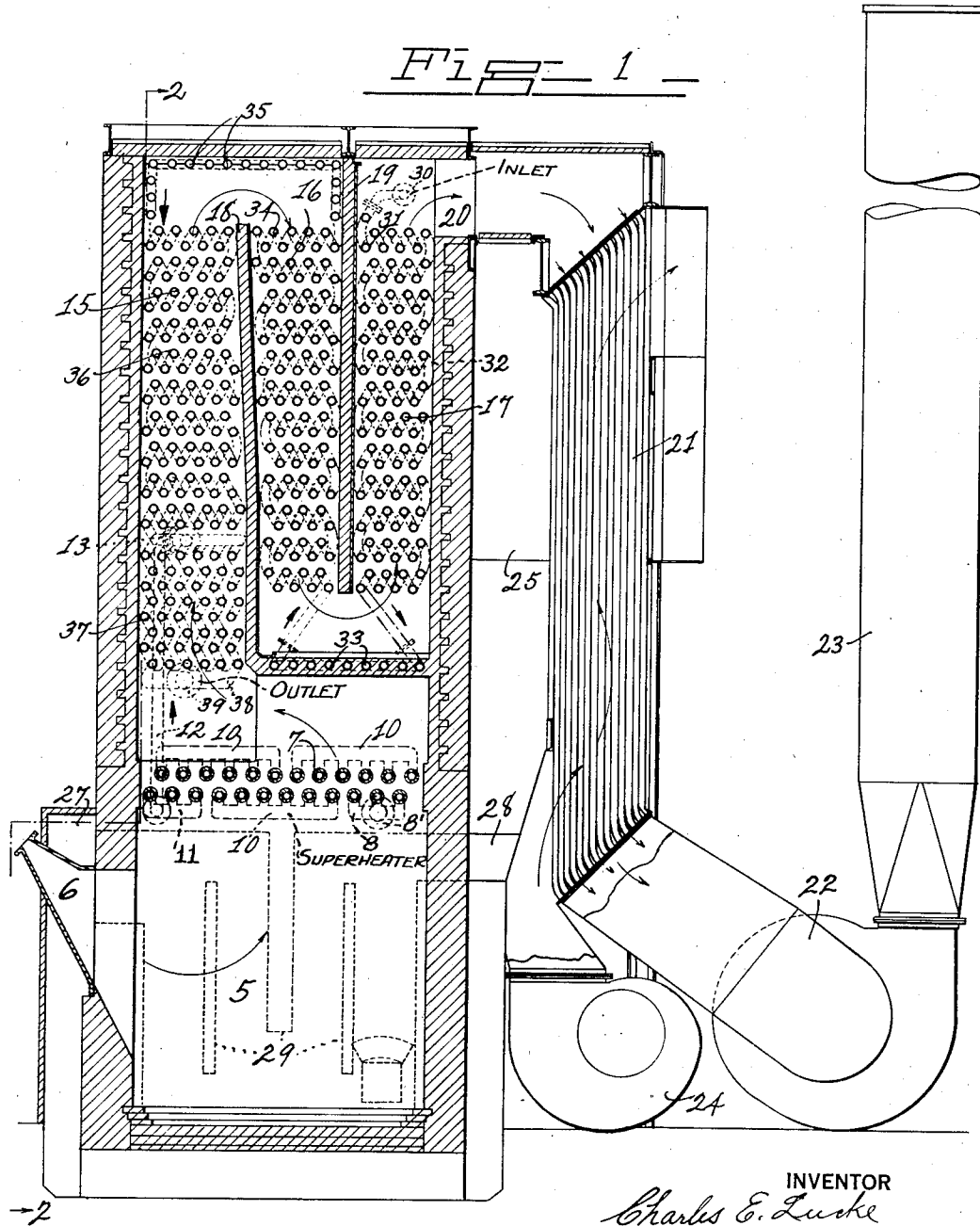

INVENTOR  
*Charles E. Lucke*  
BY  
*Richard S. Scull*  
ATTORNEYS

May 9, 1933.

C. E. LUCKE

1,908,374

OIL STILL

Filed March 28, 1928

2 Sheets-Sheet 2

Fig 2-1

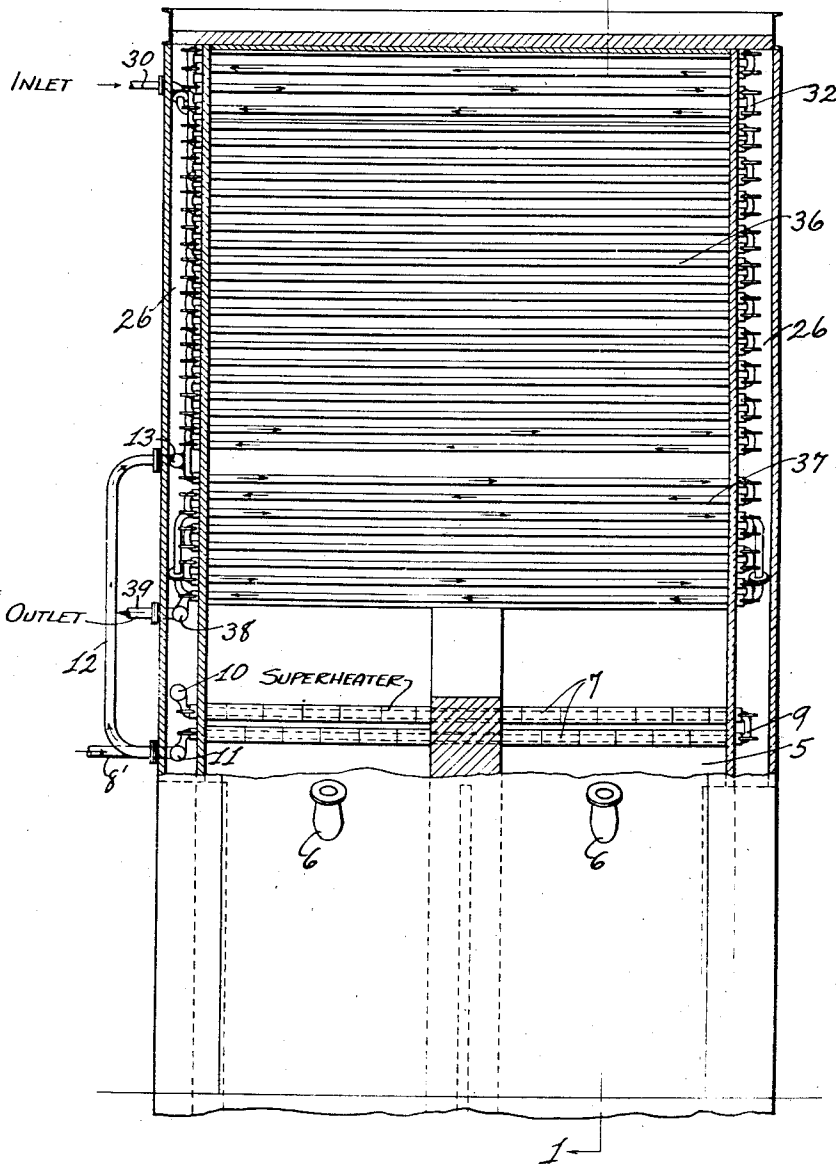

INVENTOR  
*Charles E. Lucke*  
BY  
*Difford & Scull*  
ATTORNEYS

## UNITED STATES PATENT OFFICE

CHARLES E. LUCKE, OF NEW YORK, N. Y., ASSIGNOR TO THE BABCOCK & WILCOX COMPANY, OF BAYONNE, NEW JERSEY, A CORPORATION OF NEW JERSEY

## OIL STILL

Application filed March 28, 1928. Serial No. 265,245.

This invention relates to an oil still in which oil is passed through tubes in series that are located above a furnace and are shielded from the radiant heat of the furnace by means of tubes with refractory jackets. The hot products of combustion from the furnace pass through the radiant heat shield and contact with the oil tubes before they become materially cooled.

The invention will be understood from the description in connection with the accompanying drawings in which Fig. 1 is a vertical section through an illustrative embodiment of the invention taken along the line 1—1 of Fig. 2, and Fig. 2 is a section taken along the line 2—2 of Fig. 1.

In the drawings reference character 5 indicates a furnace chamber that is provided with fuel burners 6 for powdered coal or other combustible material. A horizontally disposed radiant heat screen 7 is located above the furnace chamber 5 and is made up of tubes that are covered with tile and spaced apart so as to permit gases or hot products of combustion from the furnace to pass between the tubes. A header 8 for a group of tubes for the screen is located on the outside of the furnace and an inlet pipe 8' leads to this header. In the illustrative embodiment of the invention, the screen comprises two rows of staggered parallel tubes and a group of three tubes in the lower row is connected in parallel to the header 8. The other ends of the tubes of this group are connected by return connectors 9 to a group of three tubes in the upper row and the ends of the tubes in the upper row are connected to a header 10 that is located outside of the furnace wall above the header 8 and is about twice as long as the header 8. Similar groups of tubes of three each connect this header 10 through end connectors and through other headers 10 so that the fluid entering the header 8 passes a plurality of times across the top of the combustion chamber, finally entering the header 11, and thence passing through the pipe 12 to a header 13. The tubes constituting the radiant heat screen are covered with jackets of refractory material.

There is no necessity of using a great excess

of air for cooling purposes and the number of tubes in the screen 7 can be restricted to the number that is necessary to provide the radiant heat screen.

The space above the screen 7 is divided into a plurality of conduits or gas passages 15, 16 and 17 that taper in the direction of the gas flow. The gas passages 15, 16 and 17 are made tapering by means of baffles 18 and 19 slightly inclined to the vertical, the baffle 18 terminating short of the upper end of the gas passages and its lower end being connected to the right hand wall of the passages as indicated in Fig. 1. The baffle 19 extends from the upper portion of the gas passages and its lower end terminates short of the lower portion of the baffle 18. A conduit leads from the exit 20 for the waste gases to an air heater 21 at the lower end of which a suction fan 22 is connected and the outlet from this fan leads to the stack 23. The fresh air fan 24 forces air through the air heater 21 into a conduit 25 that leads to the spaces 26 on the outside of the conduits 15, 16 and 17 from which the gases pass into the space 27 in front of the furnace chamber 5 and thence into the furnace for combustion purposes.

A branch conduit 28 may lead from the fan 24 into the spaces along the sides of the furnace 5, baffles 29 being provided therein to cause the air to pass in a zigzag direction through the spaces to the space 27 from which it enters the furnace.

An oil inlet pipe 30 leads to the upper portion of the gas conduit 17 and is connected to the end of the straight oil tube 31, the end of which is in turn connected by a return connection 32 to the end of the next oil tube 31 and so on through the gas passage 17 with the oil passing through the tubes that extend across this passage. These tubes 31 are made straight so that they can be readily cleaned and extend through the gas passage. The oil passes through the lower one of the tubes 31 into a row of tubes 33 located in the lower portion of the baffle 18, thence upwardly through a series of tubes 34, similar to the tubes 32 and similarly connected but located in the gas passage 16,

thence through the row of tubes 35 above the passage 16, thence through the tubes 36 that are similar to the tubes 31 and similarly connected but located in the gas passage 15, to the header 13 where it joins the fluid entering through the pipe 12. The mixture passes from the header 13 in parallel through the upper row of tubes 37, each one of which is connected by an end connection to a tube in a lower row, and so on, to the header 38 on the outside of the wall. The tubes 37 are similar to the other tubes in the gas passages already described, but the tubes in each row are connected in parallel instead of the tubes being connected in series. An exit pipe 39 leads from the header 38.

When oil is introduced through the tubes in the radiant heat screen 7, the mixture in the tubes 37 will, of course, be oil. However, when water is introduced through the inlet 3', it is converted into steam and becomes superheated in passing through the tubes of the screen 7, and the mixture entering the header 13 and passing through the tubes 37 may be a mixture of oil vapors and superheated steam.

The operation is as follows: Hot products of combustion from the furnace chamber 5 pass between the tubes in the radiant heat screen 7 and since the tubes in the upper row in this screen are staggered with respect to the tubes in the lower row, the space above this screen is shielded from the most of the radiant heat from the furnace. The gases pass upwardly through the tapering conduits 15, 16 and 17, and thus the velocity or mass flow is kept sufficiently great to cause the rate of heat transmission from the gases to the tubes over which they sweep to be adequate for the desired purpose. This also adds to the efficiency and decreases the necessary surface. The waste gases passing through the air heater 21 heat air that passes into the spaces outside of the conduits 15, 16 and 17, this air finally passing to the furnace for combustion purposes. Other air from the fan 24 may pass through the spaces along the outside of the walls of the furnace 5 and also enter the furnace for combustion purposes.

The oil entering through the inlet pipe 30 passes through the straight tubes extending across the conduits 15, 16 and 17 and flows in a countercurrent direction preferably with sufficiently high velocity through these tubes to produce turbulence, finally entering the header 13 and the oil vapors thereby produced may be joined by vapors or steam from the tubes of the baffle 7, in which case the mixture is further heated by the hottest gases in the conduit 15 and passes out through the outlet 39. The connection from the tubes of the screen 7 may, however, be such that the oil first passes through these tubes to be heated initially, after which this preheated oil

is caused to enter the upper tube 31 in the conduit 17.

It is not necessary to temper the furnace gases, so that the least excess air can be used, because the oil tubes are shielded from the radiant heat of the furnace. High efficiency is possible and the oil is not injured. The system is very suitable for the use of an air heater to recover heat from the waste gases that may be at comparatively high temperatures due to the fact that it was not necessary to cool them appreciably before contacting them with the tubes.

Changes and modifications may be made without departing from the spirit or scope of the invention.

I claim:

1. In an oil still, combustion chamber, gas passages, each of decreasing area with respect to the next passage, and at least one of which passages has a gradually constricted area from entrance to exit leading from said combustion chamber, straight oil tubes connected in series and located in said gas passages, radiantly heated tubes between said straight tubes and said combustion chamber and extending across said combustion chamber, and an oil inlet for said radiantly heated tubes.

2. In an oil still, combustion chamber, gas passages, each of decreasing area with respect to the next passage, and at least one of which passages has a gradually constricted area from entrance to exit leading from said combustion chamber, straight oil tubes connected in series and located in said gas passages, a radiantly heated screen between said combustion chamber and said straight tubes, said screen comprising tubes covered with refractory material and having gas passages between them, and means for passing oil through said radiantly heated screen tubes.

CHARLES E. LUCKE.

110

115

120

125

130