



**AFRICAN REGIONAL INDUSTRIAL PROPERTY
ORGANIZATION (ARIPO)**

<p>(21) Application Number: AP/P/91/00345</p> <p>(22) Filing Date: 18.12.91</p> <p>(24) Date of Grant & (45) Publication 01.12.93</p> <hr/> <p>(30) Priority Data:</p> <p>(33) Country: ZA ZA</p> <p>(31) Number: 90/10178 91/3771</p> <p>(32) Date: 18.12.90 17.05.91</p> <hr/> <p>(84) Designated States:</p> <p>BW ZW</p>	<p>(73) Applicant (s): PETER BALFOUR DUGMORE 4 Swanmore Road Rondebosch, Cape R.S.A. (Assigned in undivided shares)</p> <p>(72) Inventor (s): (see overleaf) PETER BALFOUR DUGMORE 4 Swanmore Road Rondebosch, Cape R.S.A.</p> <p>(74) Representative: GEORGE SEIRLIS & ASSOCIATES P. O. BOX 3568 HARARE ZIMBABWE</p>
---	---

(51) International Patent Classification Int. Cl.⁵ **H01R 4/24, 4/30**

(54) Title: **ELECTRICAL CONNECTOR**

(57) Abstract **An electrical connector for forming an electrical connection between a conductive terminal (10) and an insulated electrical wire (44) includes a channel (40) sized to accommodate the wire. Piercing means (22) is arranged to be positioned over the channel and in electrical contact with the terminal. Clamping means (28) is used to urge the piercing means towards the wire to cause the piercing means to pierce the wire and thereby provide electrical contact between the wire and the terminal.**

AP 292

BAD ORIGINAL



2. PAUL BUNN
3 Riverdale
Laurensford Road
Somerset West
Cape Province
REPUBLIC OF SOUTH AFRICA

3. GWENDY HELEN HAYWARD
402 Rusdon Park
College Road
Rondebosch
Cape Province
REPUBLIC OF SOUTH AFRICA

BACKGROUND OF THE INVENTION

This invention relates to an electrical connector, and in particular to an electrical connector for forming an electrical connection between an insulated electrical wire and the pin of an electric plug.

The connection of the individual insulated electrical wires to the pin terminals of a three pin domestic plug can be a laborious and time-consuming process. The insulation has to be stripped from the ends of each of the individual wires using a suitable tool such as an insulation stripper or a knife. The conductive cores then have to be prepared for subsequent insertion and clamping by a screw at the head of each pin. During this process, the conductive core may get damaged, as several strands of the core may be inadvertently cut while the insulation is being stripped from the end of the insulated wire. Moreover, a stripping tool is required to strip the insulation from the core, and a screwdriver is required to tighten the screw up against the core.

SUMMARY OF THE INVENTION

According to the invention there is provided an electrical connector for forming an electrical connection between a conductive terminal and an insulated electrical wire comprising a channel sized to accommodate an end portion of the insulated electrical wire, piercing means arranged to be positioned over the channel in electrical contact with the terminal, clamping means for urging the piercing means towards the channel, and causing the piercing means to pierce through the insulation of the wire so as to provide electrical contact between the terminal and the conductive core of the insulated electrical wire, and actuating means for tightening and loosening the clamping means, the actuating means being carried on a housing which houses the electrical connector.

Preferably, the clamping means comprises a threaded shaft extending axially



from a fixed end of the terminal, and a complementally threaded nut which screws onto the shaft.

The actuating means conveniently comprises a socket which is complementary with the nut and which is formed integrally with the housing.

The piercing means advantageously comprises an annular ring having a plurality of axially extending spikes spaced around the ring.

The terminal may comprise an electrically conductive pin which forms part of an electrical plug.

In a preferred form of the invention, the channel is annular in form, and extends around the outer periphery of the terminal.

Preferably, the channel is defined by the conductive terminal and a recess in a base to which one end of the conductive terminal is mounted.

The conductive terminal advantageously comprises a pin having a platform towards the fixed end of the pin which locates within a lower complementary portion of the recess and a threaded shaft of lesser cross sectional area than the platform extending therefrom, the channel being defined by the upper surface of the platform, the shaft and an upper portion of the recess.

Alternatively, the channel may be formed integrally with and of the same material as the pin.

The invention extends to an electrical plug comprising a housing having a base, a lid, a plurality of terminal pins extending from the base and connection means for connecting lengths of insulated wire to each of the pins, the connection means comprising a channel surrounding the end of each pin and sized to accommodate the ends of the lengths of insulated wire, piercing



means being in electrical contact with each terminal pin, and clamping means for urging the piercing means towards the channel and for causing the piercing means to pierce through the insulation of each wire.

Actuating means are conveniently provided for operating the clamping means, the actuating means being formed integrally with the plug lid.

BRIEF DESCRIPTION OF THE DRAWINGS

- Figure 1 shows an exploded partly cross-sectional side view of an electrical connector of the invention;
- Figure 1A shows an underplan view of a piercing element illustrated in Figure 1;
- Figure 2 shows a half assembled partly cross-sectional side view of the electrical connector of Figure 1;
- Figure 3 shows a fully assembled partly cross-sectional side view of the electrical connector of Figures 1 and 2;
- Figure 4 shows a top plan view of a plug lid forming part of the invention;
- Figure 5 shows a cross-section on the line 5-5 of figure 4, and
- Figure 6 shows a top plan view of the base of an electrical plug of the invention to which the lid of Figure 4 fits.

DESCRIPTION OF EMBODIMENTS

The electrical connector illustrated in Figure 1 includes an earth pin 10 of a



three pin electrical plug. A threaded shaft 12, extends from a platform 14 located at the fixed end of the pin. Both the shaft 12 and the platform 14 are co-axial with the central axis 16 of the pin, and the platform 14 has a slightly greater diameter than the pin body 10.

The pin is sized to engage a complementary aperture 18 formed in the front end of the base 20 of a plug housing. A piercing element, in the form of an annular washer 22, has four equi-spaced spikes 24 protruding from its lower surface, as can be seen more clearly in Figure 1A. Each spike has an arcuate cutting edge 26. Clamping means are provided by a threaded hex nut 28 which is able to screw down onto the threaded shaft 12.

Referring now to Figure 2, the terminal pin 10 is located snugly within the complementary aperture 18, with the platform 14 of the pin nesting within a stepped recess 30 formed within the aperture 18. A notch 32 formed just beneath the platform 14 serves both to prevent rotation of the pin 10 and to lock it axially in a snap fit against the lowermost cylindrical portion 34 of the aperture 18. A frusto-conical shoulder 36 extends between a cylindrical upper opening 38 of the aperture and the stepped recess 30.

As can be seen in Figure 2, the upper surface of the platform 14, the outer surface of the threaded shaft 12, the frusto-conical shoulder 36 and the cylindrical opening 38 define in combination an annular channel surrounding the threaded shaft 12. The annular channel 40 is clearly shown in Figure 6, in which the entire base 20 of the plug housing is depicted.

In order to form an electrical connection between the earth lead 44 of a three-core cable 46, the end of the lead 44 is wrapped around the shaft 12 within the channel 40. No stripping of the insulation from the end of the lead 44 needs to take place. As is clear from Figure 2, the channel 40 is sized to accommodate the lead 44 in a snug fit. With the lead in position, the piercing element 22 is then passed over the threaded shaft 12. In this position, the

spikes 24 point in a downward direction parallel to the central axis 16, with the spike edges 26 resting on the insulation of the lead 44. The nut 28 is then threaded down over the shaft 12 and finger-tightened.

As can be seen in Figure 4, the base of the plug 20 has a corresponding lid 46. The lid has a hex socket 48 moulded into the upper surface 50 of the lid 46 towards the front end thereof. The socket 48 is sized to fit snugly around the nut 28. In order to tighten the nut 28 further, the detached plug top 46 is inverted and the socket 48 is engaged with the nut 28. As the socket is located towards the front end of the plug top 46, the rear end of the plug top 46, when gripped, serves as a lever arm to achieve sufficient tightening of the nut.

As the nut 28 is tightened down over the shaft 12, the spikes 24 on the piercing element are urged downwardly into the insulation 52 of the lead. In the fully tightened position indicated in Figure 3, the spikes 24 have pierced the insulation 52 through to the core 54 of the lead, with which they form an electrical contact. The effectiveness of the electrical contact is ensured both by the number of spikes 24 and by the length of the arcuate cutting edges 26 of each spike. The aperture of the washer is sized to fit snugly over the threaded shaft 12, and outer periphery of the washer is dimensioned to locate complementally within the cylindrical opening 38 of the aperture. The spikes 24 are thus guided directly over the core 54 of the lead. In order to prevent over tightening, the extent of downward travel of the washer is limited by the depth of the cylindrical opening 38.

The live and neutral leads 56 and 58 of the three core cable 46 are connected to their respective live and neutral pins 60 and 62 in exactly the same fashion as was described with reference to the earth pin 10.

A major advantage of the electrical connector of the invention is that it facilitates the connection of an insulated wire to an electrically conductive pin



without the need to strip the wire beforehand. In addition, an electrical plug of the invention can be wired up without the need to use any separate tools. The individual leads do not require stripping, and the leads are clamped into electrical contact with the pins using the integrally moulded socket on the plug lid.

CLAIMS

1. An electrical connector for forming an electrical connection between an conductive terminal and an insulated electrical wire comprising a channel sized to accommodate an end portion of the insulated electrical wire, piercing means arranged to be positioned over the channel, in electrical contact with the terminal, clamping means for urging the piercing means towards the channel, and causing the piercing means to pierce through the insulation of the wire so as to provide electrical contact between the terminal and the conductive core of the insulated electrical wire, characterized in that actuating means are provided for tightening and loosening the clamping means, the actuating means carried on a housing which houses the electrical connector.
2. An electrical connector as claimed in claim 1 in which the clamping means comprising a threaded shaft extending axially from a fixed end of the terminal, and a complementally threaded nut which screws onto the shaft.
3. An electrical connector as claimed in claim 2 in which the actuating means comprising a socket which is complemental with the nut and which is formed integrally with the housing.
4. An electrical connector as claimed in any one of the preceding claims in which the piercing means comprising an annular ring having a plurality of axially extending spikes spaced around the ring.
5. An electrical connector as claimed in any one of the preceding claims in which the terminal comprises an electrically conductive pin which forms part of an electrical plug.



6. An electrical connector as claimed in any one of the preceding claims in which the channel is annular in form, and extends around the outer periphery of the terminal.
7. An electrical connector as claimed in any one of the preceding claims in which the channel is defined by the conductive terminal and a recess in a base to which one end of the conductive terminal is fixed.
8. An electrical connector as claimed in claim 7 in which the conductive terminal comprises a pin having a platform towards the fixed end of the pin which locates within a lower complementary portion of the recess, and a threaded shaft of lesser cross sectional area than the platform extending therefrom, the channel being defined by the upper surface of the platform, the shaft and an upper portion of the recess.
9. An electrical connector as claimed in any one of claims 1 to 6 in which the channel is formed integrally with and of the same material as the pin.
10. An electrical plug comprising a housing having a base, a lid, a plurality of terminal pins extending from the base, and connection means for connecting lengths of insulated wire to each of the pins, the connection means comprising a channel surrounding the end of each pin and sized to accommodate the ends of the lengths of insulated wire, piercing means being in electrical contact with each pin, and clamping means for urging the piercing means towards the channel and for causing the piercing means to pierce through the insulation of the wire.
11. An electrical plug as claimed in claim 10 in which actuating means are provided for operating the clamping means, the actuating means being formed integrally with the plug lid.

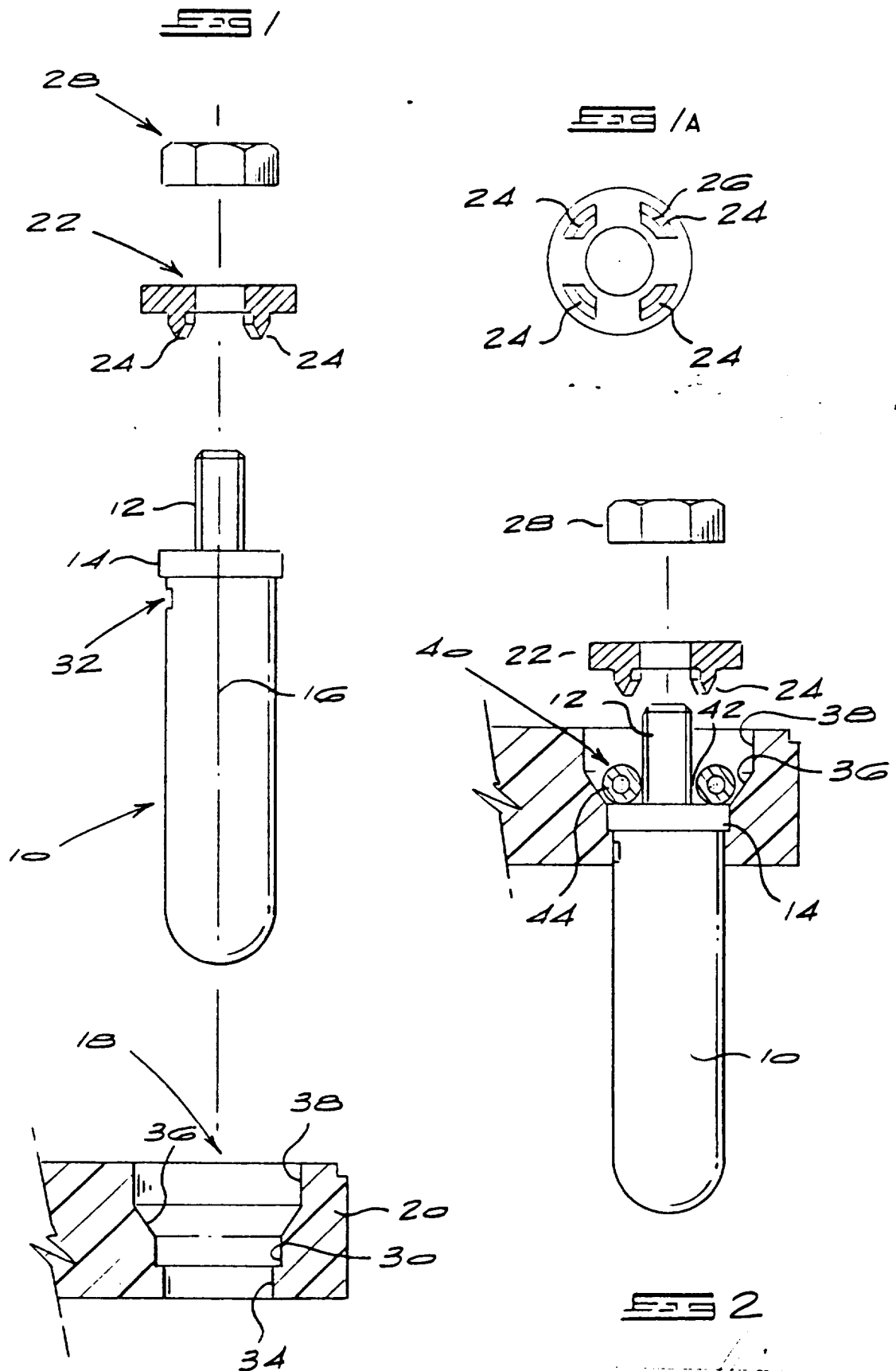

[Handwritten signature]
INVENTOR



FIG 3

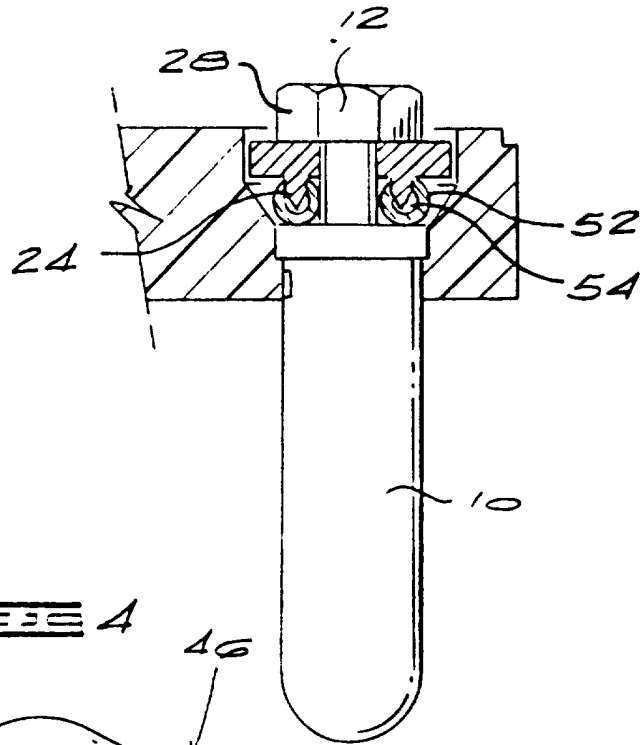

FIG 4

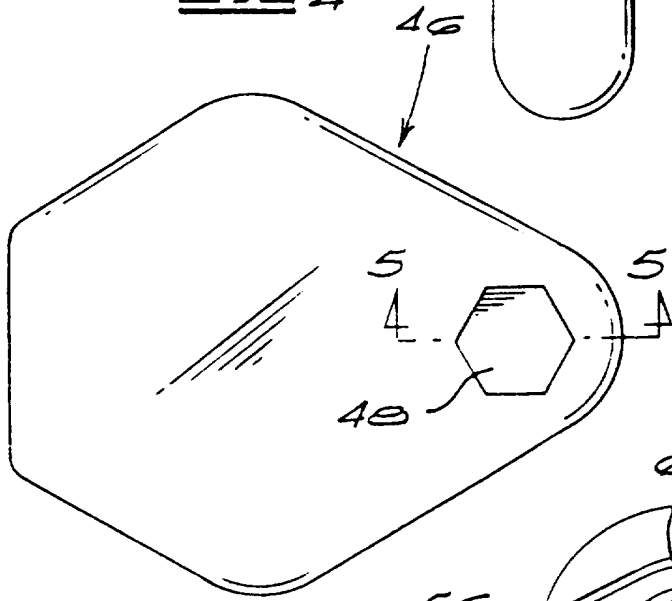

FIG 5

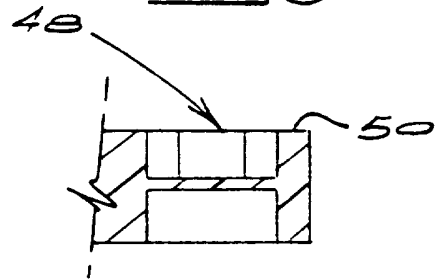
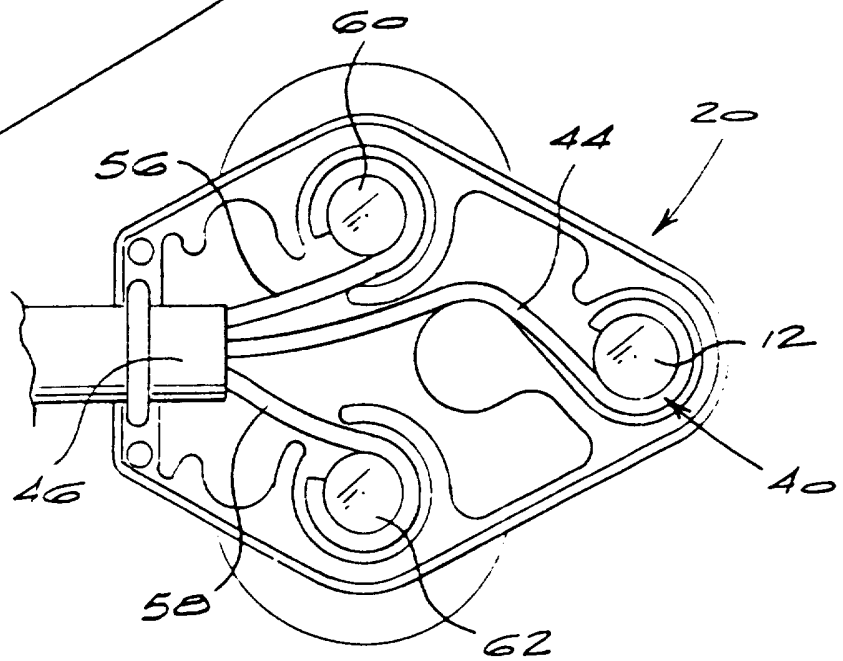

FIG 6



BAD ORIGINAL 

AP 000292

~~SECRET~~
SECRET
SECRET

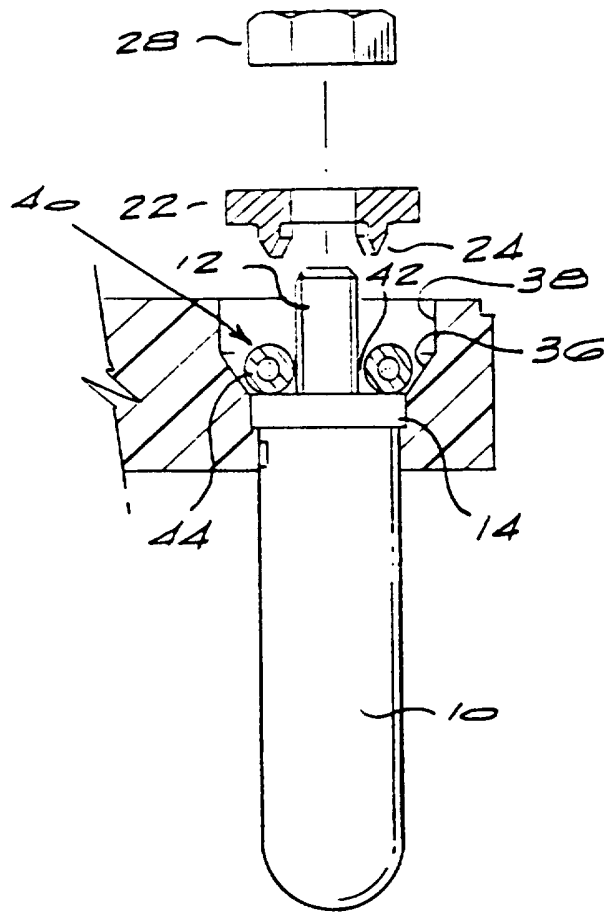

[Handwritten signature]

BAD ORIGINAL

