

May 14, 1968

R. E. SCHROTER

3,383,473

BI-DIRECTIONAL TAPE TRANSPORT

Filed Feb. 27, 1963

11 Sheets-Sheet 1

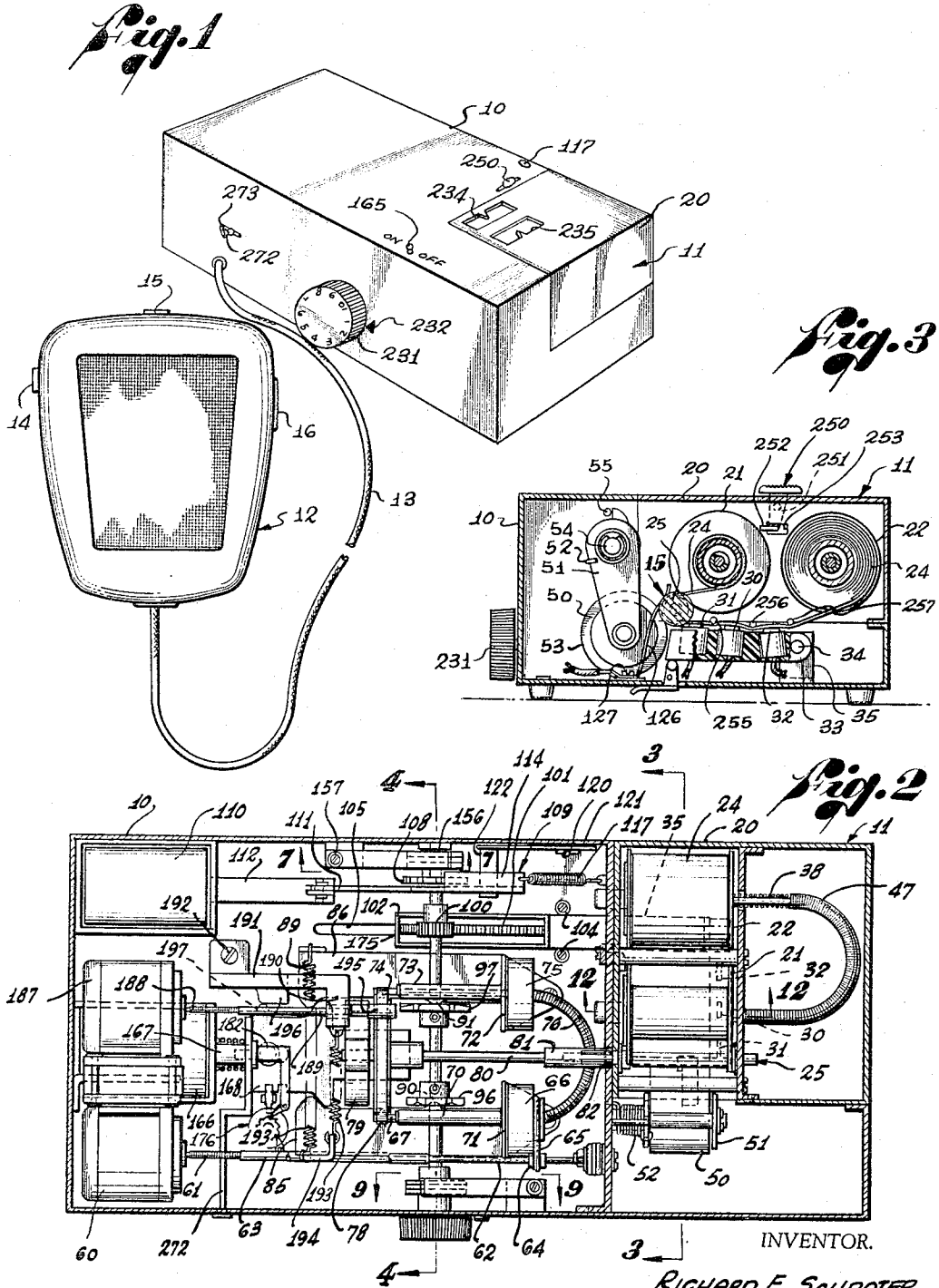

INVENTOR.
RICHARD E. SCHROTER
BY *Fulcrum & Huntley*
Attorneys

May 14, 1968

R. E. SCHROTER

3,383,473

BI-DIRECTIONAL TAPE TRANSPORT

Filed Feb. 27, 1963

11 Sheets-Sheet 2

Fig. 4

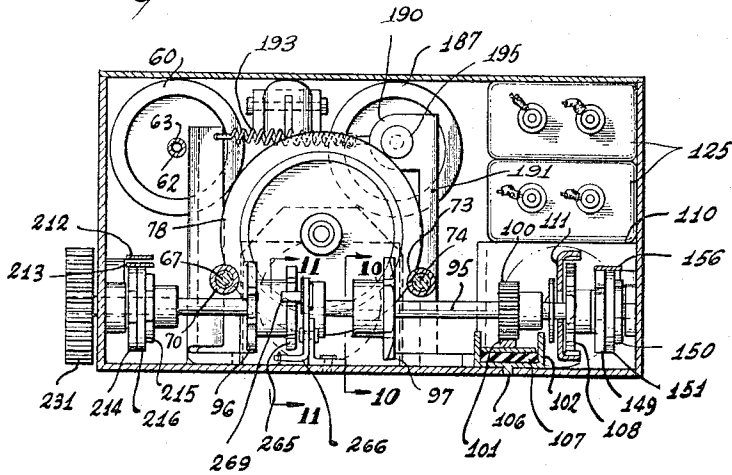

Fig. 5

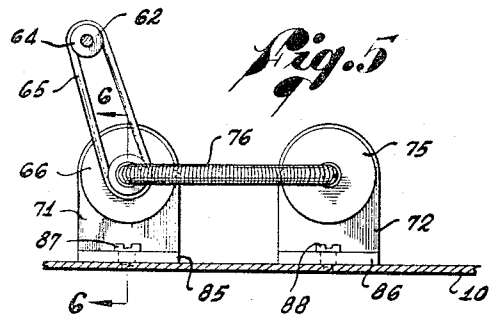

Fig. 6

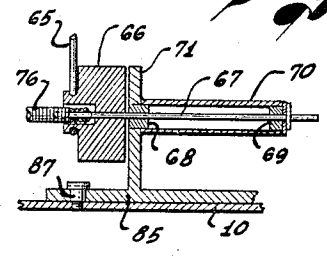

Fig. 7

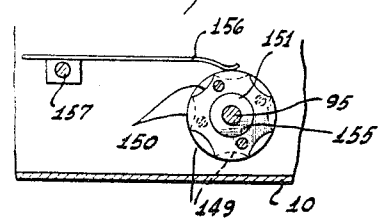

Fig. 8

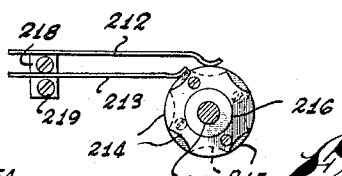
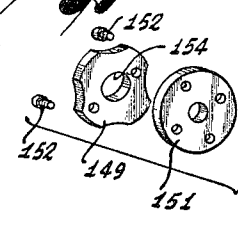

Fig. 9

Fig. 10

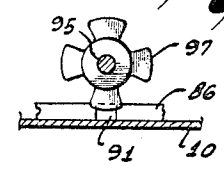
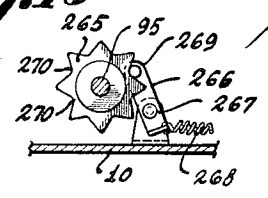

Fig. 11



INVENTOR.
 RICHARD E. SCHROTER
 BY *Fulwider Mattingly & Huntley*
 Attorneys

May 14, 1968

R. E. SCHROTER

3,383,473

BI-DIRECTIONAL TAPE TRANSPORT

Filed Feb. 27, 1963

11 Sheets-Sheet 3

Fig. 12

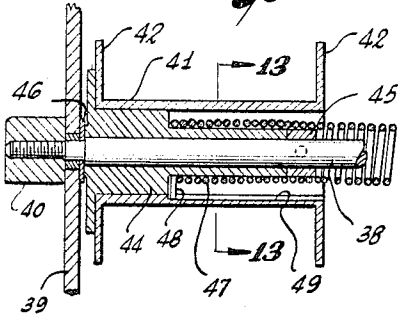

Fig. 13

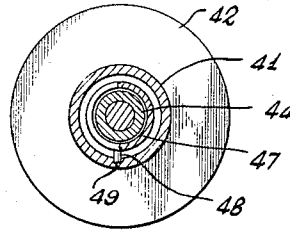

Fig. 14

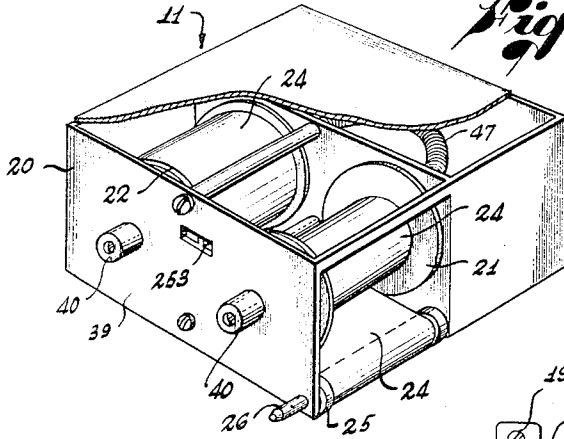

Fig. 15

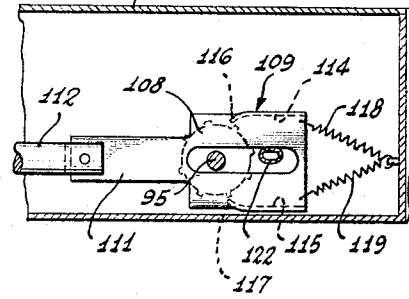

Fig. 16

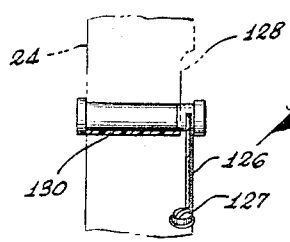

Fig. 18

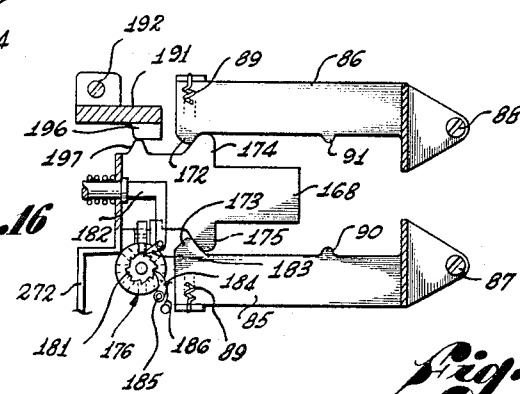

Fig. 19

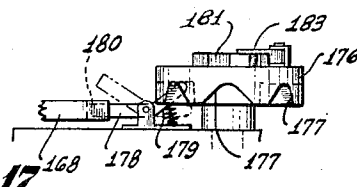
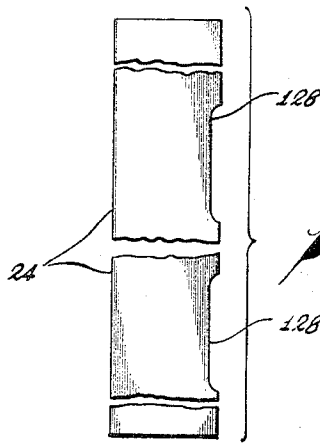

Fig. 17



INVENTOR.
RICHARD E. SCHROTER
BY *Lukwider Mattingly & Huntley*
Attorneys

May 14, 1968

R. E. SCHROTER

3,383,473

BI-DIRECTIONAL TAPE TRANSPORT

Filed Feb. 27, 1963

11 Sheets-Sheet 4

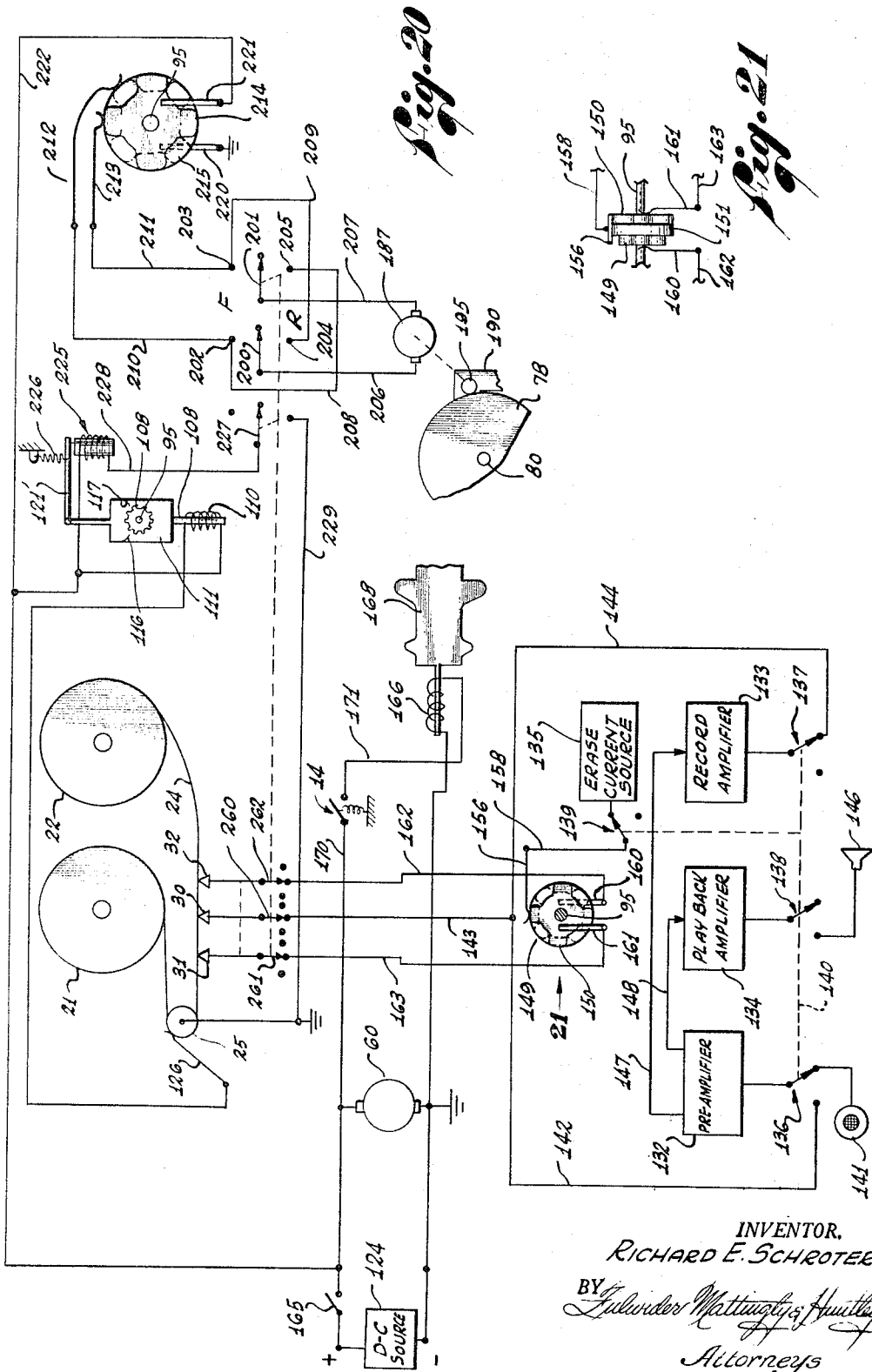

Fig. 20

Fig. 21

INVENTOR.
RICHARD E. SCHROTER
BY *Lullinder Mattingly & Huntley*
Attorneys

May 14, 1968

R. E. SCHROTER

3,383,473

BI-DIRECTIONAL TAPE TRANSPORT

Filed Feb. 27, 1963

11 Sheets-Sheet 5

Fig. 22

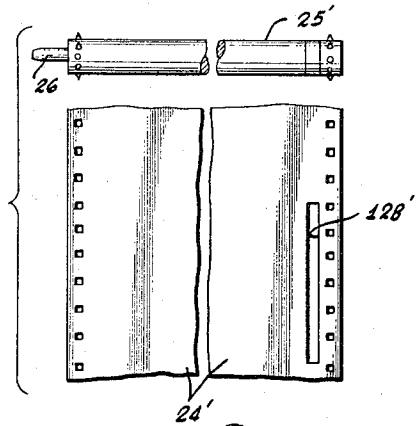
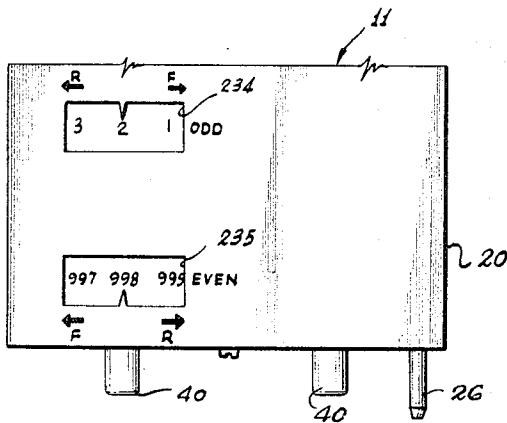
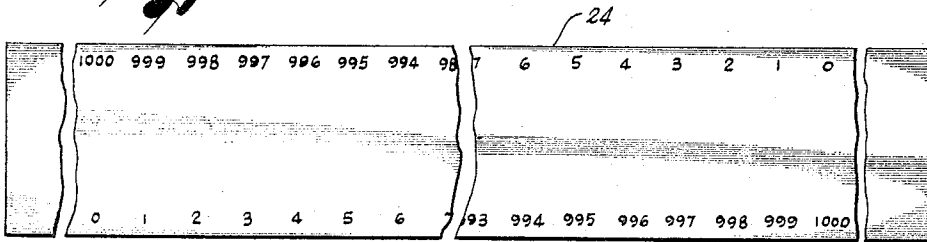

Fig. 24

Fig. 23

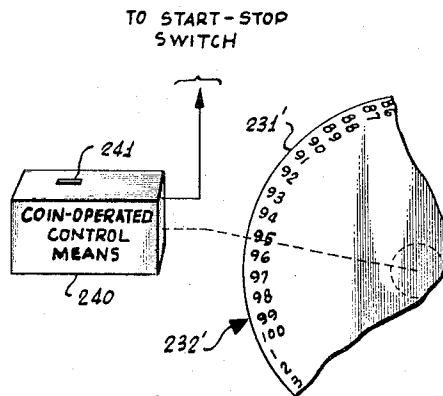

Fig. 25

INVENTOR.

RICHARD E. SCHROTER

BY *Ludwigo Martingale Huntley*
Attorneys

May 14, 1968

R. E. SCHROTER

3,383,473

BI-DIRECTIONAL TAPE TRANSPORT

Filed Feb. 27, 1963

11 Sheets-Sheet 6

Fig. 26

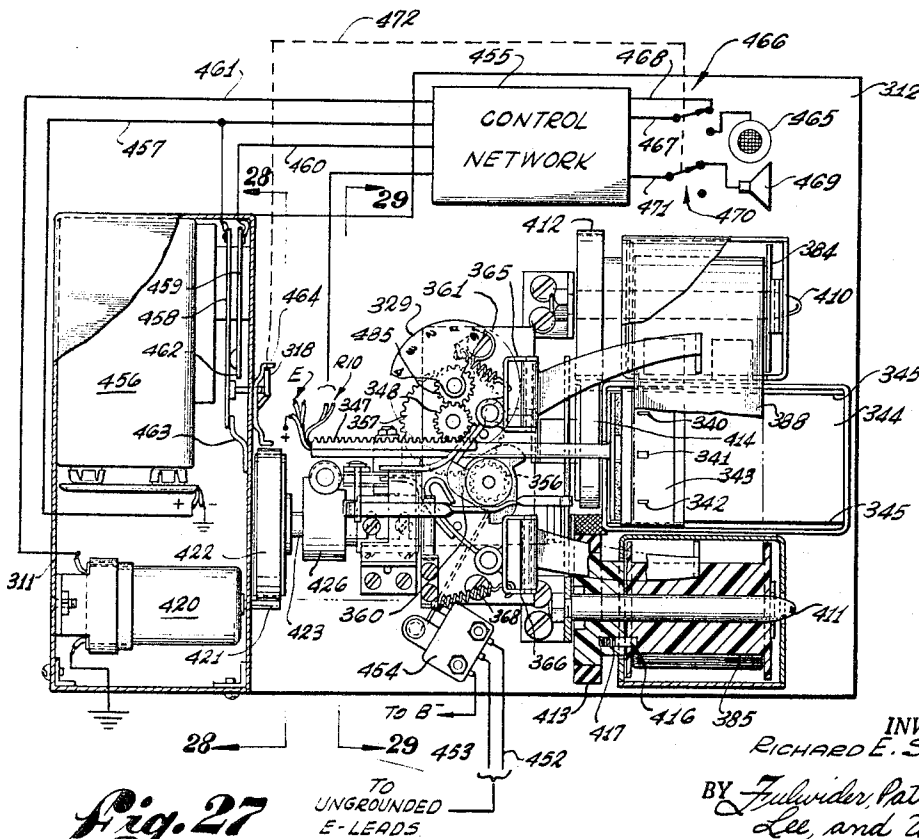
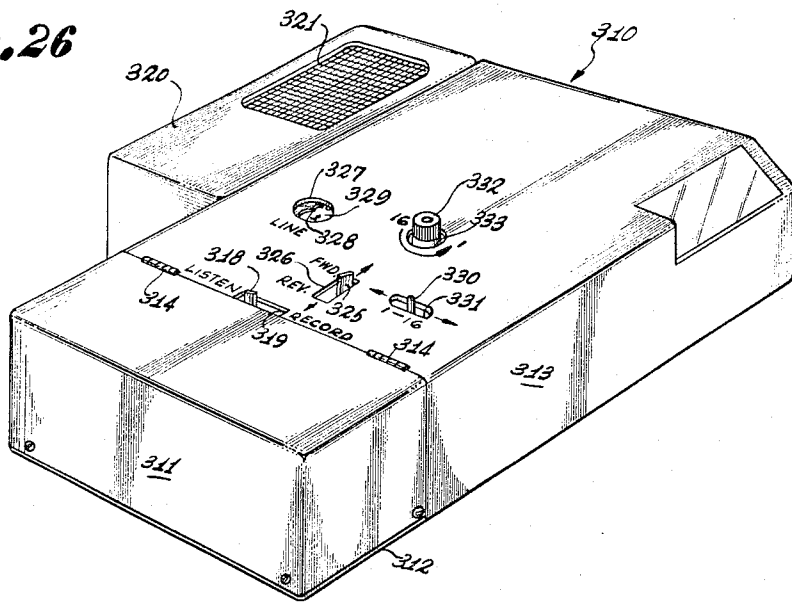

Fig. 27

TO B-
-29 453
TO UNGROUNDED
E-LEADS

INVENTOR.
RICHARD E. SCHROTER
BY Fulwider, Patton, Rieber
Lee, and Uecht
ATTORNEYS

May 14, 1968

R. E. SCHROTER

3,383,473

BI-DIRECTIONAL TAPE TRANSPORT

Filed Feb. 27, 1963

11 Sheets-Sheet 7

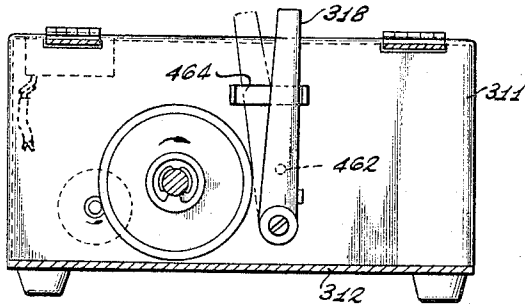

Fig. 28

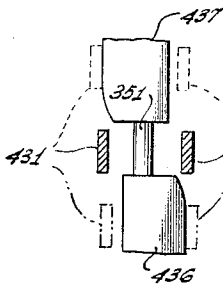

Fig. 33

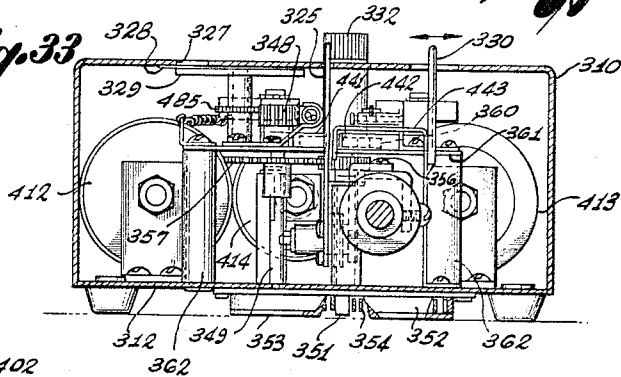

Fig. 29

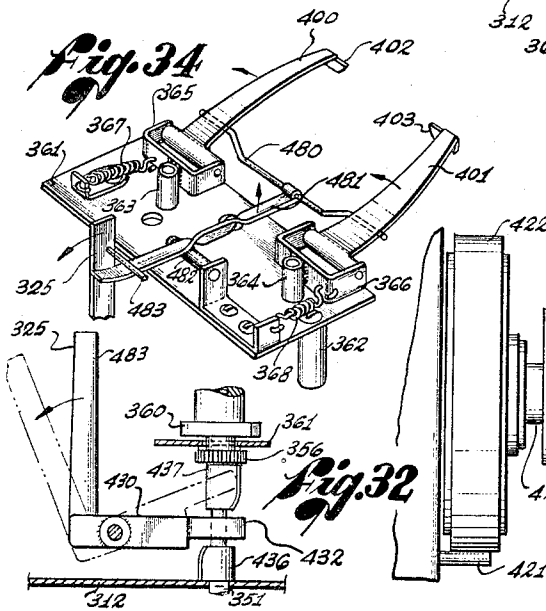

Fig. 34

Fig. 32

Fig. 31

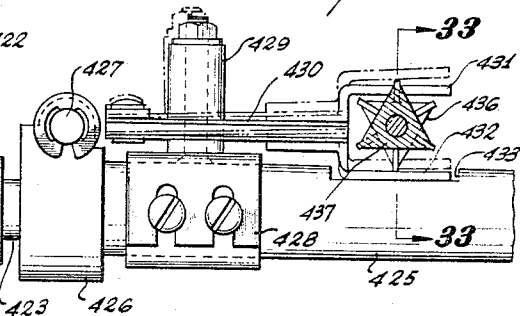
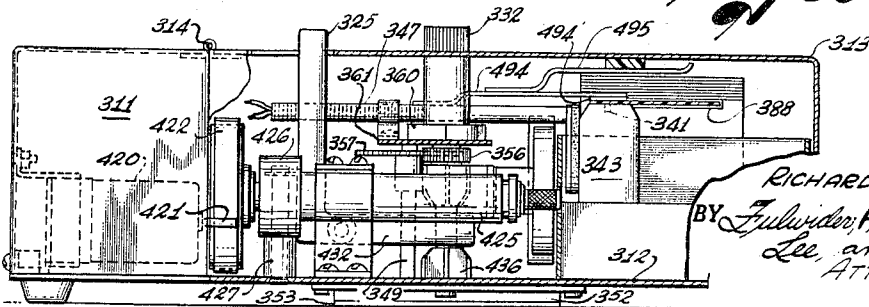

Fig. 30



INVENTOR.

RICHARD E. SCHROTER

BY Fulwider, Patton, Reber,
Lee, and Utecht
ATTORNEYS

May 14, 1968

R. E. SCHROTER

3,383,473

BI-DIRECTIONAL TAPE TRANSPORT

Filed Feb. 27, 1963

11 Sheets-Sheet 8

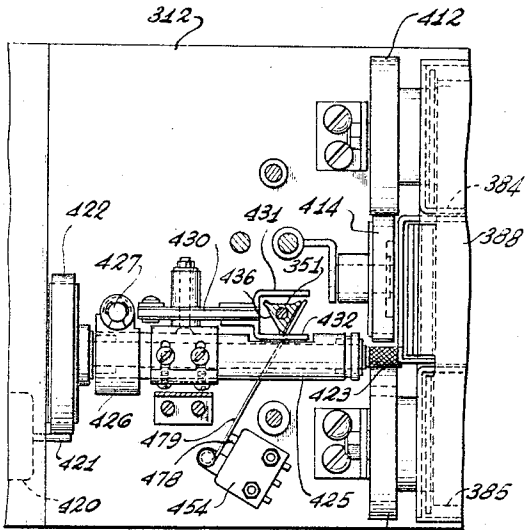

Fig. 35
413

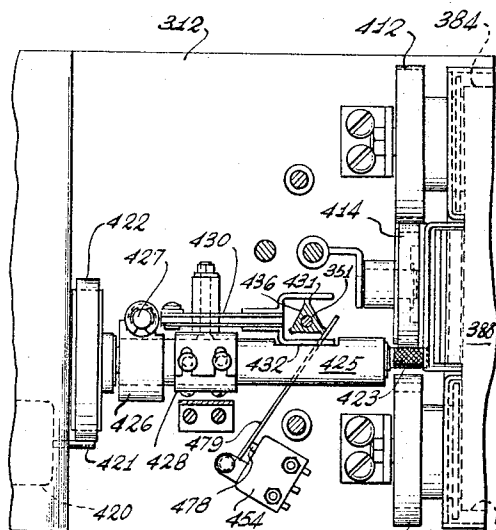

Fig. 36
385
413

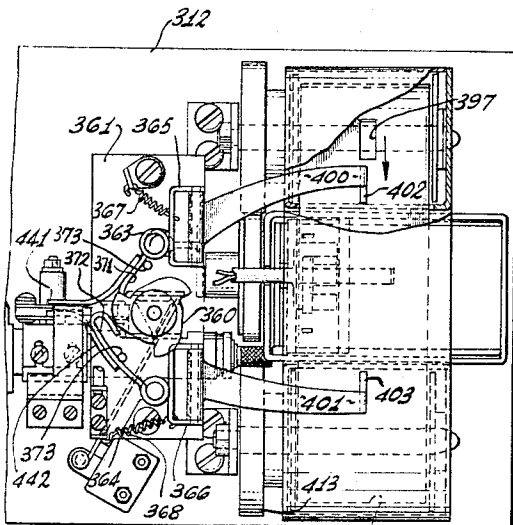

Fig. 37
385

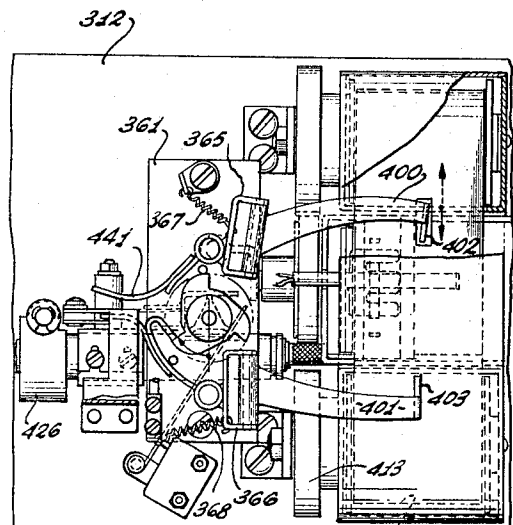

Fig. 38
385

INVENTOR.
RICHARD E. SCHROTER
BY *Julius, Patton, Riebers,
Lee, and Utcht*
ATTORNEYS

May 14, 1968

R. E. SCHROTER

3,383,473

BI-DIRECTIONAL TAPE TRANSPORT

Filed Feb. 27, 1963

11 Sheets-Sheet 9

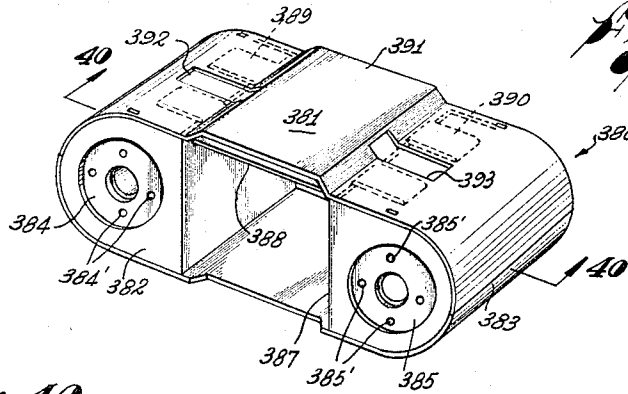

Fig. 39

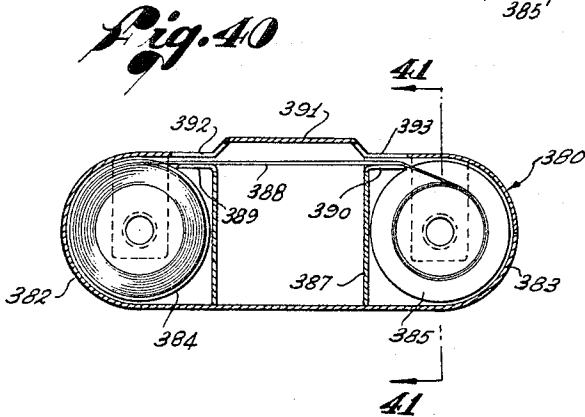

Fig. 40

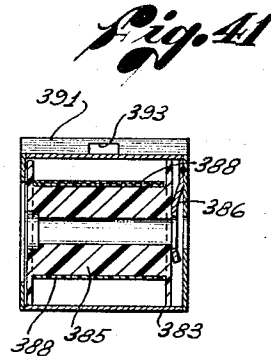

Fig. 41

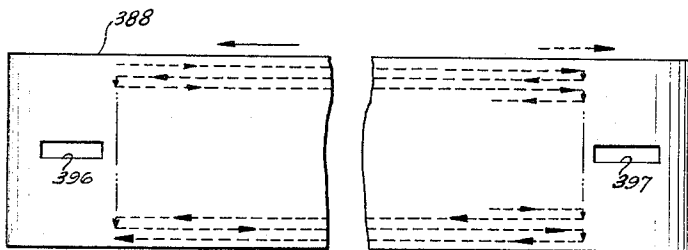

Fig. 43

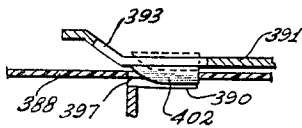

Fig. 42

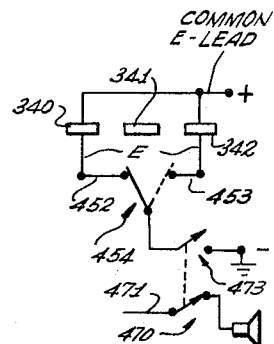

Fig. 44

INVENTOR.
 RICHARD E. SCHROTER
 BY *Zulwiler, Patton, Rieber,
 Le, and Uecht*
 ATTORNEYS

May 14, 1968

R. E. SCHROTER

3,383,473

BI-DIRECTIONAL TAPE TRANSPORT

Filed Feb. 27, 1963

11 Sheets-Sheet 10

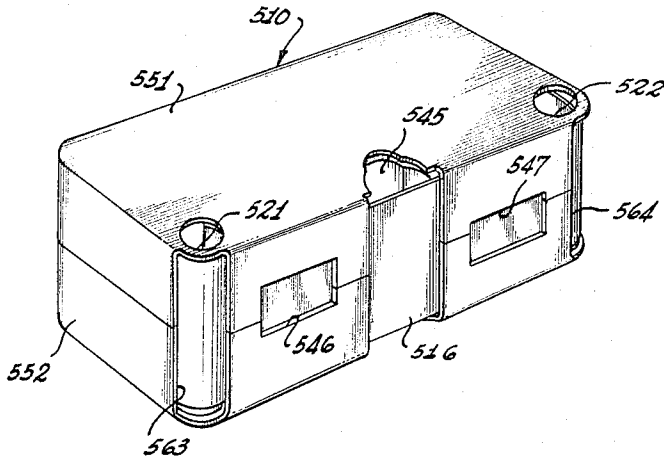
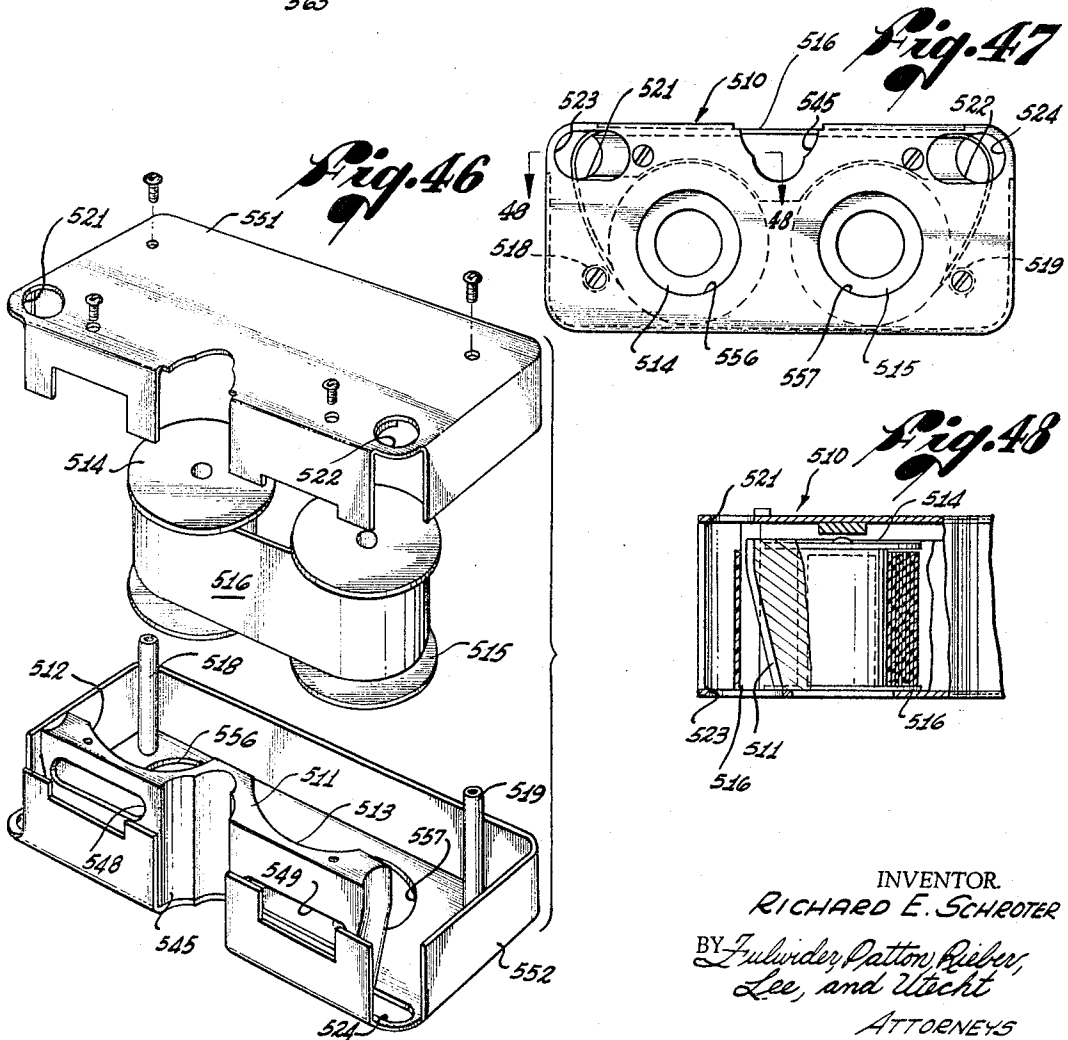

Fig. 45



INVENTOR
RICHARD E. SCHROTER
BY *Inulwider, Patton, Fisher,
Lee, and Uecht*
ATTORNEYS

May 14, 1968

R. E. SCHROTER

3,383,473

BI-DIRECTIONAL TAPE TRANSPORT

Filed Feb. 27, 1963

11 Sheets-Sheet 11

LINKAGE TO ARM 430

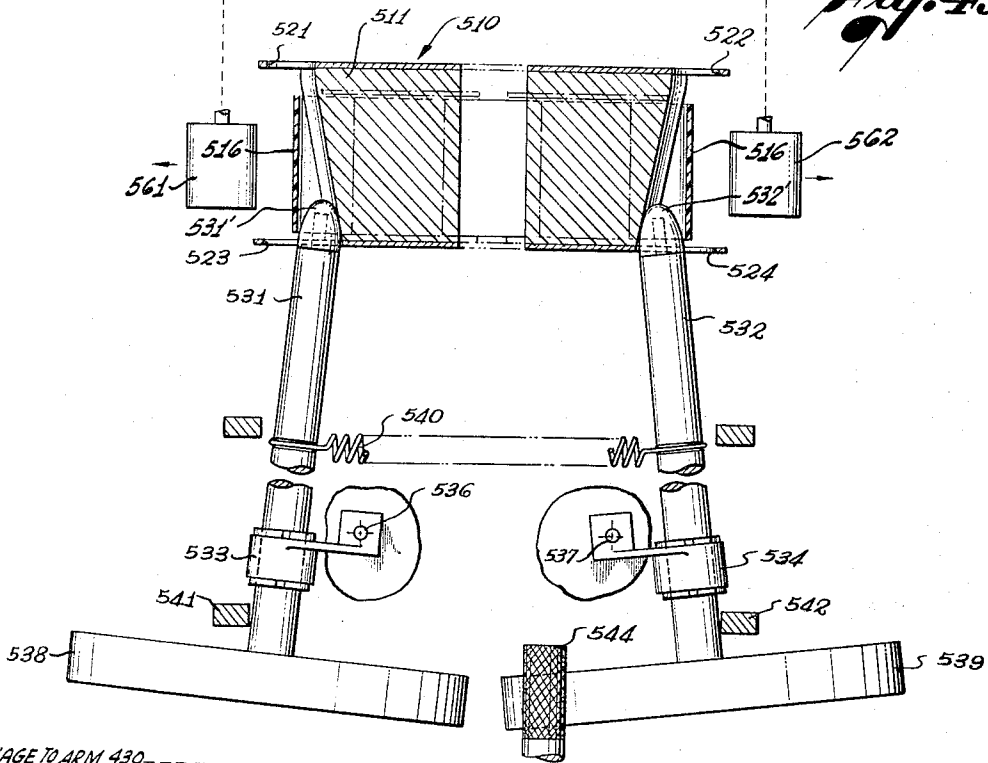

Fig. 49

LINKAGE TO ARM 430

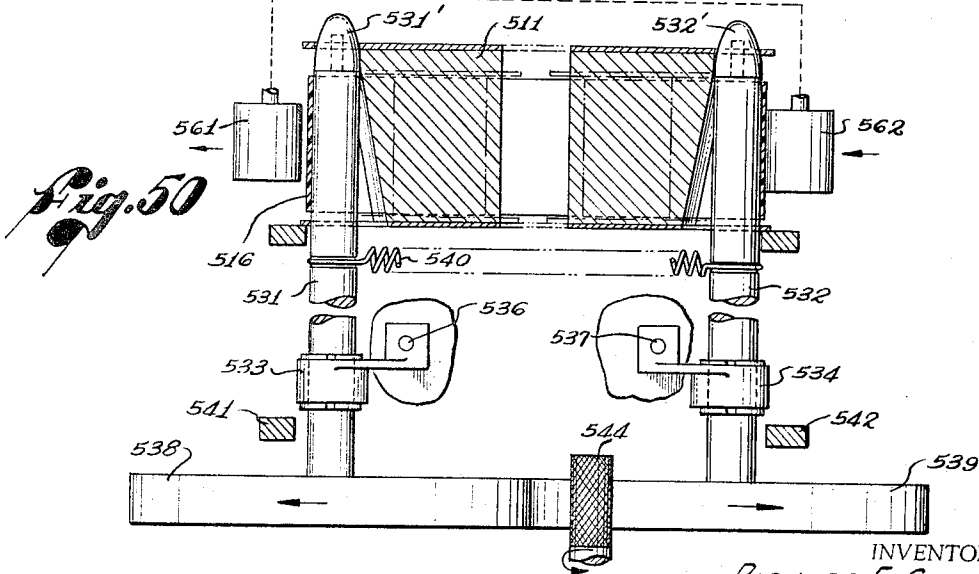

Fig. 50

INVENTOR.
RICHARD E. SCHROTER
BY *Fulwider, Patton, Ribben,
Lee, and Utecht*
ATTORNEYS

1

3,383,473

BI-DIRECTIONAL TAPE TRANSPORT

Richard E. Schroter, Hollywood, Calif., assignor to
Ralph J. Samuels, Los Angeles, Calif.

Continuation-in-part of application Ser. No. 803,490,
Apr. 1, 1959. This application Feb. 27, 1963, Ser.
No. 261,953

12 Claims. (Cl. 179—100.2)

This application is a continuation-in-part of my copending application, Tape recorder and Reproducer, Ser. No. 803,490 filed Apr. 1, 1959, and now abandoned.

As is well known, prior art tape recorders have long been criticized as being unduly bulky and heavy, or undesirably expensive to produce, or both. Many attempts have been made in the past to develop miniature tape recorders, but it has generally been found that the smaller tape recorders having the recording and reproducing qualities of larger ones cannot be made without resort to unduly expensive and complex circuits and components.

Prior attempts to provide compact tape recorders have resulted in failure to produce one utilizing a short length of tape and having the recording time of larger recorders, and still characterized by extreme simplicity of design and economy of manufacture. In short, what has been lacking is a tape recorder to fill the demands of consumers for an inexpensive, small, lightweight, high quality tape recording unit with which recording time is comparable to that of the presently known bulky recorders.

Tape recorders as heretofore known have generally been unsatisfactory for the recording and reproduction of music, in spite of the fact that tape is recognized as a superior medium to phonograph records for the recording of music. One reason is that the tape must be handled, and in the process becomes soiled and is subjected to tearing or other deformation which results in an impairment of the continuity or quality of music reproduced therefrom. And high quality music reproduction has been non-existent in miniature recorders using short lengths of tape, a result which in part occurs from the dilemma of required high tape speeds for music.

It is an object of this invention to provide an improved magnetic tape recorder which overcomes the above and other disadvantages of prior art tape recorders.

Another object of this invention is to provide an improved tape recorder which is smaller in size and lighter in weight than prior art tape recorders, yet which provides as much playing time as can be realized with large and unwieldy reels of tape.

A further object of this invention is to provide an improved tape recorder of small and compact size which utilizes removable cartridges of magnetic tape, wherein the tape never has to be handled in any manner.

It is a further object of this invention to provide an improved tape recorder utilizing a small removable cartridge of magnetic tape, in which multiple lane recording is utilized to provide recording time comparable to that obtained heretofore only with large and unwieldy reels of tape.

An additional object of this invention is to provide a tape recorder having a removable tape cartridge which is self-locating on the main housing of the recorder so as to be automatically positioned for operative engagement with drive means for the tape.

A still further object of this invention is to provide an improved tape recorder which utilizes a single recording head for multiple track recording on the same surface of a width of tape, and wherein any portion of any track can be rapidly and positively located adjacent the head.

Still another object of this invention is to provide a unique electro-mechanical structure for relatively shifting the position of the recording head transversely along a

2

magnetic tape for recording sounds along multiple lanes of the tape.

An additional object of this invention is to provide a unique miniature tape recorder which uses a short length of tape but is still capable of high quality recording and reproduction of music at high tape speeds.

The above and other objects and advantages of this invention will become apparent from the following description taken in conjunction with the accompanying drawings of illustrative embodiments thereof; in which:

FIGURE 1 is a perspective view of one embodiment of a tape recorder having a plug-in tape cartridge in accordance with my invention;

FIGURE 2 is a sectional view of the recorder of FIGURE 1, showing the means for operating the tape and the record-listen and erase heads;

FIGURE 3 is a sectional view taken along the line 3—3 of FIGURE 2, showing the relative positions of the reels and the capstan in the cartridge, and the positions of the record and erase heads against the tape;

FIGURE 4 is a sectional view taken along the line 4—4 of FIGURE 2, showing normal and high speed drive motors, and showing the main control shaft having both manual and electromechanically actuatable means for effecting its rotation to move the record-listen and erase heads, and also showing the arrangement of cams on the control shaft utilized for controlling the direction of rotation of the capstan;

FIGURE 5 is an end elevation view of the flywheels used for the capstan drive, showing their interconnection for operation in opposite directions;

FIGURE 6 is a fragmentary sectional view taken along the line 6—6 of FIGURE 5, showing how the shaft on which the flywheel is mounted is adapted for rotation in its movable support;

FIGURE 7 is a side elevation view taken along the line 7—7 of FIGURE 2, showing the arrangement of a contact and contact element for use in controlling the electrical operation of the erase heads;

FIGURE 8 is an exploded view of the parts of the contact of FIGURE 7;

FIGURE 9 is an end elevational view taken along the line 9—9 of FIGURE 2, showing a contact element cooperatively related with respective contacts affixed to the housing for effecting reversal of the direction of the tape with the high speed motor;

FIGURE 10 is a fragmentary sectional view taken along the line 10—10 of FIGURE 4, showing the shape of the cam elements used in conjunction with the drive shafts for operating the capstan drive;

FIGURE 11 is a fragmentary sectional view taken along the line 11—11 of FIGURE 4, showing the snap action detent arrangement for positively locating the record-listen and erase heads in the center of a track;

FIGURE 12 is a fragmentary sectional view taken along the line 12—12 of FIGURE 2, showing the construction of the reels or spindles employed in the cartridge;

FIGURE 13 is a sectional view taken along the line 13—13 of FIGURE 12, showing how the end of a coil spring for tensioning the tape is removably secured to the interior of a spindle;

FIGURE 14 is a perspective view of the tape plug-in unit, partially broken away to show the disposition therein of the reels and the capstan, and showing the locating pins on the ends of the shaft on which the reels are mounted for insuring the proper positioning of the plug-in unit of the main housing;

FIGURE 15 is a fragmentary sectional view of the solenoid-operated rack and pinion structure for rotating the main control shaft to shift the record-listen and erase heads at the end of each track on the tape, and showing

the disposition of the ratchet detent structure for controlling the direction in which the main control shaft is turned;

FIGURE 16 is a fragmentary sectional view of the capstan, showing the location at one end of a metal portion to be exposed for contact at the end of a track for effecting energization of the solenoid;

FIGURE 17 is a fragmentary plan view of the tape, showing how it is partially cut away at the sides adjacent its ends to insure that the metal portion of the capstan will be exposed at the proper moment for shifting the record-listen and erase heads;

FIGURE 18 is a fragmentary top plan view of the solenoid-operated mechanism for stop-start control, and showing a ratchet and cam mechanism for manual stop-start control;

FIGURE 19 is an enlarged end view of the ratchet and cam mechanism of FIGURE 18;

FIGURE 20 is a combined schematic and block diagram of electrical control means for synchronizing the desired operations of the motors, the tape, and the record-listen and erase heads;

FIGURE 21 is an elevational view taken along the line 21—21 of FIGURE 20, showing how the rotatable contact elements are arranged for alternately connecting the erase heads to the erase current source;

FIGURE 22 is a fragmentary plan view of the tape numbered so as to aid the operator in determining the direction of travel thereof;

FIGURE 23 is an enlarged top plan view of the tape cartridge, showing window openings to permit the operator to see the number indications;

FIGURE 24 is a fragmentary plan view of a capstan and tape arranged for moving the tape by sprocket drive;

FIGURE 25 is a schematic diagram of coin-operated control means for operating a music reproducing unit;

FIGURE 26 is a perspective view of another embodiment of a completely self-contained, pocket-sized tape recorder of my invention, showing the accessibility of various controls externally of the housing for operating the drive mechanism, the magnetic heads, and the electronic system contained therein;

FIGURE 27 is a top plan view of the interior of housing, showing the arrangement of the drive mechanism and magnetic head controlling mechanism, and showing the detachable cartridge in position;

FIGURE 28 is a sectional view taken along the line 28—28 of FIGURE 27, showing the arrangement of the output shaft of the motor drive for rotating the shaft of the drive mechanism, and showing the operable positions of the motor "On-Off" switch control lever;

FIGURE 29 is a sectional view taken along the line 29—29 of FIGURE 27, showing the arrangements of the gears that cooperate in the positioning of the magnetic head, and showing the rewind spring mechanism for the central control member located below the housing;

FIGURE 30 is a sectional view taken along the line 30—30 of FIGURE 27, showing arrangements of the driving shaft, the main control member, and the rocker arm for controlling the position of the driving shaft;

FIGURE 31 is a fragmentary top plan view of the driving shaft and the rocker arm, and showing in section the portion of the main control member which determines the position of the rocker arm and the driving shaft;

FIGURE 32 is a fragmentary side elevational view of the rocker arm and the cooperating portion of the main control member;

FIGURE 33 is a fragmentary side elevational view of the portion of the main control member that determines the lateral position of the rocker arm;

FIGURE 34 is a perspective view of the tape-operated levers by which to automatically change the position of the magnetic heads;

FIGURES 35 and 36 are fragmentary top plan views of the main portions of the driving mechanism for the

tape, and showing the actuation of the switch by the main control member for synchronously operating erase heads with the recording and playback head with the direction of movement of the tape, so that pre-recorded sounds are erased immediately preceding the recording of new sounds thereon;

FIGURES 37 and 38 are fragmentary top plan views, partly broken away, of the main portions of the tape-operated head shifting controls, showing an example of one of the levers being engaged by the tape adjacent one end thereof, and carried to a position to effect movement of the heads a predetermined distance transversely of the tapes;

FIGURE 39 is a perspective view of a tape cartridge construction of my invention, showing the central opening through the housing to permit it to be slipped over the magnetic heads so they engage the tape, and showing openings on the top of the housing for permitting the levers to engage the tape;

FIGURE 40 has a sectional view taken along the line 40—40 of FIGURE 39, showing more clearly the interior construction of the cartridge housing;

FIGURE 41 is a sectional view taken along the line 41—41 of FIGURE 40, showing the arrangement for locating and holding the tape-supporting spools in the cartridge housing;

FIGURE 42 is an enlarged, fragmentary sectional view of the slotted end portion of the tape, with the end of a lever in position wherein it is engaged by and carried with the tape;

FIGURE 43 is a top plan view of the tape, with lines indicating diagrammatically the forward and reverse directions of movement of the tape, to aid in explaining the operation of the system of my invention;

FIGURE 44 is a schematic diagram of the circuit for controlling the operation of the erase heads;

FIGURE 45 is a perspective view of another tape cartridge embodying my invention, showing a pair of guide openings in the cartridge casing to receive externally operated capstans;

FIGURE 46 is an exploded view of the parts of the cartridge of FIGURE 45;

FIGURE 47 is a side elevation view of the cartridge, showing the cam surface portions for guiding the capstans into parallel alignment;

FIGURE 48 is a fragmentary sectional view taken along the line 48—48 of FIGURE 47;

FIGURE 49 is a longitudinal sectional view of the cartridge of FIGURE 45, showing a pair of capstans in position to be cammed into parallel alignment by the cartridge as it is fitted onto a housing; and

FIGURE 50 is a view similar to FIGURE 49 in which the cartridge has been moved into place for recording and reproduction, and the capstans are in parallel alignment for driving the tape.

Referring to FIGURE 1, there is shown a recorder housing 10 on which is mounted a plug-in tape cartridge 11. Operation of the recorder is controlled from a hand set 12 which is electrically connected, as at 13, to the housing 10. The hand set 12 is provided with control buttons 14, 15, 16 for use in starting and stopping the capstan, controlling the direction of travel of the tape, and for selectively recording and playing back sounds on the tape. The hand set 12 is provided with a combination microphone and speaker arrangement, which may be of conventional design, for record and playback purposes. Additionally, the hand set 12 houses amplifier means for networks used in conjunction with the recording and playback operations.

Referring to FIGURES 2, 3 and 12—14, the cartridge 11 comprises a casing 20 in which is rotatably mounted a pair of reels 21, 22. Mounted on the reels 21, 22 is a magnetic tape 24 which at its ends is secured to the reels. Rotation of the reels 21, 22 is effected by the tape 24, and to this end the tape 24 is looped or passed around a

5

capstan plug 25 which is rotatably mounted within the casing 20. The shaft 26 of the capstan 25 extends from the casing 20 into the interior of the housing 10, where it is engaged for rotation. Rotation of the capstan 25 in either direction causes the tape 24 to travel around the capstan.

When the cartridge 11 is plugged into the housing 10, an assembly of a record-listen head 30 and a pair of erase heads 31, 32 supported from within the housing are positioned so as to engage the tape 24 (see FIGURE 3). The heads 30-32 are in fixed spaced relation to each other, as by being embedded in a bar 33 of insulating material, as shown. The bar 33 is pivoted at one end, as at 34, to a bracket 35 which is adapted for movement transversely of the tape 24.

With the above described arrangement, I utilize multiple lane recording, whereby with miniature size reels and short length of tape, I obtain an effective recording and playing time comparable to that heretofore obtainable only with large bulky reels and considerable tape footage. This is effected by rotating the capstan 25 in one direction so that the tape passes over the heads 30-32 in one direction, shifting the heads 30-32 transversely of the tape at the end thereof and reversing the rotation of the capstan 25 to cause the tape to pass over the heads in the opposite direction.

With this compact arrangement of reels of the size of spools used for thread, I am able to obtain an effective tape length and playing time comparable to that heretofore obtained with seven-inch reels. This is accomplished, with a tape of given length and width, by the use of heads 30-32 which are sufficiently narrow that they can be shifted incremental distances along the width of the tape, so that the total tape footage passing the heads is equal to the footage heretofore obtainable only with extremely large reels. For example, with a thirty-foot length of tape, which is one inch wide, and heads 30-32 no wider than 0.025 inch, forty parallel tracks are provided; thus, 1200 feet of tape traverse the heads as they are moved from one edge of the tape to the other.

It will be recognized that as the tape 24 transfers from one reel to the other, the reels will be operating at different speeds of rotation. In this embodiment, in order that the tape be maintained in tension at all times, I employ a unique construction and arrangement for rotatably supporting the reels 21, 22, in the manner shown in FIGURES 2 and 12-14.

As shown, the reels are mounted on a non-rotatable U-shaped rod 38, which has threaded ends extending through the inner panel 39 of the casing 20. A pair of nuts 40 are threaded onto the ends of the shaft 38 to abut the panel 39. The reels (see FIGURES 12 and 13) comprise cylindrical elements 41 having radial rims or flanges 42, and are rotatably mounted on the ends of the rod 38 by means of sleeve elements 44. The elements 44 are freely rotatable on the rod.

To prevent the reel from moving along the rod 38, a collar 45 is secured to the rod 38 so as to abut the end of the sleeve 44 remote from the front panel 39. Thus, the reel is located between the collar 45 and the plate 39. To additionally facilitate rotation of a reel, a washer 46 is disposed between the plate 39 and the adjacent end of the sleeve 44.

The means for maintaining the desired tension above-mentioned is a coil spring 47 which encircles the shaft 38 between the reels. The ends 48 of the spring 47 (see FIGURES 12 and 13) are releasably held to the reels, as by being disposed in a longitudinal slot or groove 49 provided in the inner surface of the cylinder 41. To effect the desired tension, all that is necessary is to rotate one reel relative to the other to build up tension in the spring 47. After thus preloading one reel with respect to the other, the reels are located on the plate 39, the threaded ends of the shaft extending through such plate

6

to be secured in place by the nuts 40. In this manner, both of the reels are under tension.

The number of turns or twists of the spring 47 is dependent on the differential effect needed. This in turn is based upon considerations of such factors as the ratio of the total diameter of the cylinder and tape to the diameter of the cylinder 41, the length of the spring 47, and the thickness or diameter of the turns of the spring.

Regardless of the position of the tape, i.e., the relative thicknesses thereof of the two reels, the reels are always under tension. Also, it is by virtue of the tape being on the reels, and of the U-shaped arrangement of the spring 47, that the preloading of the spring will be maintained when the reels are located in place. Thus assembled, as the spring undergoes tension in either direction, it will be distorted on the shaft 38. This is a form of "kinking," but the spring is made sufficiently long so that it cannot undergo a secondary form of twisting or kinking. At dead center, where the tape is of the same thickness on each reel, and the speeds of the reels are momentarily the same, the tension of the spring 47 is at its lowest point; however, there is still sufficient tension in the spring at this mid-point to keep the tape taut.

Another advantage of the tensioning is that the tape is kept taut against the capstan 25. This means that the tape 24 inherently is in frictional engagement with the capstan 25, so that the use of a frictional surface material for the capstan is sufficient to insure movement of the tape as the capstan is turned, i.e., to prevent relative slippage between the tape and the capstan surface.

If desired, additional safeguards may be provided to prevent relative slippage between the tape and the capstan. To this end, a spring-biased pressure roller 50 (See FIGURES 2 and 3) may be employed. As shown, the roller 50 is rotatably mounted on the lower end of a bracket 51, and is biased by a spring 52 so as to be urged against the capstan 25. The roller 50 is provided with a surface covering 53 of resilient material, so as not to mar the tape. The bracket 51 is pivotally mounted at 54, and a stop 55 on the housing 10 is disposed in the path of the upper end of the bracket 51 so as to limit the pressure engagement of the roller surface 53 with the capstan 25.

For effecting rotation of the capstan 25 in either direction, I provide a unidirectional motor 60 (see FIGURE 2) having a short, flexible output shaft 61. The flexible shaft 61 is adapted to drive a rigid shaft element 62, and for this purpose an elongated sleeve or collar 63 is placed over the ends of the shaft elements 61 and 62.

The rigid shaft element 62 is provided with a grooved collar 64 to receive a belt 65. The belt 65 forms a drive connection to a flywheel element 66 (see FIGURES 5 and 6) which is secured to a shaft 67 that is freely rotatable in bearings 68, 69 in a sleeve 70 which extends from a plate 71 on the bottom of the housing 10.

Spaced from the plate 71 is a similar plate 72 (see FIGURES 2 and 5) having a tube 73 in which another shaft 74 is rotatably mounted, such shaft 74 having a flywheel 75 secured thereto.

The flywheels 66, 75 are connected by a flexible shaft 76, the ends of which (see FIGURE 6) are connected to the ends of the shafts 67, 74. With this arrangement, it will be seen that rotation of the shaft 62 by the motor 60 will effect rotation of the flywheels 66, 75, and hence the shafts 67, 74, in opposite directions.

The oppositely rotating shafts 67, 74 are utilized to drive the capstan 25. This is accomplished by means of a drive wheel 78 which is rotatably supported, as on a bracket 79, and which has a shaft 80 for driving the capstan 25. The drive wheel 78 is extremely light in weight, so as to have negligible inertia, and its diameter is many times that of the drive shafts 67, 74. For lightness, the wheel 78 may be made of aluminum or plastic.

To effect the driving connection between the shaft 80

and the end 26 of the capstan 25, the shaft 80 is provided with a split-end sleeve 81 which extends to an opening 82 in the housing 10 which is aligned with the axis of the capstan 25 when the cartridge 11 is in position. The sleeve 81 preferably is formed of spring metal, and the split ends thereof are spaced apart a distance less than the diameter of the shaft 26 extending from the capstan 25, so that the shaft 26 must force the split ends of the sleeve end apart when the cartridge 11 is plugged into position. By this means, the split ends of the sleeve 81 grip the shaft 26, so that turning of the shaft 30 will result in turning of the capstan 25.

Rotation of the drive wheel 78 is effected through the shafts 67, 74. For selectively connecting the shafts 67, 74 for driving the drive wheel 78, the plates 71, 72 are pivotally mounted within the housing 10. Referring to FIGURES 2 and 4-6, the plates 71, 72 are shown to extend upwardly from flat plate elements 85, 86 which are slidably disposed on the bottom or floor of the housing 10, on which they are pivotally mounted at one end, as at 87, 88. The plates 85, 86 are biased toward one another, as by a spring 89 connected between the free ends thereof.

Referring to FIGURE 18 along with FIGURES 2 and 4-6, the plates 85, 86 are provided with confronting projections 90, 91. The projections 90, 91 constitute cam follower elements which facilitate movement of the plates 85, 86 so that one or the other of the shafts 67, 74 engage the drive wheel 88. To this end, a main control shaft 95 extending the width of the housing 10 is provided with a pair of cam elements 96, 97 which are located between the plates 85, 86 the axis of the shaft 95 being parallel to the line between the cam follower projections 90, 91 on such plates.

Referring to FIGURE 10, the cam elements 96, 97 are identically shaped. In the configuration shown, the cam element 97 is of generally cruciform shape having teeth of such size that the space between adjacent teeth is substantially the same distance as the width of the teeth. The cam elements 96, 97 are mounted on the shaft 95 so that the teeth of one are aligned with the space between adjacent teeth of the other. Further, the radial distance from the center of the shaft 95 to the perimeter of the teeth of the cams is greater than the distance between the shaft 95 and the upper surfaces of the plates 85, 86. When any tooth of any cam is located on the line between the projections 90, 91, such line is straddled by adjacent teeth on the other cam. Furthermore, the cams 96, 97 are so spaced that the projections 90, 91 are always in the path of one of the teeth thereof. Accordingly, by virtue of the tension of the spring 89, tending to draw the plates 85, 86 together, rotation of the shaft 95 causes the plates 85, 86 to pivot in parallel.

The distance between the shafts 67, 74 is such that, when a cam element, for example, the cam 97, engages the associated cam follower projection 91 on the plate 86, the plate 86 is moved away from the drive wheel 78, and the other plate 85, due to the action of the spring 89, is moved toward the drive wheel 78. This separates the shaft 74 from the drive wheel 78, and places the shaft 67 in contact with the drive wheel. Opposite movement takes place when the shaft 95 rotates to place the opposite cam 96 in engagement with the associated cam follower projection 90 on the plate 85; the shaft 67 moves out of engagement with the drive wheel 78, and the shaft 74 is moved into engagement with the drive wheel.

Due to the relatively inertia-less character of the drive wheel 78, no slippage occurs upon its being suddenly engaged by one of the shafts 67, 74 to reverse its direction of rotation. Thus, the reversal of the drive wheel is substantially instantaneous, a factor which, as will be seen, insures continuity of recording upon reversal of the tape.

Initially, substantially all of the tape 24 is on one of the reels, e.g., the reel 21. The capstan 25 is rotated in

a direction to feed the tape over the heads 30-32 and onto the other reel 22. When substantially all of the tape is on such other reel 22, the capstan 25 is automatically reversed, and the bracket 35 is simultaneously shifted transversely a distance of one track. When the tape again is on the reel 21, the capstan again reverses to feed it back to the reel 22, and the bracket is again shifted over one track. These operations—reversal of the tape and shifting of the heads 30-32—occur simultaneously, in a manner now to be explained.

Referring to FIGURES 2 and 4, a pinion 100 fixed on the shaft 95 meshes with the teeth on a rack 101 which is supported on the bracket 35. The bracket 35 at its inner end carries a rectangular compartment 102 in which the rack 101 is located. Thus, when the shaft 95 is turned, the pinion 100 turns against the rack 101 to urge it longitudinally. Depending on the direction of such movement, the rack 101 is forced against one end of the compartment 102. The bracket, which is slidable along the base of the housing 10, is thus moved upon rotation of the pinion, thereby shifting heads 30-32 transversely of the tape 24.

Guide means are provided for the bracket 34, in the form of a pair of pins 104 (see FIGURE 2) on either side thereof, a slot or keyway 105, and a pin 106 (see FIGURE 4) on the bottom of the bracket which is slidable in the slot 105. Upon the bracket 35 being moved by the action of the pinion 100, it slides between the pins 104. The pins 104 and the pin 106 and slot 105 cooperate to prevent lateral movement of the bracket.

The rack and pinion arrangement in this embodiment employs unique anti-backlash means. Referring to FIGURE 4, the rack 101 rests on a cushion 107 in the compartment 102. The cushion 107 is made of resilient material (e.g., foam rubber), against which the rack 101 is urged by the pinion 100. The rack 101 is free to move or rock longitudinally in the compartment 102. When the pinion forces the rack longitudinally, the constant upward pressure exerted by the cushion 107 prevents "play" between the rack and pinion elements.

To effect operation of the pinion 100 for moving the bracket 35 and the heads 30-32 transversely a distance of one track or lane, the shaft 95 is rotated by a mechanism which includes a ratchet wheel 108 secured thereto (see FIGURES 2 and 15) and a pawl assembly 109 operated by a solenoid 110 (see FIGURES 2 and 4).

The pawl assembly 109 includes a vertical plate 111 (FIGURE 15) which is pivotally connected at one end to a spring-biased plunger 112 of the solenoid 110. The plate 111 is disposed on one side of the ratchet wheel 108, and has an elongated slot 113 to receive the shaft 95 and to permit its movement transversely of the shaft. Above and below the ratchet wheel 108, the plate 111 has a pair of horizontal legs 114, 115 (see FIGURE 4) which are curved at their inner ends (FIGURE 15) toward the ratchet wheel, as at 116, 117. A pair of springs 118, 119 are connected between the upper corners of the plate 111 and the adjacent end of the housing 10.

The plate 111 is positioned so that when the solenoid 110 is actuated, one of the curved ends 116, 117, which constitute pawls, will engage the ratchet wheel 108, to thereby force the shaft 95 and pinion 100 to rotate and move bracket 35 longitudinally. The positioning of the plate is effected through a lever 120 which is pivoted on the side of the housing 10, as at 121, and from which a finger 122 extends through the slot 113. The lever 120 has two positions—a forward position, in which the finger 122 holds the plate in an upper position where the lower pawl 117 is against the ratchet wheel 108, and a rearward position, in which the finger 122 holds the plate down so the upper pawl 116 is against the ratchet wheel.

The plunger 112 normally is in an outer position. When the solenoid 110 is energized, the plunger 112 and plate 111 are moved longitudinally, and the operative pawl

thereby forces the ratchet wheel 108 and the shaft 95 to turn. It should be noted (see FIGURE 15) that both sides of the teeth of the ratchet wheel 108 are substantially radial, whereby the ratchet wheel can be moved readily clockwise or counterclockwise by the pawls 116, 117.

My invention effects energization of the solenoid 110 automatically at the end of each recording track. To this end, a D-C source 124 (see FIGURE 20), which may be provided by batteries 125 as illustrated in FIGURE 4, is utilized to energize the solenoid 110. The solenoid is connected between the D-C source 124 and a leaf spring contact element 126 (see FIGURES 3, 16, and 17 along with FIGURE 20).

The contact element 126 is secured at one end to the housing 10, as shown at 127, and at its other end is urged against the capstan 25. Such movable end of the contact 126 normally is separated from the capstan 25 by the tape 24. However, the tape adjacent its ends is partially cut away on one side, as indicated at 128, with which the contact 126 is aligned. When such portions 128 appear at the capstan 25, the contact 126 is free to move inwardly and engage the capstan 25.

The portion of the capstan 25 engaged by the contact 126 is metallic, as indicated at 129. This forms a ground connection to the housing through the capstan 25, the drive shaft 80 and bracket 79. This completes the connection of the solenoid across the source 124, whereupon the solenoid 110 is energized to effect movement of the bracket 35 and the heads 30-32 as previously described. As shown in FIGURE 16, the remainder of the capstan 25 between its ends is covered by a sleeve 130 which frictionally engages the tape and minimizes slippage between the tape and the capstan in the manner previously indicated.

Recording on all the available tracks is effected by setting the bracket 35 so that the heads 30-32 are positioned at one edge of the tape 24, e.g., the outer edge as shown in FIGURE 2. Thereafter, the bracket is shifted, one track at a time on each reversal of the capstan 25, until they reach the opposite edge of the tape. Further, the erase heads 31, 32 are selectively operated in accordance with the direction of travel of the tape. Referring to FIGURES 3 and 20, when the tape 24 is traveling from left to right, the erase head 31 which is ahead of the record head is adapted to clear the tape. When the tape is traveling from right to left, erase current is supplied to the erase head 32 ahead of the record head 30.

The electronic networks for recording and listening are shown in FIGURE 20. These include a pre-amplifier 132, a record amplifier 133, a playback amplifier 134, and an erase current source 135. The erase current source 135 may be either a D-C source, in which case it is located in the housing 10 (and may constitute the batteries 125), or an A-C source such as an oscillator, which is located in the hand set 12 along with the amplifiers 132, 133 and 134. The circuits employed are conventional, and are preferably composed of miniature components, such as are effected with transistor devices, so they are readily incorporated in a hand set of reasonable size.

The input of the pre-amplifier 132, the outputs of the record and playback amplifiers 133, 134, and the output of the erase current source 135 are connected to the switch arms of respective single-pole, double-throw switches 136, 137, 138, 139, which are ganged as indicated at 140. The switch 136 in one position connects the input of the pre-amplifier 132 to the microphone 141, and in the other position connects such input to the record-listen head 30, through connections 142 and 143. The switches 137, 138, 139 each have one dead position. In their other positions, the switch 137 connects the output of the record amplifier 133 to the record-listen head 30, through connections 144, 143, the switch 138 connects the output of the playback amplifier 134 to the loudspeaker 146, and the switch 139 connects the erase current source 135 to the erase heads 31, 32 (in a manner to be described more fully hereinafter).

The switches 136-139 are so arranged that the record amplifier 133 and the erase current source 135 are connected to the record-listen head 30 and the erase heads 31, 32 when the pre-amplifier input is connected to the microphone 141, in which case the switch 138 is in its dead position. When the switches are moved to connect the playback amplifier 134 to the loudspeaker 146, the switches 137, 139 are connected to their dead positions, and the switch 136 connects the input of the pre-amplifier 132 to the record-listen head. Respective connections 147, 148 are provided between the pre-amplifier 132 and the record and playback amplifiers 133, 134 to effect recording or playback of sounds in accordance with the switching.

To supply erase current to the erase head which is ahead of the record-listen head, I utilize a switch assembly mounted on the shaft 95. Referring to FIGURES 2, 4, 7, 8, 20, and 21, such switch assembly comprises a pair of conductive elements 149, 150 separated by a disc 151 of insulating material (FIGURES 7 and 8). The conductive elements 149, 150 are secured to the insulating disc 151 in such a way as to be insulated from each other, e.g., as by bolts 152 extending through each element into the disc 151, the bolts in one element being non-aligned with those in the other. The disc 151 is secured to the shaft 95, but the elements 149, 150 do not touch the shaft, by virtue of central openings 154, 155 therein which are of greater diameter than the shaft.

A leaf spring contact element 156, the width of which is greater than the thickness of the insulating disc 151, is secured to the housing (see FIGURES 2 and 7), as at 157, with the free end thereof spanning the disc 151. The elements 149, 150 are shaped and oriented so that the contact 156 engages them alternately as the shaft 95 rotates.

The contact 156 (see FIGURES 20 and 21) is connected, as at 158, to the switch 139, and the respective conductive elements 149, 150 are engaged by brush contacts 160, 161 which are connected to the erase heads 32, 31 through respective connections 162, 163. Thus, rotation of the shaft 95 to alternately connect the elements 149, 150 to the contact 156 results in the erase heads 31, 32 being alternately connected to the erase current source 135.

The elements 149, 150 rotate in unison, so that each time the shaft 95 is turned by the solenoid 110 to shift the positions of the heads 30-32 and the direction of rotation of the capstan is reversed, the erase current source 135 is disconnected from one erase head and conductively connected to the other. The elements 149, 150 are positioned so that, as the tape 24 moves from left to right, the contact 156 is in engagement with the element 150, and as the tape moves from right to left, the contact 156 is in engagement with the element 149. Thus, in the recording phase, the tape 24 is always erased before it passes over the record-listen head 30.

A master "on-off" switch 165 is provided for supplying power from the source 124. When the switch 165 is closed, the motor 60 operates continuously. However, I provide means for selectively coupling and decoupling the drive wheel 78 at any time from the one of the shafts 67, 74 which is driving it. Referring to FIGURES 2, 18, and 19, this starting and stopping of the drive wheel 78, and hence the capstan 25, is effected through a solenoid 166 having a spring-biased plunger 167 located adjacent the bottom of the housing 10.

The plunger 167 extends through a flat plate 168 which is disposed between the plates 85, 86. When the solenoid 166 is energized, the plate 168 is pulled by the plunger 167. The plate 168 is shaped so as to spread or cam the plates 85, 86 apart sufficiently so that neither of the shafts 67, 74 is in engagement with the drive wheel 78. The next time the solenoid 166 is energized and the plunger 167 is pulled back, the plate 168 releases the plates 85, 86 to permit the spring 89 to urge them together to as-

sume the positions they occupied previously. Since the shaft 95 has not moved, the cams 96, 97 are in the same positions, so that this result will obtain automatically.

Referring to FIGURE 20, this coupling and decoupling of the drive wheel 78 is controlled by the "start-stop" switch 14, which is connected from the handset 12 (FIGURE 1) to the source 124 and the solenoid 166, as indicated at 170, 171.

Again referring to FIGURES 2, 18 and 19, the arrangement illustrated for forcing the plates 85, 86 apart includes lateral cam follower projections 172, 173 on the plates 85, 86. The plate 168 constitutes a cam having lateral projections 174, 175 which are adapted to engage the projections 172, 173 when it is actuated by the solenoid 166.

To hold the cam plate 168 in the position where it forces the plates 85, 86 apart, on one closure of the switch 14, and to release it on the next closure of the switch 14, there is provided a ratchet, cam and detent mechanism in the form of a cup element 176 having spaced notches or cut-out portions 177 along the skirt thereof. A pawl or detent element 178 is pivoted intermediate its ends and is biased at one end, as by a spring 179, to ride against the rim of the cup 176. Upon rotation of the cup, the spring-biased end of the detent 178 acts as a cam follower, following the contour of the rim. The detent 178 is bent, as shown, so that its other end rocks up and down.

The cam plate 168 is provided with a notch 180. When the cam plate 168 is retracted to decouple the drive to the drive wheel 78, the spring-biased end of the detent 178 is arranged to enter a notch 177 in the cup 176, and its other end enters the notch 180 of the cam plate 168. The cam plate is thus locked in the retracted position. On the next succeeding closure of the switch 14, the cup 176 is rotated to force the detent 178 out of the notch 180 and free the cam plate for return to its normal position for permitting the drive wheel 78 to be driven.

To effect rotation of the cup 176, ratchet wheel 181 is secured to the upper surface thereof. The plunger 167 is provided with an L-shaped arm 182 on which is mounted a pawl 183. Whenever the plunger 167 is retracted, the pawl 183 engages a tooth of the ratchet wheel to rotate the cup 176. The cup 176 is held against reverse rotation by a detent finger 184 which is pivotally mounted on the housing 10, as at 185. The finger 184 is biased, as by a leaf spring 186, so that it is always urged against the ratchet wheel 181.

In addition to the "start-stop" and record-listen controls previously described, my invention also incorporates a unique high-speed drive. Referring to FIGURES 2 and 4, there is provided a high speed motor 187 having a flexible output shaft 188 on which is secured a sleeve 189. The sleeve 189 extends through the upper end of a vertical arm 190 which extends from a cam follower plate 191 pivotally supported, as at 192, on the base of the housing 10. A spring 193 extends between the arm 190 to an arm 194 that is fixed at its lower end to the base of the housing. The spring 193 is in tension, so as to constantly urge the movable arm 190 toward the fixed arm 194.

On the end of the sleeve 189 is an enlarged drive head 195, preferably having a frictional surface, which is located adjacent the periphery of the drive wheel 78. The cam follower plate 191 has a projection 196 which normally abuts a projection 197 on the cam plate 168. When the cam plate 168 is retracted, the projection 197 moves past the projection 196, whereupon the plate 191 is freed to move under the action of the spring 193. Such movement of the plate 191 places the drive head 196 in engagement with the periphery of the drive wheel. Thus, the high-speed motor shaft is connected to the drive wheel 78 simultaneously with the separation of the shafts 67, 74 therefrom.

Upon release of the cam plate 168 to return to its nor-

mal position under the action of the plunger 167, the projection 197 is forced back to its normal position, thereby to move the plate 191 and separate the drive head 195 from the drive wheel.

Thus, any time the "start-stop" switch 14 is actuated to disconnect the shafts 67, 74 from the drive wheel, i.e., to stop recording or playback, the drive wheel is set up for high speed operation. Referring to FIGURE 1 and 20, operation of the high speed motor 187 is effected through the switch button 16, which controls a double-pole, double-throw switch having switch arms 200, 201 movable from a neutral position to positions "F" and "R" for controlling the direction of movement of the tape and the heads 30-32. The switch button 16 may be of sliding latch type, capable of remaining in the "F" or "R" position to which it is moved. Movement of the switch button 16 in one direction connects the switch arms to the "F" contacts 202, 203; sliding the push button in the opposite direction connects the switch arms to the "R" contacts 204, 205.

The switch cams 200, 201 are connected to the brushes of the motor 187, as at 206, 207. The "F" contact 202 and "R" contact 205 are directly connected, as at 208, and the remaining "F" contact 203 and "R" contact 204 are directly connected, as at 209. These switch connections are operable to effect successive movements of the heads 30-32 in one direction along the tape 24 when the switch arms 200, 201 are in the "R" positions, and in the opposite directions when they are in the "F" positions. How this is accomplished will now be explained.

The "F" contacts are connected, as at 210, 211 (FIGURE 20), to respective leaf spring contact elements 212, 213. The contact elements 212, 213 engage a switching device secured to the shaft 95 which comprises conductive elements 214, 215 (FIGURE 9) separated by an insulating disc 216, such conductive elements 214, 215 being arranged and shaped as the conductive elements 149, 150 previously described for connecting the erase heads 31, 32 to the erase current source 135.

The contact elements 212, 213 are both wider than the insulating disc 216. The conductive elements 214, 215 each have equally spaced notches along their peripheries, and are arranged so that the notches are staggered. The contact elements 212, 213 are connected to the housing 10, as at 218, 219, with the end of one element 212 extending beyond the end of the other. Thus arranged, the ends of the contact elements 212, 213 engage a respective one of the conductive elements 214, 215.

Accordingly, when the shaft 95 is rotated, each of the contact elements 212, 213 alternately engages the conductive elements 214, 215, but the conductive elements are engaged by only one of the contact elements 212, 213 in any position of the shaft 95.

The conductive elements 214, 215 are connected to the D-C source 124, as by respective brush contacts 220, 221 to ground, and through a connection 222 to the main "on-off" control switch. When the switch is closed, and with the switch button 16 in the "F" or "R" position, motor 187 is driven in one direction in one position of the shaft 95, and in the opposite direction in the next succeeding position of the shaft 95.

The pawl plate 111 must be properly positioned so that the high speed motor 187 will effect successive movements of the shaft 95, and hence the heads 30-32, in the proper direction. When the switch button 16 is in the "F" position, which characterizes movement of the heads 30-32 from the outer to the inner edge of the tape 24, the lever 121 is in the position to permit the lower pawl 117 to engage the pinion 108. Successive movements of the plunger 112 by the solenoid 110 thus effect clockwise rotation of the shaft 95 (viewed in FIGURE 15) to move the bracket 35 and the heads 30-32 in the same direction.

When the switch button 16 is in the "R" position, the lever 121 is moved to place the upper pawl 116 in position to actuate the pinion counterclockwise and effect suc-

cessive movements of the heads 30-32 from the inner edge to the outer edge of the tape. Thus, by synchronizing the setting of the pawl plate 111 with the position of the switch button 16, the high speed motor is adapted to rapidly move the tape in either direction to any desired position.

The manual control for positioning the pawl plate 111 is illustrative only. Preferably, the position of this plate is effected automatically on movement of the switch button to either of the "F" or "R" positions. One means for such automatic positioning is illustrated in FIGURE 20, and includes a relay 225 for actuating a lever 121' connected to the plate 111. The lever 121' is adapted by a spring 226 to normally hold the plate 111 in a position wherein the lower pawl 117 will engage the pinion 108 when the solenoid 110 is energized to retract the plate 111. When the relay 225 is energized, the lever 121' is pivoted to a position where the pawl 116 will engage the pinion 108 when the plate 111 is retracted.

Thus, when the switch button 16 is in the "F" position, the pawl 117 for effecting "forward" movement of the heads 30-32 is in its normal position. When the relay 225 is energized, the pawl 116 is held in position for effecting "reverse" movement of the heads. To effect such positioning for reverse movement automatically, I utilize a switch having its switch arm 227 ganged with the switch arms 200, 201 of the F-R switch. The switch arm 227 is connected to the relay 225, as at 228, and is adapted, when the switch button 16 is moved to the "R" position, to connect the relay coil to ground, as through a connection 229; the other end of the relay coil is connected, as at 230, to the "on-off" switch. In the other positions of the switch button 16, i.e., neutral and "F," the switch arm 227 is disconnected from the ground.

From the foregoing, it will be readily apparent that my invention embraces other mechanical and electro-mechanical means for properly positioning the pawls 116, 117 for actuating the pinion in the proper direction when the switch button 16 is placed in the "F" and "R" positions.

The above-described control for the high speed motor 187 is useful for quickly and positively moving the tape 24 so that the heads 30-32 are located on any desired track. If, for example, one is dictating and desires to play back material recorded on a track preceding that on which sound is presently being recorded, all he needs to do is move the switch button 16 to the "R" position. Thereupon the high speed motor 187 reverses the capstan drive and the heads 30-32 are shifted in the direction opposite to that in which they were moved while recording. The track is reached quickly in this manner, whereupon movement of the record-listen control switch to the play-back position permits the desired material to be reproduced.

My invention also incorporates additional means for quickly positioning the heads 30-32 on any desired track and for operating the capstan to place a specific portion of the tape on which track against the heads. To this end, an external positioning knob 231 is secured on one end of the shaft 95 (see FIGURES 1-3). The knob 231 carries spaced members corresponding to the number of tracks for the heads 30-32. The knob 231 is used to turn the shaft 95 independently of the solenoid 110.

The housing 10 carries an index mark 232, and the alignment of any number on the knob 231 indicates the track with which the heads 30-32 are aligned. Thus, to place the heads 30-32 on any desired track, all that is necessary is to turn the knob 231 to align the number representing such track with the index 232.

This selection can be made at any time and from any track position. For example, recording may have proceeded to the point where the heads 30-32 are on the tenth track, in which case the knob 231 will have rotated with the shaft 95 to a position where the numeral "10" is aligned with the index 232. If it is desired to move the

heads back to the second track, the knob 231 is turned to align the numeral "2" with the index 232.

To identify the portion of the track which lies on the heads 30-32, the tape 24 is suitably numbered, and the cartridge casing 20 has view windows 234, 235 through which the numbers are visible. Each half of the tape is numbered (see FIGURE 22) so as to provide consecutively reading numbers regardless of the direction (right-to-left or left-to-right) in which the tape is moving. For example, a tape having an available recording length of thirty feet may have numbers 0-1000 (approximately each 1/3-inch apart) reading from left to right on one-half of the tape, and the same numbers reading from right to left on the other half. The numbers may be placed on either surface of the tape, although if placed on the oxide surface, they would preferably be defined by oxide material which is of a color contrasting with the remaining oxide coating. Preferably, however, the numbers are imprinted on the nonsensitive or shiny surface, in which case the numbering can be done for relatively little expense.

The significance of numbering the tape as above explained will be seen upon noting that the direction of tape travel is related to the track on which the heads 30-32 are located, in terms of whether the track is an even-numbered track. For example, assume that the heads are initially positioned at the outside edge of the tape, so that they are moved toward the inner edge is recording proceeds, i.e., the outside track is track "I." Also, assume that the tape is initially on the left-hand reel 21. The shiny or numbered side of the tape is visible through the windows 234, 235.

In the above-assumed condition, the start of the record cycle results in the capstan 25 moving the tape from left to right, with the sensitive surface passing over the heads 30-32. The numbers visible in the window 234 (see FIGURE 23), which read from right to left on the tape, are the numbers which appear in an increasing progression as they pass the windows 234 from left to right. The only time such numbers appear as an increasing progression is when the tape is traveling from left to right, i.e., transferring from the left reel 21 to the right reel 22. This event occurs only on the odd-numbered tracks "1," "3," "5," "7," "9," "11."

On the even-numbered tracks "2," "4," "6," "8," "10," "12," the tape travels from right to left. The numbers on the outer half of the tape, appearing in the window 235, appear in an increasing progression.

Thus, for "forward" movement of the tape, wherein the heads 30-32 are moved from the outer to the inner edges of the tape, the numbers in the windows 234, 235 which appear as increasing numbers are correlated with the tracks on which the heads 30-32 are located. Conversely, if the capstan 25 is reversed from its normal direction of rotation, as by moving the switch button 16 to the "R" or "F" position to operate the high speed motor 187, the numbers in the window identified with the track will appear as decreasing numbers.

From the foregoing, it will readily be seen that one can position the heads on any desired track, and then operate the motor 187 to quickly move the tape to a position wherein the heads 30-32 are located at a specifically identifiable portions thereof. Preferably, the windows 234, 235 are covered with magnifying lens elements, to insure that the numbers are readily observable when the inner end of the tape on the reel 21 is approached, i.e., when substantially all of the tape has been transferred to the right-hand reel 22.

My invention not only provides a unique dictating machine for office use, but is uniquely adapted to the recording of music. For example, by providing a tape length sufficient to record an entire piece on one track, e.g., 2.5 minutes playing time for popular songs and music, a cartridge is provided which contains a plurality of songs, one on each track. For example, a tape having twenty

tracks contains twenty recorded songs. The total volume of such a cartridge is less than ten cubic inches, which is in sharp contrast to a stack of ten 7-inch disc records (each having one song recorded on each side), which occupy a total volume between 30 and 40 cubic inches.

Furthermore, the problems involved in handling conventional disc records, as by placing them on the turntable for playing a song on one side, then turning them over to play the song on the other side, and also the attendant risk of damage to the playing surfaces, are all non-existent in my invention. After the tape is initially assembled in the cartridge, there is no further handling of it in recording or reproducing. A label provided on the cartridge lists the tracks by number and the titles of the pieces recorded on the respective tracks. On plugging the cartridge into place, the selection of a desired number is simply made by turning the knob 231 to align the desired track number with the index 232. Then the record-listen switch is placed in the "listen" position, and the start-stop switch 14 is actuated to start the tape. At any time, of course, the start-stop switch 14 may be actuated to decouple the capstan drive connection.

On the other hand, if it is desired to play all of the numbers, this will automatically be accomplished by setting the knob 231 on "track 1." Actuating the start-stop switch 14 to start the capstan turning effects playback of all pieces on the tracks in succession.

The foregoing described feature for track selection makes possible the provision of "juke box" music constructions of amazingly small size. For example, a tape 24 several inches wide (e.g., 5 inches) may be employed, on which are recorded one hundred songs, one to a track. A control knob 231' (see FIGURE 25) having members 1-100 thereon is releasably held by control means 240 which is adapted to release the knob 231' for rotation upon inserting a coin therein, as through a coin slot 241. The numbers on the knob 231 identify tracks on which specific pieces shown on an accompanying label (not shown) are recorded. The desired selection is made by aligning the proper track number with the index 232'.

For a wide tape, I prefer to use a sprocket drive. To this end, and referring to FIGURE 23, a capstan 25' having sprocket teeth at its ends is employed, and the tape 24' is provided with sprocket holes at its edges. Such a drive is conventional of course. With such a sprocket drive, I provide a narrow slot 128' in the edge of the tape adjacent each end, so that the metal portion 129 of the capstan 25' will be exposed for engagement by the contact 126 to effect reversal of the capstan drive.

Since the coin-operated control means 240 is used for reproduction only, only a loudspeaker is needed, i.e., the record amplifier and microphone are eliminated, and the device is always connected to effect reproduction. Also, the erase heads 31, 32 and erase current source 135 are eliminated.

The control means 240 also controls the starting and stopping of the normal tape drive, and for this purpose may include a conventional timing mechanism (not shown) to maintain such condition of operation for the allowable playing time, e.g., the time for the entire length of tape to pass over the head 30 on the selected track, and to stop the operation at the end of such period.

It may be necessary to delay normal tape drive and reproduction where a selection requires that the tape first be transferred from one reel to the other. For example, the tape may be located on the left-hand reel 21, as for movement from left to right for reproducing songs on an odd-numbered track. If one elects to play a number recorded on an even-numbered track, it is necessary first to transfer the tape to the right-hand reel 22 before playing begins. The operation of the high speed motor 187 and the starting of the reproduction must be synchronized so that the motor 187 is first operated to quickly transfer the tape to the right-hand reel, and then the start-stop

switching mechanism is actuated to effect reproduction of the selected recording.

Similarly, if material on an odd-numbered track has been previously reproduced, so that the tape at the end of such reproduction is located on the right-hand reel 22, the subsequent selection of an odd-numbered track requires that the tape first be transferred to the left-hand reel 21.

The last setting of the knob 231' provides the necessary indication of whether the tape must be transferred. Suitable instructions on the operation of the device disclose to one making a new selection that if an odd-numbered track number is aligned with the index, any number selected on an even-numbered track will automatically be played on inserting a coin in the slot 241; but if a number on another odd-numbered track is to be selected, the reverse control switch 16 will first have to be actuated for transferring the tape back to the left-hand reel 21. Similarly, if the last piece played is indicated by the knob 231' as having been an even-numbered track, and another even-numbered track is being selected, the reverse control switch 16 must first be actuated for transferring the tape onto the right-hand reel before reproduction will start. Ganging of the start-stop and reverse control switches 14, 16 aids in preventing operation of the capstan from the normal drive motor 60 until the tape has been transferred.

It will be seen that the transfer of tape when necessary may be effected automatically, and that my invention embraces the use of such cooperative control means.

If desired, recording on each track may be started in every case with the tape on one reel, e.g., the left-hand reel 21. The reproduction will thus require, in every instance, transfer of the tape back from the right-hand reel 22 to the left-hand reel 21. To accomplish this automatically, the solenoid 110 is adapted to actuate the reverse switch 16 at the end of each track; in this case, only the end of the tape secured to the left-hand reel 21 is adapted to expose the metal portion of the capstan for actuating the solenoid. A suitable timing mechanism (not shown) for the motor 187 automatically stops it when transfer of the tape to the left-hand reel 21 is completed. Thus, for each selection, the unit is always conditioned for reproduction upon inserting a coin.

The above described reproducer will be seen to be extremely simple and compact, in sharp contrast to the elaborate and expensive automatic controls and bulky, heavy apparatus required for selecting and manipulating disc records for reproduction in conventional "juke boxes."

Other features of my invention reside in details of construction and arrangement of the parts thereof. One such feature resides in a simple locking lever 250 (FIGURES 1 and 3) on the housing 10 for releasably securing the cartridge 11 in place when it is plugged in. The lever 250 is pivoted on the housing, as at 251, and has a finger 252 on its inner end which is received in an opening 253 in the cartridge casing 20. When the cartridge is located on the housing, the lever 250 is moved to a position when the finger 252 locks against the inner surface of the panel 39, thereby to hold the cartridge firmly in position.

Another feature is the provision of parallel rods 255, 256, 257 (see FIGURE 3) extending the width of the tape along the bottom of the cartridge 11. As shown, the rods are located in aligned notches in the front and rear panels of the cartridge, with the axis of the center rod 256 being slightly lower than the axes of the other rods 255, 257. These rods are so spaced that the erase heads 31, 32 bear against the tape 24 with equal pressure. The heads 30-32 are disposed along an arc, as will be seen by inspection of FIGURE 3. The left-hand erase head 31 is positioned between the capstan 25 and the left rod 255; the record-listen head 30 is located be-

tween the rods 255, 256; and the erase head 32 is located between the rods 256, 257.

As seen, the heads when positioned in engagement with the tape force the tape inwardly slightly. Since the tape is under tension at all times, this arrangement insures that the tape is always biased against the heads, thus providing the necessary firm sliding engagement, as for maximum effectiveness of the head 30 in recording and playback operations, and of the erase heads in effectively demagnetizing the tape ahead of the recording.

The heads 30-32 are held in position by means of a latch member 258 on the housing which engages the bar 33 in which the heads are embedded. When it is desired to remove the cartridge, the latch 258 is moved to permit the bar 33 to be pivoted away from the tape. Release of the cartridge from the housing, by movement of the lever 250 out of locking engagement therewith, permits its removal without dragging the tape along the heads.

It is, of course, not desirable, to record in any other situation than where the switches 136-138 are in the record position. In addition to the described disengagement of the erase current source 135 during reproduction, I also provide interlock means for preventing recording and/or erasing during operation of the high-speed motor 187. Referring to FIGURE 20, this safety feature is provided by switches located in the leads 143, 162, 163, wherein the switch arms 260, 261, 262 are ganged with the switch arms 200, 201, 227. The switch arms 260-262 are adapted in only the neutral positions of the switch arms 200, 201, 227 to connect the respective heads 30, 31, 32 to the heads 143, 163, 162.

I also provide positive positioning means for locating the heads 30-32 in the center of the tracks to which they are moved by the action of the shaft 95. The locating means (see FIGURE 11) comprises a star wheel 265 secured to the shaft 95, and a detent arm 266 which is pivotally mounted on the housing 10, as indicated at 267. The arm 266 at its lower end is connected to a spring 268, which constantly urges the upper end of the arm toward the star wheel 265. The upper end of the arm carries a pin 269 which engages the star wheel 265.

The periphery of the wheel 265 is formed of spaced teeth, the sides of which meet to form slightly curved troughs 270. With this construction, the pin 269 is forced by the spring 268 to the center of the trough 270 between adjacent teeth. This position of the pin corresponds to the center of a track, and the spring 268 exerts enough force so that, if the shaft 95 were to be turned, as by operating the knob 231 or solenoid 110, only to a position wherein the pin 269 was positioned on the side of one of the teeth, the force of the pin causes the shaft 95 to rotate further until the pin is centered between the teeth. However, the shaft 95 readily turns against the pin when actuated by the solenoid 110 or knob 231. When this happens, the pin rides along and over the teeth of the wheel 265. But when direct operation on the shaft 95 ceases, the detent 266 and spring 268 cooperate to insure that the shaft will be held in a position where the heads 30-32 are centered on a track.

For manual start-stop control, I provide an externally operable pull bar 272 (see (FIGURES 1, 2 and 18) which is secured at its inner end to the plate 168. The outer end of the bar 272 rides in a slot 273 (see FIGURE 1) which at its rear end curves downwardly and forwardly. To move the plate 168 to the "stop" position, where the motor 187 is brought into driving connection with the drive wheel 78, the bar 272 is pulled rearwardly so that the end thereof moves into the forwardly inclined portion of the slot 273. The end of the bar 272 is thus latched, thereby to hold the plate 168 in the retracted position. Unlatching is effected by simply moving the end of the bar 272 upwardly to the horizontal portion of the slot 273, whereupon the plate 168 and bar 272 are moved

to the normal forward position by the action of the spring-biased plunger 167.

By virtue of my moving the tape at a constant speed (determined by the speed of rotation of the capstan) and the frictional engagement between the capstan and the tape, there is no problem of slippage between the capstan and tape during high speed operation. Furthermore, there is no problem of slippage or of continued movement of the tape upon stopping the high speed motor. Immediately upon stopping the motor, the capstan (and hence the tape) comes to rest. It is this feature which makes it possible to rapidly and accurately position any portion of a track adjacent the heads.

For high speed forward or reverse movement, transfer of the tape from one reel in my compact cartridge takes place much faster than is possible with prior art apparatus. For example, a 30-foot length of tape can be transferred in a matter of twenty seconds or less, which of course is at a much lower capstan speed than would be possible or practical in prior art mechanisms.

The normal tape speed, for recording and playback, may be any of the conventional speeds, i.e., 1½ inches per second, 3¾ inches per second, 7½ inches per second, or any other speed practical for recording particular types of sounds. Further, it will be appreciated that my invention embraces means for selectively operating the drive wheel so that the capstan will move the tape at any of the desired speeds.

It should be noted that the same arrangement of the cams 96, 97 for controlling the drive connection to the drive wheel 78 upon each shift of the heads 30-32, and the same rack 101 and pinion 100, can control such connections and shifting in synchronism regardless of the number of positions the heads can be placed in. For a particular configuration of the cams 96, 97, and number and spacing of teeth on the rack and pinion, the number of positions to which the rack (and hence the heads 30-32) can be shifted is determined. To use these same elements where a greater number of positions of the heads is desired, all that is necessary is to employ a reducing gear, not shown) between the pinion 100 and the rack 101.

Referring to FIGURE 26, there is shown a housing 310 that includes a motor casing 311 mounted on a support base 312, and an elongated cover element 313 hinged to the motor casing 311, as at 314. The cover element 313 encloses a driving mechanism, tape supporting mechanism, and magnetic heads which are supported on the base 312. For operating the drive mechanism and effecting recording and reproducing operations, a record-listen control lever 318 is provided that extends through a slot 319 in the cover 313. The housing 310 includes a portion 320 that houses suitable microphone and loudspeaker elements, together with electronic control means by which to provide the requisite power for recording sounds on tape or reproducing sounds recorded on the tape. A mesh screen 321 is provided in the housing portion 320 through which sounds pass to actuate the microphone and from which sounds emanate from the speaker. The entire unit can be fitted into a man's coat pocket. Yet, despite such small size, the unit has as much (or more) playing time as can be obtained with conventional recorders using 7-inch diameter reels for carrying 1,200 feet of magnetic tape.

Other controls accessible from the exterior of the cover element 313 include a lever 325 extending through a slot 326 for controlling the direction of movement of the magnetic tape. Also, to indicate visually the line along the tape at which the magnetic heads are positioned, the cover element 313 is provided with an opening 327 through which to view a fixed index 328 and the peripheral portion of an angularly movable disc 329. The disc 329 is provided with spaced numbers adjacent its periphery, and is arranged so that the number thereon aligned

with the index 328 corresponds to the position of the magnetic heads along the tape.

As will be described hereinafter, the shifting of the magnetic heads during recording and playback is automatic. However, I provide two controls by which to manually change the position of the magnetic heads along the tape. One such control includes a lever 330 extending through a slot 331 in the cover element 313, and a rotatable knurled knob 332 extending through an opening 333 in the cover element. The lever 330 is utilized as a separate control for stepping the magnetic heads in one direction along the tape, and the control knob 332 is utilized to move the magnetic heads in the opposite direction along the tape.

The supporting means for the magnetic heads is shown in FIGURES 27 and 30. Referring to FIGURES 27 and 30, three spaced heads 340, 341, 342, are mounted in a support block 343 for sliding movement adjacent the free end of the cover element 313. The block 343, as shown, is positioned in a guide channel 344, with the sides of the block 343 slidably engaging the walls of the channel 344, and the bottom of the block 343 rests on ledges 345 that extend from the side walls of the channel 344.

The block 343 adjacent its upper end is secured to one end of a rack 347, which is a rod provided with vertical teeth along a substantial portion of its length. The rack 347 forms part of a rack and pinion mechanism, the pinion being shown at 348 (FIGURES 27 and 29) mounted on a shaft 349 that is journaled at its lower end in the base 312. The rack 347 is supported so as to move only longitudinally, under the action of the pinion 348.

Movement of the rack 347, and hence the block 343 and the magnetic heads 340-342, is effected through a shaft 351 on which the knurled control knob 332 is mounted. As shown in FIGURE 29, the lower end of the shaft 351 is journaled in the base 312, and extends into a cylindrical cup 352 that is mounted on the lower surface of the base 312, and which has a flat cover element 353. Positioned within the cup 352 is a coil spring 354 which, at its inner end, is secured to the shaft 351, and at its outer end engages the inner wall of the cup 352. With this arrangement, the shaft 351, through the control knob 332, is rotatable in one direction to tighten the spring 354, whereupon the shaft 351 is biased by the spring 354 for rotation in the opposite direction.

Mounted on the shaft 351 is a small gear 356 which is in meshing engagement with a larger gear 357 that is fixed on the shaft 349 on which the pinion 348 is mounted. Thus, as indicated in FIGURE 27, rotation of the control knob to turn the gear 356 counterclockwise causes the gear 357 and the pinion 348 to rotate in the clockwise direction, whereby the rack 347 is moved to the left. The ends of the channel 344 are shaped to limit the travel of the block 343 in either direction. In both the extreme right- and left-hand positions of the block 343, the coil spring 354 is right enough to bias the shaft 351 in the direction (clockwise) for urging the rack 347 to the right. The tension of the spring is greater, of course, in the extreme left-hand position of the rack. Also, the pinion 348 is in meshing engagement with the rack 347 throughout its travel in either direction.

My invention permits incremental or step-wise movement of the rack 347, and hence the magnetic heads 340-342. To this end, detent means are provided for effecting discrete angular movements of the control shaft 351 under the influence of the coil spring 354. I provide a detent member 360 (see FIGURE 27) on the control shaft 351 which has three spaced lugs with respective radial face portions, such radial faces being angularly spaced 120 degrees apart. Referring to FIGURES 30, 34 and 37 along with FIGURE 27, the detent member 360 is arranged immediately adjacent the upper surface of a fixed plate 361 that is secured to the base 312, as on posts 362.

The detent member 360 is located between a pair of

sleeve elements 363, 364 (FIGURE 34) which are supported on the plate 361 for pivotal movement, e.g., as on pins fixed to the plate 361. As best seen in FIGURES 34 and 37, the sleeves 363, 364 are fixed to respective U-shaped brackets 365, 366, which are respectively biased in opposite directions, as by springs 367, 368 fixed to the brackets 365, 366 and to the plate 361. The springs 367, 368 are outboard of the sleeves 353, 364, so that, as viewed in FIGURE 37, the respective brackets 365, 366 are biased counterclockwise and clockwise.

Again referring to FIGURE 37, the sleeves 363, 364 carry respective detent-engaging fingers 371, 372, which are adapted to be located in the path of the radial faces of the detent members 360. To this end, the fingers 371, 372 are normally urged against stops, shown as pins 373 fixed to the plate 361. In such positions of the fingers 371, 372, their ends are located adjacent the upper surface of the plate 361, and in the paths of the radial faces of the detent member 360.

Normally, one of the fingers 371, 372 at a time engages a radial face of the detent member 360. By subjecting the detent-engaging finger to angular movement so as to disengage the detent member, the coil spring operates to force the shaft 351, and hence the detent member 360, to be subjected to angular movement until the next radial face of the detent member comes into abutment with the end of the other finger. Such fixed angular movement, of course, effects a fixed linear travel of the rack 347 and the magnetic heads 340-342.

From the foregoing, it will be seen that by alternately disengaging the fingers 371, 372 from the detent member 360, the rack 347 and the magnetic heads carried thereby are subjected to incremental linear movements or steps, and all such steps are of the same length.

In my invention, the above-described movements of the parts are effected automatically by the magnetic tape on which sounds are recorded, and from which recorded sounds are reproduced.

Referring to FIGURES 39-41, I provide a tape cartridge 380 which includes a housing 381 having end compartments 382, 383 for supporting a pair of reels or spools 384, 385 in parallel relation. Respective lead springs 386 in one end of each compartment bias the spools 384, 385 toward the opposite end of the compartment. The housing 381 is provided with a central aperture 387 shaped to be slidable on the channel 344 in mating relation. A length of magnetic tape 388 is fixed at its ends on the hubs of the spools 384, 385. As shown, the walls of the opening 387 terminate a short distance below the top of the housing 381, and are provided with notched shelf members 389, 390 that extend into the compartments 382, 383 toward the spools 384, 385.

The portion of the tape 388 that extends between the spools 384, 385 rests on the shelf members 389, 390. Also when the cartridge 380 is moved onto the channel 340, the tape is caused to ride up onto the upper surface of the block 343 and firmly ride on the heads 340-342. For this purpose, the outer portion of the block 343 is tapered (see FIGURE 30) toward its upper end. Thus, as the cartridge 380 is moved into place on the channel 344, the inner edge of the tape engages and rides up the tapered portion of the block 343 until the lower (magnetic) surface of the tape is resting on the upper surface of the block.

To aid in holding the tape against the heads, an arm 494 (see FIGURE 30) is secured to the upper surface of the rack 347, and carries a cushion member 494' that is positioned adjacent the upper surface of the block 343. A leaf spring 495 secured to the arm 494 is disposed for engagement by the cover element 313. When the cover element is lowered, the spring 495 is urged downwardly, thereby forcing the outer end of the arm 494 downwardly. The cushion 494' thus presses the tape against the magnetic heads 340-342. When the cover element 313 is raised, the downward force on the cushion 434' is re-

moved, to permit the cartridge to be removed from or slipped onto the channel 344 without difficulty.

The upper portion of the housing 381 is formed of a removable lid 391 which has a center portion spaced sufficiently from the tape to provide clearance for the spring arm 494 and the cushion 494'. Immediately adjacent the shelf members 389, 390, the lid is provided with slots 392, 383. The slots 392, 393 are notches in the shelf members 389, 390. These aligned slots and notches are utilized, along with the tape 88, to facilitate the discrete linear movements of the magnetic heads 340-342.

Referring to FIGURE 43, the tape 388 adjacent its ends is provided with slots 396, 397. Thus, when the cartridge 380 is slipped over the channel 344 as above described, and one of the spools is rotated so that the tape 388 is taken up on one of them, the end portion of the tape fixed on the other spool has the slot therein moveable into alignment with the aligned slot in the lid 391 and the notch in the juxtaposed shelf member. For example (see FIGURE 40), the tape 388 is taken up on the spool 384, so that the slot in the end of the tape that is secured to the other spool 385 is movable into alignment with the slot 393 and notch in the shelf member 390.

To effect automatic operation or movement of the magnetic heads 340-342 by the tape, I provide arms 400, 401 (see FIGURE 34) pivotally mounted in the brackets 365, 366 for vertical movement. The arms 400, 401 at their outer ends carry runners 402, 403 that are adapted to rest on the tape 388 when the cartridge 380 is on the channel 345. Due to the arms being vertically movable, their runners 402, 402 extend through the slots 392, 393 in the lid 391 to engage the upper surface of the tape 388.

Referring to FIGURE 42, when the slot 397 in the tape 388 comes into alignment with the slot 393 in the lid 391, the runner 402 on the arm 400 moves downwardly through the slot 397. Thereupon, continued movement of the tape 388 in the same direction results in the tape at the trailing edge of the slot 397 engaging the runner 402 and forcing it therewith.

Referring to FIGURES 37 and 38, movement of the runner 402 as described above causes its arm 400, and hence the bracket 365 to which it is attached, to move clockwise against the spring 367. Where the associated finger 371 on the sleeve 363 has engaged the detent member 360, as in FIGURE 37, such movement of the arm 400 by the tape 388 forces the finger 371 away from the detent 360, thereby allowing the detent 360 to move angularly until the next radial face thereon comes into abutment with the end of the finger 372. Movement of the tape 388 in the opposite direction results in the same action as above described, i.e., at the other end of the tape, the runner 403 on the arm 401 falls into the slot 396, so that the tape at the trailing edge of the slot 396 engages the runner 403, thereby cranking it in a direction counterclockwise to disengage the finger 372 from the detent member 360, and thereby cause the detent member to undergo angular movement until it engages the finger 371. Movement of the tape 388 is effected by rotating one or the other of the spools 384, 385. Thus, referring to FIGURE 39, rotation of the spool 384 in the counterclockwise direction causes the other spool 385, through the tape 388, to rotate in the same direction, so that the tape is taken up on the spool 384, the spool 385 being the supply reel in this instance. The reverse is true when the spool 385 is subjected to clockwise rotation.

To effect rotation of the spools 384, 385, I arrange for them to be slidably positioned on shafts 410, 411 on which respective drive wheels 412, 413 are mounted. Preferably, the drive wheels have peripheral surfaces of frictional material, such as rubber or plastic. The drive wheel 412 is engaged by an idler wheel 414, so that rotation of the idler wheel 414 effects rotation of the drive wheel 412. The spools are provided with spaced openings 384', 385' (see FIGURE 39), and the drive wheels 412, 413 are pro-

vided with small plunger elements 416 (see FIGURE 27) that are biased toward the spools, as by compression springs 417. The plungers 416 extend parallel to the axes of the drive wheels in which they are located, and are spaced radially from such axes a distance equal to the radius of the circle on which the openings 384' are located.

When the cartridge 380 is slipped in place, it may be that none of the openings 384', 385' is aligned with the plungers 416 in the drive wheels 412, 413. However, due to the action of the springs 417, only slight rotation or angular movement of the drive wheels is necessary to effect driving engagement with the wheels. As soon as the drive wheel is rotated through an angle wherein the plunger is aligned with an opening in the reel, the spring 417 thrusts the plunger 416 into such opening. Thereafter, the reel and drive wheel are locked for unitary rotation.

To effect the desired operation of the spools, I utilize a unidirectional drive mechanism. Referring to FIGURES 27, 35 and 36, the drive mechanism includes a motor 420 having an output shaft 421 that rotates at a high speed, and such shaft 421 is arranged to impart rotation to a relatively large drive wheel 422, as by frictional engagement therewith. The drive wheel 422 is fixed to a floating shaft 423, which is a shaft adapted for lateral movement. At its opposite end, the shaft 423 is knurled, and is adapted to frictionally engage either the drive wheel 413 or the idler wheel 414. As shown in FIGURE 35, the knurled end of the shaft 423 is in driving engagement with the drive wheel 413, and in FIGURE 36 the knurled end of the shaft 423 is in engagement with the idler wheel 414.

In the arrangement shown, the output shaft 421 of the motor 420 is arranged to rotate clockwise so as to rotate the wheel 422 and the shaft 423 counterclockwise. Such counterclockwise rotation of the shaft 423 imparts a clockwise rotation to the drive wheel 413 (FIGURE 35), and a clockwise rotation to the idler wheel 414 (FIGURE 36). Clockwise rotation of the idler wheel 414, of course, imparts counterclockwise rotation to the drive wheel 412. Thus, when it is desired to move the tape onto the spool 384, the knurled end of the shaft 423 is brought into engagement with the drive wheel 413. Similarly, the spool 384 is subjected to counterclockwise rotation to move the tape thereon by bringing the knurled end of the shaft 423 into engagement with the idler wheel 414.

To support the shaft 423 for lateral movement, so that the knurled end thereof can be selectively positioned against either the drive wheel 413 or the idler wheel 414, I secure an elongated sleeve 425 to the shaft 423. A collar 426 is secured to the sleeve 425 adjacent the wheel 422, and the collar 426 is fixed to a pin or shaft 427 that is journaled at its lower end for rotation in the base 312. Forward of the collar 426, a further collar 428 is secured in the sleeve 425. The collar 428 is integral with a laterally extending pin 429, on which the lever 325 is mounted for pivotal movement.

Referring to FIGURES 31 and 32, the lever 325 is an L-shaped element, and has a lower arm 430 that extends alongside the sleeve 425. The end of the arm 430 carries a pair of spaced leaf spring elements 431, 432, which are arranged so as to form a substantially U-shaped end portion for the arm 430. One spring element 432 is adapted to fit against the sleeve 425, as in a notch 433 provided in the sleeve.

Movement of the shaft 423 about the pin 427 is effected by cam means carried by the main control shaft 351. Referring to FIGURES 35 and 36, there is shown a triangular-shaped cam element 436 secured to the shaft 351 immediately adjacent the base 312. In FIGURE 35, the cam element 436 is in a position wherein one corner thereof engages the spring element 432 that abuts the sleeve 425. The shaft 423 is thus held in a position wherein the knurled end thereof engages the driving wheel 413 for the reel 385.

FIGURE 36 shows the cam element 436 rotated to a position wherein one corner thereof engages the spring

element 431. Movement of the cam element 436 to this position effectively forces the arm 430 counterclockwise. Since the arm 430 is effectively secured to the sleeve 425, and hence the shaft 423, the shaft is caused to rotate about the pin 427. In the position of the cam element 436 shown in FIGURE 36, the knurled end of the shaft 423 engages the idler wheel 414 so as to effect rotation of the driver wheel 412 and the associated spool 384.

To better understand the operation of the drive shaft 423 in connection with the rotation of the spools, the movement of the tape 388, and the shifting of the magnetic heads 340-342, reference will be made to FIGURES 37 and 38, along with FIGURES 35 and 36. In FIGURE 37, as in FIGURE 35, the knurled end of the shaft 423 is in position for driving the wheel 413 and the spool 384, whereby to cause the tape 388 to be taken up on the spool 385. FIGURE 37 illustrates the situation wherein substantially all of the tape has been taken up on the reel 384, and the slot 397 in the end of the tape secured to the reel 384 is approaching the runner 402 on the arm 400. As soon as the slot 397 moves under the runner 402 (FIGURE 38) the runner 402 drops into the slot 397, whereby the tape at the trailing edge of the slot 397 engages the runner 402 and carries it with it to free the detent 360, as previously described. The ensuing incremental angular movement of the detent 360 and the shaft 351 causes the cam element 426 to move out of engagement with the spring element 432 and into engagement with the spring element 431, i.e., from the position shown in FIGURES 35 and 36 to the position shown in FIGURES 36 and 38, thereby automatically establishing the reverse direction of travel of the tape 388.

The same type of operation is performed when substantially all of the tape has been taken up on the spool 384. In such event, the slot in the end of the tape that is secured to the spool 385 moves under the runner 403 on the arm 401, thereby to actuate the arm 401 to free the detent member 360 for another incremental angular movement, and the corresponding incremental linear movement of the heads 340-342. Simultaneously with such operation of the arm 401, the cam member 426 is stepped to a succeeding position wherein it disengages the spring element 431, and engages the spring element 432, thereby moving the shaft 423 into engagement with the driving wheel 413.

The runners 402, 403 on the arms 400, 401 are shaped so that, following the operation or actuation of the arms by the tape as above-described, and ensuing reverse movement of the tape, the runners quickly and easily move out of the slots so as to ride against the upper surface of the tape. Referring to FIGURES 34 and 42, the runners 402, 403 will be seen to have their outermost edges substantially vertical, and to have lower surfaces that taper gradually upwardly from their outermost edges. Thus (see FIGURE 42), where the runner 402 drops through the slot 397 in the tape 388, the tape at the rear edge of the slot engages the vertical edge of the runner 402 and carries it with it until, in the manner previously described, the tape 388 is subjected to reverse travel. Immediately upon the tape 388 reversing its direction of movement, the tape at the opposite end of the slot engages the tapered portion of the runner 402. Because the runner is secured on a vertically movable arm, the runner 402 is cammed upwardly by the tape 388 as it moves thereunder. Accordingly, and in this manner, the runner 402 is raised to a position wherein, after the slot 397 passes to the right thereof in FIGURE 42, the runner rests on the upper surface of the tape 388.

As previously indicated, the lever 325 is also adapted to control the direction of movement of the tape. The cam member 436 being located adjacent the base 312, the lever 325 is moved forwardly (in FIGURE 26) to cause the spring elements 431, 432 to straddle the cam member 436. However, the lever 325 is also adapted to be moved rearwardly to a position so that the spring ele-

ments 431, 432 move upwardly to straddle another cam member 437 that is secured to the shaft 351. The cam member 437 is shaped like the cam member 436, i.e., substantially as an equilateral triangle. However, the cam members 436, 437 are displaced 60° with respect to each other. Thus, as best seen in FIGURE 31, for each corner of one cam member, the other cam member has a corner 180° displaced therefrom. With such arrangement, it will be seen that by moving the lever 325 forwardly and rearwardly to its extreme positions, the spring elements 431, 432 move from astride one cam member 436 to astride the other, and the shaft 423 is moved from one driving position to the other.

The lever 325 has a neutral position in which the knurled end of the drive shaft 423 is located between the driving wheel 413 and the idler wheel 414. This position is one in which the spring elements 431, 432 are located between the cam members 436, 437.

The different positions of the spring elements 431, 432 for the above-described purposes may best be seen with reference to FIGURES 32 and 33. As shown, the cam members 436, 437 are spaced along the shaft 351 a sufficient distance so that the spring elements 431, 432 will not engage the cam members when they are centered between them. The confronting ends of the cam members are cam surfaces that are tapered inwardly at the corners.

The distance between the spring elements 431, 432 is greater than the distance across the cam members. However, a tapered cam surface on each of the cam members is disposed in the path of one of the spring elements. Accordingly, when the spring elements 431, 432 are lowered to straddle the cam member 436, one spring element 432 is cammed outwardly until, in the lowermost position of the supporting arm 430, it is in biasing abutment with the cam 436.

Similarly, when the spring elements 431, 432 are moved upwardly to straddle the cam member 437, the other spring element 431 engages and is cammed outwardly by the tapered cam surface until, in the uppermost position of the supporting arm 430, the spring element 431 is in biasing abutment with the cam member 437. Due to the pivotal arrangement for the floating drive shaft 423, the shifting of the spring elements 431, 432 from one cam member to the other effects a reversal of the tape drive. In their center positions, however, both of the spring elements 431, 432 are inwardly of the outermost positions thereof, and hence the floating shaft 423 is in a neutral position.

As previously explained, the control shaft 351 is adapted automatically to undergo incremental angular movements by the tape. However, my invention also incorporates manual means for selectively effecting angular movement of the shaft 351, and hence an accompanying incremental linear movement of the rack 347 and the magnetic heads 340-342. The lever 330 (FIGURE 26) is the element that is utilized for this purpose, and its function is to selectively disengage the fingers 371, 372 from the detent member 360. To this end (see FIGURES 37 and 38) a pair of rigid leaf elements 441, 442 are secured to the fingers 371, 372, and the leaf elements 441, 442, are shaped so that their opposite ends are juxtaposed on opposite sides of a line that passes between the ends of the fingers 371, 372.

Referring to FIGURE 29 along with FIGURES 37 and 38, a bracket 443 is adapted for movement by the lever 330 along a line that extends through the juxtaposed ends of the leaf elements 441, 442. The end of the bracket 443 opposite the lever 330 is located between the juxtaposed ends of the leaf elements 441, 442. Accordingly, movement by the lever 330 of either leaf element 441, 442 away from its normal position results in pivotal movement of the associated finger 371, 372 to disengage it from the detent member 360.

The various mechanisms above described are arranged for operation to accommodate and facilitate recording

and playback procedures. Referring to FIGURE 27, the magnetic heads 340-342 are arranged so that the middle head 341 is the record-playback head, and the heads 340-342 are erase heads. The rack 347 is a hollow rod, and leads from the heads 340-342 extend through the rack 347. Two of the leads are designated R/P leads, to denote that they are connected to the record-playback head 341. Three other leads are shown extending from the rack 347, and are designated E to denote that they are connected to the erase heads 340, 342. One of the E-leads, shown as connected to a point of positive potential, is a common lead connected internally of the block 343 to both of the erase heads 340, 342.

Referring to FIGURE 44 along with FIGURE 27, the ungrounded E-leads are connected through leads 452, 453 to respective terminals of a single-pole, double-throw switch 454, the movable contact of which is connected to a point of reference or ground potential. Thus, the position of the movable contact of the switch 454 determines which of the erase heads 340, 342 is to be energized for erasing signals from the portion of the tape passing thereover.

The operation of the system is controlled through a control network 455 along with the record-listen control lever 318 and the erase head control switch 454. The same power source is utilized to provide power for the operation of the erase heads 340, 342, the motor 420 and the control network 455. Referring to FIGURE 27, the power source is shown as a battery 456 positioned in the motor casing 311. One terminal of the battery 456 is grounded, and the other terminal is connected, as at 457, to the control network and also to one end of a movable, conductive lead spring element 458 within the motor casing 311. The movable leaf spring 458 has a portion thereof juxtaposed to a contact button on a stationary conductive bus 459. The bus 459 is connected at 460 to the control network 455, and a lead 461 is connected from one terminal lead of the motor 120 to the control network 455. The remaining terminal lead of the motor 420 is connected to ground.

Referring to FIGURE 28 along with FIGURE 27, the movable leaf spring 458 is adapted for movement by the lever 318 to make and break contact with the fixed bus 459. As shown, the lever 318 is pivotally mounted on the inner wall of the motor casing 311. A tension spring 462 is fixed at its ends to the base 312 and to a portion of the lever 318 above the pivot point. The lever 318 is connected, through a pin 462 to the movable leaf spring 458. The lever 318 is adapted for movement back and forth about its pivot, and its upper end is capable of slight transverse movement away from the motor casing 311.

The leaf spring 458 is normally biased inwardly toward a position wherein it is disengaged from the bus 459. To maintain such bias, a bowed leaf spring 463 is shown affixed to the inner wall of the casing 311, with the outer end of the spring 463 engaging the leaf spring 458 to urge it out of contact with the bus 459. Such bias, of course, is also exerted through the pin 462 on the lever 318 whereby the lever 318 is biased toward the casing 311.

The lever 318 is adapted to be placed in a position (vertical) in which its upper end is immediately adjacent the casing 311. In such position, the bias spring 462 is enabled to hold the leaf spring 458 out of contact with the bus 459. However, if the lever 318 is moved in either direction from the neutral position, its upper end is forced laterally, whereby the pin 462 and the leaf spring 463 are carried outwardly sufficiently to bring the leaf spring 458 into contact with the bus 459. To this end, a rigid guide plate 464 is provided that has a flat center plate portion secured to the casing 311, and end portions that curve outwardly from the casing.

The lever 318 in its neutral position is urged into abutment with the center portion of the guide plate 464. When

the lever is moved in either direction off neutral, its upper portion is forced onto the curved portions of the guide plate, thereby causing the leaf spring 458 to move inwardly to contact the bus 459.

In the above-described operation of the lever 318, the motor 420 is off when the lever is in its neutral position, and on when the lever is on either side of its neutral position. The completed connection of the battery 456 to the motor 420 (in the off-neutral positions of the lever 318) is effected through suitable switching in the control network 455. Since the battery must be connected to the erase heads 340, 342 only for recording, such switching is synchronized with the movements of the lever 318. Thus, when the lever 318 is in "record" position, one or the other of the erase heads is connected to the battery 456. However, neither of the erase heads is connected to the battery when the lever 318 is in the "listen" position.

The necessary switching of the battery, for connection to the erase heads only for recording, is synchronized with the operation of the microphone and loudspeaker. As shown in FIGURE 27, a microphone 465 is connected to a fixed contact of a single-pole, double-throw switch 466, and the movable contact and the remaining fixed contact of the switch 466 are connected through respective leads 467, 468 to the control network 455. Also, a loudspeaker 469 is connected to the fixed terminal of a single-pole switch 470 that has its movable contact connected through a lead 471 to the control network 455.

The switches 466, 470 are ganged for operation by the record-listen control lever 318, as indicated by a mechanical connection 472. By such arrangement, the lever in its "listen" position positions the switches 466, 470 so the loudspeaker 469 is connected to the control network, the microphone 465 is disconnected, and the leads 467, 468 are connected together. When the lever 318 is moved to the "record" position, the switches 466, 470 are positioned so that only the microphone 465 is connected to the control network.

FIGURE 44 shows circuit connections for permitting operation of the erase heads only during recording. The switch 470 to the loudspeaker 469 is shown ganged with another switch 473 that is connected between the switch 454 and the negative terminal of the battery. The switch 473 is open when the loudspeaker 469 is connected to the control network, and is closed (to make the erase heads operative) when the loudspeaker is disconnected from (and the microphone is connected to) the control network.

The switch 473 will be understood to be included in the control network. Within the control network, it will also be recognized that suitable amplifiers are arranged for connection to the microphone 465 and the loudspeaker 469, as in the manner disclosed in my copending application. As in such copending application, when the microphone 465 is disconnected, the leads 467, 468 connect the R/P leads to amplifier networks that are coupled to the loudspeaker 469.

Although the reversal of tape travel may be effected in the various ways previously described, there is a definite relationship between the direction of tape travel and the position of the heads 340-342, i.e., the line or track adjacent which the heads are positioned. To better understand this, reference will be made to FIGURES 27 and 43. It is assumed that the tape shifting mechanism has been "wound up," i.e., the control knob has been turned to cause the pinion 348 to move the rack 347 rearwardly, until the heads 340-342 are located adjacent the inner edge of the tape 388. Also assume that the tape is on the spool 384, and that the direction control lever 325 is forward, so that the spring elements 431, 432 carried thereby straddle the lower cam member 436, in which case the knurled end of the floating drive shaft 423 is in driving engagement with the drive wheel 413. The motor is set or connected to the battery 456, and drives

the spools clockwise so as to feed the tape onto the spool 385. This direction of travel is indicated by the solid arrow in FIGURE 43. The relative movement of the heads 340-342 with respect to the tape, of course, is in the opposite direction.

For the assumed positions of the parts and the direction of tape travel, the control lever 318 is in the "record" position. Through the microphone 465, signals are fed through the control network and the R/P leads to the record-playback head 341, thereby to cause signals to be recorded on the tape. It is, of course, necessary that any recorded material on the tape be erased immediately preceding the passage of the tape over the record-playback head 341. For such assumed direction of travel, this means that the erase head 340 is energized to erase whatever is on that track before it reaches the head 341.

After the tape has been fed onto the spool 385, and the direction of travel of the tape is reversed simultaneously with a linear step movement of the heads 340-342 to the right, it is necessary to de-energize the erase head 340 and energize the erase head 342.

I control the operation of the erase heads during recording through the head shifting mechanism. Referring to FIGURES 35, 36, I do this by providing the switch 454 with a plunger 478, and providing a pivotal lever 479 that is operable by the lower cam member 436 on the shaft 351. The switch 454 is arranged so that the movable contact thereof is movable with the plunger 478 to engage one fixed contact when the plunger 478 is in an outer position, and to engage the other fixed contact when the plunger 478 is depressed. In FIGURE 35, the plunger 478 is shown in an undepressed position, which condition is allowed by virtue of the end of lever 479 extending along one side of the cam member 436. Since the knurled end of the floating drive shaft 423 engages the drive wheel 413 in this position of the parts, so that the tape is being turned onto the spool 385, the condition of the switch 454 in FIGURE 35 is one in which the erase head 340 is energized.

FIGURE 36 shows the position of the parts when the heads are shifted to a position in which the cam member 436 brings the knurled end of the floating drive shaft 423 against the idler wheel 414. The cam member 436 in this position forces the lever 479 clockwise sufficiently to depress the plunger 478, and thereby cause the other erase head 342 to be energized.

If it is desired to step back along the line or track on which signals are being recorded, it is necessary only to move the lever 325 to the "Rev." position, and to move the record-listen control lever to the "listen" position. By such manipulation of the levers, only the direction of movement of the tape is reversed, i.e., the lever 325 does not alter the position of the control shaft 351, and hence does not affect the position of the heads 340-342. Furthermore, the tape in such reverse movement cannot effect actuation of the head shifting mechanism, even if the slot therein is brought under the associated runner. To this end (see FIGURE 34), the runners 402, 403 are lifted and held out of engagement with the tape when the lever 325 is in the "Rev." position. The arms 400, 401 are connected by a rod 480, which is engaged by one end of a lever arm 481. The lever arm extends above the support plate 361, across a pin 482 that is supported above the support plate 361, and under a pin 483 that is secured to the lever 325.

The pin 482 forms a fulcrum for the lever arm 481. The free end of the lever arm is curved upwardly, so that when the lever 325 is moved rearwardly (to the "Rev." position), the pin 483 on the lever 325 cams the lever arm 481 downwardly, whereby to cause the rod 480, and hence the arms 400, 401, to be raised. In the "Rev." position of the lever 325, the arms 400, 401 are held in a position wherein the runners 402, 403 cannot fall into the slots in the tape.

With the lever 325 in the "Rev." position, and the

lever 318 in the "listen" position, the tape travels in the reverse direction until it is wound up on the spool 384 (in the assumed situation). Thereupon, tape travel would stop, i.e., the knurled end of the floating drive shaft would simply turn against the idler wheel 414 until the tape was again set into operation in the forward direction, i.e., until the forward-reverse control lever 325 was again moved to the forward ("Fwd.") position. After thus backing up and resuming forward movement of the tape along any line, and with the lever 318 in the "listen" position, the previously recorded material is reproduced in the loudspeaker.

When it is desired to replace a cartridge, the lever arm 481 is manipulated to raise the runners 402, 403 clear of the plane in which the magnetic heads 340-342 are located, and in which the tape is to be placed. This operation may be done manually, or it may be effected automatically, as through a bias spring element (not shown) adapted to be held clear of the lever arm 481 by the cover element 313 until such cover element is raised for replacing cartridges.

It may also be desired at any time to shift the positions of the heads 340-342 to any desired track on the tape. For this purpose, the control knob 332 may be turned in the rewind direction, so as to shift the heads to a position to the left of that in which they are currently located. Or the control lever 330 may be actuated to shift the heads forwardly, i.e., to the right, of the position in which they are currently located. In such manual operations, there is no effect on the coordinated arrangement of head position and direction of tape travel. Since either the control knob 332 or the control lever 330 effects an operation of the control shaft to step the heads incrementally, and since any stepping to the heads occurs simultaneously with the shift in the direction of rotation of the floating drive shaft (and hence a direction of travel of tape), the tape will be in the proper direction of travel for any position of the heads 340-342.

As previously indicated, the numbered disc 329 aid in identifying for the operator the track of the tape on which the heads are located. Referring to FIGURES 26, 27 and 29, the disc 329 is secured to a rotatable shaft on which a gear 485 is fixed in meshing engagement with the pinion 348. Thus, since the angular position of the pinion 348 corresponds to the linear position of the rack 347, and hence of the heads 340-342, the angular position of the gear 480 also corresponds to the position of the heads 340-342. The numbers on the peripheral edge of the disc 329 are positioned so as to denote, adjacent the index 328 seen through the openings 327, the track position of the heads.

FIGURES 45-50 illustrate another form of tape cartridge and associated drive means which can be used in apparatus as heretofore described. As shown (FIGS. 45-48), the cartridge includes a housing 510 having a thick internal section 511. The inner surface of the section 511 is formed with a pair of curved portions 512, 513, each having a radius of curvature to match that of the flanges of the spools 514, 515 on which the magnetic tape 516 is carried.

The section 511 may be a molded insert, e.g., of plastic. The top surface of the section 511 is spaced sufficiently below the top of the housing 510 to provide a space or channel for the tape. When the spools 514, 515 are located in the housing, the tape 516 thereon is passed between the spools and rods 518, 519 which extend through the housing outboard of and parallel to the spools 514, 515, and passed through the space between the section 511 and the top of the housing. The rods aid in locating the spools 514, 515.

The end surfaces of the section 511 are spaced from the ends of the housing, to facilitate looping the tape over the section 511 in assembly of the cartridge. Also, the ends of the section 511 are tapered, so that the section is generally trapezoidal in shape. Preferably, the end surfaces of the section 511 are concave.

In the opposite side of the housing, slotted openings 523, 524 are provided which have their outermost ends aligned with the respective openings 521, 522, and the innermost ends of the slotted openings 523, 524 are aligned with the innermost portions of the tapered end surfaces of the section 511.

Referring to FIGURE 47, it will be seen that, by virtue of the shapes of the section 411 and the openings, when the tape 516 is passed over the top surface of the section 511, there is a substantial clearance between the tape and the ends of the shorter side of the section 511. The significance of this arrangement will be seen in the following description of FIGURES 49 and 50.

Referring to FIGURE 49, there is illustrated drive means including a pair of capstans 531, 532 which are supported adjacent their inner ends in bearing sleeves 533, 534 that are mounted for pivotal movement, as at 535, 536, e.g., as on the base of the tape recorder units heretofore described. Discs or wheels 538, 539 to be driven are secured to the inner ends of the capstans.

The capstans 531, 532 have their outer ends normally biased toward each other. By way of example, a tension spring 540 is connected to both capstans outwardly of their pivots, and urges the capstans inwardly to positions limited by stops 541, 542. The ends of the spring 540 are shown placed in grooves in the capstans, and are so arranged to permit the capstans to rotate freely therein.

In the innermost positions of the capstans, their outer ends are in position to be engaged by the inner portions of the end surfaces of the section 511, when one positions the cartridge 510 so as to move it into place on the recorder housing. To aid in this regard, the outer ends of the capstans are tapered, to insure their entering the space between the tape and the end surfaces of the section 511.

Referring to FIGURES 49 and 50, it will be seen that as the cartridge is moved into position on the recorder housing, the end surfaces of the section 511 effectively cam the capstans outwardly. While thus being cammed, the capstans move the tape outwardly with them. When the cartridge is locked in place on the recorder, the capstans are parallel, the tape is taut, and rotation of the capstans in unison effects tape travel in the desired manner. The cartridge may be locked in place in any suitable manner, as by means (not shown) of the types heretofore mentioned.

The shapes of the section 511 and the openings 523, 524 are chosen to insure that the capstans are cammed outwardly to parallel positions. If desired, the section may be rectangular in shape, in which case the openings 523, 524 are shaped, e.g., pear-shaped, to effect the desired movement of the capstans.

In the parallel positions of the capstans, their outer ends extend through the openings 521, 522. These outer ends are bearing caps 531', 532' which are rotatably mounted on the ends of the capstans. These end caps 531', 532' are frictionally held in the circular openings 521, 522. Lateral play of the capstans is thus substantially eliminated because each capstan rotates within spaced bearings.

The capstans are rotated in opposite directions continuously. As viewed in FIGURE 50, these directions are clockwise for the right-hand capstan 532, and counterclockwise for the other capstan 531. Such rotation is effected by a knurled drive member 544, which engages one of the discs, e.g., the disc 539, and rotates in the proper direction (counterclockwise) to drive the capstans in the proper directions. As will be appreciated, the drive member 544 is undirectional, in which case drive connections may be employed as in the embodiment of FIGURES 26-44.

Referring again to FIGURES 45-47, the section 511 is provided with a central depression 545 in its top surface. This arrangement permits the tape to slide between the magnetic heads and a pressure pad when the cartridge is moved onto the recorder housing.

As will be noted in FIGURE 45, the top of the housing 510 is provided with openings 546, 547, for the same purpose as in the embodiment of FIGURES 26-44. In this connection, it should be noted that the section 511 also has openings 548, 549 aligned with the openings 546, 547, whereby to provide clearance space into which the runners may move when the openings in the tape pass under them.

To facilitate assembly of the tape-filled cartridge, the housing 510 may be formed in two parts 541, 552. The rods 518, 519 are integral with one section 512, and both parts 551, 552 of the housing have slots in their top surfaces so as to form the openings 546, 547 when they are secured together.

The section 511 is positioned in one part 552 of the housing. The spools 514, 515 with the tape 516 thereon are positioned to fit in the curved wall portions 512, 513. Then the tape is looped over the section 511. The other part 551 of the housing is then secured in place. In this connection, the parts of the housing may be secured together by screws 554 for securing the part 551 to the outer ends of the rods 518, 519, and by screws 555 for securing the part 551 to the section 511.

The housing is shown to have a pair of openings 556, 557 in its side (see FIGURES 46, 47). When the cartridge is moved into place on the recorder unit, the openings 556, 557 receive suitable support elements which enter the spools 514, 515.

Referring to FIGURE 50, movement of the tape is aided by pressure rollers 561, 562 which straddle the cartridge. These rollers are shown to be linked together and spaced a distance such that only one roller at a time can engage the tape. In this connection, the corners of the housing are cut away, to provide access openings 563, 564 to permit the rollers to engage the tape and press it against the associated capstans. To move the tape, say, from left to right, the rollers 561, 562 are moved to the left to permit the right-hand roller 562 to engage the tape. Similarly, the rollers are moved to the right, to permit the left-hand roller 561 to engage the tape, in order to move the tape from right to left.

One means for shifting the rollers to effect tape reversal is indicated as a connection to the arm 430 of the mechanism shown in FIGURES 26-44. Since the drive element 544 rotates the capstans constantly during recording and playback, the arm 430 is mounted separately on the base plate, so that the drive shaft is stationary, i.e., not subjected to shifting upon operation of the cam. The linkage between the arm 430 and the rollers 561, 562 causes the rollers to be shifted in the direction in which the appropriate control arm 400, 401 is moved upon being engaged by the tape.

While I have described certain embodiments of tape cartridges and accommodating tape drive and line switching means, it will be apparent that various modifications may be made without departing from the spirit and scope of my invention. Accordingly, I do not intend that my invention shall be limited, except as by the appended claims.

I claim:

1. In combination with a length of magnetic tape having its ends secured to a pair of reels, and a transducer to be moved transversely of the tape, a tape drive and transducer positioning control system comprising:

a unidirectional motor having an output shaft;
shaft means to be coupled to said output shaft for driving said reels and tape;

coupler means rotatable by said output shaft for coupling said shaft means to said output shaft, said coupler means being movable between two positions wherein it causes said shaft means to rotate in opposite directions;

an elongated rack member carrying said transducer at one end thereof;

a pinion member engaging said rack and rotatable to impart longitudinal movement to said rack member;

cam means for moving said coupler means between its two positions;

and a rotatable control shaft mechanically coupled to said pinion member and cam means, said cam means being operable to cam said coupler means alternately between its two positions a plurality of times during a revolution of said control shaft.

2. Apparatus as set forth in claim 1, wherein said tape has a surface irregularity adjacent each end thereof; means positioned in the paths of said surface irregularities and responsive thereto to move said control shaft through a predetermined angle, said cam means being operable during each such control shaft movement to force said coupler from one to the other of its two positions.

3. Apparatus as set forth in claim 1, wherein said responsive means includes:

a ratchet wheel secured to said control shaft;

pawl means to engage said ratchet wheel for moving said control shaft through said predetermined angle; electromagnetic means adapted to operate said pawl means;

circuit means for energizing said electromagnetic means and having normally open switch means in the paths of travel of said tape surface irregularities, said surface irregularities when adjacent said switch means permitting said switch means to close and cause said electromagnetic means to be energized.

4. A combination as defined in claim 1, including:

means biasing said shaft for rotation in a direction to effect movement of said rack element in one direction along said line;

a detent member on said shaft;

and detent-engaging elements carried by said actuating elements and arranged to alternately engage said detent member.

5. A combination as defined in claim 4, including:

drive means for said reels including drive wheels coupled to said reels;

a rotatable drive shaft for said coupler means having one end located between said drive wheels; means supporting said drive shaft for pivotal movement laterally;

and said cam means operable by the said control shaft to pivot said drive shaft alternately between positions of driving engagement of said one end thereof with said drive wheels.

6. A combination as defined in claim 5, including:

a cam member on the shaft of said control means, said cam member having spaced projections arranged so that a projection is directed toward said drive shaft in every other position of the shaft of said control means;

and an arm parallel to said drive shaft and fixed to said drive shaft supporting means, said arm being operable by said cam member projections to move said drive shaft back and forth between its two positions.

7. A combination as defined in claim 6, including:

a pair of leaf spring elements on said arm straddling said cam member, said leaf springs being alternately engaged by said cam member in successive positions of the shaft of said control means.

8. A combination as defined in claim 7, including:

a manually operable lever supporting said arm, said lever being pivotally mounted on said drive shaft supporting means, whereby to permit said arm to be moved axially of the shaft of the control means and out of engagement with said cam member, said drive shaft being out of engagement with either drive wheel when said arm is out of engagement with said cam member.

9. A combination as defined in claim 8, including:

a further cam member on the shaft of said control means, said cam members being spaced, each cam

member having projections so angularly spaced from those on the other cam member that movement of said arm from engagement with one cam member to the other effects pivotal movement of said drive shaft from driving engagement with one drive wheel into driving engagement with the other drive wheel.

10. A magnetic tape recorder comprising:

an elongated horizontal base plate;

a channel member affixed to said base plate at one end thereof;

a block element slidable in said channel member;

a pair of spaced erase heads embedded in the upper surface of said block along a line transverse to the direction of movement of said block;

a record-playback head embedded in the upper surface of said block intermediate said erase heads;

a tape cartridge having spaced compartments supporting a pair of spool-like reels, the confronting walls of said compartments being astride said channel member and in slidable engagement therewith;

a pair of horizontal parallel shafts for slidably receiving said reels;

means for supporting said parallel shafts in fixed spaced relation;

respective drive wheels on said parallel shafts;

reel-engaging projections on said drive wheels;

a length of tape affixed at its ends to said reels;

an idler wheel in frictional engagement with one drive wheel;

drive means having a shaft shiftable between said idler wheel and the other drive wheel for effecting rotation of the drive wheels in opposite directions;

a vertical shaft journaled in said base plate;

a pinion on said vertical shaft;

an elongated rack element operable by said pinion, said rack element being fixed at one end to said block;

a detent member on said vertical shaft;

a pair of detent-engaging elements supported on said base plate for pivotal movement;

means biasing said detent-engaging elements toward said detent member, said detent member being shaped to be engaged by only one detent-engaging member at a time;

a coil spring surrounding said vertical shaft and fixed at its ends to said vertical shaft and said base plate, said spring biasing said shaft for rotation in a direction to cause said pinion to move said rack element toward the outer end of said channel member;

and respective actuating arms for said detent-engaging elements adapted for engagement by the end portions of said tape.

11. A recorder as defined in claim 10, including:

an L-shaped lever having an arm carrying spaced leaf spring elements, said arm being movable laterally with said drive shaft, said leaf spring elements straddling said vertical shaft;

and a pair of spaced cam members on said vertical shaft, said lever being movable to place said leaf spring elements astride either cam member, each cam member being arranged, when straddled by said leaf spring elements, to hold said arm in a position in which said drive shaft is in driving engagement with either said idler wheel or said other drive wheel, said cam members also being arranged so that upon moving said arm from one to the other in any position of said vertical shaft, said drive shaft is shifted from one to the other of said idler wheel and said other drive wheel.

12. A recorder as defined in claim 11, including:

a pair of electrical connections to each of said heads extending through said rack element, one connection to each erase head being connected to one connection to the other erase head to form a common connection;

a single-pole, double-throw switch having fixed contacts

33

respectively connected to the remaining connections to said erase heads, said switch having a movable contact to be connected to one or the other of the fixed contacts;
 means for effecting movement of said movable contact 5
 by one of said cam members;
 a microphone and a loudspeaker supported by said base plate;
 and control means for selectively connecting said microphone and loudspeaker to the connections to said 10
 record-playback head, said control means connecting said erase current source to said movable con-

34

tact only when said microphone is coupled to said record-playback head.

References Cited

UNITED STATES PATENTS

2,793,253	5/1957	Howey	-----	179—100.2
2,933,319	4/1960	Proctor	-----	179—100.2
3,016,522	1/1962	Lourie et al.	-----	179—100.2
3,205,316	9/1965	Hechler	-----	179—100.2

BERNARD KONICK, *Primary Examiner*.

V. P. CANNEY, *Assistant Examiner*.

UNITED STATES PATENT OFFICE
CERTIFICATE OF CORRECTION

Patent No. 3,383,473

May 14, 1968

Richard E. Schroter

It is certified that error appears in the above identified patent and that said Letters Patent are hereby corrected as shown below:

Column 31, line 49, cancel "a cam member on the shaft of said control means, said" and insert -- a cam member on said control shaft, said --.

Signed and sealed this 14th day of October 1969.

(SEAL)

Attest:

Edward M. Fletcher, Jr.

Attesting Officer

WILLIAM E. SCHUYLER, JR.

Commissioner of Patents