

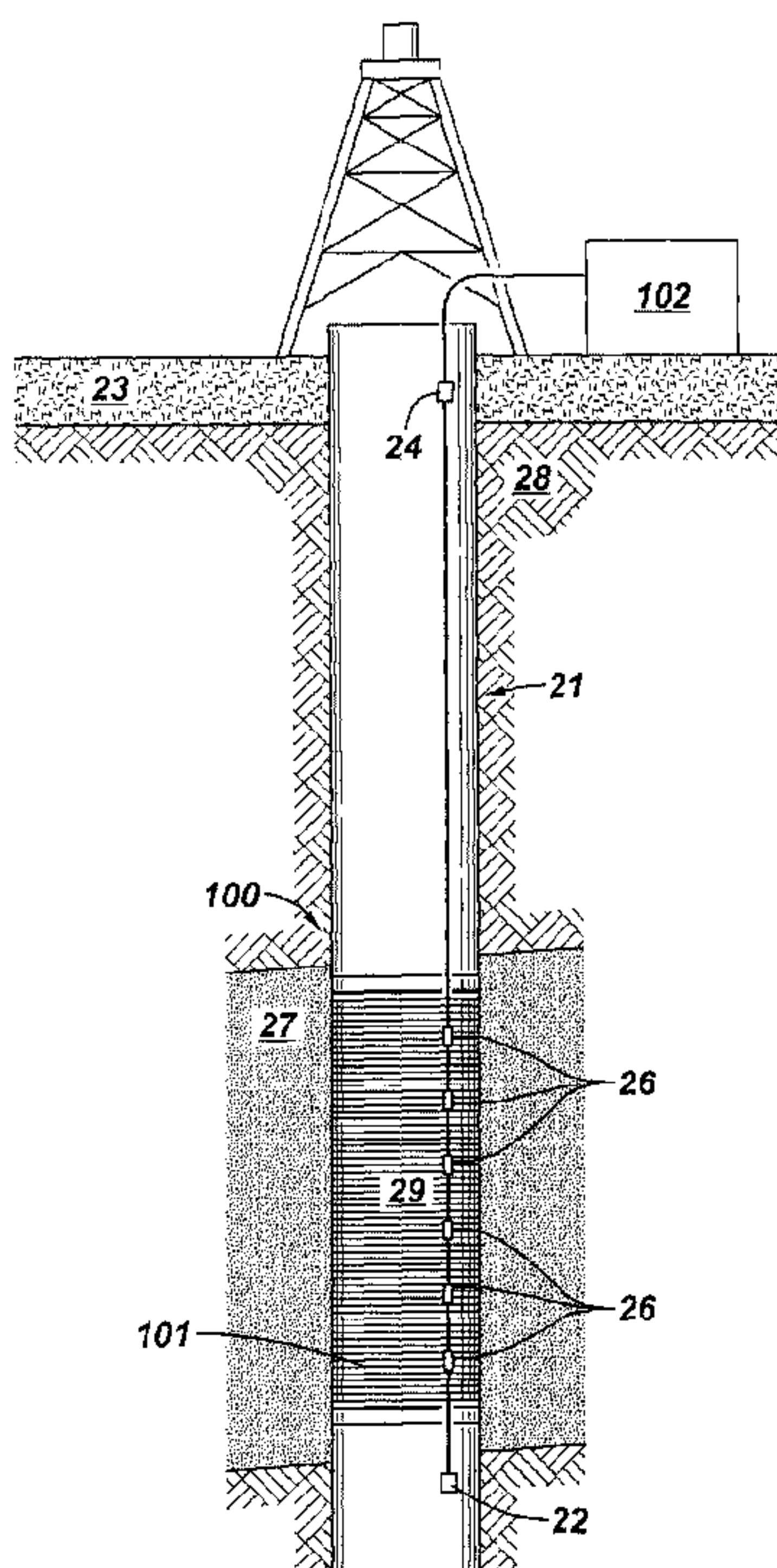

(22) Date de dépôt/Filing Date: 2010/07/08
 (41) Mise à la disp. pub./Open to Public Insp.: 2011/01/10
 (45) Date de délivrance/Issue Date: 2017/06/20
 (30) Priorité/Priority: 2009/07/10 (US61/224,636)

(51) Cl.Int./Int.Cl. *E21B 47/07* (2012.01),
E21B 47/00 (2012.01), *G01N 33/24* (2006.01)
 (72) Inventeur/Inventor:
LOVELL, JOHN, US
 (73) Propriétaire/Owner:
SCHLUMBERGER CANADA LIMITED, CA
 (74) Agent: SMART & BIGGAR

(54) Titre : METHODE ET APPAREIL POUR SURVEILLER LA REFORMATION ET LE REMPLACEMENT D'HYDRATES DE GAZ CO₂/CH₄
 (54) Title: METHOD AND APPARATUS TO MONITOR REFORMATION AND REPLACEMENT OF CO₂/CH₄ GAS HYDRATES



(57) Abrégé/Abstract:

A method for monitoring production from a methane hydrate reservoir includes obtaining a plurality of temperature measurements in a wellbore connected with the methane hydrate reservoir; and deriving a parameter relating to conversion of methane hydrate to

(57) **Abrégé(suite)/Abstract(continued):**

carbon dioxide (CO₂) hydrate by injection of liquid CO₂, wherein the deriving uses a modeling program and the plurality of temperature measurements, wherein the modeling program uses at least one parameter relating to a thermodynamic properties that are substantially different between methane and CO₂. The at least one parameter relating to thermodynamic properties may include Joule-Thomson coefficients of methane and CO₂. The parameter relating to the conversion of methane hydrate to CO₂ hydrate may include a ratio of methane and CO₂ in a mixed fluid.

METHOD AND APPARATUS TO MONITOR REFORMATION AND REPLACEMENT OF CO₂/CH₄ GAS HYDRATES

ABSTRACT

A method for monitoring production from a methane hydrate reservoir includes obtaining a plurality of temperature measurements in a wellbore connected with the methane hydrate reservoir; and deriving a parameter relating to conversion of methane hydrate to carbon dioxide (CO₂) hydrate by injection of liquid CO₂, wherein the deriving uses a modeling program and the plurality of temperature measurements, wherein the modeling program uses at least one parameter relating to a thermodynamic properties that are substantially different between methane and CO₂. The at least one parameter relating to thermodynamic properties may include Joule-Thomson coefficients of methane and CO₂. The parameter relating to the conversion of methane hydrate to CO₂ hydrate may include a ratio of methane and CO₂ in a mixed fluid.

78543-326

METHOD AND APPARATUS TO MONITOR REFORMATION AND REPLACEMENT OF CO₂/CH₄ GAS HYDRATES

[0001]

BACKGROUND OF INVENTION

Field of the Invention

[0002] The present invention generally relates to measurements of fluid flows in downhole applications, more particularly to the use of measurements to determine gas ratios in the fluid flows, and other related applications.

Background Art

[0003] Natural gas hydrates, such as methane hydrates, may be formed from natural gas (e.g., methane) and water by the decomposition of microorganisms at low temperature and high pressure. Natural gas hydrates are abundant around the world, including large known deposits below permafrost and in deep sea beds. Energy-supply research estimates indicate that these natural gas hydrates contain more energy than all other fossil fuel deposits combined. However, technology needed to recover large amounts of natural gas from hydrate has proven to be economically challenging.

[0004] Research programs are underway to reform natural gas hydrate to produce large volumes of useable hydrocarbon fuels, particularly methane (CH₄), by injection of liquid

CO₂ into the natural gas (CH₄) hydrate to convert the natural gas hydrate into CO₂ hydrate and CH₄ gas. Thus, natural gas can be released in a form that can be readily recovered using conventional means. For example, Komai et al. (Preprints, Div. of Fuel Chemistry, ACS National Meeting 1997, San Francisco, 568-572) discuss the use of liquid CO₂ to convert methane hydrates and release CH₄ gases while absorbing CO₂. This may represent a cost-effective and environmentally safe method for simultaneous CO₂ sequestration and CH₄ production during conversion of the hydrates.

[0005] The conversion of CH₄ hydrate into CO₂ hydrate is a near thermo-neutral process, and, therefore, there is no need to supply heat to the hydrates. Although CO₂ hydrate is known to be slightly more stable than CH₄ hydrate under the same pressures and temperatures, this does not mean that the conversion is straightforward. For example, too much pumped liquid CO₂ may fracture the rock, whereas too little liquid CO₂ may lead to conversion only on the exterior of CH₄ crystals. One way to overcome this problem is by adding acid catalysts to the pumped liquid CO₂ to speed up the conversion from liquid CO₂ and methane hydrate to CO₂ hydrate and gaseous methane. For example, U.S. Patent No. 6,733,573, issued to Lyon, discloses the use of acid catalysts to accelerate the conversion. However, this method also comes with its own challenges, e.g., too much of acid catalysts may cause the wellbore to collapse, etc.

[0006] Therefore, there is a need to monitor both the downhole conversion of CH₄ hydrate into CO₂ hydrate and the ratios of the two components in fluids produced to the surface. To ensure efficient operations, it would be appropriate to also monitor the

production of water from any of the zones, because water production may cause the rapid formation of hydrates, which may plug the wellbore.

SUMMARY OF INVENTION

[0007] One aspect of the invention relates to methods for monitoring production from a methane hydrate reservoir. A method in accordance with one embodiment of the invention includes obtaining a plurality of temperature measurements in a wellbore connected with the methane hydrate reservoir; and deriving a parameter relating to conversion of methane hydrate to carbon dioxide (CO₂) hydrate by injection of liquid CO₂, wherein the deriving uses a modeling program and the plurality of temperature measurements, wherein the modeling program uses at least one parameter relating to a thermodynamic properties that are substantially different between methane and CO₂. The at least one parameter relating to thermodynamic properties may include Joule-Thomson coefficients of methane and CO₂. The parameter relating to the conversion of methane hydrate to CO₂ hydrate may include a ratio of methane and CO₂ in a mixed fluid.

[0008] One aspect of the invention relates to systems for monitoring production from a methane hydrate reservoir. A system in accordance with one embodiment of the invention includes: a temperature sensing system for measuring temperature in a well connected with the methane hydrate reservoir; and a processor having a program for determining, based on temperatures measured by the temperature sensing system, a ratio of components in a mixed fluid, wherein the program makes use of a thermodynamic property of individual components in the mixed fluid.

78543-326

[0009] One aspect of the invention relates to systems for monitoring production from a methane hydrate reservoir. A system in accordance with one embodiment of the invention includes a processor and a memory storing a program having instructions for: deriving a parameter relating to conversion of methane hydrate to carbon dioxide (CO₂) hydrate by injection of liquid CO₂, wherein the deriving uses a modeling program and a plurality of temperature measurements obtained in a wellbore connected with the methane hydrate reservoir, and wherein the modeling program uses at least one parameter relating to a thermodynamic properties that are substantially different between methane and CO₂.

[0010]

BRIEF DESCRIPTION OF DRAWINGS

[0011] FIG. 1 shows a schematic illustration of a prior art wellbore for using temperature measurements to estimate flow rates.

[0012] FIG. 2 shows a schematic illustration of a wellbore for production from methane hydrate reservoirs in accordance with one embodiment of the invention.

[0013] FIG. 3 shows a flowchart of a method for monitoring conversion of methane hydrate with liquid CO₂ in accordance with one embodiment of the invention.

[0014] FIG. 4 shows a flowchart of a method for determining ratios of CH₄ and CO₂ in accordance with another embodiment of the invention.

[0015] FIG. 5 shows a flowchart of a method for determining ratios of components in a mixed fluid in accordance with another embodiment of the invention.

DETAILED DESCRIPTION

[0016] Embodiments of the present invention relate to methods and systems for monitoring production of natural gas (CH_4) from conversion of methane (CH_4) hydrate by injection of liquid CO_2 . Embodiments of the invention use well measurements (e.g., temperature and pressure measurements) to monitor production of CH_4 from gas hydrate by injection of liquid CO_2 . In accordance with embodiments of the invention, the ratios of CH_4 and CO_2 may be determined by taking advantage of the different thermodynamic properties of the two components. In particular, ratios of CH_4 and CO_2 may be derived from monitoring the Joule-Thompson coefficients of the produced fluids.

[0017] In accordance with embodiments of the invention, the flow properties may be derived from temperature measurements, which may be obtained using any suitable sensors and systems known in the art, such as digital temperature sensors, optical sensors (e.g., based on Raman or Fiber-Bragg technology) or traditional distributed temperature sensing (DTS) systems, among others. Some embodiments of the invention also make use of additional sensors (e.g., pressure sensors), which may provide additional information to help produce more stable inversion.

[0018] Methods for monitoring flow rates from temperature measurements in conventional oil wells are known in the art. For example, U.S. Patent Application Publication No. 2005/0149264, by Tarvin et al., discloses a distributed temperature sensor system to measure a temperature profile in a well, which is processed according to

a well model that relates thermal characteristics (e.g. thermal decay and/or amplitude of a thermal discontinuity at an injection point) to flow rates.

[0019] Similarly, Pinzon et al, in SPE Paper 110064, entitled “Monitoring Production from Gravel-Packed Sand-Screen Completions on BP Azeri Field Wells using Permanently Installed Distributed Temperature Sensors,” discloses the use of a permanently installed fiber-optic distributed temperature monitoring system to monitor production rates and changes over time.

[0020] U.S. Patent No. 6,618,677, issued to Brown, also discloses a fiber optic sensor system for providing temperature information to determine the mass flow rates of produced fluids within a well bore. According to this method, mass flow rates of fluids in a conduit in contact with heat sinks differing in temperature from the fluids are determined by: (1) obtaining a distributed temperature profile of fluid flowing along a length of conduit using optical data obtained from a length of optical fiber in thermal contact therewith, (2) obtaining a profile of the heat sink temperature external to the conduit, and (3) deriving mass flow rates of fluids in the conduit from the said profiles and from measured thermal transfer parameters.

[0021] Embodiments of the invention may use any suitable methods for temperature measurements and flow characterization in a well. For example, FIG. 1 shows a prior art fiber optic system for measuring temperatures and for analyzing flow characteristics in a well according to U.S. Patent No. 6,618,677, issued to Brown.

[0022] FIG. 1 shows an oil well with a casing **11** extending from the surface **12** through a producing reservoir **13**. A production tubing **15** is installed inside the casing **11** from a

78543-326

flow control apparatus 16 through a production packer 18 to reach a producing zone 17. An optical fiber is deployed in a suitable duct 20 for temperature measurements. The fiber optic system includes a light source (a laser), a light detector, and a data processing unit 22. The processing unit is for interpreting temperature- and location-related characteristics of the returned light in terms of the temperature profile at a series of locations along the fiber.

[0023] The graph on the right hand side of FIG. 1 illustrates temperature profiles along the length of the well. The natural geothermal profile 30 is a straight line relation between the depth and temperature. It may be derived from simple temperature measurements, using conventional sensors, at different depths. Curve 32 represents a distributed temperature profile of the fluids in the production tubing. As fluid enters the well from the reservoir and rises in the production tubing, it passes into cooler regions and begins to lose heat to the surrounding formations. Depending on flow rates, thermal conductivities and the like, the temperature of the fluid rising in the well falls at different rates. Therefore, the mass flow rates of the fluids may be determined based on the distributed temperature profiles using predetermined algorithms. Two exemplary methods (algorithms) are disclosed in U.S. Patent No. 6,618,677.

[0024] In injection wells, methods for determining flow properties using the temperature measurements along the sandface are also available. The temperatures can be monitored during injection. In addition, the temperatures can also be monitored after injection, as the temperatures of the reservoir increase. See for example, Witterholt and Tixier,

“Temperature Logging in Injection Wells,” SPE 4022, and for gas production, Tixier and Kunz, “Temperature Surveys in Gas Producing Wells,” AIME Annual Meeting, Chicago 1955.

[0025] Some embodiments of the invention relate to measuring the hydrate conversion – i.e., conversion from CH₄ hydrate to CO₂ hydrate. As noted above, in a typical operation, liquid CO₂ is pumped downhole to displace CH₄ from the hydrate. Such conversion, though thermally neutral, is not always facile. Therefore, monitoring of such conversions is important to ensure that the conversion is efficient.

[0026] A method for monitoring the CO₂ and CH₄ conversion in accordance with embodiments of the invention may include the steps of: (1) measuring the temperatures along sections of a completion as liquid CO₂ is being injected into a wellbore, (2) allowing the wellbore to warm up while monitoring the temperature changes, and (3) then making inferences regarding the conversion of CH₄ hydrate to CO₂ hydrate and the radial penetration of the liquid CO₂ based on the temperature profiles.

[0027] In accordance with embodiments of the invention, the making inference (deriving) may be performed by combining the temperature measurements with a modeling program that can solve the hydrate conversion and iterate between the computed temperatures and the measured warm-back temperatures. Any suitable temperature modeling software may be used, such as that sold by Schlumberger under the trade name ThermaTM.

[0028] Some embodiments of the invention relate to using temperature (and optionally pressure) measurements performed at post-injection of liquid CO₂ to determine the ratios

of CH₄ to CO₂ in the produced fluids. A method in accordance with one embodiment of the invention, for example, may include the steps of: (1) allowing the reservoir to flow, (2) measuring the temperatures at points along the sandface, (3) passing those temperature measurements to a modeling package (program) that can distinguish between the thermodynamic properties of CH₄ to CO₂, and (4) deriving estimated ratios of CH₄ to CO₂ along the sandface using the modeling program. The modeling program may also provide flow profiles along the sandface, as in traditional distributed temperature sensing (DTS) monitoring. In addition, the program may take into account the thermodynamic components from the warming of the gases, as they flow to the surface.

[0029] Alternatively, ratios of mixed fluids may be determined by taking advantage of the changes in thermodynamic properties over time as the wellbore pressure changes (e.g., in a drawdown) and/or as the gases warm up when returning to the surface. The thermodynamic properties, such as the Joule-Thomson coefficients, of the mixed fluids may be measured. Once the estimated Joule-Thomson coefficients of the mixed fluids are obtained, the ratios of those fluids may be determined based on the standard mixing laws and the Joule-Thomson coefficients of the individual fluids.

[0030] To obtain measurements needed to estimate the CO₂ – CH₄ conversion or the ratios of these two components in the produced fluids, wells may be completed with sensors installed in the well in the production zones and along the length of the wells. Various methods for installing various sensors (e.g., temperature and pressure sensors) in the wells are known in the art. Any of such methods may be used with embodiments of the invention.

[0031] For example, U.S. Patent Application Publication No. 20080201080, “Method and Apparatus to Derive Flow Properties Within a Wellbore” by J. Lovell, et al discloses the positioning of temperature sensors along the sandface to optimize their ability to measure Joule-Thomson components. U.S. Patent Application Publication No. 2009/0182509, by Kimminau et al., entitled “Combining Reservoir Modeling with Downhole Sensors and Inductive Coupling,” discloses methods for determining flow properties by using digital sensors on the sandface, together with reservoir modeling software.

[0032] FIG. 2 shows an example of a well system for determining gas ratios and measuring flow profiles in accordance with one embodiment of the invention. As shown, a well **21** may be drilled into a layer of permafrost **23** above the surface of earth **28**. The natural gas hydrates, such as CH₄ hydrates, may be located under the permafrost **23** in a reservoir **27**. The well **21** may be completed with a lower completion hardware **100**, which may allow for injection of liquid CO₂ and subsequent production of CO₂ and CH₄ back to the surface **25**. Parameters, such as temperatures and pressures, along a sandface or sandscreen **29** may be measured and subsequently transmitted to a data analysis location **102**.

[0033] In some cases, a well **21** may be completed in one or more stages. When completed in multiple sections, the sensors may communicate across section boundaries via inductive couplers. *See e.g.*, U.S. Patent Application Publication No. 2007/0227727, by Patel et al.

[0034] If the well is dual-stage or multi-stage completions, suitable wet-mates connectors may be used to connect these various stages. For example, if a well is dual stage and the measurements are made by using pumped optical fibers, then a pumpable cable wet-mate, may be used for the connections between the stages, as disclosed, for example, in U.S. Patent No. 7,640,977, "System and method for connecting multiple stage completions," by J. Jonas. If the optical measurements are made using permanent cables in a dual stage completion, then optical wet-mates (e.g., SeaopticTM Downhole Wet Mateable Fibre Optic Connectors from Diamould, Cumbria, England) may be used. If digital measurements are made, these measurements may be made with wireless sensors powered by downhole batteries or downhole PDC control lines.

[0035] In addition, in a well with a dual stage completion, inductive couplers may be used to power a sandface array of digital temperature measurement and quartz pressure/temperature (P/T) gauges **22** provided at the bottom of the well, and P/T gauges **24** at the upper completion. The sensors, such as distributed temperature sensors **26**, may be located outside the lower completion (e.g. in cement, outside of a casing) or inside the lower completion (e.g. on a stinger or clamped to the exterior of a sandscreen **29**). Some of the downhole components may be retrievable, e.g. a downhole pump.

[0036] The temperature measurements may be optical measurements or a series of digital point measurements, such as platinum RTDs (resistance temperature detectors). Examples of optical measurements, for example, may be found in U.S. Patent No. 6,618,677, issued to Brown. RTDs are available from various commercial suppliers, for example, Omega Engineering, Inc. (Stamford, CT).

[0037] The downhole data may be transmitted to the surface using various wellbore communication techniques. The downhole data may be combined with surface measurements, such as flow-rates and average chemical compositions. The merged data can be subsequently transmitted to a reservoir modeling software program for interpretation of the ratios of CO₂ to CH₄ and for providing flow profiles along the reservoir.

[0038] While FIG. 2 illustrates one completion design, one skilled in the art would appreciate that embodiments of this invention may be applied to a variety of alternative completion designs.

[0039] Some embodiments of the invention may use passive temperature sensors, such as resistive-temperature-devices (RTDs). These devices may be mounted on a screen on the sandface. The screen may have flowing and non-flowing sections. The sensors may be deployed inside or exterior to a completion stage. The completion stage may include a fracturing operation, in which case the sensors can be positioned so as to avoid penetration or damage by the fracturing apparatus. The sensors can be permanently positioned in the casing, or alternatively they can be deployed in a temporary assembly. An example of the latter scenario is to deploy a fiber optic line inside coiled tubing, as disclosed in U.S. Patent No. 7,617,873, "System and methods using fiber optics in coiled tubing," by J. Lovell et al.

[0040] The temperature sensors are governed by the equations of conservation of mass, or momentum and mass. For traditional DTS operations, temperature differences of many degrees Centigrade may be observed. During CO₂-CH₄ operations, temperature

measurements may fluctuate by less than 1 degree C. This requires that the sensor apparatus have a high resolution and low drift, both of which are properties of platinum RTD's. A corresponding requirement is that the system of equations to be solved should be able to identify these anomalies. The Navier-Stokes formulation in the wellbore is one such system of equations that can be used, although those skilled in the art will recognize that other algorithms may also be used. Therefore, the choice of wellbore algorithm should not be viewed as a limitation of the invention.

[0041] Because the CO₂ and CH₄ fluids are compressible, a constant density formulation cannot be assumed. Instead, the fluids in the wellbore should satisfy:

$$\mathbf{u} \frac{\partial \rho}{\partial r} + \mathbf{w} \frac{\partial \rho}{\partial z} + \rho \operatorname{div} = 0, \text{ where } \operatorname{div} = \frac{1}{r} \frac{\partial(r u)}{\partial r} + \frac{\partial w}{\partial z}, \text{ where } \rho \text{ is the fluid density, } u$$

the radial velocity and w the axial velocity, where Favre averages have been taken over time to take into account turbulence.

[0042] Across interfaces, such as where the gas enters or leaves the wellbore, mass conservation becomes a statement of continuity of ρu in the direction perpendicular to that interface. The system of equations should also conserve momentum. For turbulent fluid flow that momentum conservation is well represented by the Reynolds Averaged Navier-Stokes equation. One can make the assumption that the fluids are isotropic Newtonian. Thus, in the wellbore,

$$\rho u \frac{\partial u}{\partial r} + \rho w \frac{\partial u}{\partial z} = -\frac{\partial p}{\partial r} + \frac{1}{r} \frac{\partial(r \tau_{rr})}{\partial r} + \frac{\partial \tau_{rz}}{\partial z} - \frac{\tau_{\phi\phi}}{r}$$

$$\rho u \frac{\partial w}{\partial r} + \rho w \frac{\partial w}{\partial z} = -\frac{\partial p}{\partial z} + \frac{1}{r} \frac{\partial(r \tau_{rz})}{\partial r} + \frac{\partial \tau_{zz}}{\partial z}$$

With apparent shear stresses:

$$\tau_{rr} = (\mu + \rho\epsilon_M) \left(2 \frac{\partial u}{\partial r} - \frac{2}{3} \text{div} \right)$$

$$\tau_{zz} = (\mu + \rho\epsilon_M) \left(2 \frac{\partial w}{\partial z} - \frac{2}{3} \text{div} \right)$$

$$\tau_{\phi\phi} = (\mu + \rho\epsilon_M) \left(\frac{2u}{r} - \frac{2}{3} \text{div} \right)$$

$$\tau_{rz} = (\mu + \rho\epsilon_M) \left(\frac{\partial u}{\partial r} + \frac{\partial w}{\partial z} \right)$$

wherein μ is viscosity and ϵ_M is the eddy diffusivity of momentum.

[0043] In a reservoir surrounding the rock, the momentum of a gas is well covered by the Darcy-Forcheimer equations:

$$\frac{\mu}{K} u + F\rho u \sqrt{u^2 + w^2} + \frac{\partial p}{\partial r} = 0$$

$$\frac{\mu}{K} w + F\rho w \sqrt{u^2 + w^2} + \frac{\partial p}{\partial z} = 0$$

where K is permeability, F is the Forcheimer factor, and gravity effects are ignored.

[0044] There remains the need to define energy conservation, in the wellbore

$$\rho C_p \left(u \frac{\partial T}{\partial r} + w \frac{\partial T}{\partial z} \right) = \frac{1}{r} \frac{\partial}{\partial r} \left(\lambda r \frac{\partial T}{\partial r} \right) + \frac{\partial}{\partial z} \left(\lambda \frac{\partial T}{\partial z} \right) + \beta T \left(u \frac{\partial p}{\partial r} + w \frac{\partial p}{\partial z} \right) + \Phi$$

where Φ is the energy dissipated by friction, β is thermal expansion, C_p is heat capacity and λ includes a turbulent term $\lambda = k + \frac{\epsilon_M}{Pr_T}$, where k is the thermal conductivity and Pr_T is the turbulent Prandtl number. For CO₂-CH₄ analysis, this dissipation factor is not important in the wellbore, although an optimal configuration does

take that factor into account in the reservoir, where $\Phi = u \frac{\partial p}{\partial r} + w \frac{\partial p}{\partial z}$ was found to give good results. Conversely, in the wellbore it was found optimal to consider a turbulent component to the temperature conduction but not in the porous medium, where instead k can be set equal to the average conductivities of matrix and fluid, with the weighting given by porosity. The equation for the porous medium becomes

$$\rho_f C_{pf} \left(u \frac{\partial T}{\partial r} + w \frac{\partial T}{\partial z} \right) = \frac{1}{r} \frac{\partial}{\partial r} \left(kr \frac{\partial T}{\partial r} \right) + \frac{\partial}{\partial z} \left(k \frac{\partial T}{\partial z} \right) + (\beta T - 1) \left(u \frac{\partial p}{\partial r} + w \frac{\partial p}{\partial z} \right)$$

Further background into these equations can be found, for example, in “Coupling of Darcy-Forcheimer and compressible Navier-Stokes equations with Heat Transfer,” by M. Amara, et al, SIAM Journal of Scientific Computing, 2008.

[0045] These equations can be solved as a separate standalone program (finite element or finite difference) or can be combined into existing reservoir simulators. Turbulence terms are reviewed in detail in standard textbooks on heat transfer, e.g., “Convective Heat and Mass Transfer,” by W. Kays, M. Crawford, B. Weigand, McGraw-Hill, 2005.

[0046] For insight into the porous media equation, one can note that the conductivity terms are much less than the other terms in the equation so that

$$\rho_f C_{pf} \left(u \frac{\partial T}{\partial r} + w \frac{\partial T}{\partial z} \right) \approx (\beta T - 1) \left(u \frac{\partial p}{\partial r} + w \frac{\partial p}{\partial z} \right)$$

and hence $\rho_f C_{pf} \Delta T \approx (\beta T - 1) \Delta p$.

[0047] The ratio $\frac{\Delta T}{\Delta p} \approx \frac{\beta T - 1}{\rho_f C_{pf}}$ is called the Joule-Thomson effect and is an empirically

derived thermodynamic property. It typically varies with both pressure and temperature,

as do the density, compressibility and viscosity terms. The thermodynamic properties of CO₂ and CH₄ under various conditions can be found in technical handbooks or from the National Institute of Standards and Technology (NIST) website: <http://webbook.nist.gov/chemistry/fluid/>.

[0048] Analysis of those values shows that the Joule-Thomson coefficients of CO₂ and CH₄ are substantially different. For example, if the wellbore is at 300 psia and the temperature varies from -20 °C to 20 °C, then the Joule-Thomson coefficient of CH₄ varies from 0.07 °F/psia to 0.05 °F/psia. Under the similar pressure, CO₂ is a liquid below -18.402 °C with a Joule Thomson coefficient ~ 0.001 °F/psia, and above -18.402 °C, the Joule-Thomson coefficient of gaseous CO₂ increases to 0.21 °F/psia, followed by a slow decrease to 0.143 °F/psia at 20 °C.

[0049] Among various thermodynamic properties, the Joule-Thomson coefficients of CO₂ and CH₄ are particularly useful because these coefficients are substantially different under most conditions seen during CO₂-CH₄ sequestration.

[0050] Joule-Thomson analysis has previously been used to differentiate between oil and water, as detailed, for example, in U.S. Patent Application Publication No. 2010/0163223, "Method for Determining Reservoir Properties in a Flowing Well", by G. Brown.

[0051] The different Joule-Thomson coefficients make it feasible to estimate the ratios of these CO₂ and CH₄ components in a mixed fluid (liquid or gas). Once the ratios of CO₂ and CH₄ are determined, this parameter may be used to monitor the conversion from methane hydrate to CO₂ hydrate or to monitor the production fluids as they flow uphole.

- [0052]** Embodiments of this invention may also include reservoir modeling programs that incorporate knowledge of the thermodynamic properties of CO₂ and CH₄ as functions of temperature and pressure.
- [0053]** Similarly, thermodynamic properties of water may be obtained for monitoring water productions from the formation. The following description will use CH₄ and CO₂ as examples of how to monitor the production of a mixed fluid and how to monitor the ratios of the produced fluids. However, one skilled in the art would appreciate that the same methods may be applied to monitor other fluids (e.g., water). As noted above, monitoring water production from the formation is critical in order to prevent ice formation that would clog the production tubing.
- [0054]** Joule-Thomson effects predicts that the temperatures measured by the sensors will vary with pressure changes (e.g., in a drawdown). The equation, $\Delta T = C_{JT} \times \Delta P$, correlates temperature changes with the pressure changes and Joule-Thomson coefficient (C_{JT}). Because the Joule-Thomson coefficients of CH₄ and CO₂ are different, it is possible to monitor the Joule-Thomson effects as a function of pressure changes (e.g., in a drawdown) to identify the types of gases and ratios thereof produced along the sandface. A typical drawdown may produce 10 psi pressure drop, which will produce a measurable difference in temperature between CO₂ and CH₄. In addition, there will be a large change in the measured temperatures, if liquid CO₂ is produced versus gaseous CO₂.
- [0055]** For example, a producing well may have certain flow profiles in the wellbore. When the wellhead pressure is reduced by say 50 psi, the pressure reduction will lead to

corresponding changes in the drawdown across each sensor, thereby producing changes in the measured temperatures. The temperature changes can be used in a modeling program to derive an indication of the Joule-Thomson coefficients. In addition to temperature measurements, quartz pressure gauges may be added to the downhole hardware to provide pressure measurements, which can be used to help stabilize the inversion. In accordance with embodiments of the invention, at least two pressure gauges are preferably included in the wellbore for pressure measurements.

[0056] As noted above, embodiments of the invention relate to methods for monitoring the CO₂ and CH₄ conversion and for monitoring the compositions of the produced fluids from methane hydrate conversion. Methods of the invention are based on a plurality of temperature measurements obtained under different conditions. The plurality of temperature measurements are used in a modeling program, which makes use of differing thermodynamic properties of components in a mixed fluids to decipher the compositions of the mixed fluids. The temperature measurements for use with embodiments of the invention may be obtained under various conditions, such as in different locations in the wellbore, after pressure changes in the wellbore, or after changes in CO₂ injection.

[0057] FIG. 3 shows an exemplary method for monitoring the CO₂ and CH₄ conversion in a reservoir in accordance with one embodiment of the invention. The method **300** may include completing a well with one or more sensors for temperature measurements (Step **301**). The method may not include the well completion step if performed with an existing (complete) well. The sensors may also include sensors for measuring pressures and other well or fluid properties, such as flow rates, fluid density, fluid viscosity, fluid resistivity,

etc. Using the sensors, temperatures along sections of the completion are measured, as liquid CO₂ is being injected into a wellbore (step **302**). The temperature measurements may be made with optical sensors, digital sensors, etc. In addition, other well and fluid properties (e.g., pressure) may be measured.

[0058] Then, allow the wellbore to warm up while monitoring the temperature changes (step **303**). The well may be allowed to warm up by slowing or stopping the injection of liquid CO₂. Again, other data (e.g., pressure) may be measured together with the temperature data. The temperature data obtained in steps **302** and **303**, together with other optional data (such as pressure data) may be used to make inferences regarding the conversion of CH₄ hydrate to CO₂ hydrate and the radial penetration of the liquid CO₂ using a modeling program (step **304**).

[0059] Some methods of the invention relate to using temperature (and optionally pressure) measurements performed at post-injection of liquid CO₂ to determine the ratios of CH₄ to CO₂ in the produced fluids. For example, FIG. 4 shows a method **400** in accordance with one embodiment of the invention that includes the steps of: allowing the reservoir to flow (step **401**); and measuring the temperatures at points along the sandface while the fluids are flowing (step **402**). In addition, other parameters (e.g., pressure) may be measured to help stabilize the inversion.

[0060] The temperature measurements are then passed to a modeling package (program) that can distinguish between the thermodynamic properties of CH₄ to CO₂ to derive estimated ratios of CH₄ to CO₂ along the sandface using the modeling program (step **403**). The modeling program may also provide flow profiles along the sandface, as in

traditional distributed temperature sensing (DTS) monitoring. In addition, the program may take into account the thermodynamic components from the warming of the gases, as they flow to the surface.

[0061] According to some methods of the invention, ratios of mixed fluids may be determined by taking advantage of the changes in thermodynamic properties over time as the wellbore pressure changes (e.g., in a drawdown) and/or as the gases warm up when returning to the surface. For example, FIG. 5 shows a method **500** for determining fluid ratios based on changes in thermodynamic properties. First, a thermodynamic property (such as the Joule-Thomson coefficients) of the mixed fluids is determined, either over time as the well pressure changes or as the fluid temperature changes (step **501**). Once the thermodynamic parameters (e.g., Joule-Thomson coefficient) of the mixed fluids are determined, the ratios of different components in the fluids may be determined based on the standard mixing laws and the parameters (e.g., Joule-Thomson coefficients) of the individual fluids (step **502**).

[0062] Advantages of embodiments of the invention may include one or more of the following. Systems and methods of the invention may improve monitoring the conversion of CH₄ hydrate to CO₂ hydrate in a reservoir, the ratios of the produced CH₄ and CO₂, and the production of any other fluids (such as water). With the ability to monitor these parameters, efficient and safe conversion of abundant methane hydrates would become economically feasible. In addition, CO₂ can be sequestered, while CH₄ is produced.

[0063] While the invention has been described with respect to a limited number of embodiments, those skilled in the art, having benefit of this disclosure, will appreciate that other embodiments can be devised which do not depart from the scope of the invention as disclosed herein. Accordingly, the scope of the invention should be limited only by the attached claims.

CLAIMS

1. A method for monitoring production from a methane hydrate reservoir, comprising:
obtaining a plurality of temperature measurements in a wellbore connected with
the methane hydrate reservoir; and
deriving a parameter relating to conversion of methane hydrate to carbon dioxide
(CO₂) hydrate by injection of liquid CO₂, wherein the deriving uses a
modeling program and the plurality of temperature measurements,
wherein the modeling program uses at least one parameter relating to a
thermodynamic properties that are substantially different between methane
and CO₂.
2. The method of claim 1, wherein the plurality of temperature measurements comprises:
a first set of temperature measurements obtained in a wellbore while injecting
liquid CO₂ into the wellbore; and
a second set of temperature measurements obtained in the wellbore while
allowing the wellbore to warm up.
3. The method of claim 2, the allowing the wellbore to warm up involves slowing or
stopping the injecting of liquid CO₂.
4. The method of claim 1, wherein the at least one parameter relating to thermodynamic
properties comprises Joule-Thomson coefficients of methane and CO₂.
5. The method of claim 1, wherein the parameter relating to the conversion of methane
hydrate to CO₂ hydrate is a ratio of methane and CO₂ in a mixed fluid.

6. The method of claim 1, further comprising estimating an extent of radial penetration of the injected liquid CO₂.
7. The method of claim 1, wherein the plurality of temperature measurements are obtained at different depths in the wellbore while a produced mixed fluid flows uphole.
8. The method of claim 1, wherein the plurality of temperature measurements are obtained after a change in pressure in the wellbore.
9. The method of claim 8, wherein the deriving comprises:
 - determining an apparent Joule-Thomson coefficient of a produced mixed fluid, based on a relationship between the pressure change and changes in the plurality of temperature measurements; and
 - deriving, based on a standard mixing law, a ratio of methane and CO₂ in the produced mixed fluid, using the apparent Joule-Thomson coefficient of the produced mixed fluid and individual Joule-Thomson coefficients of methane and CO₂.
10. The method of claim 8, wherein the pressure change is produced by a change in production rate.
11. The method of claim 8, wherein the deriving is based on $\Delta T = C_{JT} \times \Delta P$, wherein ΔT is temperature change, C_{JT} is Joule-Thomson coefficient, and ΔP is pressure change.
12. A system for monitoring production from a methane hydrate reservoir, comprising:

a temperature sensing system for measuring temperature in a well connected with the methane hydrate reservoir; and

a processor having a program for determining, based on temperatures measured by the temperature sensing system, a ratio of components in a mixed fluid, wherein the program makes use of a thermodynamic property of individual components in the mixed fluid.

13. The system of claim 12, wherein the temperature sensing system comprises an optical sensor, a resistive-temperature sensor, or a passive temperature sensor.
14. The system of claim 12, wherein the thermodynamic property comprise Joule-Thomson coefficient.
15. A system for monitoring production from a methane hydrate reservoir comprising a processor and a memory storing a program having instructions for:
 - deriving a parameter relating to conversion of methane hydrate to carbon dioxide (CO₂) hydrate by injection of liquid CO₂,
 - wherein the deriving uses a modeling program and a plurality of temperature measurements obtained in a wellbore connected with the methane hydrate reservoir, and
 - wherein the modeling program uses at least one parameter relating to a thermodynamic properties that are substantially different between methane and CO₂.

78543-326

16. The system of claim 15, wherein the at least one parameter relating to thermodynamic properties comprises Joule-Thomson coefficients of methane and CO₂.
17. The system of claim 15, wherein the parameter relating to the conversion of methane hydrate to CO₂ hydrate is a ratio of methane and CO₂ in a mixed fluid.
18. The system of claim 15, the program further comprising instructions for estimating an extent of radial penetration of the injected liquid CO₂.

FIG. 1
(Prior Art)

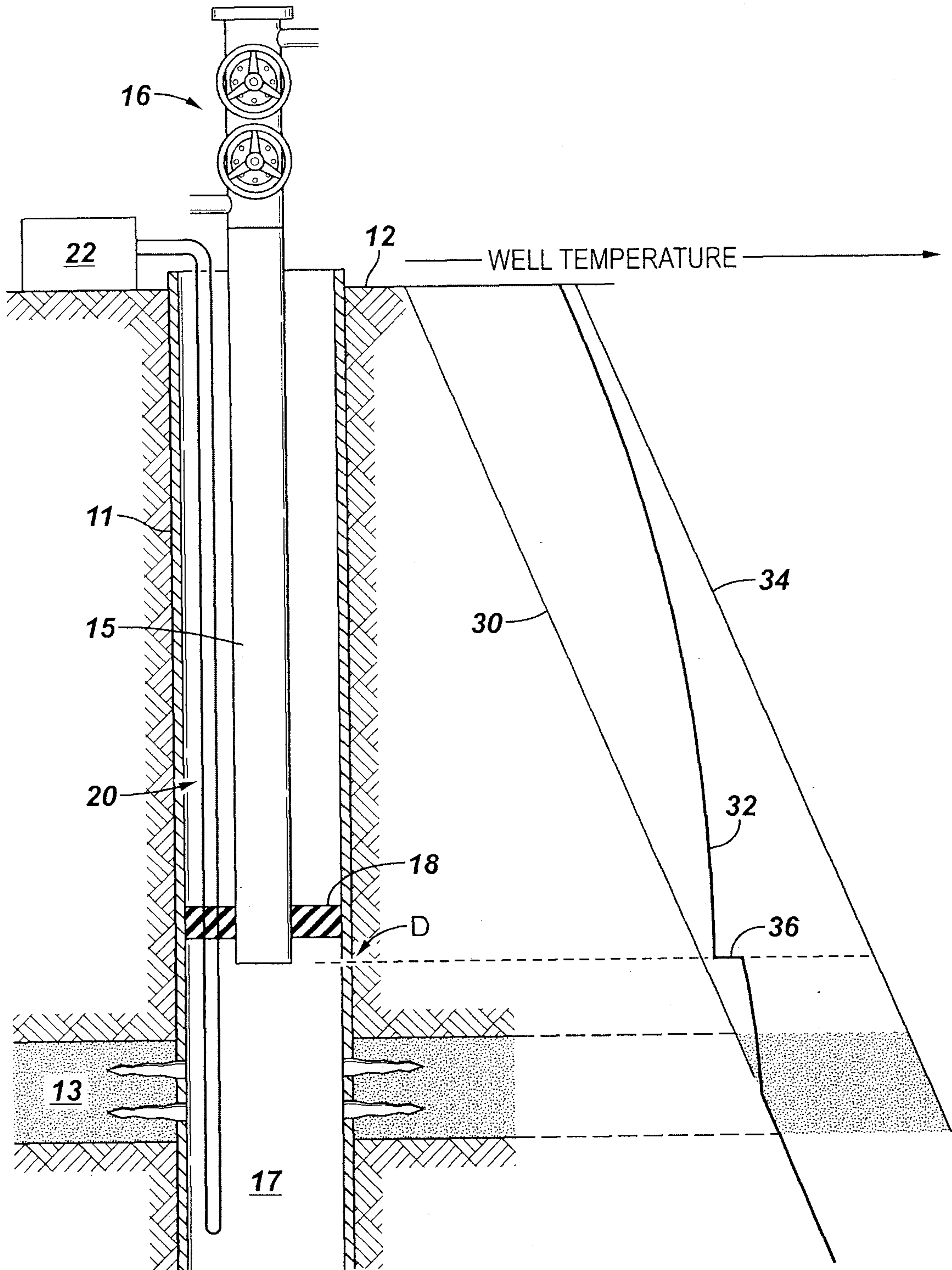

3/3

