



(51) International Patent Classification:

H02G 3/10 (2006.01) *H05K 5/03* (2006.01)
H01H 9/04 (2006.01) *A47G 29/12* (2006.01)
H05K 5/02 (2006.01) *A47G 29/00* (2006.01)

(21) International Application Number:

PCT/US2016/037854

(22) International Filing Date:

16 June 2016 (16.06.2016)

(25) Filing Language:

English

(26) Publication Language:

English

(30) Priority Data:

62/181,966 19 June 2015 (19.06.2015) US

(71) Applicant: **HUBBELL INCORPORATED** [US/US]; 40 Waterview Drive, Shelton, CT 06484-1000 (US).

(72) Inventors: **DRECHSLER, Dale, Alan**; 14 Wangum Road, Westbrook, CT 06498 (US). **MCALEER, Gregory, Bryant**; 839 Fairfield Beach Road, Fairfield, CT 06824 (US). **HOGESTYN, Bart, Richard**; 11 Newgate Road, Oxford, CT 06478 (US). **SCHANZILLO, Thomas, Louis**; 87 Sentry Hill Road, Monroe, CT 06468 (US).

(74) Agent: **MCMAHON, Edward, L.**; Ohlandt, Greeley, Ruggiero & Perle, LLP, One Landmark Square, Tenth Floor, Stamford, CT 06901-2682 (US).

(81) Designated States (unless otherwise indicated, for every kind of national protection available):

AE, AG, AL, AM, AO, AT, AU, AZ, BA, BB, BG, BH, BN, BR, BW, BY, BZ, CA, CH, CL, CN, CO, CR, CU, CZ, DE, DK, DM, DO, DZ, EC, EE, EG, ES, FI, GB, GD, GE, GH, GM, GT, HN, HR, HU, ID, IL, IN, IR, IS, JP, KE, KG, KN, KP, KR, KZ, LA, LC, LK, LR, LS, LU, LY, MA, MD, ME, MG, MK, MN, MW, MX, MY, MZ, NA, NG, NI, NO, NZ, OM, PA, PE, PG, PH, PL, PT, QA, RO, RS, RU, RW, SA, SC, SD, SE, SG, SK, SL, SM, ST, SV, SY, TH, TJ, TM, TN, TR, TT, TZ, UA, UG, US, UZ, VC, VN, ZA, ZM, ZW.

(84) Designated States (unless otherwise indicated, for every kind of regional protection available):

ARIPO (BW, GH, GM, KE, LR, LS, MW, MZ, NA, RW, SD, SL, ST, SZ, TZ, UG, ZM, ZW), Eurasian (AM, AZ, BY, KG, KZ, RU, TJ, TM), European (AL, AT, BE, BG, CH, CY, CZ, DE, DK, EE, ES, FI, FR, GB, GR, HR, HU, IE, IS, IT, LT, LU, LV, MC, MK, MT, NL, NO, PL, PT, RO, RS, SE, SI, SK, SM, TR), OAPI (BF, BJ, CF, CG, CI, CM, GA, GN, GQ, GW, KM, ML, MR, NE, SN, TD, TG).

Declarations under Rule 4.17:

— of inventorship (Rule 4.17(iv))

Published:

— with international search report (Art. 21(3))

(54) Title: ENCLOSURES HAVING SLOPING AND CONVEX CURVED TOPS

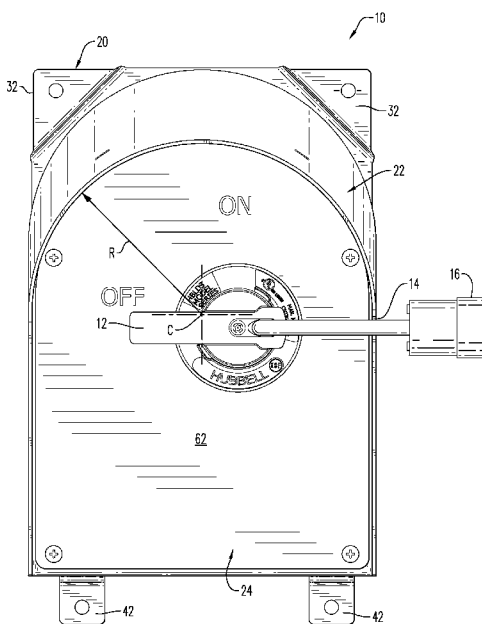

FIG. 1

(57) Abstract: An enclosure is provided that includes a main housing, a top housing, and a front housing. The main housing defines at least a rear wall of the enclosure, the top housing defines a top wall and a pair of side walls of the enclosure, and the front housing defines a front wall of the enclosure. The top wall has a convex curved portion that spans between side walls, where the convex curved portion has an angle that slopes downward from the rear wall towards the front wall.

WO 2016/205500 A1

ENCLOSURES HAVING SLOPING AND CONVEX CURVED TOPS

BACKGROUND

1. Field of the Invention

[0001] The present disclosure is related to enclosures. More particularly, the present disclosure is related to enclosures having sloping and convex curved tops.

2. Description of Related Art

[0002] Enclosures for protecting and/or mounting sensitive or fragile devices such as electrical devices, communication devices, pneumatic devices, and other devices are known. In many instances, the enclosures are used in environments where cleanliness is of primary importance – meaning that the enclosure is exposed to frequent cleaning activities that include water and/or other cleaning agents.

[0003] Thus, it has been determined by the present disclosure that there is a continuing need for enclosures that provide for protection and/or mounting of sensitive or fragile devices in demanding environments.

[0004] Accordingly, it has been determined by the present disclosure that there is a continuing need for enclosures that overcome, alleviate, and/or mitigate one or more of the aforementioned and other deleterious effects of prior art enclosures.

SUMMARY

[0005] An enclosure is provided that includes a main housing, a top housing, and a front housing. The main housing defines at least a rear wall of the enclosure, the top housing defines a top wall and a pair of side walls of the enclosure, and the front housing defines a front wall of the enclosure. The top wall has a convex curved

portion that spans between side walls, where the convex curved portion has an angle that slopes downward from the rear wall towards the front wall.

[0006] In embodiments alone or in combination with one or more of the aft mentioned embodiments, the top and side walls of the top housing further include an overhang, which extends forward of the front wall.

[0007] In embodiments alone or in combination with one or more of the aft mentioned embodiments, the rear wall further includes one or more main mounts, which are configured to secure the enclosure to a support structure with a standoff between the rear wall and the support structure.

[0008] In embodiments alone or in combination with one or more of the aft mentioned embodiments, the one or more main mounts each have a downwardly sloping shoulder that acts as a guide channel to prevent the collection of water or debris.

[0009] In embodiments alone or in combination with one or more of the aft mentioned embodiments, the downwardly sloping shoulder slopes toward an outer edge of the rear wall.

[0010] In embodiments alone or in combination with one or more of the aft mentioned embodiments, the one or more main mounts are stamped in the rear wall.

[0011] In embodiments alone or in combination with one or more of the aft mentioned embodiments, the main housing further includes one or more supplemental mounts, which are configured to assist the one or more main mounts in securing the enclosure to the support structure with the standoff between the rear wall and the support structure.

[0012] In embodiments alone or in combination with one or more of the aft mentioned embodiments, the one or more supplemental mounts further includes a shoulder that slopes at least away from the rear wall.

[0013] The above-described and other features and advantages of the present disclosure will be appreciated and understood by those skilled in the art from the following detailed description, drawings, and appended claims.

BRIEF DESCRIPTION OF THE DRAWINGS

[0014] FIG. 1 is a front view of an exemplary embodiment of an enclosure according to the present disclosure, shown in a locked state;

[0015] FIG. 2 is a front, top perspective view of the enclosure of FIG. 1, shown in an unlocked state;

[0016] FIG. 3 is a rear, top perspective view of the enclosure of FIG. 2;

[0017] FIG. 4 is a side view of the enclosure of FIG. 2;

[0018] FIG. 5 is an exploded view of the enclosure of FIG. 2;

[0019] FIG. 6 is an exploded view of the main housing of FIG. 5; and

[0020] FIG. 7 is a front, top perspective view of the enclosure of FIG. 1, shown with alternate exemplary embodiments of a front housing and a side housing.

DETAILED DESCRIPTION

[0021] Referring to the drawings and in particular to FIGS. 1-3, an exemplary embodiment of an enclosure according to the present disclosure is shown and is generally referred to by reference numeral 10. Enclosure 10 is configured to protect

and mount one or more devices 12, illustrated by way of example as a rotary switch, to a support structure (i.e., wall, machine, etc.).

[0022] Advantageously, enclosure 10 is configured for use in environments where sanitary conditions are maintained through routine wash and/or hose downs such as commercial kitchens, restaurants, food manufacturing facilities, medical device manufacturing facilities, semiconductor manufacturing facilities, drug or chemical manufacturing facilities, and others. Thus, device 10 to shield device 12 from contact with the operator, debris, and, in some instances, liquid such as water – while providing easily to clean surfaces and surfaces that shed water and debris, allows cleaning of the space behind the enclosure, and prevent spaces that allow the growth and/or harboring of contaminants such as, but not limited to, bacteria, viruses, mold, and others.

[0023] Generally and as is described in more detail below, enclosure 10 has a downward sloping and convex curved top that prevents or at least mitigates any standing liquids or other matter that can accumulate and lead to grow and/or harboring of contaminants.

[0024] Accordingly, in some embodiments either alone or in combination with one or more of the aft mentioned standards, enclosure 10 is configured to be suitable for protection from at least light splashes of liquid, namely to be rated Type 2 by the National Electrical Manufacturing Association (NEMA). Of course, it is contemplated by the present disclosure for enclosure 10 to be configured for protection from splashes (e.g., NEMA - Type 4 and/or 4X), from temporary submersion (e.g., NEMA - Type 6), from permanent submersion (e.g., NEMA - Type 6P), from oil seepage (e.g., NEMA - Type 12 and/or 12K), from oil splashes (e.g., NEMA - Type 13), and any combinations thereof.

[0025] In other embodiments either alone or in combination with one or more of the afore and/or aft mentioned standards, enclosure 10 is configured to meet or exceed the requirements under the International Protection Marking code (IP Code)

for at least solid and liquid ingress protection. In one particularly embodiment, enclosure 10 has an IP Code rating of IP69k. Of course, it is contemplated for enclosure 10 to have any desired level of protection under the IP Code against ingress of solid objects and/or liquids.

[0026] For example, it is contemplated by the present disclosure for enclosure 10 to be sufficient to have a level of protection under the IP Code for solid objects (indicated by the first digit in the IP Code) including, but not limited to, Level 1, which protects against ingress of objects having a size of greater than 50 mm; Level 2, which protects against ingress of objects having a size of greater than 12.5 mm; Level 3, which protects against ingress of objects having a size of greater than 2.5 mm; Level 4, which protects against ingress of objects having a size of greater than 1 mm; Level 5, which protects against ingress of dust protected; or Level 6, which is dust tight.

[0027] Further, it is contemplated by the present disclosure for enclosure 10 to be sufficient to have a level of protection under the IP Code for liquids (indicated by the second digit in the IP Code) including, but not limited to, Level 1, which protects against dripping water; Level 2, which protects against ingress of Dripping water when tilted up to 15°; Level 3, which protects against ingress of Spraying water; Level 4, which protects against ingress of Splashing of water; Level 5, which protects against ingress of Water jets; Level 6, which protects against ingress of Powerful water jets; Level 6K, which protects against ingress of Powerful water jets with increased pressure; Level 7, which protects against immersion in water up to 1 m; Level 8, which protects against immersion in water beyond 1;and Level 9K, which protects against ingress of powerful high temperature water jets.

[0028] In other embodiments either alone or in combination with one or more of the afore and/or aft mentioned standards, enclosure 10 is configured to meet or exceed the requirements under the National Sanitation Foundation (NSF) Standard 51 for Food Equipment Materials.

[0029] Additionally, enclosure 10 – when used with an electrical control device such as a switch – is further configured to meet lock out requirements such as those required by the Occupational Safety and Health Administration (OSHA). Specifically, enclosure 10 includes a locking feature 14, which allows the user to secure device 12 in a desired position (e.g., de-energized) with a lock 16 or other device.

[0030] Enclosure 10 is described in more detail with simultaneous reference to FIGS. 2-6. Enclosure 10 has a main housing 20, a top housing 22, and a front housing 24.

[0031] Main housing 20 defines a rear wall 26, a bottom wall 28, and a front mount region 30. Rear wall 26 includes one or more main mounts 32, which are configured to secure enclosure 10 to a support structure (not shown) with a desired gap or standoff between the rear wall and the support structure. Additionally, main mounts 32 include downwardly sloping shoulder 34 that acts as a guide channel to prevent the collection of water or debris on enclosure 10. In the illustrated embodiment, shoulder 34 slopes toward an outer edge 36 of rear wall 26, so as to prevent the water or debris from being guided between the rear wall and the support structure. Of course, it is contemplated by the present disclosure for shoulder 34 to slope away from outer edge 36 or in one or more desired directions.

[0032] In the illustrated embodiment, main housing 20 is formed as a single member of a stamped metal. Of course, other configurations of main housing 20 are contemplated by the present disclosure.

[0033] Main housing 20 can also include one or more supplemental mounts 42, which are configured to assist main mounts 32 in securing enclosure 10 to the support structure with the desired gap or standoff between rear wall 26 and the support structure. Supplemental mounts 42, similar to main mounts 32 discussed above, includes a shoulder 44 that acts as a guide channel to prevent the collection of water or debris on enclosure 10. In the illustrated embodiment, shoulder 44 slopes toward the support structure and away from rear wall 26. Of course, it is contemplated by the present disclosure for shoulder 44 to slope any desired

direction – or in more than one direction - such as, but not limited to away from outer edge 36.

[0034] In the illustrated embodiment, supplemental mounts 42 are positioned in an opening 46 defined in main housing 20 – namely in rear wall 26 and/or bottom wall 28. Here, the mounts 42 can be secured to main housing 20 preferably by a weld or braze that also functions to seal opening 46.

[0035] Top housing 22 defines side walls 48, 50 and a top wall 52. Top housing 22 and main housing 20 are secured to one another in any desired method. Preferably, main and top housings 20, 22 are secured to one another by a weld or weld or braze that also functions to seal any gaps therebetween.

[0036] Advantageously, top wall 52 has an angle 54 that slopes downward from rear wall 28 towards front housing 24. Downward angle 54 is preferably less than 45 degrees, more preferably less than 30 degrees, with about 15 degrees being most preferred, and any subranges therebetween.

[0037] Furthermore, top wall 52 further includes a convex curved portion 56 that spans the area between side walls 48, 50. Curved portion 56 is preferably semi-circular with a center of curvature (C) and a radius (R).

[0038] Thus, top housing 22 has downward angle 54 in one plane, namely the plane extending from rear wall 26 to front housing 24, and has curved portion 56 in a second plane, namely the plane extending between side walls 48, 50. Simply stated, convex curved portion 56 is both curved and downwardly angled.

[0039] In this manner, enclosure 10 advantageously ensures that any liquid that is sprayed onto top housing 22 is guided away from the intersection of rear housing 20 and top housing 22 by angle 54 and off of the top housing by curved portion 56. Additionally, enclosure 10 also advantageously prevents or mitigates instances of the

enclosure being used as step or shelf, which can damage the enclosure and/or device 12 therein.

[0040] Further, top housing 22 is configured so that at least top wall 52 forms an overhang or shield 58. Preferably, top housing 22 is also configured so that side walls 48, 50 also form overhang or shield 60.

[0041] Advantageously, overhangs 58, 60 extend forward of front housing and at least a portion of electrical 12. In this manner, fluid falling off of curved portion 56 as a result of angle 54 does not land on device 12. Moreover, overhangs 58, 60 allow enclosure 10 to be sufficient, in some embodiments, to provide protection to device 12 and/or to front housing 24 against incidental impacts. Here, it is contemplated by the present disclosure for enclosure 10 to find use in industrial settings, where motorized traffic and/or the transportation of materials or goods is common such that the enclosure provides a level of protection against inadvertent impact by these and/or other traffic.

[0042] In the illustrated embodiment, top housing 22 is formed as a single member of a stamped metal. Of course, other configurations of top housing 22 are contemplated by the present disclosure.

[0043] Front housing 24 defines a front wall 62 having an opening 64 through which device 12 is accessed and/or protrudes. In some embodiments, enclosure 10 can include a gasket or other seal (not shown) to seal any gap between device 12 and front wall 62 and/or opening 64.

[0044] Advantageously, front wall 62 has a curved portion 66 that corresponds to curved portion 56 so as to close any gap between top and front housings 22, 24. Front wall 62 is removably secured to front mount region 30 of main housing 20 by one or more mechanical fasteners 68. In some embodiments, enclosure 10 can include a gasket or other seal 70 to seal any gap between front wall 62 and/or front mount region 30 and/or top housing 22. Thus, front mount region 30 has an outer

rim 38 that matches curved portions 56 66 and includes an open region 40 within the outer rim.

[0045] In the illustrated embodiment, front housing 24 is formed as a single member of a stamped metal. Of course, other configurations of front housing 24 are contemplated by the present disclosure.

[0046] Main, top, and front housings 20, 22, and 24 of enclosure 10 are described above as being made of stamped metal. Of course, it is contemplated by the present disclosure for each of the housings 20, 22, 24 to be made of any similar or dissimilar material that has the strength and clean ability sufficient to meet the requirements discussed above. In one particular embodiment, housings 20, 22, and 24 – as well as supplemental mounts 42 - are made of stamped stainless steel and/or cold rolled steel having a protective and/or corrosion resistant coating.

[0047] In embodiments, where the device 12 requires a feed line (i.e., power line, communication cable, pneumatic conduit, etc.), enclosure 10 can include an opening through one or more walls of the housing 20, 22, and 24 and a water tight insert (not shown) positioned in the opening in a manner known in the art. Preferably, enclosure 10 includes an opening 70 – in some embodiment temporarily closed by a knockout 72 - through bottom wall 28.

[0048] It should be recognized that enclosure 10 is illustrated having device 12 as a rotary switch and extending outwardly from front housing 24. Of course, it is contemplated by the present disclosure for device 12 to be any desired device that protrudes from front housing 24 or is housed completely within enclosure 10. In some embodiments, device 12 can be a device selected from the group consisting of an electrical device, a communication device, a pneumatic device, and other devices

[0049] For example, enclosure 10 is shown in FIG. 7 having an alternate exemplary embodiment of a top housing 122 and a front housing 124.

[0050] Here, front housing 124 defines a front wall 162 – that lacks the opening 64 of the embodiment of enclosure 10 shown in FIGS. 1-6. Rather, a device (not shown) is housed within enclosure 10. In this embodiments where front housing 124 lacks a device extending therefrom, top housing 122 can also lack the locking feature 14 shown in FIGS. 1-6. Rather in this embodiment, top housing 122 can includes side walls 148, 150 that provide overhang or shield 160 without the locking feature.

[0051] It should also be noted that the terms “first”, “second”, “third”, “upper”, “lower”, and the like may be used herein to modify various elements. These modifiers do not imply a spatial, sequential, or hierarchical order to the modified elements unless specifically stated.

[0052] While the present disclosure has been described with reference to one or more exemplary embodiments, it will be understood by those skilled in the art that various changes may be made and equivalents may be substituted for elements thereof without departing from the scope of the present disclosure. In addition, many modifications may be made to adapt a particular situation or material to the teachings of the disclosure without departing from the scope thereof. Therefore, it is intended that the present disclosure not be limited to the particular embodiment(s) disclosed as the best mode contemplated, but that the disclosure will include all embodiments falling within the scope of the appended claims.

REFERENCE NUMBERS:

enclosure 10
device 12
locking feature 14
lock 16
--- 18
main housing 20
top housing 22
front housing 24
rear wall 26
bottom wall 28
front mount region 30
main mounts 32
shoulder 34
outer edge 36
outer rim 38
open region 40
supplemental mounts 42
shoulder 44
opening 46
side walls 48, 50
top wall 52
angle 54
convex curved portion 56
overhangs 58, 60
center of curvature C
radius R
front wall 62
opening 64
curved portion 66
fastener 68
gasket or seal 70
opening 72
knockout 74
top housing 122
front housing 124
side walls 148, 150
overhang 160
front wall 162

CLAIMS

What is claimed is:

Claim 1. An enclosure comprising:

a main housing that defines at least a rear wall of the enclosure;

a top housing that defines a top wall and a pair of side walls of the enclosure;

and

a front housing that defines a front wall of the enclosure, the top wall having a convex curved portion that spans between the side walls, wherein the convex curved portion has an angle that slopes downward from the rear wall towards the front wall.

Claim 2. The enclosure of claim 1, wherein the top and side walls of the top housing further comprise an overhang, which extends forward of the front wall.

Claim 3. The enclosure of claim 1, wherein the rear wall further comprises one or more main mounts, which are configured to secure the enclosure to a support structure with a standoff between the rear wall and the support structure.

Claim 4. The enclosure of claim 3, wherein the one or more main mounts each have a downwardly sloping shoulder that acts as a guide channel to prevent the collection of water or debris.

Claim 5. The enclosure of claim 4, wherein the downwardly sloping shoulder slopes toward an outer edge of the rear wall.

Claim 6. The enclosure of claim 3, wherein the one or more main mounts are stamped in the rear wall.

Claim 7. The enclosure of claim 3, wherein the main housing further comprises one or more supplemental mounts, which are configured to assist the one or more

main mounts in securing the enclosure to the support structure with the standoff between the rear wall and the support structure.

Claim 8. The enclosure of claim 7, wherein the one or more supplemental mounts further comprise a shoulder that slopes at least away from the rear wall.

Claim 9. The enclosure of claim 1, wherein the front wall has an opening sufficient to receive a portion of a device therethrough.

Claim 10. An enclosure comprising:

a top housing that defines a top wall and a pair of side walls of the enclosure, the top wall having a convex curved portion that spans between the side walls;

a front housing that defines a front wall, the front wall having a curved portion that corresponds to the curved portion of the top wall so as to close any gap between the top and front housings; and

a main housing that defines a rear wall, a bottom wall, and a front mount region, the front mount region having an outer rim that matches the curved portions of the top and front housings, wherein the convex curved portion has an angle that slopes downward from the rear wall towards the front wall.

Claim 11. The enclosure of claim 10, wherein the top and side walls of the top housing further comprise an overhang, which extends forward of the front wall.

Claim 12. The enclosure of claim 10, wherein the rear wall further comprises one or more main mounts, which are configured to secure the enclosure to a support structure with a standoff between the rear wall and the support structure.

Claim 13. The enclosure of claim 12, wherein the one or more main mounts each have a downwardly sloping shoulder that acts as a guide channel to prevent the collection of water or debris.

Claim 14. The enclosure of claim 13, wherein the downwardly sloping shoulder slopes toward an outer edge of the rear wall.

Claim 15. The enclosure of claim 12, wherein the one or more main mounts are stamped in the rear wall.

Claim 16. The enclosure of claim 12, wherein the main housing further comprises one or more supplemental mounts, which are configured to assist the one or more main mounts in securing the enclosure to the support structure with the standoff between the rear wall and the support structure.

Claim 17. The enclosure of claim 16, wherein the one or more supplemental mounts further comprise a shoulder that slopes at least away from the rear wall.

Claim 18. The enclosure of claim 10, wherein the front wall is removably connected to the front mount region.

Claim 19. The enclosure of claim 18, further comprising a gasket between the front wall the front mount region.

Claim 20. The enclosure of claim 10, wherein the front wall and the front mount region further includes open regions sufficient to receive a portion of a device therethrough.

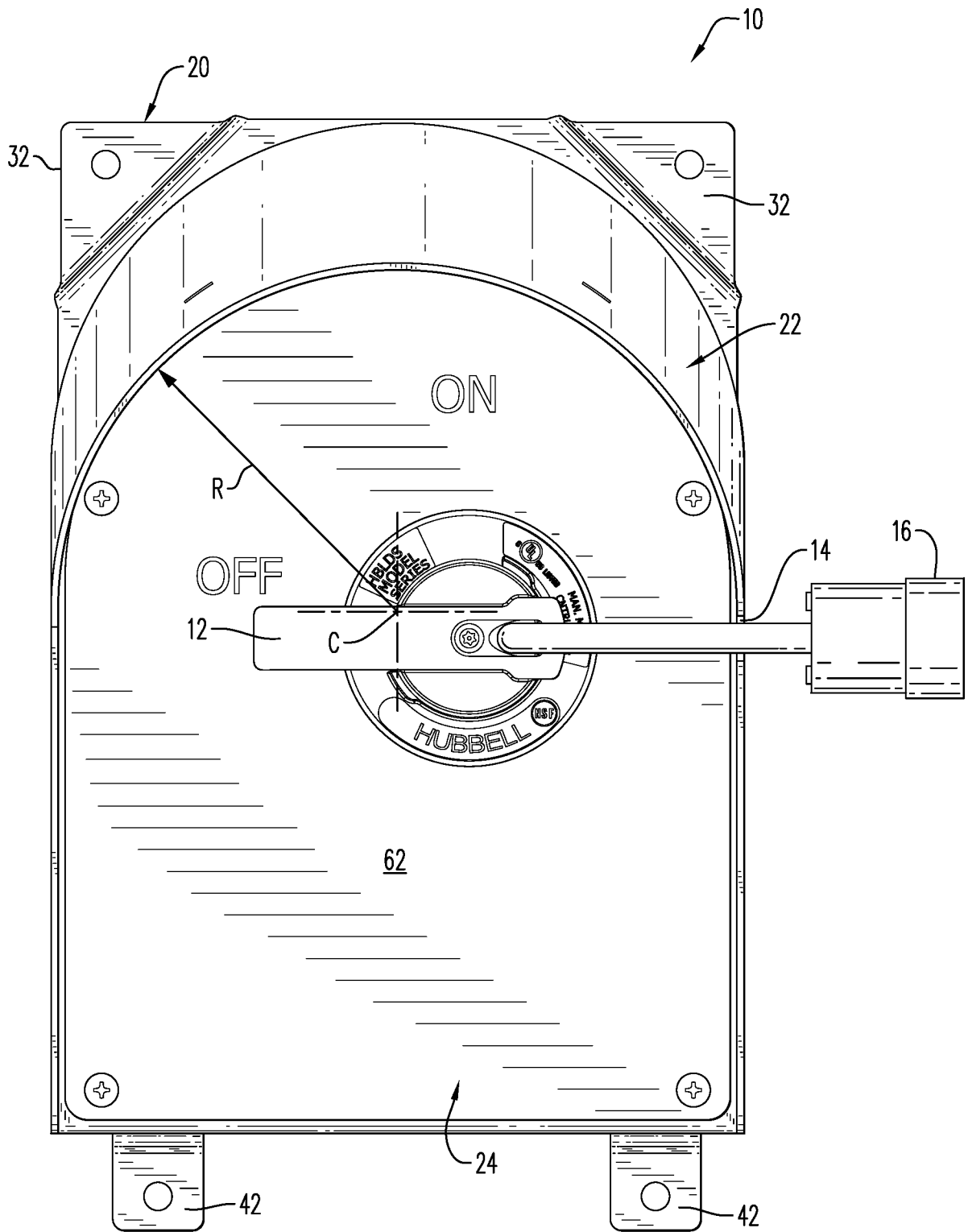

FIG. 1

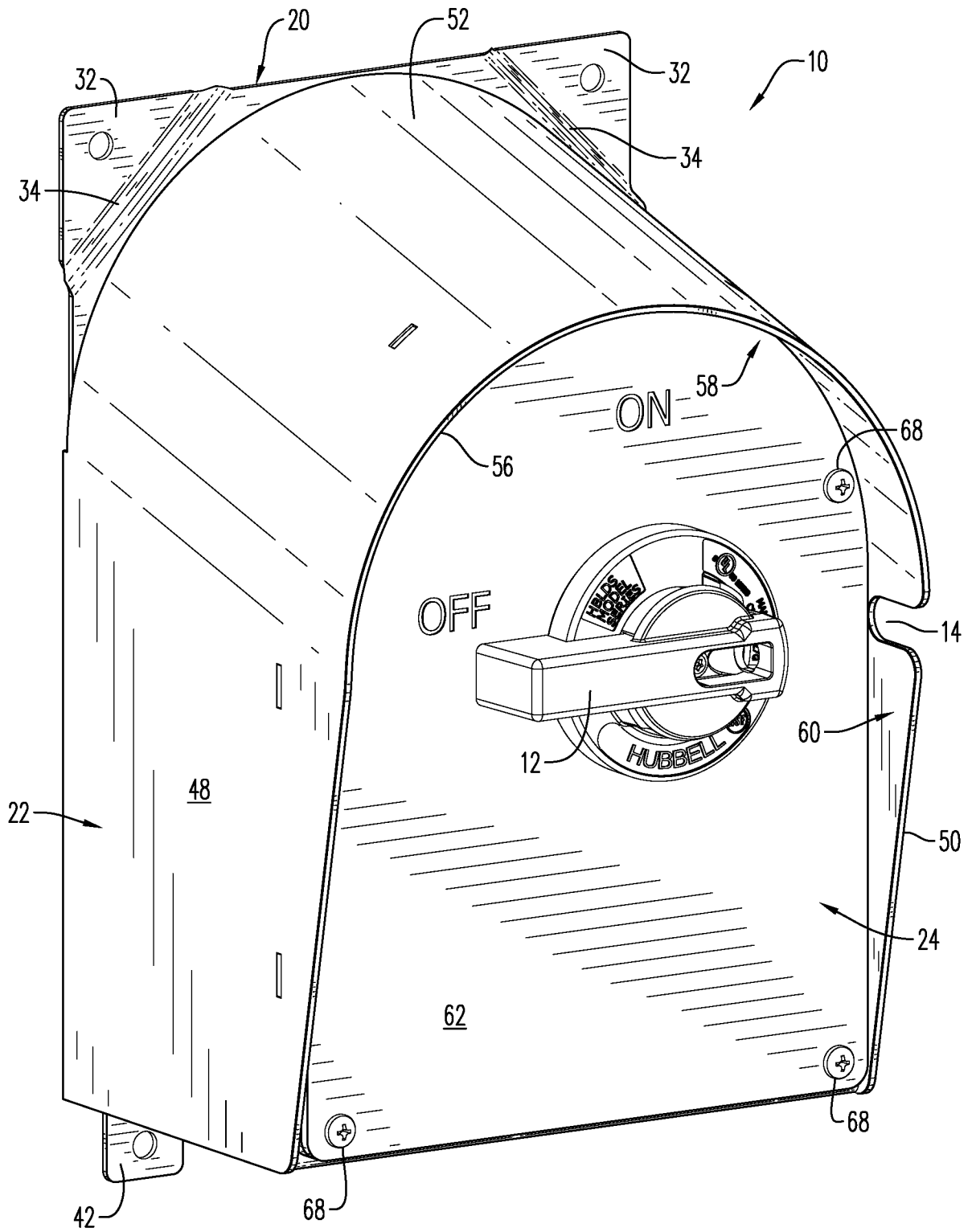

FIG. 2

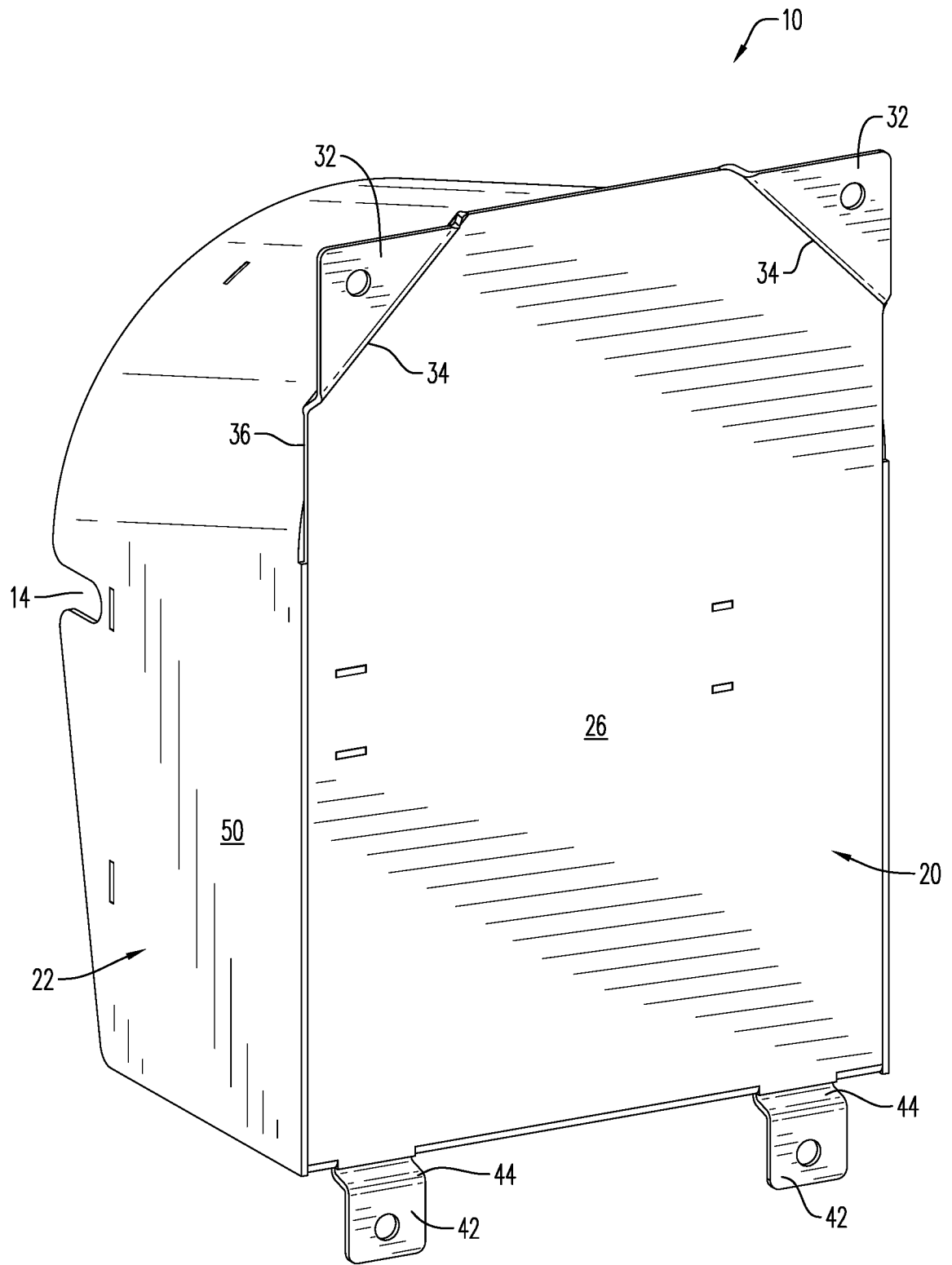

FIG. 3

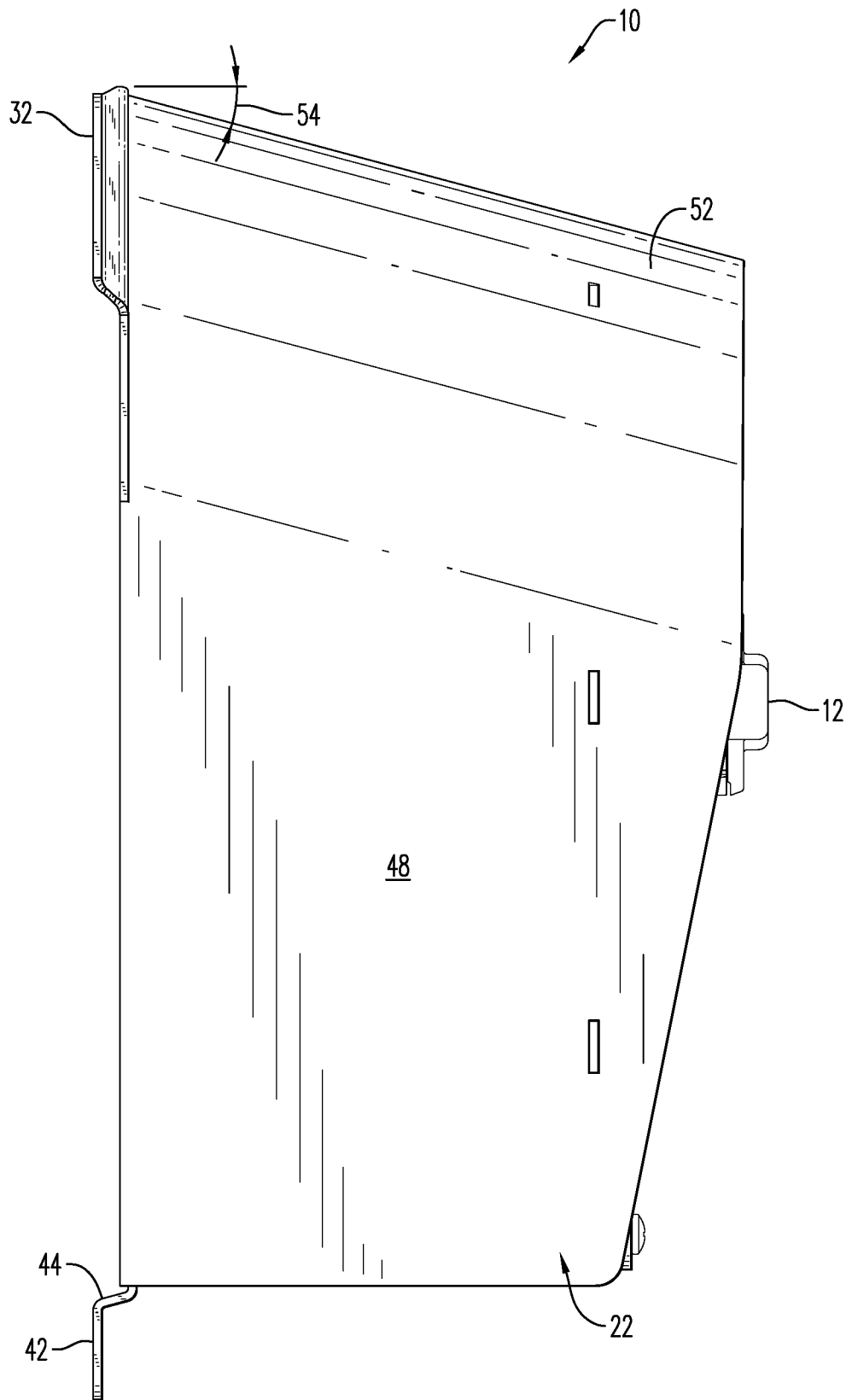

FIG. 4

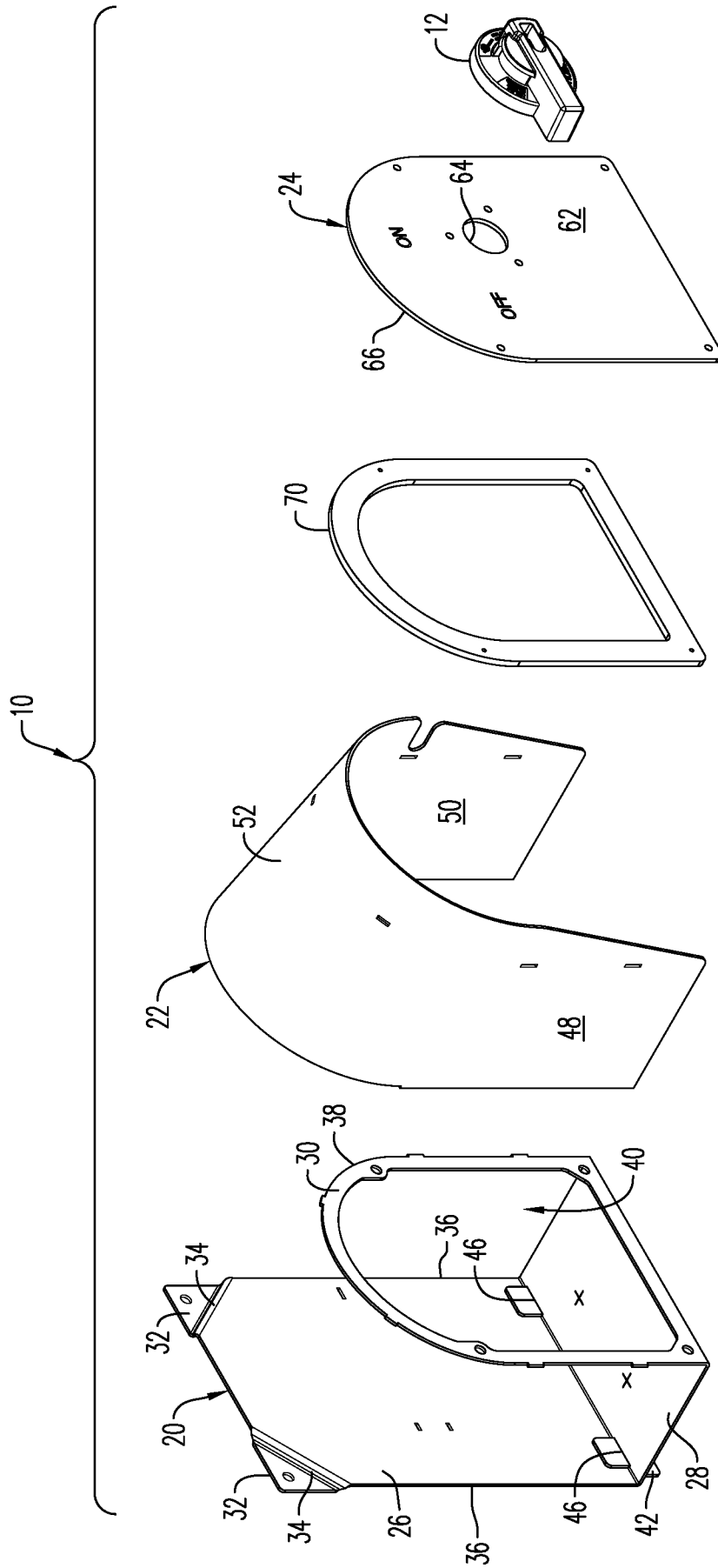
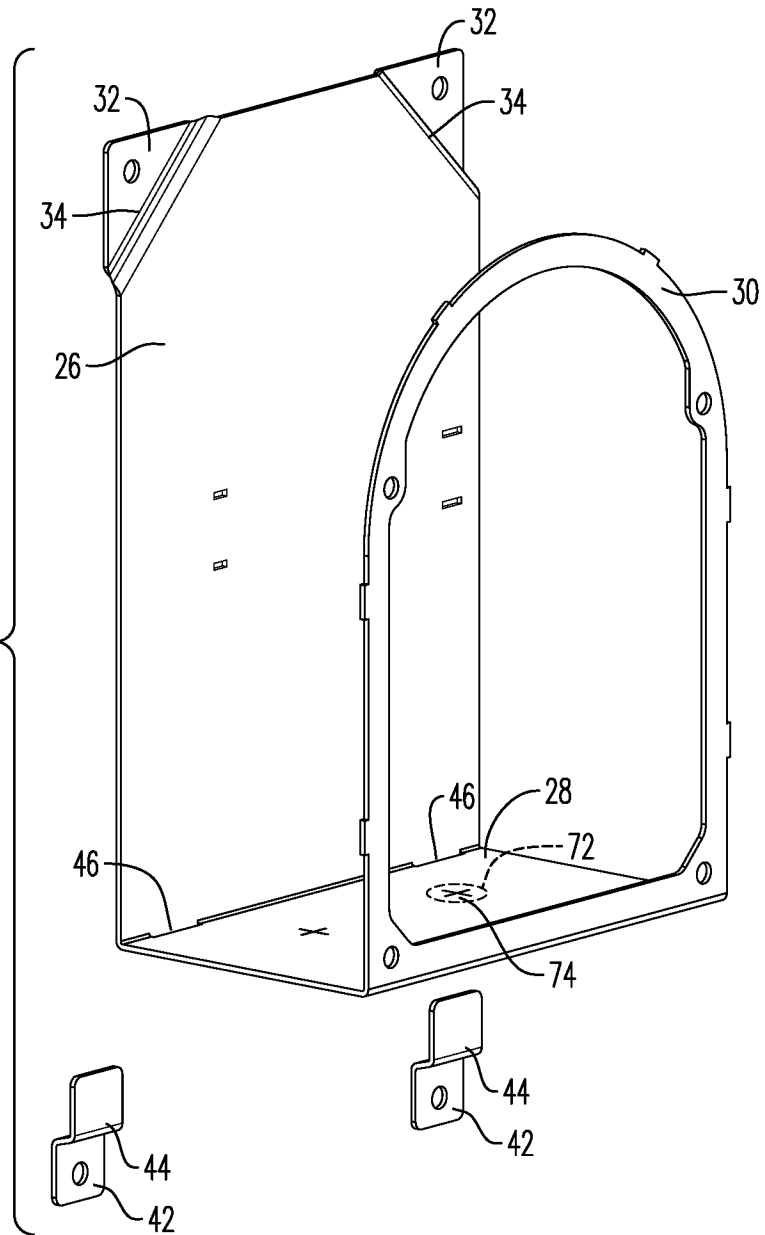

FIG. 5

FIG. 6



INTERNATIONAL SEARCH REPORT

International application No.

PCT/US 16/37854

A. CLASSIFICATION OF SUBJECT MATTER

IPC(8) - H02G 3/10, H01H 9/04, H05K 5/02, H05K 5/03, A47G 29/12, A47G 29/00 (2016.01)

CPC - H02G 3/10, H01H 9/04, H05K 5/0239, H05K 5/0217, A47G 29/1201, A47G 29/12, A47G 29/00

According to International Patent Classification (IPC) or to both national classification and IPC

B. FIELDS SEARCHED

Minimum documentation searched (classification system followed by classification symbols)

IPC(8): H02G 3/*, H05K 5/*, A47G 29/* (2016.01)

CPC: H02G 3/*, H05K 5/*, A47G 29/*

Documentation searched other than minimum documentation to the extent that such documents are included in the fields searched

IPC(8): H02G 3/*, H05K 5/*, A47G 29/* (2016.01)

CPC: H02G 3/*, H05K 5/*; A47G 29/* USPC: 312/*

Electronic data base consulted during the international search (name of data base and, where practicable, search terms used)

PatBase, Google Patents, Google Web

Keywords: wall, mount, curved, arched, convex, water, rain, weather, enclosure, seal, gasket, slope, downward, door, overhang, hinge, open, mailbox, deflect, lid, top, roof

C. DOCUMENTS CONSIDERED TO BE RELEVANT

| Category* | Citation of document, with indication, where appropriate, of the relevant passages | Relevant to claim No. |
|-----------|---------------------------------------------------------------------------------------------------|-----------------------|
| Y | GB 2463473 A (THE ORIGINAL METAL BOX COMPANY LIMITED) 17 March 2010 (17.03.2010), entire document | 1-20 |
| Y | US 7,527,190 B1 (BOWERS et al.) 05 May 2009 (05.05.2009), entire document | 1-20 |
| Y | US 2015/0076978 A1 (ELLINGSON) 19 March 2015 (19.03.2015), entire document | 3-8, 12-17 |
| A | US 1,872,323 A (NICHOLS) 16 August 1932 (16.08.1932), entire document | 1-20 |
| A | US 2007/0126320 A1 (HUANG) 07 June 2007 (07.06.2007), entire document | 1-20 |
| A | US 5,914,460 A (MOWERY et al.) 22 June 1999 (22.06.1999), entire document | 1-20 |
| A | DE 202013004440 U1 (THALES DEUTSCHLAND GMBH) 16 May 2014 (16.05.2014), entire document | 1-20 |
| A | GB 2515016 A (HELLER) 17 December 2014 (17.12.2014), entire document | 1-20 |

Further documents are listed in the continuation of Box C.

* Special categories of cited documents:

"A" document defining the general state of the art which is not considered to be of particular relevance

"E" earlier application or patent but published on or after the international filing date

"L" document which may throw doubts on priority claim(s) or which is cited to establish the publication date of another citation or other special reason (as specified)

"O" document referring to an oral disclosure, use, exhibition or other means

"P" document published prior to the international filing date but later than the priority date claimed

"T" later document published after the international filing date or priority date and not in conflict with the application but cited to understand the principle or theory underlying the invention

"X" document of particular relevance; the claimed invention cannot be considered novel or cannot be considered to involve an inventive step when the document is taken alone

"Y" document of particular relevance; the claimed invention cannot be considered to involve an inventive step when the document is combined with one or more other such documents, such combination being obvious to a person skilled in the art

"&" document member of the same patent family

Date of the actual completion of the international search

29 August 2016

Date of mailing of the international search report

13 SEP 2016

Name and mailing address of the ISA/US

Mail Stop PCT, Attn: ISA/US, Commissioner for Patents
P.O. Box 1450, Alexandria, Virginia 22313-1450

Facsimile No. 571-273-8300

Authorized officer:

Lee W. Young

PCT Helpdesk: 571-272-4300
PCT OSP: 571-272-7774