

H. K. FORBIS.  
Magazine Fire-Arm.

No. 112,795.

Patented March 21, 1871.

Fig. 1.

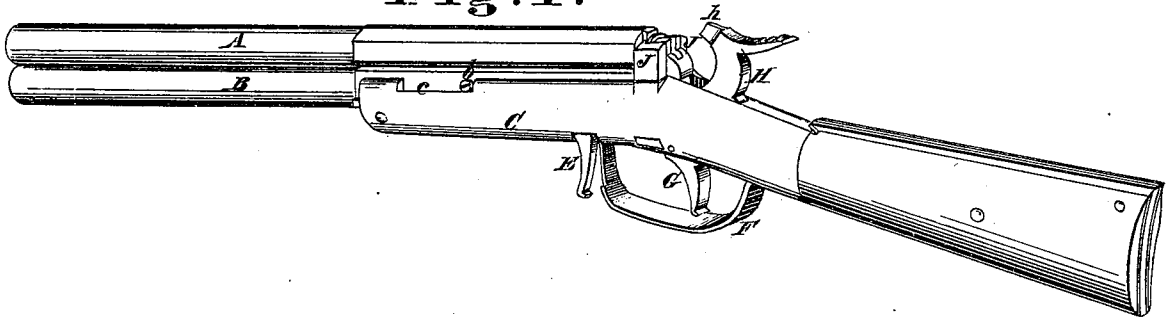

Fig. 2.

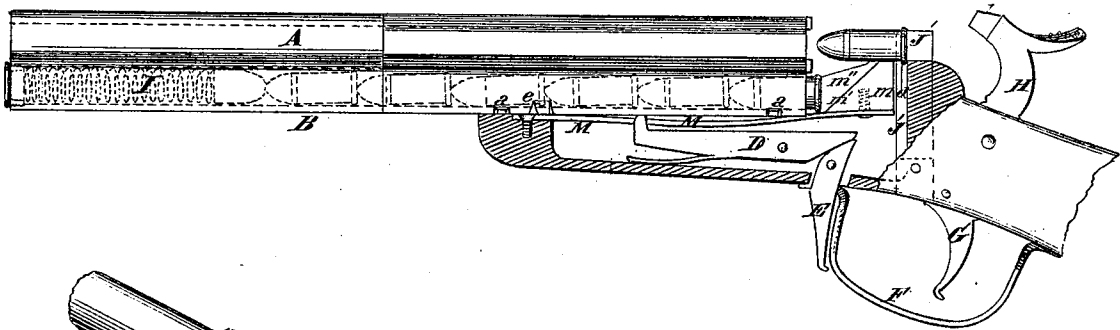

Fig. 3.

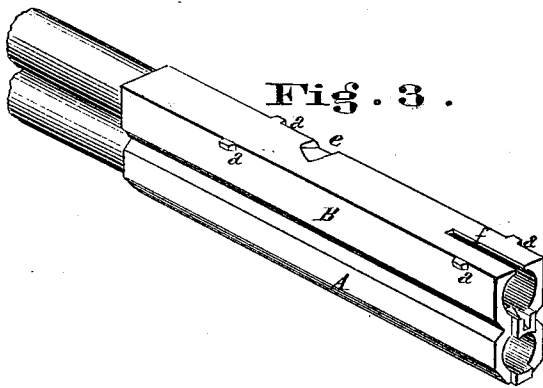
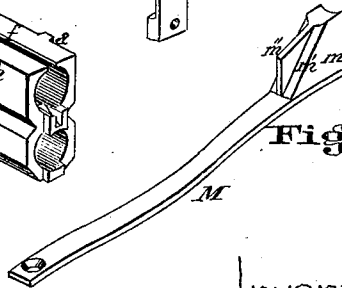

Fig. 4.



Fig. 5.



Attest  
O. J. Layman  
Geo. H. Helm

Inventor,  
Harbert K. Forbis  
By G. Millward  
Attorney

# UNITED STATES PATENT OFFICE.

HARBERT K. FORBIS, OF DANVILLE, KENTUCKY.

## IMPROVEMENT IN MAGAZINE FIRE-ARMS.

Specification forming part of Letters Patent No. **112,795**, dated March 21, 1871; antedated March 10, 1871.

### *To all whom it may concern:*

Be it known that I, HARBERT K. FORBIS, of Danville, Boyle county, State of Kentucky, have invented certain new and useful Improvements in Fire-Arms; and I hereby declare the following to be a sufficiently full, clear, and exact description thereof to enable one skilled in the art to which my invention appertains to make and use it, reference being had to the accompanying drawing, making part of this specification.

### *Nature and Objects of Invention.*

My invention relates to the class of fire-arms which embodies a supplementary barrel or chamber for containing cartridges to be rapidly fed to the discharging-barrel in succession as the exploded cartridges are thrown off after each firing; and my invention consists of peculiar devices for throwing out the case of the exploded cartridge, feeding the new cartridge to the discharging-barrel, and retaining the cartridges in the supplementary barrel during the time the discharging-barrel is being loaded. The object of my invention is to accomplish the work necessary in this class of fire-arms with more exactness, and by simpler and cheaper devices, than those heretofore used; and it consists in the combination, with reciprocating barrels, of a spring-feeder, as distinguished from a feeder operated by positive force.

### *Description of the Accompanying Drawing.*

Figure 1 is a perspective view of a rifle embodying my invention. Fig. 2 is a side elevation, partly in section, of the same. Fig. 3 is a perspective view of one side, end, and lower side of the discharging and supplementary barrels. Fig. 4 is a perspective view of one of the spring-jaws which hold the beaded end of the cartridge. Fig. 5 is a perspective view of the device which performs the double office of feeding the cartridge to the discharging-barrel and retaining the remaining cartridges in the supplementary barrel.

### *General Description.*

A is the discharging-barrel, and B the supplementary barrel for containing the supply of cartridges. The barrels are united together, and provided with flanges or lips *a*, which

fit and slide in suitable grooves in the stock C. A pin, *b*, is fixed in the lower barrel, which plays backward and forward in the recess *c* in the stock. The work of throwing off the cartridge-case after its charge has been exploded is accomplished by the movement by hand of the barrels outward, in connection with devices hereinafter explained, and the work of reloading is accomplished by moving the barrels inward. The extent of this movement is limited by the pin *b* in the recess *c*, and is a little more than equal to the length of the cartridge. In the inner position the barrels are held fast by means of the spring-catch D, whose outer end enters the notch *e* in the barrel. This catch is relieved by the trigger E when it is necessary to move the barrels outward. The stock C is provided with the customary guard F, trigger G, and hammer H, the latter being provided with the tongue *h*, which, by percussion, explodes the cartridge. The cartridges can be placed in the barrel B from either end, and are kept constantly pressed toward the breech by means of the coiled spring I. The fresh cartridge, or the exploded case which occupies the breech, is at all times held between the spring-jaws J J', which are fastened at the lower end to the stock, and at the upper end are constructed with lips *d*, which engage over the beaded end of the cartridge, in the manner shown in Fig. 2. Being elastic, these jaws will tightly enclasp the end of the cartridge, and will accommodate cartridges varying slightly in size.

The feeding device is clearly shown in Fig. 5.

It consists of a spring, M, which is fastened to the stock C by screw K, and constructed with an enlarged end, *m*, slightly concave on top to fit the cartridge, and with an inclined face, *m'*, which enables the barrel B to force the spring down. The enlarged end *m* is also constructed with a projecting tongue, *m''*, which serves, when the feeder is forcing a fresh cartridge up, to retain the remaining cartridges in place. When the barrels are moving inward this tongue *m''* occupies the slot *f* in the barrel B.

### *Operation.*

When a load has been fired the trigger E is pressed by the finger and the barrels forcibly moved outward to the extent of the recess *c*. The bead of the end of the cartridge being

held by the jaws J J', this movement serves to withdraw the exploded case from the barrel A, and when the case is free from the barrel the feeder M, which at this time has a new cartridge in position on the concave top of the projection *m*, forces up the new cartridge to the position shown in Fig. 2, thus forcibly displacing and throwing off the exploded case. The new cartridge is loaded by simply moving the barrels inward until the catch E engages in the notch *e*.

*Claims.*

1. In combination with the sliding barrels

A B, the spring feeding device M *m m' m''*, the parts being constructed and arranged substantially as set forth.

2. In connection with the barrels A B and feeder M *m m' m''*, the lipped spring-jaws J J' *d*, operating as described, and for the purpose specified.

In testimony of which invention I hereunto set my hand.

HARBERT K. FORBIS.

Witnesses:

FRANK MILLWARD,  
J. L. WARTMANN.