

(12) STANDARD PATENT
(19) AUSTRALIAN PATENT OFFICE

(11) Application No. **AU 2004201512 B2**

(54) Title
Propellant holder for an explosion-driven setting tool and an explosion-driven setting tool

(51) International Patent Classification(s)
B25C 1/08 (2006.01) **B25C 1/16** (2006.01)

(21) Application No: **2004201512** (22) Date of Filing: **2004.04.08**

(30) Priority Data

(31) Number	(32) Date	(33) Country
10319646.3	2003.05.02	DE

(43) Publication Date: **2004.11.18**

(43) Publication Journal Date: **2004.11.18**

(44) Accepted Journal Date: **2010.01.07**

(71) Applicant(s)
Hilti Aktiengesellschaft

(72) Inventor(s)
Ehmig, Gerhard;Dittrich, Tilo

(74) Agent / Attorney
Shelston IP, 60 Margaret Street, Sydney, NSW, 2000

(56) Related Art
US 20010045892
US 6247625

ABSTRACT OF THE DISCLOSURE

An explosion-driven setting tool includes a setting mechanism (12) driven by a propellant (23), an ignition unit (18) for igniting the propellant (23), a receptacle (15) for receiving a propellant holder (20), a data communication interface (31) for receiving and
5 transmitting data of the propellant holder (20), and a data processing unit (30) for receiving data transmitted by the data communication interface (31) and connected with a display (50) for displaying the propellant supply level (27) of the propellant (23) in the propellant holder having a housing (21) with an interior space (22) for receiving the propellant (23), and a data storage identification unit (40) in which the propellant supply
10 level (27) is stored for being read-out.

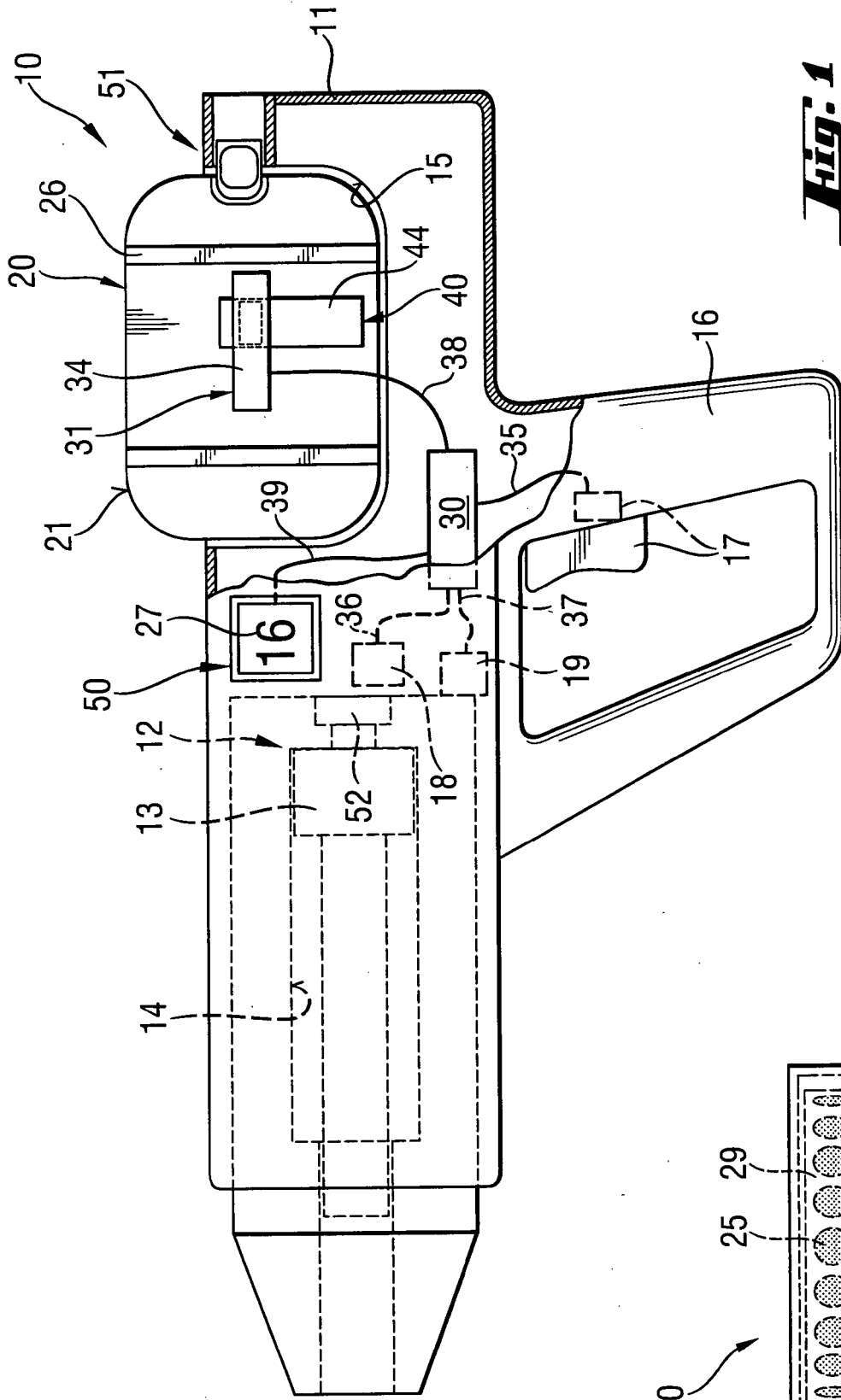

Fig. 1

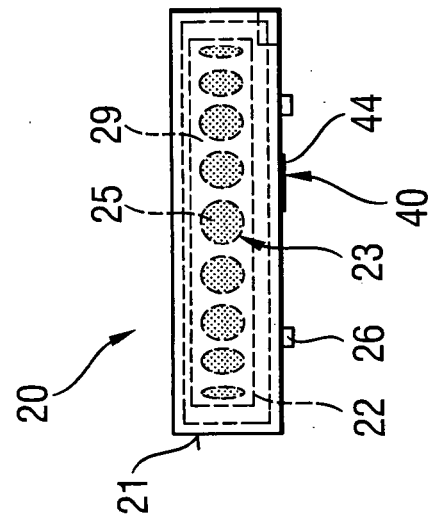

Fig. 2

AUSTRALIA

PATENTS ACT 1990

COMPLETE SPECIFICATION

FOR A STANDARD PATENT

ORIGINAL

Name of Applicants: **Hilti Aktiengesellschaft**

Actual Inventors: **Gerhard Ehmig and Tilo Dittrich**

Address for Service: **Shelston IP**
60 MARGARET STREET
SYDNEY NSW 2000

CCN: 3710000352

Invention Title: **PROPELLANT HOLDER FOR AN EXPLOSION-
DRIVEN SETTING TOOL AND AN EXPLOSION-
DRIVEN SETTING TOOL**

The following statement is a full description of this invention, including the best method of performing it known to us:-

File: 42163AUP00

BACKGROUND OF THE INVENTION

1. Field of the Invention

5 The present invention relates to a propellant holder for an explosion driven setting tool and having a housing with an inner space for receiving the propellant, and to an explosion-driven setting tool including a setting mechanism driven by a propellant, an ignition unit for igniting the propellant, and a receptacle for receiving a propellant holder.

2. Description of the Prior Art

10 Any discussion of the prior art throughout the specification should in no way be considered as an admission that such prior art is widely known or forms part of common general knowledge in the field.

The propellant holder of the type described above can be filled with a powder fuel in form of cartridges or pellets but can also be filled with a fluid or gaseous fuel, with the powder, fluid or gaseous fuel forming the propellant for driving a setting mechanism of the setting tool.

15 With contemporary setting tools driven with a solid fuel, the cartridges or pellets are carried by a magazine strip which serves as a propellant holder and in which a plurality of pellet charges in blisters or cartridges are arranged. The magazine strips can, thus, be formed as blister or cartridge strips, respectively.

20 A propellant holder in form of a magazine strip is disclosed, for *e.g.*, in U.S. Patent No. 5,811,717, with ten propellant charges being arranged on the strip. At the height of the penultimate propellant charge, there is provided an indicator mark on the strip. The indicator mark, when it becomes visible in the setting tool, indicates to the user that only one propellant charge remains on the magazine strip. No other information about the propellant charge is available to the user.

25 In order to ensure that a large number of setting processes can be performed with a setting tool without replacement of cartridge, blister, or magazine strips necessary for

performing the setting processes, there is proposed to use magazine strips having an increased length.

U.S. Patent No. 4,204,473 discloses an explosion-driven setting tool and a cartridge strip therefor having a large number of propellant charges arranged in a box-shaped magazine. The cartridge or magazine strips are arranged in the box in a predetermined position.

The drawback of the box-shaped magazine of U.S. Patent No. 4,204,473 consists in that no information is available to the user about a number of the propellant charges that remains in the box at a predetermined time period.

A propellant holder for fluid and/or gaseous fuel is formed as a pressure container. Such pressure containers, which serve as propellant holders, are disclosed, for *e.g.*, in German Patent DE 197 46 018 C2.

U.S. Patent No. 6,336,453 discloses an aerosol container with a device having a window in which a number of remaining aerosol portions in the container is shown with figures, color codes, or graphic markings. The drawback of the indicator of U.S. Patent No. 6,336,453 consists in that the data are not visible when the container, for *e.g.*, is located in a receptacle of a dispenser. To ascertain as to the number of the remaining aerosol portions, the user has to retract the container from the receptacle, which leads to loss of time.

OBJECT OF THE INVENTION

Accordingly, it is an object of the present invention to overcome or ameliorate at least one of the disadvantages of the prior art, or to provide a useful alternative.

It is an object of the present invention in at least one preferred form to provide a propellant holder and a setting tool with the propellant holder in which the drawbacks of the prior art holders and setting tools are eliminated.

It is an object of the present invention in at least one preferred form to provide a propellant holder and a setting tool with which a number of remaining propellant charges can be easily ascertained.

SUMMARY OF THE INVENTION

5 One aspect of the invention provides a propellant holder for being releasably mounted in a setting tool having a data communication interface, said propellant holder comprising a housing having an interior space for receiving propellant; and a data storage identification unit affixed to said housing and in which a propellant supply level is stored for being read-out by the data communication interface of the setting tool.

10 Unless the context clearly requires otherwise, throughout the description and the claims, the words "comprise", "comprising", and the like are to be construed in an inclusive sense as opposed to an exclusive or exhaustive sense; that is to say, in the sense of "including, but not limited to".

15 In this aspect of the present invention, the provision of the propellant holder with a data storage identification unit permits to store therein not only the supply level data but also identification data of the propellant. These data advantageously can be easily read out electronically by the setting tool and can become easily available to the user.

20 Another aspect of the present invention provides an explosion-driven setting tool, comprising a setting mechanism driven by a propellant; ignition means for igniting the propellant; a receptacle for receiving a propellant holder having a data storage identification unit; a display for displaying a propellant supply level in the propellant holder; a data communication interface for receiving and transmitting data with the data storage identification unit of the propellant holder; and a data processing unit operationally connected with the data communication interface and the display.

25 A further aspect of the invention provides an explosion-driven setting tool, comprising a setting mechanism driven by a propellant; ignition means for igniting the propellant; a receptacle for receiving a propellant holder which has a housing with an

interior space for receiving propellant, the propellant holder further including a data storage identification unit in which a propellant supply level is stored for being read-out; a display for displaying the propellant supply level; a data communication interface for receiving identification data read-out from the data storage identification unit; and a data processing unit for receiving the identification data from the data communication interface and connected with the display for communicating the propellant supply level thereto.

In these aspects of the present invention, the provision of the setting tool with a display, a data communication interface, and a data processing unit connected with both the data communication interface and the display, permits the user to ascertain at any time the propellant supply level in the propellant holder. The retraction of the propellant holder from the setting tool receptacle to ascertain the supply level is not necessary any more.

According to an advantageous embodiment of the propellant holder, the holder has a data communication interface connected with the data storage identification unit. In the embodiment of an inventive propellant holder, which can be economically produced, the data storage identification unit is formed as EEPROM or as a magnetic strip.

In a further, economically produced propellant holder, the data communication interface is formed as an antenna, preferably as a transponder antenna, or as a contact element that cooperates with a mating contact element provided in the propellant holder receptacle of the setting tool.

The inventive propellant holder can be formed also, for *e.g.*, as a pressure can or pressure container for a gaseous and/or liquid fuel. However, the inventive propellant holder can be also formed as a box or a cassette for solid propellant charges in form of a cartridge or blister strip.

According to an advantageous embodiment of the setting tool, the data processing unit is connected with the ignition device or a device for shifting the same between operational and non-operational modes. In the operation mode of the ignition device, the

setting tool can perform a setting process, as in this mode, the propellant is ignited by the ignition device. According to a particular advantageous embodiment of the setting tool, the data processing unit actuates the ignition device for igniting the propellant when the following conditions are met, namely, (i) the data processing unit has received
5 identification data which were read-out from the data storage identification unit of the propellant holder received in the receptacle of the setting tool and which are recognized by the data processing unit as authorized identification data of a propellant suitable for the setting tool, and the propellant supply level data read-out from the data storage
10 indemnification device and communicated to the data processing unit indicates that the propellant holder is not empty. This embodiment of the setting tool is particularly user-friendly.

In order to reduce the data transmission path between the data communication interfaces, which are provided, respectively, on the holder and the setting tool, as much as is possible, the data communication interface of the setting tool is located in a region of
15 the propellant holder receptacle. The data communication interface of the setting tool can be formed as antenna or as a transponder antenna, or a mating contact element, or a magnetic strip reader. The data communication interfaces (and other electronic components) of the propellant holder and the setting tool are adapted to each other to form an ideal propellant holder system.

20 The novel features of the present invention are set forth in the appended claims. The invention itself, however both as to its construction and its mode operation, together with additional advantages thereof, will be best understood from the following detailed description of preferred embodiments, when read with reference to the accompanying drawings.

25 **BRIEF DESCRIPTION OF THE DRAWINGS:**

A preferred embodiment of the invention will now be described, by way of example only, with reference to the accompanying drawings in which:

- Fig. 1 is a schematic, partially cross-sectional view of a setting tool with a propellant holder according to one embodiment of the present invention received in the setting tool receptacle;
- Fig. 2 is a plan view of the propellant holder shown in Fig. 1;
- Fig. 3 is a schematic, partially cross-sectional view of a setting tool with another embodiment of a propellant holder received in the setting tool receptacle;
- Fig. 4 is a plan view of the propellant holder shown in Fig. 3;
- Fig. 5 is a schematic, partially cross-sectional view of a setting tool with a further embodiment of a propellant holder received in the setting tool receptacle;
- Fig. 6 is a side view of the propellant holder shown in Fig. 5;
- Fig. 7 is a bottom view of the propellant holder shown in Fig. 6; and
- Fig. 8 is a side view of a still further embodiment of a propellant holder.

DETAILED DESCRIPTION OF THE PREFERRED EMBODIMENTS

A first embodiment of a propellant holder 20 according to the present invention, which is shown in Figs. 1 and 2, is designed for use in a setting tool 10 schematically shown in Fig. 1. The setting tool has a housing 11 and a setting mechanism 12 located in
5 the housing 11. The setting mechanism 12 includes a piston guide 14, a drive piston 13 displaceable in the piston guide 14, and a cartridge receptacle 52 for receiving a propellant 23 (see Fig. 2), for *e.g.*, a solid propellant charge 25 located in a cartridge or a blister. The propellant 23, which is located in the cartridge receptacle 52, can be ignited, electronically or electromechanically, by an ignition device 18. After ignition, the drive

piston 13 is driven by expendable explosion gases formed in the cartridge receptacle 52 and performs a setting process, for *e.g.*, driving a bolt or a nail, which is located in the bolt guide of the setting tool, into a constructional component (not shown). The setting tool 10 further includes a handle 16 on which an actuation switch 17 is located. The switch 17 is connected by an electrical conductor 35 with a data processing unit 30. The data processing unit 30 transmits, in response to actuation of the switch 17 by the setting tool user, an ignition signal to the ignition device 18 with which the data processing unit 30 is connected by an electrical conductor 36. The setting tool 10 further includes a safety switch 19 which is connected with the data processing unit 30 by an electrical conductor 37. The safety switch 19 generates a signal, which is transmitted to the data processing unit 30, when the setting tool 10 is pressed against a constructional component into which a fastening element is to be driven with the setting tool.

The setting tool 10 further has a receptacle 15 for receiving the propellant holder 20. The propellant holder 20 is temporary secured in the receptacle 15 with a locking device 51. For securing the propellant holder 20 in the receptacle 15 in a predetermined position, there are provided guide grooves (not shown) which cooperate with guide elements 26 provided on the propellant holder 20. Retaining of the propellant holder is very important because there is provided, in the region of the receptacle 15, a data communication interface 31 (shown as being suspended) which is formed in the embodiment shown in the drawing as a magnetic strip reader 34. The magnetic strip reader 34 is connected with the data processing unit 30 by an electrical conductor 38 for exchanging data.

On the outer side of the housing 11, there is arranged an optical display 50 which is connected with the data processing unit 30 by an electrical conductor 39. The display 50 displays supply level data 27 indicating the supply level of the propellant holder 20 located in the receptacle 15 of the setting tool 10.

The propellant holder 20, which is shown in Figs. 1 and 2, has a housing 21 with an interior space 22 in which propellant 23 is located, in form of solid propellant charges

25 arranged in a blister strip 29. On a side wall of the housing 21, there is provided a data storage identification unit 40 in form of a magnetic strip 44. In the data storage identification unit 40, the information about the propellant 23 is stored for providing identification data. The data storage identification unit 40 also contains supply level data 27 indicating a number of solid propellant charges 25 available in the propellant holder 20.

When the propellant holder 20 is received in the receptacle 15 of the setting tool 10, the blister strip 29 with the solid propellant charges 25 is displaced into the setting tool 10, to place a solid propellant charge 25 into the cartridge receptacle 52.

10 The setting tool 10 and the propellant holder 20 interact in the following way.

After the propellant holder 20 has been inserted in the receptacle 15 of the setting tool 10, the identification data and the propellant supply level are transmitted from the magnetic strip 44 or the data storage identification unit 40 via the data communication interface 31 or the magnetic strip reader 34 to the data processing unit 30.

15 If the identification data are recognized as acceptable data, and the propellant supply level indicates that at least one solid propellant charge remains in the propellant holder 20, the data processing unit 30, which can be formed, for *e.g.*, as a microprocessor or an integrated circuit, puts the setting tool 10 into an operational mode. The propellant supply level 27 is displayed on the display 50. Upon a solid propellant charge 25 being
20 consumed, the data processing unit 30 changes the propellant supply level 27 in the data storage identification unit 40 via the data communication interface 31, so that the data storage identification unit 40 always stores the actual propellant supply level 27.

Upon the last solid propellant charge 25 being consumed, the display 50 displays that no solid propellant charges remain, and the data processing unit 30 puts the setting
25 tool 10 into its non-operational mode.

Figs. 3 and 4 show a further embodiment of a propellant holder 20 according to the present invention, which is inserted in the setting tool 10. The propellant holder 20

shown in Figs. 3 and 4 differs from that shown in Figs. 1-2 in that the data storage identification unit is formed as EEPROM (electronically erasable programmable read-only memory) 45 with an integrated data communication interface 41 in form of contact elements 43. The setting tool 10, which is shown in Fig. 3, differs from that shown in Fig. 1 in that the data communication interface 31 is formed as mating contact elements 33. All of the other functions and elements are the same as those of the setting tool in Fig. 1.

A still further embodiment of the propellant holder 20 is shown in Fig. 5 with the propellant being a gaseous or liquid fuel 24. The setting tool 10, in which this propellant holder is used, has, instead of a cartridge receptacle, a combustion chamber 53 that is provided at a rear end of the piston guide 14, with respect to a setting direction. The propellant, *i.e.*, fuel is fed into the combustion chamber 53 by a metering device 28 provided downstream of the propellant holder 20. The receptacle 15 is formed for receiving a pressure container forming the propellant holder. A detailed description of the propellant holder 20 is given further below with reference to Figs. 6-8. The data communication interface 31 includes a transponder antenna 32, which is connected with data processing unit 30 by an electrical conductor 38.

The pressure container, which formed the propellant holder 20, has a housing 21 with an interior space 22 in which the propellant 23 is located, in the form of gaseous or liquid fuel 24. At the bottom of the propellant holder 20, there is provided a transponder tag in form of a carrier element 46 for carrying a transponder antenna 42, forming the data storage identification unit 40 and the data communication interface 41. The carrier element 46 can be formed, for *e.g.*, of a plastic film.

The above-described data exchange takes place between the data storage identification unit 40 of the propellant holder 20 and the data processing unit 30 of the setting tool 10 through the data communication interfaces 31, 41. The display 50 displays the remaining amount of the propellant 23, for *e.g.*, in ml, cl, or the like or displays an estimated number of remaining fuel portions and a corresponding number of

possible settings. In the embodiment of a propellant holder 20 shown in Fig. 8, the transponder tag or the carrier element 46 is provided on the side surface of the propellant holder.

5 The functioning of the setting tool with a holder for fuel propellant is substantially the same as that of Figs. 1 to 4.

10 Though the present invention was shown and described with references to the preferred embodiments, such are merely illustrative of the present invention and are not to be construed as a limitation thereof and various modifications of the present invention will be apparent to those skilled in the art. It is therefore not intended that the present invention be limited to the disclosed embodiments or details thereof, and the present invention includes all variations and/or alternative embodiments within the spirit and scope of the present invention as defined by the appended claims.

THE CLAIMS DEFINING THE INVENTION ARE AS FOLLOWS:-

1. A propellant holder for being releasably mounted in a setting tool having a data communication interface, said propellant holder comprising a housing having an interior space for receiving propellant; and a data storage identification unit
5 affixed to said housing and in which a propellant supply level is stored for being read-out by the data communication interface of the setting tool.
2. A propellant holder according to claim 1, further comprising a data communication interface connected with the data storage identification unit.
3. A propellant holder according to claim 2, wherein the data communication
10 interface is formed as an antenna.
4. A propellant holder according to claim 3, wherein the antenna is formed as a transponder antenna.
5. A propellant holder according to claim 2, wherein the data communication interface is formed as a contact element.
- 15 6. A propellant holder according to any one of the preceding claims, wherein the data storage identification unit is formed as EEPROM.
7. A propellant holder according to any one of claims 1 to 5, wherein the data storage identification unit is formed as a magnetic strip.
8. A propellant holder according to any one of the preceding claims, wherein the
20 propellant is formed of a plurality of solid propellant charges.
9. A propellant holder according to any one of claims 1 to 7, wherein the propellant holder is formed as a pressure container for at least one of gaseous fuel and liquid fuel.
- 25 10. A propellant holder according to any one of the preceding claims, wherein said data storage identification unit further stores propellant identification data.

11. An explosion-driven setting tool, comprising a setting mechanism driven by a propellant; ignition means for igniting the propellant; a receptacle for receiving a propellant holder having a data storage identification unit; a display for displaying a propellant supply level in the propellant holder; a data communication interface for receiving and transmitting data with the data storage identification unit of the propellant holder; and a data processing unit operationally connected with the data communication interface and the display.
12. An explosion-driven setting tool according to Claim 11, wherein the data processing unit is connected with the ignition means for controlling the same.
13. An explosion-driven setting tool according to Claim 12, wherein the data processing unit actuates the ignition means for igniting the propellant when the following conditions are met:
- the data processing unit receives identification data which are read-out from the data storage identification unit of the propellant holder received in the receptacle of the setting tool and which are recognized by the data processing unit as authorized identification data of a propellant suitable for the setting tool; and
- the propellant supply level data read-out from the data storage identification means and communicated to the data processing unit indicates that the propellant holder is not empty.
14. An explosion-driven setting tool according to any one of claims 11 to 13, wherein the data communication interface is located in a region of the propellant holder receptacle.
15. An explosion-driven setting tool according to any one of claims 11 to 14, wherein the data communication interface is formed as an antenna.
16. An explosion-driven setting tool according to any one of claims 11 to 14, wherein the data communication interface is formed as a mating contact element.
17. An explosion-driven setting tool according to any one of claims 11 to 14, wherein the data communication interface is formed as a magnetic strip reader.

18. An explosion-driven setting tool, comprising a setting mechanism driven by a propellant; ignition means for igniting the propellant; a receptacle for receiving a propellant holder which has a housing with an interior space for receiving propellant, the propellant holder further including and a data storage identification unit in which a propellant supply level is stored for being read-out; a display for displaying the propellant supply level; a data communication interface for receiving identification data read-out from the data storage identification unit; and a data processing unit for receiving the identification data from the data communication interface and connected with the display for communicating the propellant supply level thereto.
- 5
- 10
19. A propellant holder for a setting tool, substantially as herein described with reference to any one of the embodiments of the invention illustrated in the accompanying drawings and/or examples.
20. An explosion-driven setting tool, substantially as herein described with reference to any one of the embodiments of the invention illustrated in the accompanying drawings and/or examples.
- 15

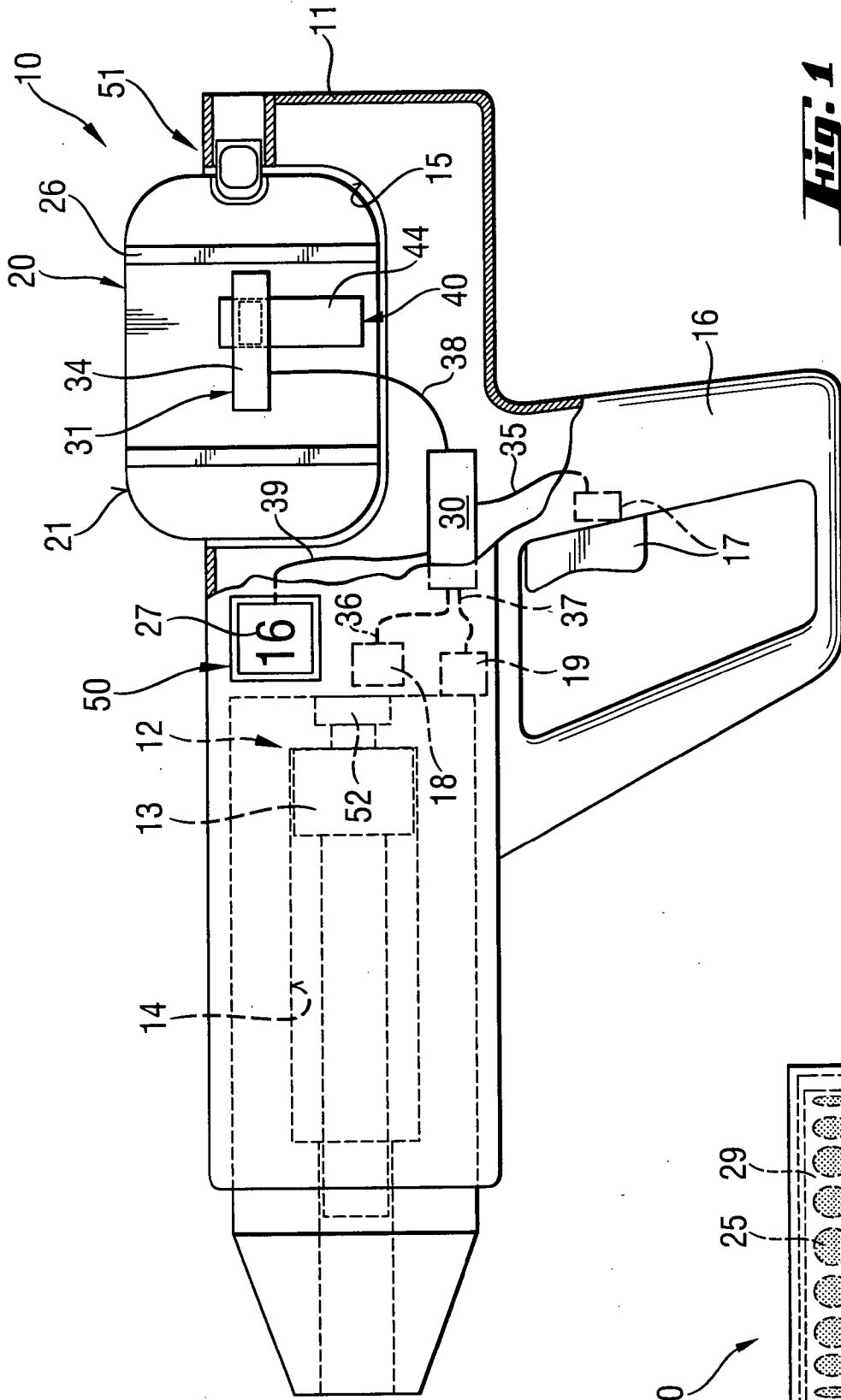

Fig. 1

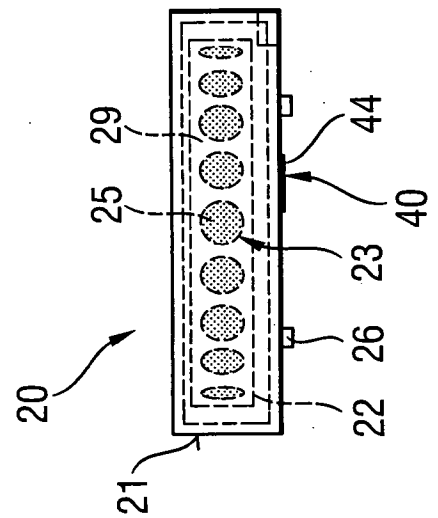

Fig. 2

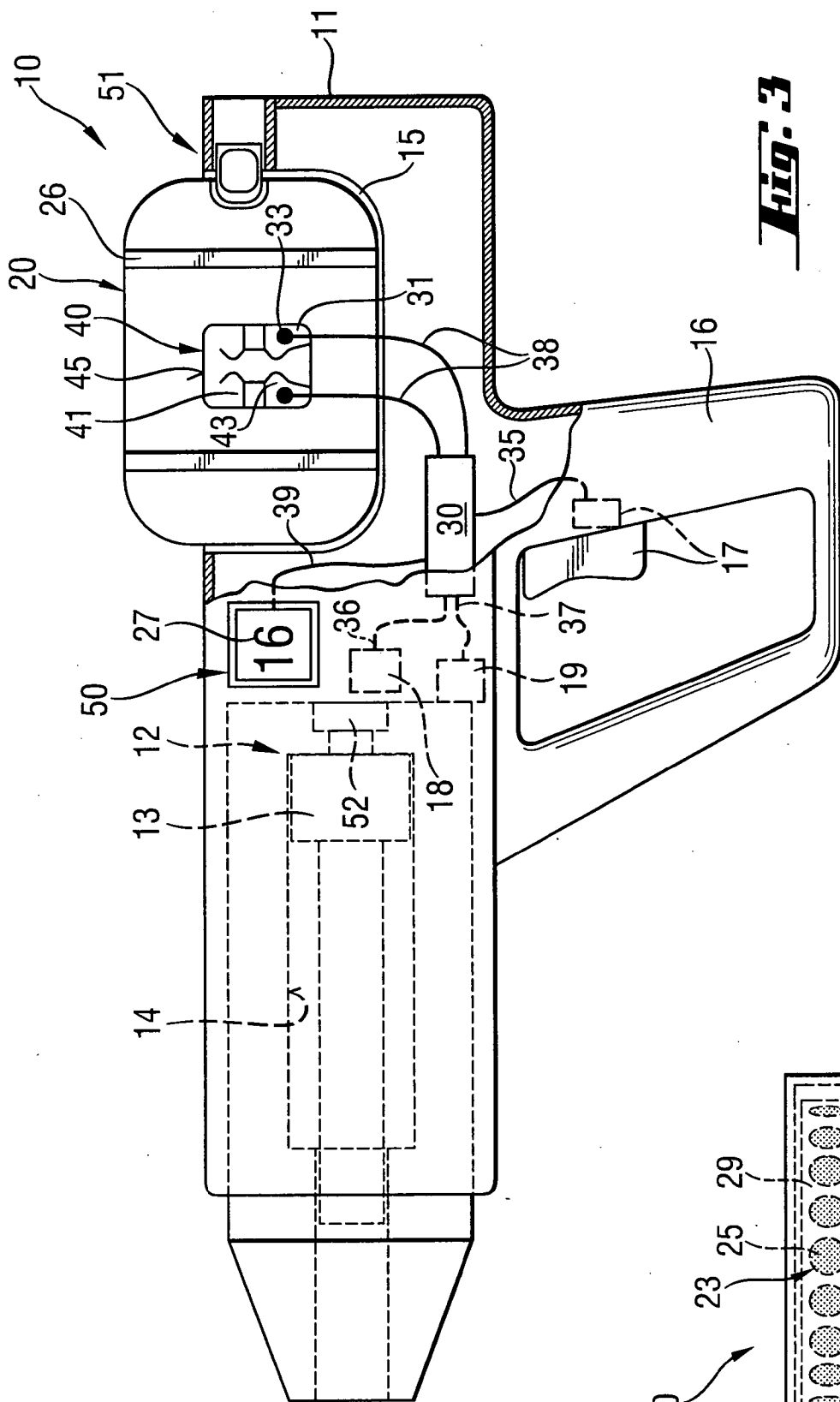

Fig. 3

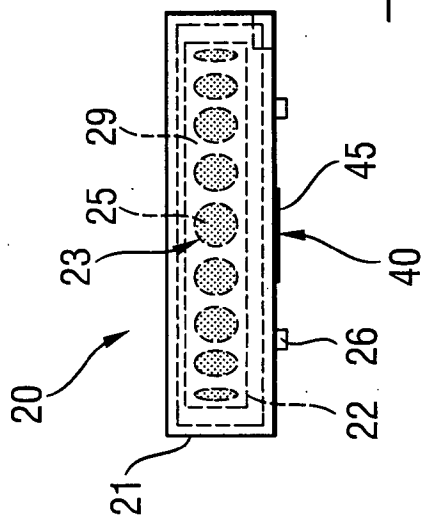

Fig. 4

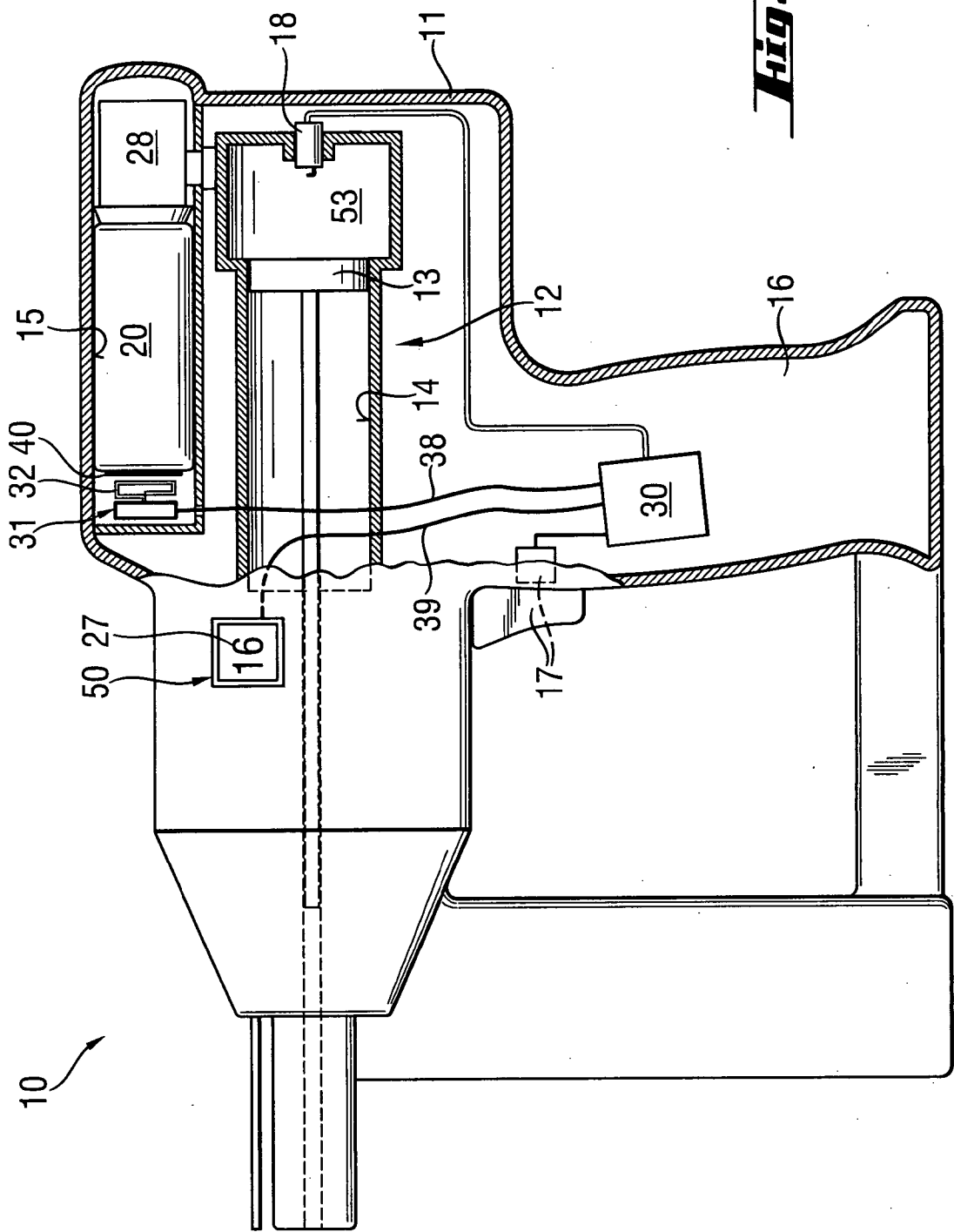

Fig. 5

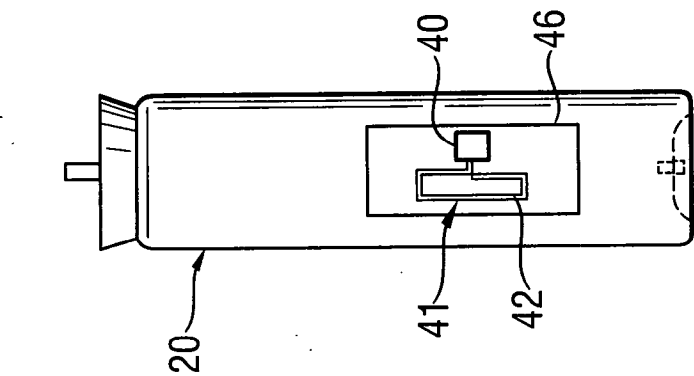

Fig. 1

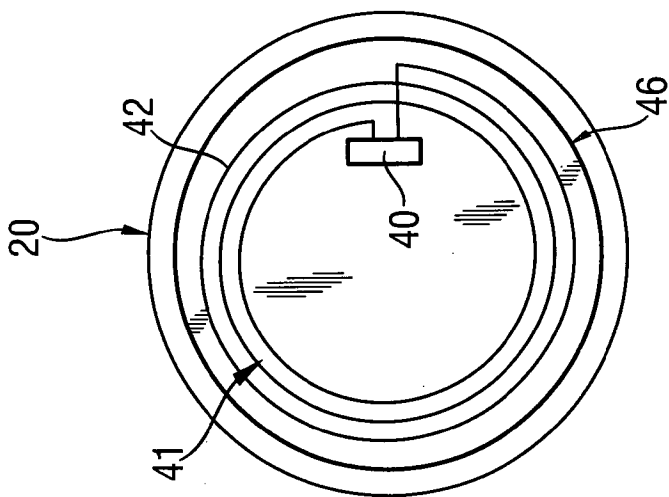

Fig. 2

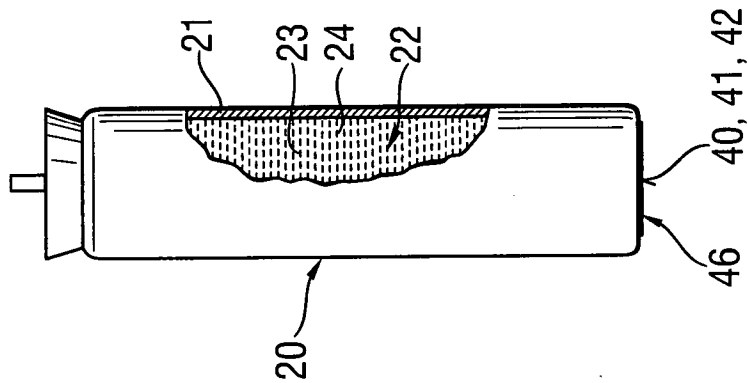

Fig. 3