



- (51) International Patent Classification:
H02G 1/00 (2006.01) H02G 3/32 (2006.01)
H02G 3/04 (2006.01)
- (21) International Application Number:
PCT/GB2012/051423
- (22) International Filing Date:
20 June 2012 (20.06.2012)
- (25) Filing Language: English
- (26) Publication Language: English
- (30) Priority Data:
1110701.8 24 June 2011 (24.06.2011) GB
- (71) Applicant (for all designated States except US): **RETRO ECO LIMITED** [GB/GB]; McCrone House, 155a Leighton Road, London NW5 2RD (GB).
- (72) Inventors; and
- (75) Inventors/Applicants (for US only): **WAITE, James** [GB/GB]; Retro Eco Limited, McCrone House, 155a Leighton Road, London NW5 2RD (GB). **WEBB, Lawrence** [GB/GB]; Retro Eco Limited, McCrone House, 155a Leighton Road, London NW5 2RD (GB). **HOBBS, Richard** [GB/GB]; Retro Eco Limited, McCrone House, 155a Leighton Road, London NW5 2RD (GB).
- (74) Agent: **GREENE, Simon**; Prospect House, 8 Pembroke Road, Sevenoaks Kent TN13 1XR (GB).

- (81) Designated States (unless otherwise indicated, for every kind of national protection available): AE, AG, AL, AM, AO, AT, AU, AZ, BA, BB, BG, BH, BR, BW, BY, BZ, CA, CH, CL, CN, CO, CR, CU, CZ, DE, DK, DM, DO, DZ, EC, EE, EG, ES, FI, GB, GD, GE, GH, GM, GT, HN, HR, HU, ID, IL, IN, IS, JP, KE, KG, KM, KN, KP, KR, KZ, LA, LC, LK, LR, LS, LT, LU, LY, MA, MD, ME, MG, MK, MN, MW, MX, MY, MZ, NA, NG, NI, NO, NZ, OM, PE, PG, PH, PL, PT, QA, RO, RS, RU, RW, SC, SD, SE, SG, SK, SL, SM, ST, SV, SY, TH, TJ, TM, TN, TR, TT, TZ, UA, UG, US, UZ, VC, VN, ZA, ZM, ZW.
- (84) Designated States (unless otherwise indicated, for every kind of regional protection available): ARIPO (BW, GH, GM, KE, LR, LS, MW, MZ, NA, RW, SD, SL, SZ, TZ, UG, ZM, ZW), Eurasian (AM, AZ, BY, KG, KZ, RU, TJ, TM), European (AL, AT, BE, BG, CH, CY, CZ, DE, DK, EE, ES, FI, FR, GB, GR, HR, HU, IE, IS, IT, LT, LU, LV, MC, MK, MT, NL, NO, PL, PT, RO, RS, SE, SI, SK, SM, TR), OAPI (BF, BJ, CF, CG, CI, CM, GA, GN, GQ, GW, ML, MR, NE, SN, TD, TG).

Published:

- with international search report (Art. 21(3))
- before the expiration of the time limit for amending the claims and to be republished in the event of receipt of amendments (Rule 48.2(h))

(54) Title: STUD FOR FIXING INSULATION

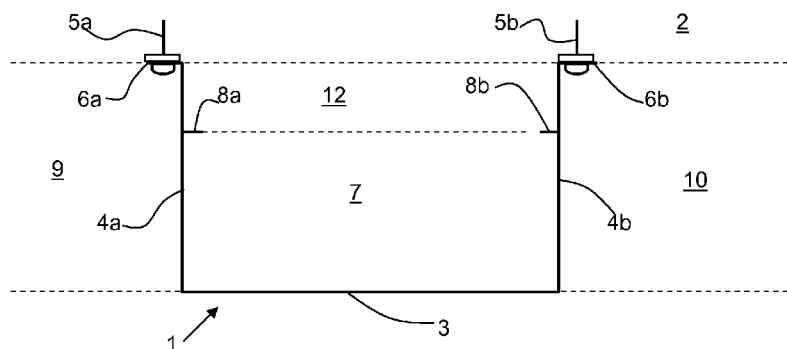

FIG. 1

(57) Abstract: A stud for fixing insulation to a substrate is disclosed. The stud comprises a front wall adapted to be spaced apart from the substrate, in use, so as to define a channel between the front wall and the substrate. The front wall has at least one aperture for access to the channel.



STUD FOR FIXING INSULATION

This invention relates to a stud for fixing insulation to a substrate.

5 It is widely acknowledged that a considerable quantity of the energy consumed in commercial and domestic premises for heating purposes is simply wasted due to poorly insulated buildings. To alleviate this problem, new buildings have been provided with insulation, for example in the form of cavity wall insulation and roof insulation, for some time. However, the quantity of insulation included
10 in a modern building is now far higher than that included even a few years ago.

Furthermore, there is a large stock of buildings (particularly residential housing) with rudimentary or non-existent insulation. For example, buildings built in the Victorian and Edwardian eras or before were typically constructed
15 with solid brick walls and have no particular insulation. More modern buildings make use of cavity wall construction, but no insulation is provided in the cavities. Whereas cavity wall insulation can be relatively straightforward to retro-fit without major disruption, upgrading the insulation to solid walls is typically very disruptive. This is because it must be applied internally requiring
20 complete internal refinishing (e.g. plastering) and redecoration and potentially the re-routing or adaptation of electrical and plumbing services.

Most methods for retro-fitting insulation to solid walls involve the fixing of studs to the interior of the walls and then installing sheet insulation between each of
25 the studs. The studs typically have recesses for retaining the edges of the sheet insulation. Plasterboard or another sheet building material may then be fixed over the insulation to provide a finished surface for decoration.

Aside from the disruption, there is a significant problem with this technique: it
30 becomes extremely difficult to access electrical and plumbing services buried in the walls for repairs of future alteration. This is because cables and pipes will typically be buried in the original wall structure beneath the sheet insulation

making them both difficult to locate and requiring significant damage to the sheet insulation to access them, which inevitably compromises the performance of the insulation.

5 In accordance with a first aspect of the invention, there is provide a stud for fixing insulation to a substrate, the stud comprising a front wall adapted to be spaced apart from the substrate, in use, so as to define a channel between the front wall and the substrate, wherein the front wall has at least one aperture for access to the channel, wherein the stud further comprises a layer of insulation
10 disposed in the channel, the thickness of the insulation being less than the distance by which the front wall is spaced apart from the substrate.

Hence, by providing a channel between the front wall and the substrate, it is possible to route services (and even straightforwardly re-route existing
15 services) in a well-defined location. Furthermore, the provision of apertures in the front wall allows access to cables and pipes in the channel without causing deterioration in the acoustic or thermal performance of the insulation. Various types of insulation may be used, including solid cell and acoustic insulation.

20 Typically, the at least one aperture will be sized to allow manual access to the channel.

In one embodiment, the at least one aperture comprises one or more apertures adapted to receive a pattress box, for example a pattress box made to comply
25 with BS4662:2006. The pattress box may be single or double gang. It may be of the type for use with plasterboard, having retaining lugs to secure the box to the plasterboard (although, in this case, the lugs will secure the box to the front wall of the stud).

30 The at least one aperture may comprise one or more apertures aligned with a respective pattress box integral with the front wall of the stud and disposed in the channel. In this case, an opening in an integral pattress box is aligned with

an aperture to allow an electrical fitting to be inserted through the aperture into the pattress box. The integral pattress box will normally be provided with threaded inserts to enable an electrical fitting to be secured to it with screws. The integral pattress box may be made to comply with BS4662:2006. The
5 pattress box may be single or double gang.

The at least one aperture may comprise a first aperture proximal a first end of the stud. In this case, the at least one aperture may also comprise a second aperture proximal a second end of the stud.

10

In another embodiment, the at least one aperture comprises a first notch formed in a first end of the stud. In this embodiment, the at least one aperture preferably comprises a second notch formed in a second end of the stud.

15

In a preferred embodiment, the at least one aperture comprises a first series of apertures spaced apart along the length of the stud, a first one of the first series of apertures being proximal a first end of the stud. In this preferred embodiment, the at least one aperture comprises a second series of apertures spaced apart along the length of the stud, a first one of the second series of
20 apertures being proximal a second end of the stud. The first one of the first and/or second series of apertures may be a notch in the first and/or second end of the stud.

25

The provision of apertures or notches at the ends of the stud allows cables and flexible pipes (e.g. push-fit plastic plumbing pipes) to be inserted into the channel at each end after the stud has been affixed to the substrate. It is also straightforward, using such apertures and notches, to reach and pull through cables offered into the channel from underneath a suspended floor below or a ceiling void above.

30

By providing a series of apertures as in the preferred embodiment, it is possible to cut the stud to a length to suit the ceiling height of the room in

which it is being installed and still ensure that a notch is at the cut end or an aperture is proximal the cut end if the cut falls between two of the series of apertures rather than across an aperture. Typically, the or each series of apertures will comprise 50mm apertures (for example, a series of four apertures) spaced apart by, for example, 30mm.

The stud comprises a layer of insulation disposed in the channel, the thickness of the insulation being less than the distance by which the front wall is spaced apart from the substrate. Preferably, this layer of insulation is disposed in the channel such that it is adjacent the front wall. The layer of insulation in the channel prevents the stud acting as a cold bridge, which would otherwise limit the performance of the installed insulation.

A particulate insulation material can be provided between the layer of insulation disposed in the channel and the substrate.

The layer of insulation can be provided with at least one cut-out corresponding with the at least one aperture. By providing at least one cut-out aligned with the at least one aperture, the installation of cables, pipes and electrical fittings into the apertures is eased. However, it is often preferable not to provide such cut-outs to prevent compromising the insulation in the region of apertures that are not used. Another possibility is to provide at least one portion of insulation aligned with the at least one aperture, the at least one portion of insulation with a perimeter that is weakened. The at least one portion may then be easily pushed out during installation if required.

The stud may further comprise at least one retaining flange to retain the layer of insulation in the channel.

The front wall is typically spaced apart from the substrate by a pair of opposed, spaced apart side walls. The side walls normally join the front wall at the corners of the stud. Together, the side walls define another two sides of the

channel. The back side of the channel (i.e. the side opposite the front wall) is normally left open against the substrate.

5 The retaining flanges are normally formed in the pair of opposed, spaced apart side walls.

At least one of the pair of side walls may be provided with a first side wall aperture proximal a first end of the stud, the first side wall aperture allowing access to the channel. In this case, at least one of the pair of side walls is normally provided with a second side wall aperture proximal a second end of the stud, the second side wall aperture allowing access to the channel.

15 At least one of the pair of side walls may be provided with a first side wall notch formed in a first end of the stud, the first side wall notch allowing access to the channel. In this case, at least one of the pair of side walls may be provided with a second side wall notch formed in a second end of the stud, the second side wall notch allowing access to the channel.

20 The side wall apertures or notches may be provided in both side walls at both ends. Thus, a total of four apertures or notches (two in each side wall) may be provided.

25 The front wall is preferably adapted to receive and hold fixings to enable sheet building materials to be affixed across the front wall. The fixings may be one or more of screws, nails or glue.

The adjacent studs will normally be fixed to the substrate at a spacing that conforms to the width of the sheets of insulation. This removes the requirement to cut the sheet insulation in most instances.

In accordance with a second aspect of the invention, there is provide a kit of parts comprising a plurality of studs according to the first aspect of the invention and fixings to secure each of the plurality of studs to a substrate.

5 Typically, the fixings are insulated fixings. This ensures that the fixings are thermally insulated from the substrate to prevent cold bridging.

The kit of parts may further comprise sole and/or head members for affixing to a floor and/or ceiling respectively and adapted to receive the ends of the
10 plurality of studs. This enables a free-standing structure to be erected if required and also allows the studs to be used to fit insulation against an uneven substrate.

The kit of parts may further comprise a removable skirting moulding and/or a
15 removable crown moulding for attachment to the plurality of studs. The skirting moulding and/or crown moulding may also or instead attach to the sole and/or head members, if used. The skirting moulding and crown moulding cover the apertures or notches in the front wall at the ends of the stud, but since they are removable allow easy access to the channel through the apertures or notches
20 in the future.

An embodiment of the invention will now be described with reference to the accompanying drawings, in which:

Figure 1 shows a cross-section through a stud according to the
25 invention;

Figure 2 shows a front elevation of a stud according to the invention;

Figure 3 shows a side elevation of a stud according to the invention;

Figure 4 shows a cross-section through a second example of a stud according to the invention; and

30 Figure 5 shows a cross-section through a third example of a stud according to the invention.

Figure 1 shows a stud 1 fitted to a wall 2. The stud comprises a front wall 3 and two side walls 4a, 4b. This stud 1 is affixed to the wall 2 by way of insulated fixings 5a, 5b, which pass through holes in flanges 6a, 6b at the ends of side walls 4a, 4b.

5

The front wall 3 and two side walls 4a, 4b, together define a channel, within which a layer of sheet insulation 7 is provided. The layer of insulation 7 runs the whole length of the stud 1. It is held in place in the channel by retaining flanges 8a, 8b. These are formed in side walls 4a, 4b and the layer of sheet
10 insulation 7 can be inserted into the channel from one end of the stud between the front wall 3 and the flanges 8a, 8b, which then hold the layer of insulation 7 in position in the channel adjacent the front wall 3.

With the stud 1 fixed to the wall 2 as shown in Figure 1, rigid sheets of
15 insulation 9, 10 may be slid between respective side walls 4a, 4b of the stud 1 and side walls of adjacent studs (not shown) back to the wall 2. By spacing the side walls of adjacent studs apart by the width of the sheet insulation, it is not necessary to cut the insulation to width, which speeds installation.

20 The stud is typically 80mm wide and typically has a depth of 44mm. The surface of the material from which it is made could be coated to reduce cold bridging and/or structural deterioration. For example, a ceramic coating can be used. The thickness of the material from which it is made is typically between 1mm and 2mm. These dimensions provide room to accommodate 40mm thick
25 sheets of insulation adjacent the side walls 4a, 4b. Another variant of the stud may be deeper, for example 54mm, to provide room to accommodate 50mm thick sheets of insulation, as may be required by modern building regulations. The retaining flanges 8a, 8b are typically about 5mm in length and spaced along the side wall so that the layer of insulation 7 may be 25mm thick. This
30 leaves a void 12 between the layer of insulation 7 and the wall 2 for use as a service duct or conduit.

Figures 2 and 3 show views of the front and side elevations of the stud 1. In the front wall 3, there are provided two cut-outs 13, 14 for receiving pattress boxes. The pattress boxes are pushed through the cut-outs 13, 14 in the front wall 3. Electrical cables may then be passed into the pattress boxes from the void 12 and electrical fittings (e.g. sockets or switches) coupled to the cables and screwed to the pattress boxes.

Typically, the pattress boxes will be of the type for use with plasterboard that have fixing lugs that clamp to the plasterboard; these lugs may instead be used to clamp to the front wall 3 and layer of insulation 7.

The layer of insulation 7 may either be provided with ready-made apertures aligned with the cut-outs 13, 14 or it may be cut away during installation. Alternatively, as mentioned above, the layer of insulation 7 may be provided with portions aligned with the cut-outs that have a weakened perimeter to enable it to be easily pushed out if access to the cut-out is required during installation.

In this embodiment, the pattress boxes are fitted as required during installation. In other embodiment, the pattress boxes may be integral with the front wall 3 of the stud 1.

The cut-out 13 is typically provided at a suitable height for a light switch, whereas the cut-out 14 is typically provided at a suitable height for a socket outlet. These heights may be dictated by local regulation, such as Part M of the Building Regulations or BS 7671 in the UK.

Also provided at the ends of the stud are notches 15, 16 in the front wall 3 and notches 17, 18 in the side wall 4a (similar notches are also provided in side wall 4b, but are not visible). These notches also allow access to the void 12. They are sized to allow a person to reach through into the void 12.

The notches 15, 16 provide a convenient location where an installer can pass cables and/or flexible pipes into the void 12 or pull cables through into the void 12 from a ceiling cavity above or from underneath a suspended floor below.

5 The notches 17, 18 allow cables and/or flexible pipes to be passed out of the side wall 4a and along to an adjacent stud, where they can enter the void of the adjacent stud through similar notches in the side wall. In this way, electrical and plumbing services can be easily fitted after installation of the insulation.

10 In the case where the stud 1 is too tall for a room in which it is to be installed then it can be cut down to size. An additional series of apertures 15a-15c is provided to take the place of notch 15 when the stud is cut down in size. When cut down, one of the apertures 15a-15c will generally be cut through to provide a notch at the top of the stud 1 or will lie close to the top of the stud 1.

15 Typically, the stud 1 will be provided as part of a kit of parts comprising a plurality of studs along with suitable insulated fixings 5a, 5b. Also provided in the kit could be a sole and/or head plate to which the studs can be fastened instead of wall 2 to allow for installation against uneven walls or for a free-
20 standing installation. The kit may also comprise the sheets of insulation 9, 10 and pattress boxes.

It may also comprise a skirting moulding and crown moulding. These can be affixed to the bottom and top respectively of the studs to conceal the notches
25 15 (or apertures 15a-15c as appropriate) and 16. They may be removable, for example by making use of clip fittings so that access to the notches 15 (or apertures 15a-15c as appropriate) and 16 can easily be gained in the future if repairs or modifications to the electrical and/or plumbing services are required. Thus, the services can be easily located again in the future with minimum
30 disruption and with no damage to the insulation. If the sole and/or head plate are used then the skirting and crown moulding may also be fixed to these (again, typically in a removable manner).

The design of the notches or openings along the front face can ensure that the stud can be cut to any exact room height whilst ensuring an access slot is available at ceiling level. Thus, the ceiling level access slots may extend in series from the top end of the stud down to a minimum ceiling height.

The stud material can be insulated from the wall to which it is fixed, for example by insulation between the flanges 6a, 6b and the wall. These can for example comprise adhesive strips, such as neoprene strips, and these prevent cold bridging to the stud.

The example shown is based on vertical studs. However, additional horizontal studs can be mounted between a pair of vertical studs. These can be used for example to provide a horizontal run of sockets, such as over a worktop. In this way, an insulated electrical conduit is provided.

In the example above, a void 12 is present at the back of the layer 7 of insulation, for the passage of cables. This void enables cables and pipework to be fed along the stud. This void can also be insulated, using particulate insulation material such as polystyrene beads. This provides additional insulation but still allows cables or pipes to be fed along the studs.

The insulation contained within the body of the stud can be simply fixed in place using adhesive or by using various mechanical fixings.

The example of Figure 1 has parallel side walls 4a,4b, which butt against the sides of the insulation material (both inside the stud and between the studs).

An alternative is shown in Figure 4, in which the side walls are splayed, so that they taper inwardly towards the wall 2. Thus, the spacing between studs is less away from the wall than against the wall, and the studs overhang the space created for the wall insulation sheets. The internal stud width is greater away from the wall than near the wall. The internal insulation sheets 7 can

then be cut to match the shape and they can be inserted from one end (i.e. the top) of the stud and remain in position without additional fixing, for example avoiding the need for the flanges 8a, 8b of Figure 1.

- 5 Figure 5 shows another variation where a corrugated side wall 4a,4b of the stud provides a fixing for the internal insulation. The corrugation functions as a friction grip created in the side wall of the stud. This can be used to hold both the internal stud insulation and the insulation between studs.
- 10 Figure 5 also shows a further measure to reduce thermal bridging by creating an offset fixing tab that minimises contact with the cold external wall substrate. In this way, the flanges 6a, 6b only need to be in close proximity to the wall along the locations where fixings are provided.
- 15 Figures 4 and 5 also show a slightly different design of fixing 5a, 5b having a double washer around the flange 6a, 6b which houses the screw fixings, in order to avoid cold bridging between the stud and the external wall. The double washer can also surround the shaft of the screws, so preventing any metal-metal contact or metal-wall contact. By raising the stud slightly away
- 20 from the wall using the washer on the wall side of the fixing, this also reduces the contact area for thermal conduction.

In the example of Figures 4 and 5, the wall insulation to be fitted between the studs can be cut in shape to match the stud shape. The wall insulation should

25 be sufficiently elastically deformable so that it can be inserted into position without needing to be slid in from the end (i.e. the top) of the stud, yet still remain held in place.

If the splay angle (Figure 4) or the corrugations (Figure 5) are small enough,

30 standard insulation sheets can again be used between the studs without cutting, and the shape mismatch also provides further retention of the wall insulation sheets, for example while outer wall boarding is applied.

The interior of the room can be finished by applying board material such as plasterboard over the studs and wall insulation. This can be fixed by self-tapping screws into the studs. The spacing of the studs is designed to be
5 suitable for the board material, for example spacing of 600mm or 450mm is typical for conventional timber stud walls finished with plasterboard.

Various other modifications will be apparent to those skilled in the art.

CLAIMS

1. A stud for fixing insulation to a substrate, the stud comprising a front wall adapted to be spaced apart from the substrate, in use, so as to define a channel between the front wall and the substrate, wherein the front wall has at least one aperture for access to the channel, wherein the stud further comprises a layer of insulation disposed in the channel, the thickness of the insulation being less than the distance by which the front wall is spaced apart from the substrate.
2. A stud according to claim 1, wherein the at least one aperture comprises one or more apertures adapted to receive a pattress box.
3. A stud according to claim 1 or claim 2, wherein the at least one aperture comprises one or more apertures aligned with a respective pattress box integral with the front wall of the stud and disposed in the channel.
4. A stud according to any of the preceding claims, wherein the at least one aperture comprises:
- a first aperture proximal a first end of the stud, and./or
 - a second aperture proximal a second end of the stud, and/or
 - a first notch formed in a first end of the stud and/or
 - a second notch formed in a second end of the stud.
5. A stud according to any of the preceding claims, wherein the at least one aperture comprises:
- a first series of apertures spaced apart along the length of the stud, a first one of the first series of apertures being proximal a first end of the stud, and/or
 - a second series of apertures spaced apart along the length of the stud, a first one of the second series of apertures being proximal a second end of the stud.

6. A stud according to any preceding claim, wherein the layer of insulation is provided with at least one cut-out corresponding with the at least one aperture.
- 5 7. A stud according to any preceding claim, further comprising at least one retaining flange to retain the layer of insulation in the channel.
8. A stud according to claim 7, wherein the front wall is spaced apart from the substrate by a pair of opposed, spaced apart side walls, and retaining flanges are formed in the pair of opposed, spaced apart side walls.
- 10 9. A stud according to claim 8, wherein at least one of the pair of side walls is provided with:
- a first side wall aperture proximal a first end of the stud, the first side wall aperture allowing access to the channel and/or
 - a second side wall aperture proximal a second end of the stud, the second side wall aperture allowing access to the channel.
10. A stud according to any of claims 7 to 9, wherein at least one of the pair of side walls is provided with:
- a first side wall notch formed in a first end of the stud, the first side wall notch allowing access to the channel and/or
 - a second side wall notch formed in a second end of the stud, the second side wall notch allowing access to the channel.
- 25 11. A stud according to any preceding claim, further comprising a particulate insulation material between the layer of insulation disposed in the channel and the substrate.
- 30 12. A kit of parts comprising a plurality of studs according to any of the preceding claims and fixings to secure each of the plurality of studs to a substrate.

13. A kit of parts according to claim 12, wherein the fixings are insulated fixings.
- 5 14. A kit of parts according to claim 12 or claim 13, further comprising sole and/or head members for affixing to a floor and/or ceiling respectively and adapted to receive the ends of the plurality of studs.
- 10 15. A kit of parts according to any of claims 12 to 14, further comprising a removable skirting moulding and/or a removable crown moulding for attachment to the plurality of studs.

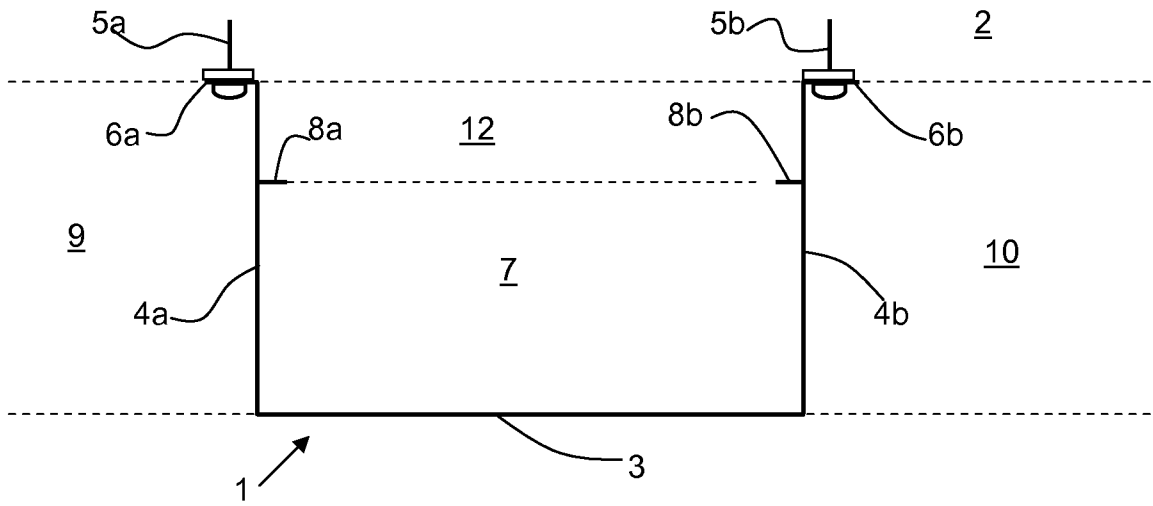

FIG. 1

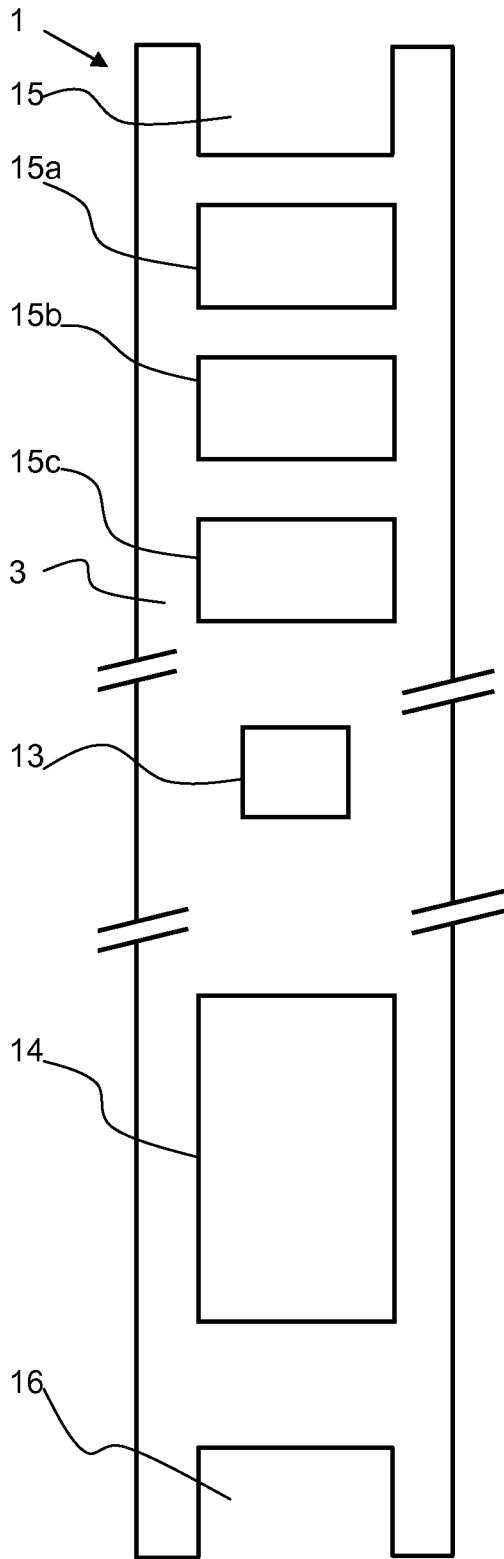

FIG. 2

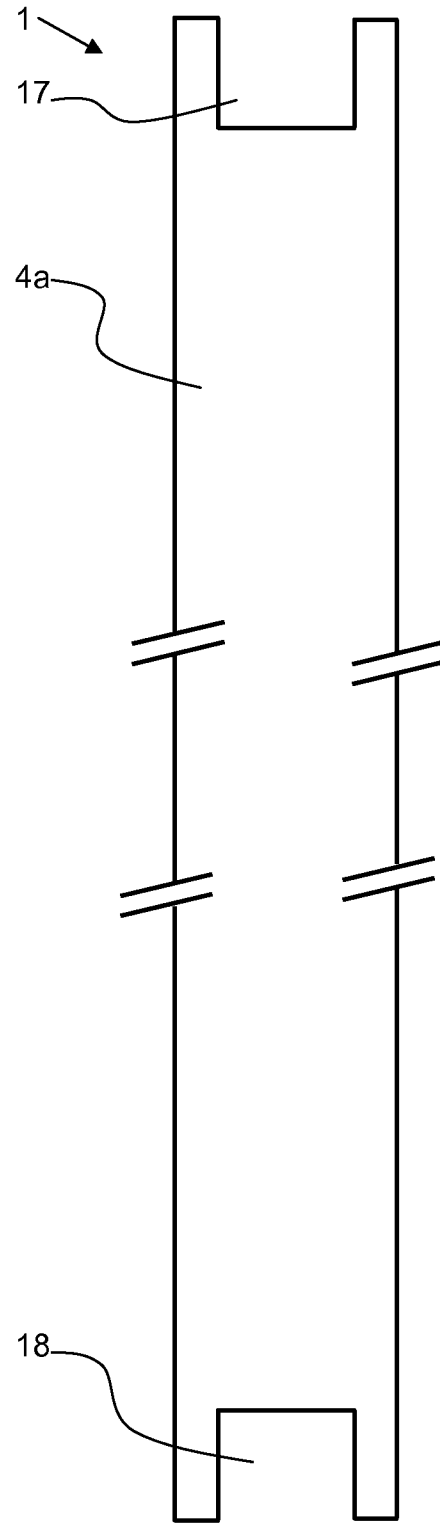

FIG. 3

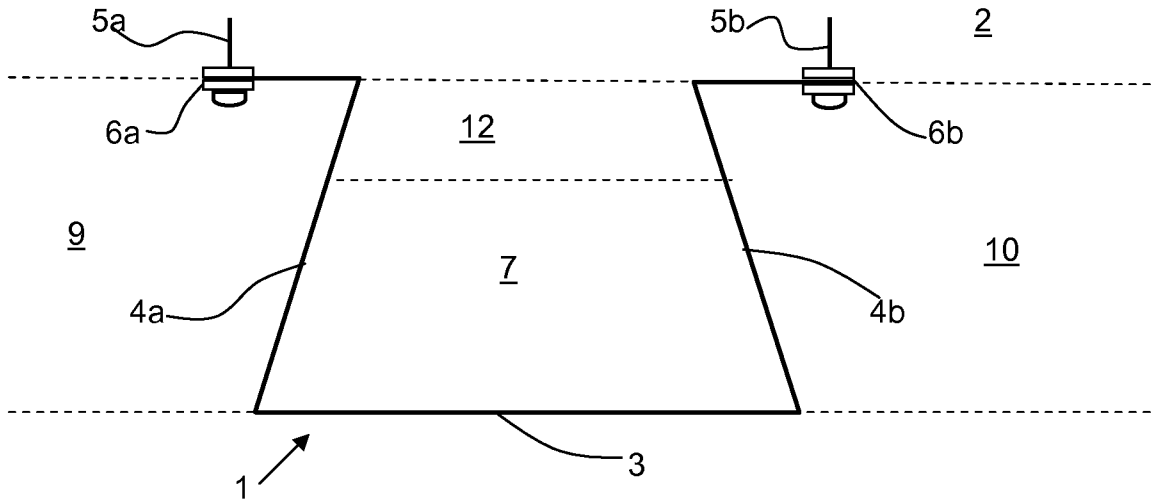

FIG. 4

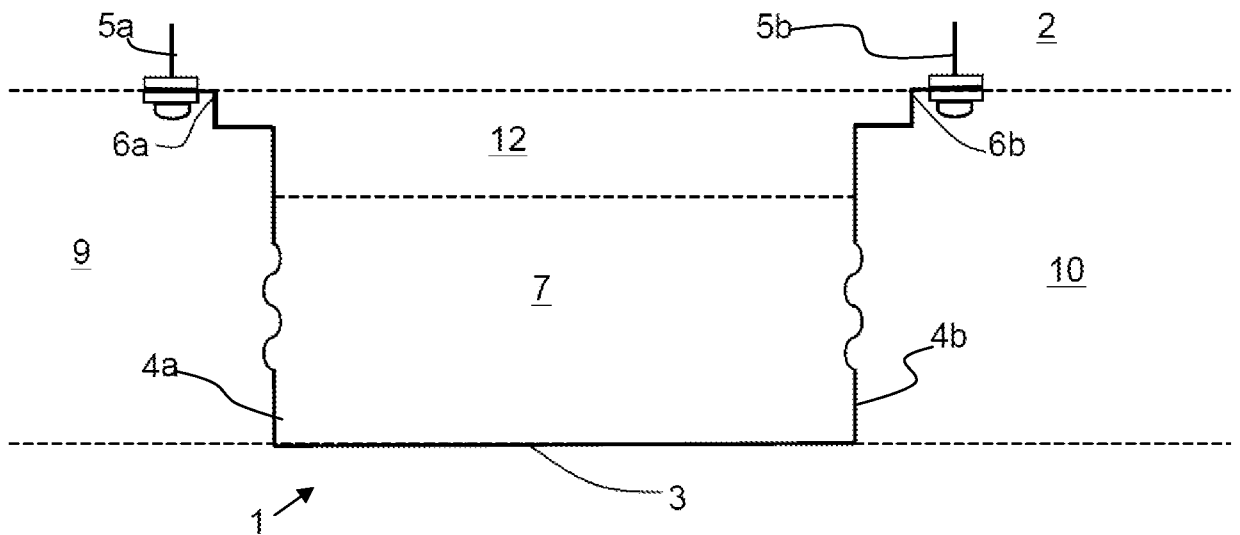

FIG. 5

INTERNATIONAL SEARCH REPORT

International application No
PCT/GB2012/051423

A. CLASSIFICATION OF SUBJECT MATTER
 INV. H02G1/00 H02G3/04 H02G3/32
 ADD.

According to International Patent Classification (IPC) or to both national classification and IPC

B. FIELDS SEARCHED
 Minimum documentation searched (classification system followed by classification symbols)
 H02G E04C E04B

Documentation searched other than minimum documentation to the extent that such documents are included in the fields searched

Electronic data base consulted during the international search (name of data base and, where practicable, search terms used)
 EPO-Internal

C. DOCUMENTS CONSIDERED TO BE RELEVANT

Category*	Citation of document, with indication, where appropriate, of the relevant passages	Relevant to claim No.
A	GB 1 488 752 A (LARSSEN J) 12 October 1977 (1977-10-12) page 2, line 1 - line 41; figures -----	1,11,12
A	EP 1 124 023 A2 (RICHTER SYSTEM GMBH & CO KG [DE]) 16 August 2001 (2001-08-16) column 3, line 53 - column 4, line 7; figures 2,4 -----	1
A	WO 99/63176 A1 (OWENS CORNING FIBERGLASS CORP [US]; BERDAN CLARKE II [US]; BRIEN BERNI) 9 December 1999 (1999-12-09) claims; figures -----	1

Further documents are listed in the continuation of Box C. See patent family annex.

* Special categories of cited documents :

<p>"A" document defining the general state of the art which is not considered to be of particular relevance</p> <p>"E" earlier application or patent but published on or after the international filing date</p> <p>"L" document which may throw doubts on priority claim(s) or which is cited to establish the publication date of another citation or other special reason (as specified)</p> <p>"O" document referring to an oral disclosure, use, exhibition or other means</p> <p>"P" document published prior to the international filing date but later than the priority date claimed</p>	<p>"T" later document published after the international filing date or priority date and not in conflict with the application but cited to understand the principle or theory underlying the invention</p> <p>"X" document of particular relevance; the claimed invention cannot be considered novel or cannot be considered to involve an inventive step when the document is taken alone</p> <p>"Y" document of particular relevance; the claimed invention cannot be considered to involve an inventive step when the document is combined with one or more other such documents, such combination being obvious to a person skilled in the art</p> <p>"&" document member of the same patent family</p>
---	---

Date of the actual completion of the international search	Date of mailing of the international search report
26 November 2012	04/12/2012

Name and mailing address of the ISA/ European Patent Office, P.B. 5818 Patentlaan 2 NL - 2280 HV Rijswijk Tel. (+31-70) 340-2040, Fax: (+31-70) 340-3016	Authorized officer <p style="text-align: center;">Rieutort, Alain</p>
--	--

INTERNATIONAL SEARCH REPORT

Information on patent family members

International application No PCT/GB2012/051423

Patent document cited in search report	Publication date	Publication date	Patent family member(s)	Publication date
GB 1488752	A	12-10-1977	DE 2520255 A1	20-11-1975
			FI 751336 A	08-11-1975
			GB 1488752 A	12-10-1977
			SE 385603 B	12-07-1976
			SE 7406066 A	10-11-1975

EP 1124023	A2	16-08-2001	NONE	

WO 9963176	A1	09-12-1999	AU 4673899 A	20-12-1999
			CA 2332445 A1	09-12-1999
			EP 1084310 A1	21-03-2001
			US 6128884 A	10-10-2000
			WO 9963176 A1	09-12-1999
