

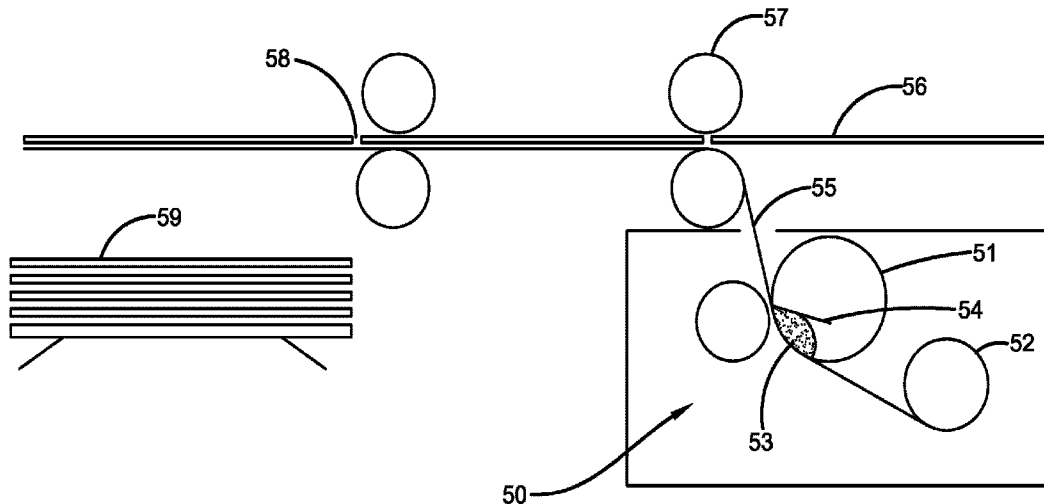

(86) **Date de dépôt PCT/PCT Filing Date:** 2016/11/03
 (87) **Date publication PCT/PCT Publication Date:** 2017/05/11
 (45) **Date de délivrance/Issue Date:** 2023/11/21
 (85) **Entrée phase nationale/National Entry:** 2018/05/17
 (86) **N° demande PCT/PCT Application No.:** US 2016/060259
 (87) **N° publication PCT/PCT Publication No.:** 2017/079392
 (30) **Priorité/Priority:** 2015/11/06 (US62/251,893)

(51) **Cl.Int./Int.Cl. E01F 9/524** (2016.01),
B32B 27/00 (2006.01), **G02B 5/122** (2006.01)
 (72) **Inventeur/Inventor:**
PRICONE, ROBERT M., US
 (73) **Propriétaire/Owner:**
10X TECHNOLOGY LLC, US
 (74) **Agent:** SMART & BIGGAR LP

(54) **Titre : PANNEAU DE SIGNALISATION RETROREFLECHISSANT ET PROCEDE ET APPAREIL POUR SA FABRICATION**
 (54) **Title: RETROREFLECTIVE TRAFFIC SIGN AND PROCESS AND APPARATUS FOR MANUFACTURING SAME**



(57) **Abrégé/Abstract:**

A method, apparatus for making, and a retroreflective traffic sign consists of a polymeric film having a front face and a rear face, wherein the rear face has a pattern of microprismatic retroreflective elements integrally formed as part of said film; a pattern of cell walls formed of an adhesive-containing polymer defining cells in which the microprismatic retroreflective elements are in the cells; and a substrate is adhered directly to the cell walls formed of the adhesive-containing polymer while leaving an air gap between the microprismatic retroreflective elements and the substrate in the cells.

(12) INTERNATIONAL APPLICATION PUBLISHED UNDER THE PATENT COOPERATION TREATY (PCT)

(19) World Intellectual Property
Organization
International Bureau(10) International Publication Number
WO 2017/079392 A1(43) International Publication Date
11 May 2017 (11.05.2017)

(51) International Patent Classification:

E01F 9/524 (2016.01) *G02B 5/122* (2006.01)
B32B 27/00 (2006.01)

(21) International Application Number:

PCT/US2016/060259

(22) International Filing Date:

3 November 2016 (03.11.2016)

(25) Filing Language:

English

(26) Publication Language:

English

(30) Priority Data:

62/251,893 6 November 2015 (06.11.2015) US

(71) Applicant: **10X TECHNOLOGY LLC** [US/US]; 2105 Tempel Drive, Libertyville, IL 60048 (US).(72) Inventor: **PRICONE, Robert, M.**; 31175 N. Bob-O-Link Lane, Libertyville, IL 60048 (US).(74) Agent: **LEWIS, Nathan T.**; Medley, Behrens & Lewis, LLC, 6100 Rockside Woods Blvd., Suite 440, Independence, Ohio 44131 (US).

(81) Designated States (unless otherwise indicated, for every kind of national protection available): AE, AG, AL, AM, AO, AT, AU, AZ, BA, BB, BG, BH, BN, BR, BW, BY,

BZ, CA, CH, CL, CN, CO, CR, CU, CZ, DE, DJ, DK, DM, DO, DZ, EC, EE, EG, ES, FI, GB, GD, GE, GH, GM, GT, HN, HR, HU, ID, IL, IN, IR, IS, JP, KE, KG, KN, KP, KR, KW, KZ, LA, LC, LK, LR, LS, LU, LY, MA, MD, ME, MG, MK, MN, MW, MX, MY, MZ, NA, NG, NI, NO, NZ, OM, PA, PE, PG, PH, PL, PT, QA, RO, RS, RU, RW, SA, SC, SD, SE, SG, SK, SL, SM, ST, SV, SY, TH, TJ, TM, TN, TR, TT, TZ, UA, UG, US, UZ, VC, VN, ZA, ZM, ZW.

(84) Designated States (unless otherwise indicated, for every kind of regional protection available): ARIPO (BW, GH, GM, KE, LR, LS, MW, MZ, NA, RW, SD, SL, ST, SZ, TZ, UG, ZM, ZW), Eurasian (AM, AZ, BY, KG, KZ, RU, TJ, TM), European (AL, AT, BE, BG, CH, CY, CZ, DE, DK, EE, ES, FI, FR, GB, GR, HR, HU, IE, IS, IT, LT, LU, LV, MC, MK, MT, NL, NO, PL, PT, RO, RS, SE, SI, SK, SM, TR), OAPI (BF, BJ, CF, CG, CI, CM, GA, GN, GQ, GW, KM, ML, MR, NE, SN, TD, TG).

Published:

- with international search report (Art. 21(3))
- before the expiration of the time limit for amending the claims and to be republished in the event of receipt of amendments (Rule 48.2(h))

(54) Title: RETROREFLECTIVE TRAFFIC SIGN AND PROCESS AND APPARATUS FOR MANUFACTURING SAME

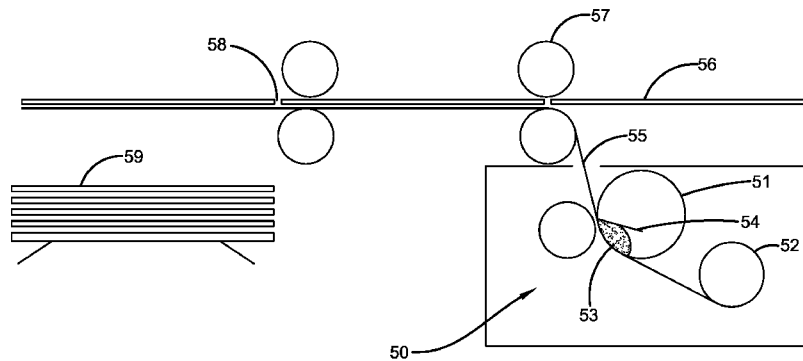

FIG. 4

(57) Abstract: A method, apparatus for making, and a retroreflective traffic sign consists of a polymeric film having a front face and a rear face, wherein the rear face has a pattern of microprismatic retroreflective elements integrally formed as part of said film; a pattern of cell walls formed of an adhesive-containing polymer defining cells in which the microprismatic retroreflective elements are in the cells; and a substrate is adhered directly to the cell walls formed of the adhesive-containing polymer while leaving an air gap between the microprismatic retroreflective elements and the substrate in the cells.

WO 2017/079392 A1

RETROREFLECTIVE TRAFFIC SIGN AND PROCESS AND APPARATUS FOR MANUFACTURING SAME

TECHNICAL FIELD

[0002] This application relates to a new retroreflective traffic sign and process and apparatus for directly combining polymeric retroreflective microprismatic thin film to an aluminum backing to produce a finished traffic sign, and, more particularly, a process and apparatus for making traffic signs that are less expensive and just as functional as the current method of manufacturing such signs.

BACKGROUND

[0003] Processes and apparatus for embossing precision optical patterns, such as microcubes, or prisms, in a thin film resinous sheet or laminate, are known as referenced in U.S. Patents Nos. 4,486,363; 4,478,769; 4,601,861; 5,213,872; 6,015,214, and more recently 6,908,295.

In the production of such synthetic resin optical sheeting film, highly precise embossing (generally exceeding the capabilities of current micromolding processing techniques for synthetic resins), is required because the geometric accuracy of the optical prismatic elements determines the film's optical performance. The above referenced patents disclose particular methods and apparatus

for continuously embossing a repeating retro-reflective microprismatic pattern of fine or precise optical quality and detail on one surface of a transparent and thin thermoplastic film to form the surface of the film into the desired retroreflective microstructured pattern.

[0004] This application relates to significant improvements to the method and apparatus of prior patent, U.S. 4,618,518, issued June 21, 1986, of which the current inventor is a named co-inventor thereof.

[0005] To manufacture current traffic signs, the thin retroreflective microprismatic pattern in thermoplastic film is then combined with a protective backing layer behind the microprismatic elements, and then there is applied an additional pressure sensitive adhesive and a release liner. Subsequently the release liner is removed and the adhesively backed film is then applied to an underlying aluminum or other material substrate. This combination of materials is known as reflective sheeting, in which the film is produced in rolls in various specified colors and then laminated to the aluminum or other material panels to produce the primary components for traffic signs. Lettering and symbols can be printed or laminated as film on the front film surface to provide text or other instructions to a driver. Prior to corner cube prisms, products such as those consisting of glass bead film, known as engineer grade, and high-intensity films have been used for decades. More recently the improved versions use micro prismatic optics formed on the reflective film, which is more efficient and capable of a diverse range of reflectivity that is beneficial to the driver at night. Nonetheless, the retroreflective sheeting products currently produced, as manufactured by numerous companies, are produced with the backing layer, the adhesive layer and the release liner and then

shipped to sign shops that fabricate the signs where the film is then laminated to aluminum or other material panels using the pressure sensitive adhesive. This technique currently now is, and has been universally used for decades as the primary method of manufacturing retroreflective traffic signs. There are several companies that manufacture the retroreflective sheeting film and many companies that provide the aluminum panels. Sign makers purchase the reflective sheeting with the back layer, adhesive layer and release liner from one source and the aluminum panels are purchased from another source and then the sign shops combine the two components.

SUMMARY

[0006] It is one feature of the present disclosure to provide a new retroreflective traffic sign consisting of a polymeric film having a front face and a rear face having an optical pattern of microprismatic retroreflective elements integrally formed as part of such film, a pattern of walls formed of an adhesive containing polymer defining cells in which microprismatic elements are in the area defined by the cell walls, and an aluminum (or other material) substrate is adhered directly to such cell wall polymer.

[0007] It is another feature of the disclosure to provide a method for forming a retroreflective traffic sign, comprising passing a film having retroreflective elements on one side thereof past a station for applying a viscous polymer containing an adhesive in a pattern defining cell walls around areas of the retroreflective elements; then applying the film having the viscous polymer directly to an aluminum substrate and laminating the film to the substrate via the cell walls (meaning using the cell walls as the adhesive for lamination) while leaving the remaining retroreflective elements surrounded by air, and allowing the viscous material to cure while adhered to the substrate. It is still a further

feature of the disclosure to provide apparatus for producing a retroreflective traffic sign, including means for feeding a thin film having retroreflective elements on one side past a rotary screen having a pattern defining closed areas and open areas that will allow passage of a viscous adhesive containing polymer through the open areas of the screen onto the side of the film having the retroreflective elements to provide walls defining cells surrounding predetermined areas of the retroreflective elements; means for feeding the film with the viscous polymer cell walls onto an aluminum substrate, and means for laminating the film to such substrate to provide a traffic sign needing only the proper directional materials (lettering or symbols) to be applied to the front face of the film.

[0008] The technology presented herein is for a new composite traffic sign, and a process that permits one to laminate only a thin, retroreflective microprismatic film layer directly to large aluminum panels, without the backcoating, adhesive layer and release liner as currently required. The combined materials now represent a finished fully functional traffic sign when cut or punched into the finished sign shape, and only the lettering or symbols need to be applied as is currently done.

[0009] In the case of an overhead guide sign, green or blue retroreflective microprismatic film is laminated directly to large aluminum panels, typically 4' x 8' in size (32 square feet), which are then joined together by spot welding or riveting to produce the entire larger background of the sign. Only the legend, text or symbols would have to be applied to the front face of the film. This product would be sold into sign shops, eliminating the need for one source of retroreflective sheeting and another source of aluminum and then combining the two components. It also eliminates the cost of the

protective backing of the micro prismatic layer as well as the pressure sensitive adhesive and release liner. Therefore, in this new traffic sign product, the overall material costs are reduced, and even more importantly, the cost of labor to laminate the retroreflective sheeting component to the aluminum, is eliminated, thereby significantly reducing the total cost to the sign fabricator.

[0010] This could be done with all the primary colors for retroreflective sheeting, so when combined with the aluminum component this will allow the sign manufacturer to provide virtually every traffic sign shape and color. Because there are many types of microprismatic reflective sheeting (provided by different optics) identified in the ASTM D4956-13 specifications, one need only provide a thin microprismatic thin-film component in compliance with each specification, each to be laminated directly to an aluminum panel, thereby satisfying all of the industry needs. Sheets of the micro prismatic film layer laminated to aluminum panels can be shipped as large sheets stacked on skids to sign fabricators who can cut the panels to size and add the specific text and symbols as required. An embodiment of the product disclosed herein significantly reduces the overall cost to the sign fabricators, eliminating much, of their labor other than applying the specific front message on the sign.

[0011] In an embodiment, a retroreflective traffic sign consists of a polymeric film having a front face and a rear face, wherein the rear face has a pattern of microprismatic retroreflective elements integrally formed as part of said film; a pattern of cell walls formed of an adhesive-containing polymer defining cells in which the microprismatic retroreflective elements are in the cells; and a substrate is adhered directly to the cell

walls formed of the adhesive-containing polymer while leaving an air gap between the microprismatic retroreflective elements and the substrate in the cells.

[0012] In an embodiment, a method for forming a retroreflective traffic sign, comprises: passing a film having retroreflective elements on one side thereof past a station; at the station, applying a viscous polymer containing an adhesive in a pattern defining cell walls around areas of the retroreflective elements; applying a side of the film having the cell walls directly to a substrate; laminating the film to the substrate via the cell walls; wherein the side of the film having the cell walls, the cell walls, and the substrate define an air gap; and allowing the viscous material to cure while the film is adhered to said substrate.

[0013] In an embodiment, an apparatus for producing a retroreflective traffic sign, comprises: means for feeding a thin film having retroreflective elements on one side of the film past a rotary screen having a pattern defining closed areas and open areas that will allow passage of a viscous adhesive-containing polymer through the open areas of the screen onto the side of the film having the retroreflective elements thereon to provide walls defining cells surrounding predetermined areas of the retroreflective elements; means for feeding the film with the viscous polymer cell walls onto a substrate; and means for laminating the film to the substrate via said viscous polymer, wherein the traffic sign optionally includes drive related directions on the front face of the film.

BRIEF DESCRIPTION OF THE DRAWINGS

[0014] FIG. 1 is a perspective view of a section of a traffic sign (without front face printing) produced in accordance with the present invention;

[0015] FIG. 2 is a partial enlarged sectional elevational view representative of the traffic sign panel of the current invention;

[0016] FIG. 3 is a plan view representative of one cell area of a type of microprisms that may be used in the traffic sign;

[0017] FIG. 4 is a schematic view of the apparatus and which shows the process of forming the novel traffic sign;

[0018] FIG. 5 is representative of a section of the rotary screen used to print the cell walls of the sign; and

[0019] FIG. 6 is a greatly enlarged representative area of one size of cell defined by cell walls and encompassing a predetermined area of microprismatic elements.

DETAILED DESCRIPTION

[0020] Referring now to Fig. 1, the retroreflective sign panel, designated 25, includes a microprismatic retroreflective film 26 that is a two layer thermoplastic material manufactured in accordance with processes disclosed herein. As herein shown, the microprismatic retroreflective film 26 has a front layer 27 with an obverse surface 28 and the rear or reverse surface 29 upon which is formed (preferably by embossing) a microprismatic type retroreflective pattern as illustrated in FIG. 3. For purposes hereof, the microprisms (often referred to as cube-corners or corner-cubes) may consist of different arrays of different elements, but the formation of the new traffic sign may include any of such precise microprisms. The thermoplastic web or microprismatic retroreflective film 26 may be on the order of about 0.006 inch (0.15 mm) in thickness, such as, for example, in the range of 0.005 to 0.01 inches (0.127 mm to 0.254 mm), or 0.006 to 0.009 (0.1524 mm to 0.2286 mm), depending on the depth of the prisms.

[0021] Referring to FIG. 3, the numeral 10 indicates generally a segment of a microprismatic type reflective thermoplastic web used in forming the laminate of the present invention. As seen in FIG. 3 there is depicted the rear surface of a portion of flexible retroreflective film 12 fashioned from transparent thermoplastic material in web form which has formed thereon, preferably by embossing, a retroreflective and repeating pattern of microprismatic reflector elements characterized by cube faces 14, 16 and 18. In a preferred aspect of the invention, the film 12 is formed from an impact modified acrylic having UV inhibitors or absorbers added thereto, and which, prior to embossing, had parallel front and back surfaces and was initially on the order of about 0.15 mm (0.006 inches) thick. One such material is known as Plexiglas DR 101, sold by Arkema Company.

[0022] The microprismatic pattern formed on sheeting 12 is formed in an optically precise finely detailed pattern as known in the art. For example, as seen in FIG.2, the cube apex to groove of the microprismatic pattern as embossed into the film 12 (or as depicted as 26 in FIG 1) may be on the order of 0.8 mm (0.00338 inch) (dimension X). As shown at dimension Y in FIG 3 the prisms formed on sheet 12 may be spaced apart (meaning the distance Y is the distance across the prism in its greatest dimension) by a distance on the order of about 0.18 mm (0.0072 inch), such as 0.1 mm to 0.25 mm, or 0.15 mm to 0.23 mm, for the depth as shown at X. While the prism pattern shown in FIGS 1 and 3 illustrates prisms each formed with their optical axis normal to the front face of film 12, it is to be understood that other versions and patterns may also be utilized as forming the retroreflective web of the laminate of the present invention. In an embodiment, the X dimension may, for example, be about 0.05 mm to about 2 mm, or

0.1 mm to 0.25 mm, or 0.15 mm to 0.23 mm, the precise value to be dependent on the depth of the prisms which in part relates to the optical design selected. In an embodiment, the Y dimension may vary depending on the optical design of the prisms.

[0023] Retroreflectivity is achieved by microprismatic type reflector elements primarily through the principle of total internal reflection. In order to best achieve this it is known in the art to provide an air gap between the prism apices and any substrate to which the film is attached. Thus for example, as shown in US Patent 5,930,041, which is incorporated herein by reference, cell walls around an array of microprisms are provided by sonic welding of a backing layer to the film; later an adhesive layer and a release liner are provided to the roll of welded film.

[0024] In accord with the present technology, no backing layer is needed to provide the air gap. In this case, a cell wall structure, generally at 42 (FIG 1) provides discrete cells providing an air gap 34 between the microprismatic elements and an aluminum (or other material) substrate 32. For illustrative purposes only, the air gap in FIGS 1 and 2 are represented by a dotted arrangement, it being understood that in actual formation there is no material in that space. In an embodiment, the cell walls formed from adhesive may be disposed directly on the retroreflective microprismatic elements. The pattern in the area defined by the resulting walls of the cells may vary depending upon the cell size and pattern area required for the amount of retroreflection needed. Typical examples of the pattern cell walls range from about 0.010 inch to about 0.020 inch (0.254 mm to 0.508 mm) in thickness (width), such as 0.3 mm to 0.5 mm, or 0.35 mm to 0.45 mm. The cell wall width will depend upon both the nature of the prism design and the amount of reflectivity required to meet the specifications.

[0025] Other possible alternatives to aluminum for the substrate are, sheet steel that has been powder coated or galvanized for outdoor applications, polymer composites such as layers of PEEK, polycarbonate, PMMA, or other combinations that would provide strength and rigidity, including recycled polymer combinations, recycled rubber-tire composites and other possible layers such as carbon fiber, fiberglass and wood composites that have been treated for outdoor use.

[0026] Referring now to FIG. 5 and 6, the numeral 40 indicates generally such a selected pattern. Each cell wall 42 represents polymeric adhesive (or sealant) on the reverse (prismatic side) surface of the thermoplastic film (Fig. 2, reference 26). Each cell with diamond shaped area 44 circumscribes an area that has a volume in the composite which comprises an air gap (Fig. 2, reference 34) between the microprismatic corner cube surfaces (FIG. 1, reference 29) and the aluminum backing 32. While this is described as film (e.g. as shown in FIG 6), it is also representative of a section of the screen 51 (FIG 4) through which a viscous polymer is applied, as hereinafter described. As best seen in FIG 6, the actual percentage of area in which there is an air gap over the prismatic elements, is determined by the thickness or width of each cell wall 42, and the pattern selected for the air cell 44.

[0027] In the embodiment herein illustrated, each discrete air cell 44 has an area characterized by the dimension E in FIGS 2 and 6 (since Fig. 6 shows a square air cell 44 the area of the air cell 44 is E squared). The dimension D is the thickness of the cell wall 42. As hereinabove described, the percentage of surface area available for retroreflectivity may be adjusted by changing the dimensions D and E as shown in FIGS 2 and 6. Where, for example, as mentioned above, D is, for example, 0.015 inch (0.381

mm) and the dimension E is for example 0.200 inch (5.08 mm), the effective surface area of microprismatic elements available for retroreflection is about 84%. If dimension D is 0.027 inch (0.685 mm) and dimension E is 0.138 inch (3.50 mm), approximately 70% of the total surface of the resulting composite preserves retroreflective characteristics. With the dimension D of 0.029 inch (0.736 mm) and a dimension E of 0.096 inch (2.43 mm) than, approximately 55% of the total surface of the resulting composite retains retroreflective properties. In a preferred embodiment, dimension D is 0.030 inch (0.762 mm) and dimension E is 0.170 inch (4.31 mm) to give an effective area of reflection of about 73%.

[0028] In an embodiment, the dimension E may range from for example, about 0.01 to about 1 inch, about 0.1 to about 0.5 inches, or about 0.15 to about 0.35 inches. In an embodiment the effective area of reflection is about 50% to about 99%, such as 55% to about 90%, or about 60% to about 85%.

[0029] FIG. 4 shows, in schematic form, a preferred arrangement of equipment and sequence of operations to produce the retroreflective traffic sign composite of the type shown in FIG. 1.

[0030] The application of the adhesive cell wall 53 that is a viscous adhesive containing polymer (for purposes hereof, also generally referred to as a sealant), is applied directly via blade 54 to the microprismatic side of the microprismatic film 55 and then laminated at 57 to aluminum panels 56. The blade 54 is a flexible metal blade that is pushed against the metal screen to apply the adhesive containing polymer to the microprismatic film through pores in the screen. The viscous adhesive containing polymer, may, for

example, have a viscosity of 250,000 cP to 100,000,000 cP, such as 1,000,000 to 8,000,000, or 3,000,000 to 5,000,000.

[0031] In an embodiment, the adhesive cell wall sealant 53 is applied by a rotary screen drum 51 in a diamond pattern with a cell size in the range of from about 0.096 inch (2.43 mm) to 0.300 inch (7.62 mm) and a wall width from about 0.010 inch (0.25 mm) to about 0.050 inch (1.27 mm). Variations in shape of the cells, the pattern repeat of the cells, and width of the cell walls 42 may be accomplished by changing the printing screen used on the screen printing drum 51. Also, the width of the film fed from roll 52 may be of various sizes, and the printing screens used will be of a compatible width.

[0032] Several preferred polymer formulations for the viscous adhesive cell wall sealant 53 have been identified that can be printed to form cell walls 42 that have adhesion to both the microprismatic retroreflective film (Fig. 1, reference 26) and the aluminum (or other metal) substrate 56 (the finished panel designates the substrate as numeral 32 in FIGS 1 and 2).

[0033] The preferred material to print the adhesive cell wall sealant 53 that will have adhesion to the microprismatic retroreflective film 26 is a silicone rubber adhesive. Silicone rubber is an elastomer (rubber-like material) composed of silicone—itsself a polymer—containing silicon together with carbon, hydrogen, and oxygen. Silicone rubbers are widely used in industry, and there are multiple formulations. Silicone rubbers are often one- or two-part polymers, and may contain fillers to improve properties or reduce cost. Silicone rubber is generally non-reactive, stable, and resistant to extreme environments and temperatures from -55 °C to +300 °C while still maintaining its useful properties.

[0034] Due to these properties and its ease of manufacturing and shaping, silicone rubber can be found in a wide variety of products, including: automotive applications; cooking, baking, and food storage products; apparel such as undergarments, sportswear, and footwear; electronics; medical devices and implants; and in home repair and hardware with products such as silicone sealants.

[0035] Typical physical properties for silicone rubber adhesives are as shown in the table below:

Mechanical properties

Hardness, shore A	10–90
Tensile strength	~11 N/mm ²
Elongation at break	100–1100%
Maximum operational temperature	+300 °C
Minimum operational temperature	-120 °C

[0036] One example of a silicone rubber sealant that can be printed to form cell walls 42 is a product such as Master Sil 713, available from MASTERBOND a low viscosity silicone adhesive/sealant that cures within an hour. It has a viscosity of 3,000 cps and exhibits a tensile strength of 125 psi and more than 200% elongation. Hardness is Shore A 30.

[0037] Alternatively, other adhesives that suitably function to bond the thin polymer reflective layer to the rigid backing sheet may be used that have the same or similar properties as the silicone adhesive mentioned above. One alternative to silicone is a water-borne polymeric systems consisting of acrylic/urethane copolymers.

[0038] High elongation at break, e.g., 100% to 1100%, or 200% to 500%, and low Shore A hardness, e.g., 10–90, or 20 to 60 are physical requirements for the sign, because an aspect of the solvent used to print the cell walls that bonds the reflective film to the aluminum backing is that it be flexible enough to compensate for the difference in coefficient of thermal expansion between the thermoplastic DR 101 reflective film, and the aluminum backing. The degree of flexibility, and the height and thickness of the cell wall required can be calculated allowing the cell wall to flex so that retroreflective film layer does not fracture during expansion or contraction of the aluminum backing.

[0039] In an embodiment, all of the properties of this construction will meet the requirements as specified in the test procedures for reflective sheeting in ASTM D4956 – 13, Standard Specification for Retroreflective Sheeting for Traffic Control.

[0040] As an example, paragraphs 6.9 and 7.5 of such Specification recite:

“6.9 Adhesion—When tested in accordance with 7.5, the adhesive backing of the retroreflective sheeting shall produce a bond that will support a 1 3/4-lb (0.79-kg) weight for adhesive classes 1, 2, and 3 or a 1-lb (0.45-kg) weight for adhesive class 4 for 5 min, without the bond peeling for a distance of more than 2 in. (51 mm).”

[0041] In this case because a separate adhesive backing is not used, adhesion is measured between the polymer microprismatic layer 29 and the aluminum substrate 32.

[0042] A preferred form of the apparatus to apply the adhesive cell wall sealant 53 is application station 50 consisting of a rotary screen printer manufactured by Stork

Bragant BV of Boxmeer, Holland, of the type having a drum with an electroformed mesh screen 51. The screen 51 will have desired openings defining cell walls 42 and the areas 45 on the screen (FIG 5) will be solid on the screen to define the open areas 44 for the air gaps (FIG 6).

[0043] In an embodiment, the microprismatic retroreflective film 26 is provided on a roll 52.

[0044] The adhesive cell wall sealant 53 is pushed through the rotary screen 51 using a flexible stainless steel blade 54, printing the adhesive cell wall sealant as the desired pattern on the corner cube surface of the microprismatic film 55, which is then laminated to aluminum sheets 56 at a pressure of about 15-20 psi, using pressure rolls 57. The printing and lamination speed will be about 10 feet a minute. The microprismatic film will be laminated continuously to aluminum sheets 56 that are typically four feet wide by eight feet long.

[0045] According to the ASTM D4956 – 13 Standard Specification for Retroreflective Sheeting for Traffic Control, the typical aluminum sign blanks are made of .080 inch (2.03 mm) thick 6061-T6 aluminum. More recently it is believed that other metals have been used as the substrate. In an embodiment, the metal substrate may range from 0.05 to 0.75 inches in thickness, such as, for example, 0.07 to 0.5 in, or 0.075 to 0.01 in. For purposes hereof, the word “metal” as used in the claims is intended to cover aluminum (as the approved version) and any other approved metal substrate that meets ASTM D4956 specifications.

[0046] The combined retroreflective film and aluminum panels can be separated by cutting the retroreflective film between individual panels 58, so the panels can be stacked (as shown at reference 59) and allowed to finish curing.

WHAT IS CLAIMED IS:

1. A retroreflective traffic sign consisting of:
a polymeric film having a front face and a rear face;
said rear face having a pattern of microprismatic retroreflective elements integrally formed as part of said film, a pattern of cell walls formed of an adhesive-containing polymer defining cells in which the microprismatic retroreflective elements are in the cells, and a substrate is adhered directly to the cell walls formed of the adhesive-containing polymer while leaving an air gap between the microprismatic retroreflective elements and the substrate in the cells.
2. The retroreflective traffic sign of claim 1, wherein the adhesive-containing polymer has a viscosity of 250,000 cP to 100,000,000 cP.
3. The retroreflective traffic sign of claim 1, wherein the substrate is selected from aluminum, powder coated steel, galvanized steel, PEEK, polycarbonate, PMMA, recycled tire rubber composites, carbon fiber, fiberglass, and wood composites treated for outdoor use.
4. The retroreflective traffic sign of claim 1, wherein the microprismatic retroreflective elements are corner cube prisms.
5. The retroreflective traffic sign of claim 1, wherein the traffic sign meets the

requirements of the ASTM D4956 – 13 standard.

6. The retroreflective traffic sign of claim 1, wherein the rear face having a pattern of microprismatic retroreflective elements, the cell walls, and the substrate define an air gap.

7. The retroreflective traffic sign of claim 1, wherein the polymeric film is a thermoplastic.

8. The retroreflective traffic sign of claim 1, wherein the thickness of the cell walls extending from the polymeric film to the substrate is 0.254 mm to 0.508 mm.

9. The retroreflective traffic sign of claim 1, wherein the polymeric film is 0.127 mm to 0.254 mm in thickness.

10. A method for forming a retroreflective traffic sign, comprising:
passing a film having retroreflective elements on one side thereof past a station;
at the station, applying a viscous polymer containing an adhesive in a pattern defining cell walls around areas of the retroreflective elements;
applying a side of the film having the cell walls directly to a substrate;
laminating the film to the substrate via the cell walls;
wherein the side of the film having the cell walls, the cell walls, and the substrate define an air gap; and

allowing the viscous material to cure while the film is adhered to said substrate.

11. The method of claim 10, wherein the microprismatic retroreflective elements are integrally formed as part of said film.

12. The method of claim 10, wherein the substrate is selected from aluminum, powder coated steel, galvanized steel, PEEK, polycarbonate, PMMA, recycled tire rubber composites, carbon fiber, fiberglass, and wood composites treated for outdoor use.

13. The method of claim 10, wherein the retroreflective elements are corner cube prisms.

14. The method of claim 10, wherein the traffic sign includes only the film and substrate layers laminated via the viscous polymer containing the adhesive.

15. The method of claim 10, further comprising applying lettering or symbols for the traffic sign to the side comprising the retroreflective elements.

15. The method of claim 10, wherein the thickness of the cell walls extending from the film to the substrate is 0.254 mm to 0.508 mm.

16. The method of claim 10, wherein the polymeric film is 0.127 mm to 0.254 mm

in thickness.

17. An apparatus for producing a retroreflective traffic sign, comprising:

means for feeding a thin film having retroreflective elements on one side of the film past a rotary screen having a pattern defining closed areas and open areas that will allow passage of a viscous adhesive-containing polymer through the open areas of the screen onto the side of the film having the retroreflective elements thereon to provide walls defining cells surrounding predetermined areas of the retroreflective elements;

means for feeding the film with the viscous polymer cell walls onto a substrate;

and

means for laminating the film to the substrate via said viscous polymer.

wherein the traffic sign optionally includes drive related directions on the front face of the film.

1/4

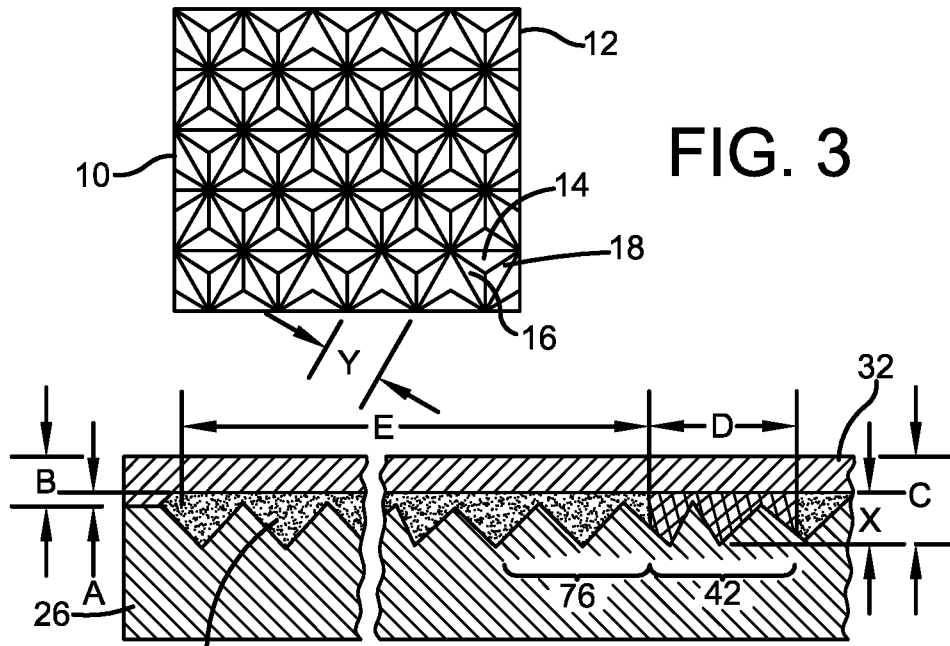

FIG. 3

FIG. 2

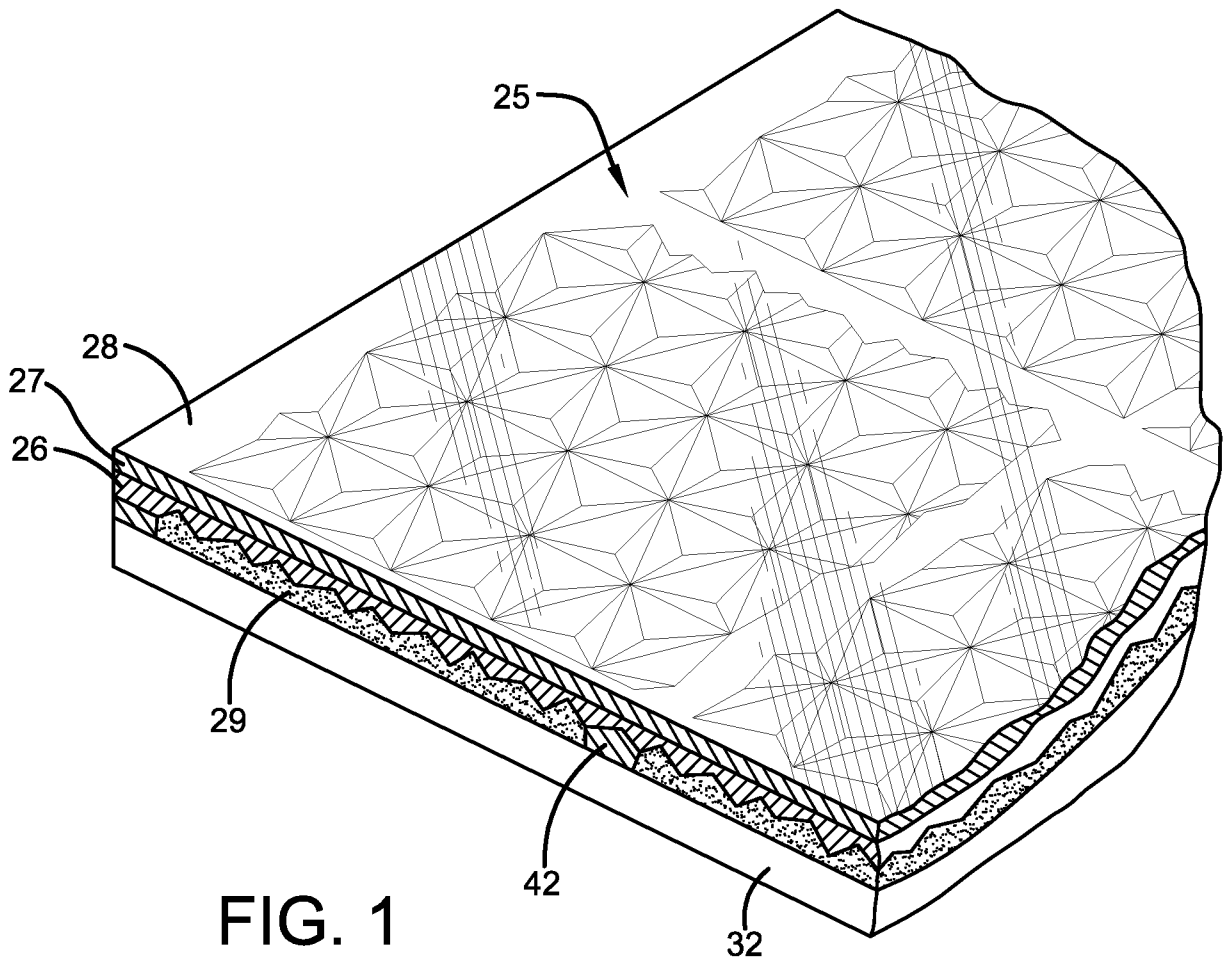

FIG. 1

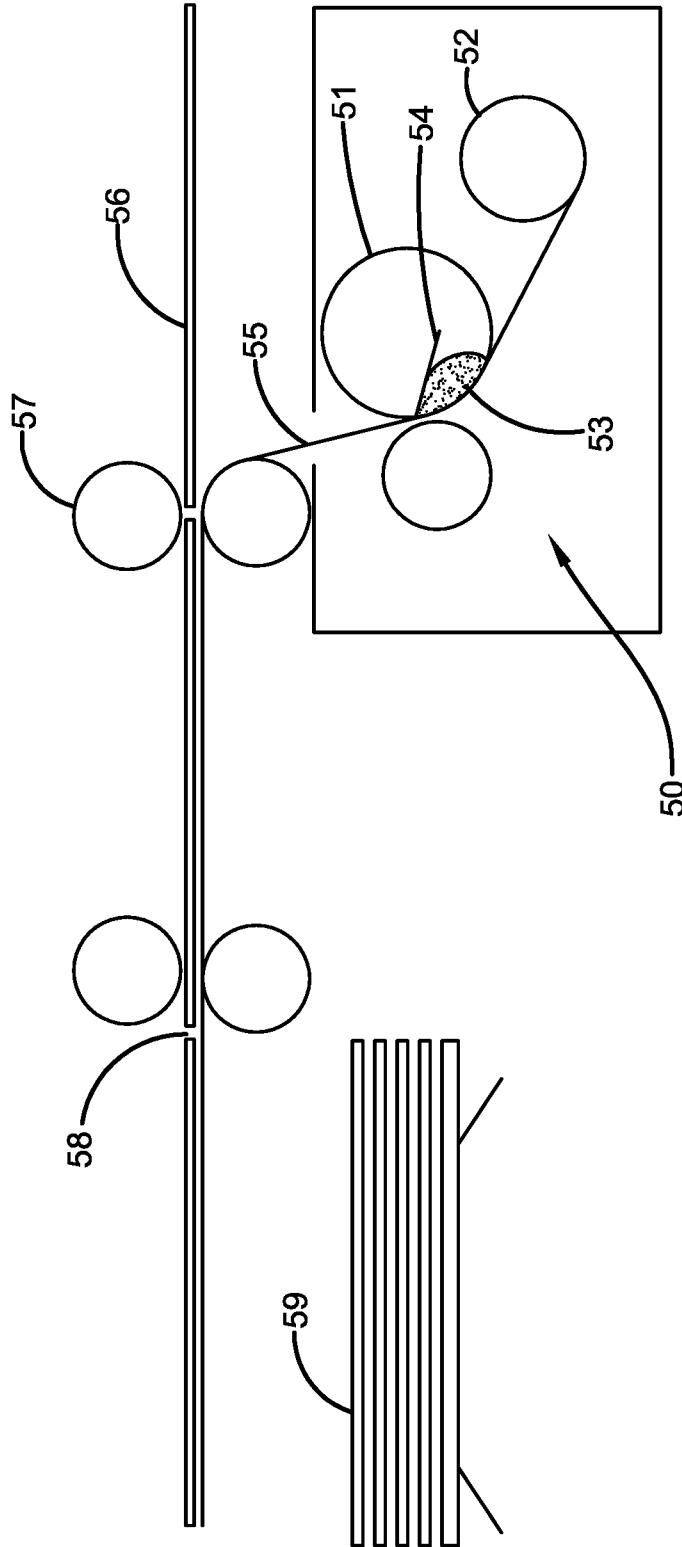

FIG. 4

3/4

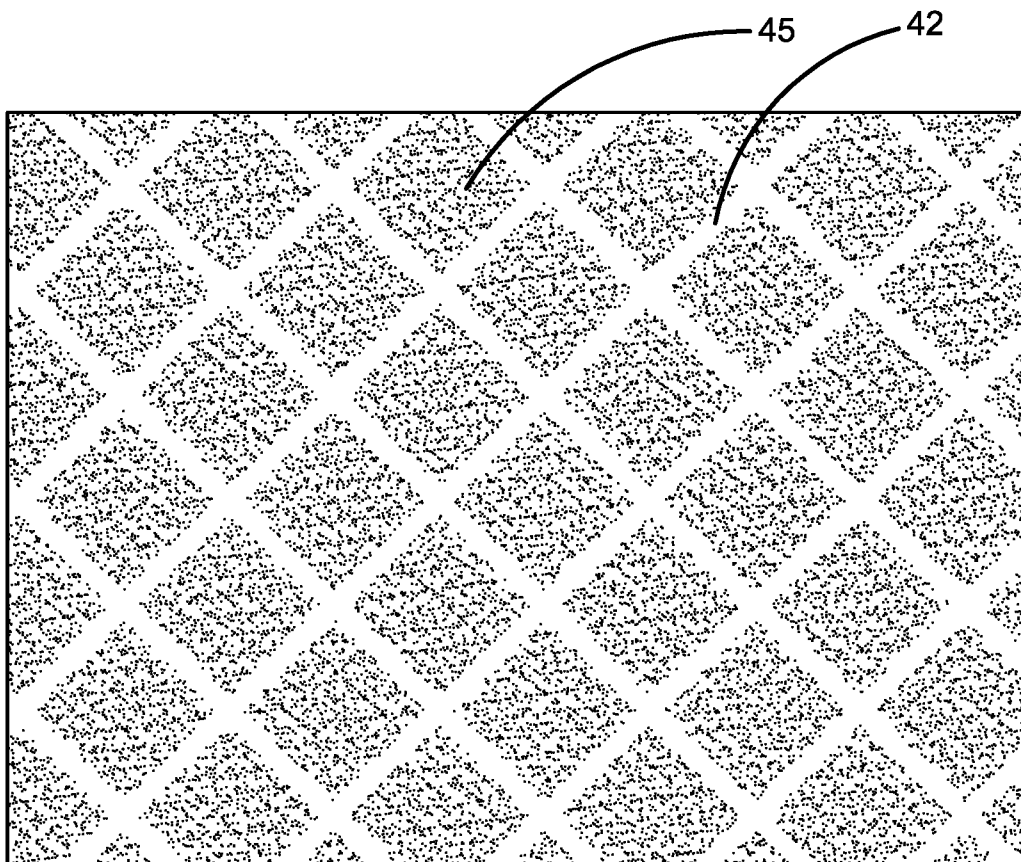

FIG. 5

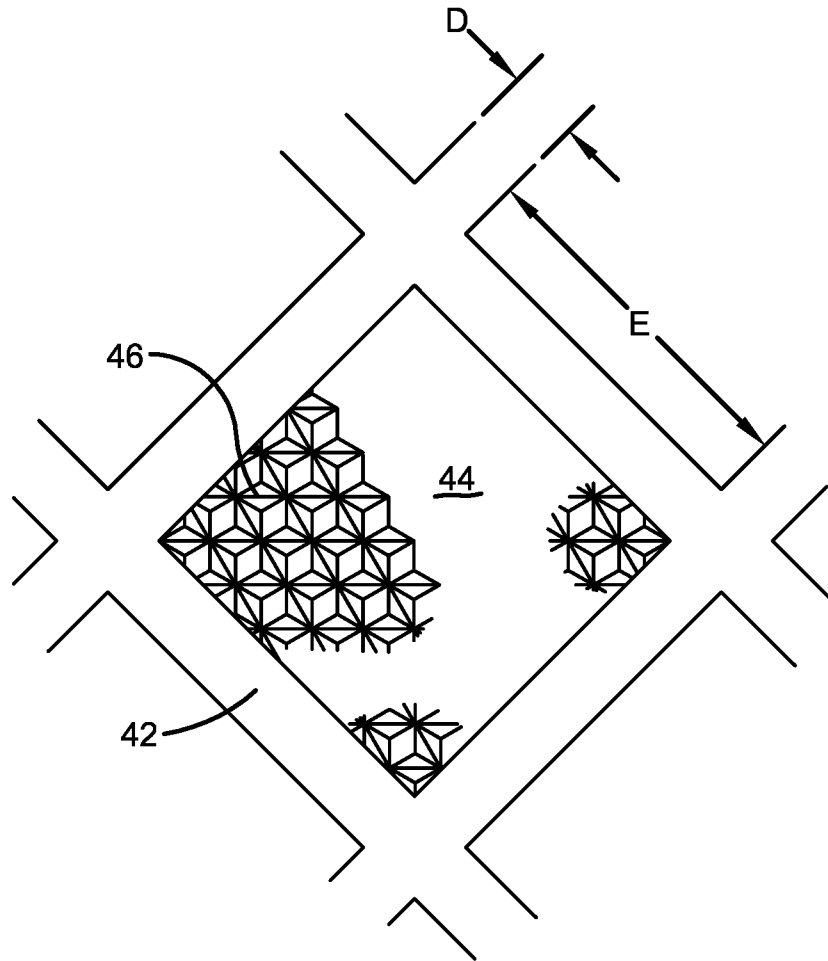

FIG. 6

