

L. CAUL.
 CARBONATING MACHINE.
 APPLICATION FILED DEC. 15, 1909.

974,774.

Patented Nov. 8, 1910.

2 SHEETS—SHEET 1.

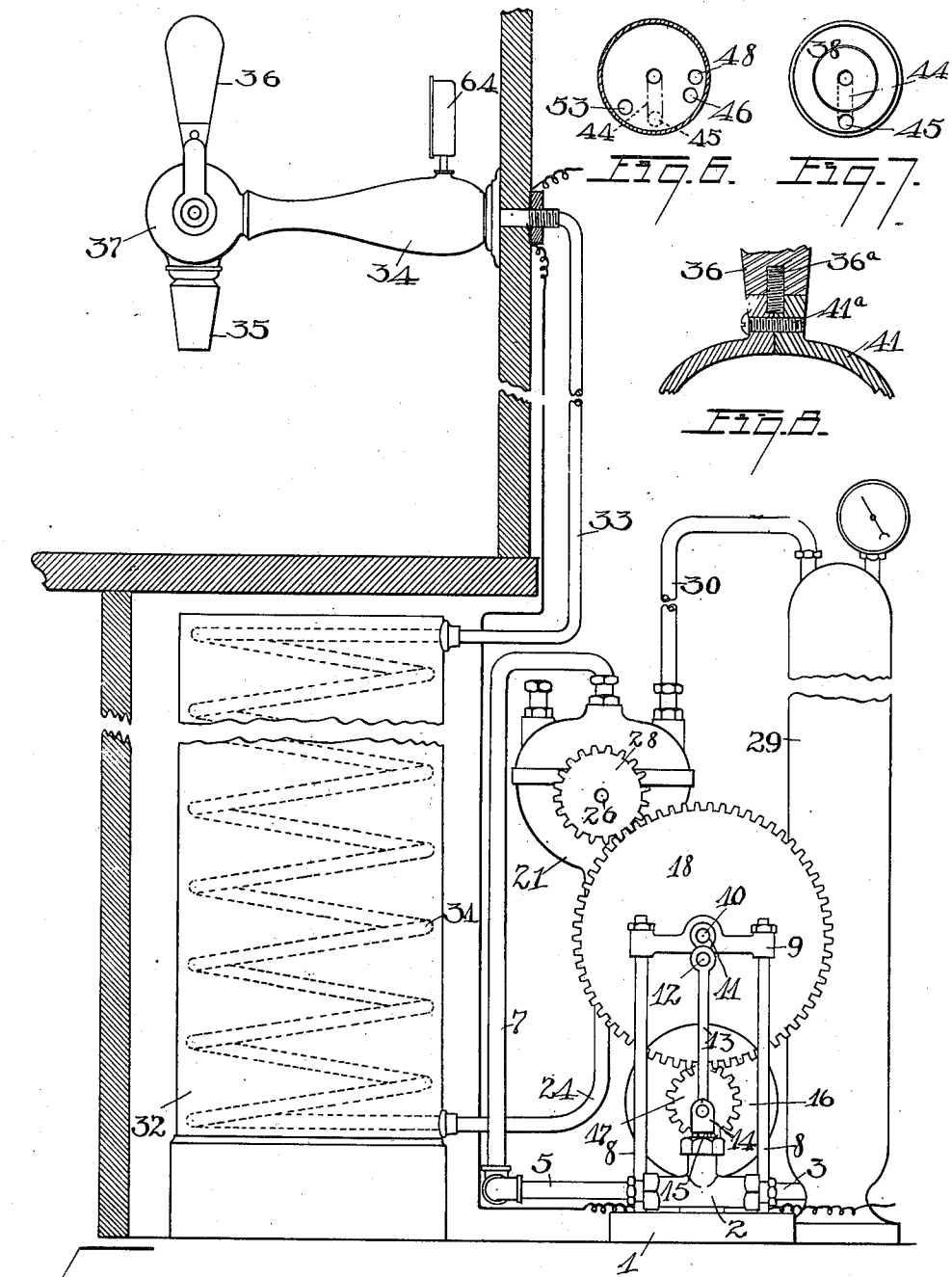

Witnesses
 Foreman & West.
 M. E. Paif.

FIG. 1.

Inventor
 Louis Caul,
 By Bates, Fouts & Hill,
 Attys.

L. CAUL.
 CARBONATING MACHINE.
 APPLICATION FILED DEC. 15, 1909.

974,774.

Patented Nov. 8, 1910.

2 SHEETS—SHEET 2.

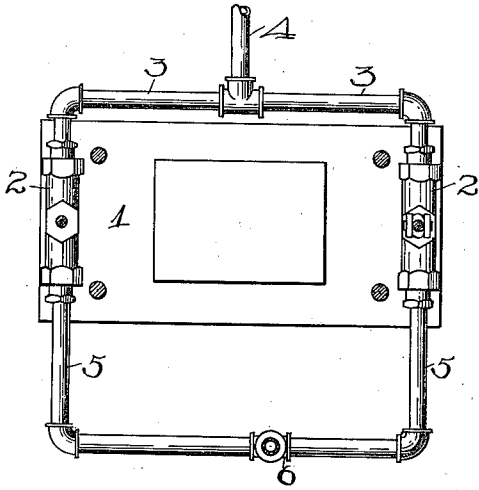

FIG. 3.

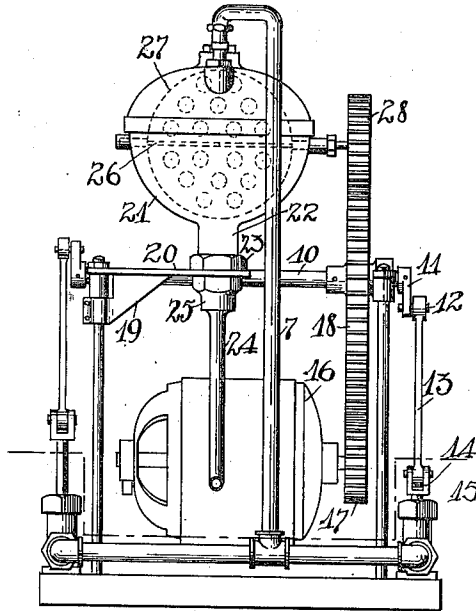

FIG. 2.

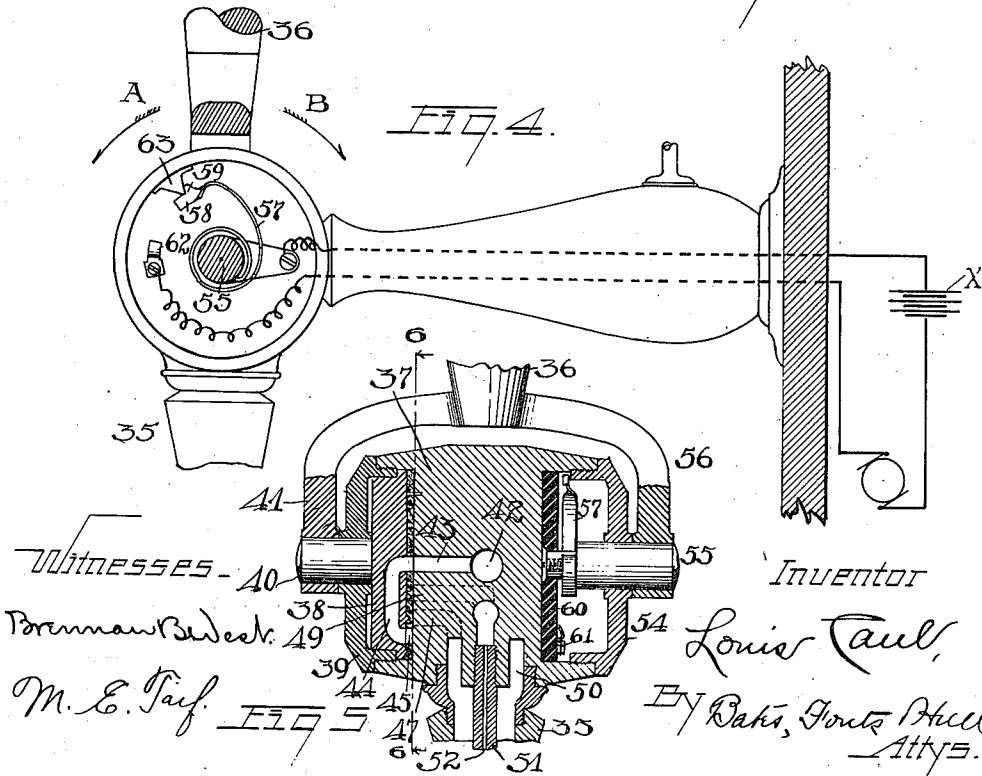

FIG. 4.

Witnesses -
 Bornman Beck.
 M. E. Paul.

Inventor
 Louis Caul,
 By Dakis, Forts Hill
 Atty's.

UNITED STATES PATENT OFFICE.

LOUIS CAUL, OF CLEVELAND, OHIO.

CARBONATING-MACHINE.

974,774.

Specification of Letters Patent.

Patented Nov. 8, 1910.

Application filed December 15, 1909. Serial No. 533,247.

To all whom it may concern:

Be it known that I, LOUIS CAUL, a citizen of the United States, residing at Cleveland, in the county of Cuyahoga and State of Ohio, have invented a certain new and useful Improvement in Carbonating-Machines, of which the following is a full, clear, and exact description, reference being had to the accompanying drawings.

My invention relates to machines for carbonating water and, more particularly, relates to the class of carbonating machines in which the gas and water are mixed and then delivered to the spigot or faucet which is controlled by the person drawing the carbonated water.

The object of the invention is to provide a simple compact machine which will perform its functions with certainty, be housed within a comparatively small amount of space, and further, to provide a machine in which the handle of the faucet or spigot will, by means of intermediate connections, cause the operation of the motor which pumps the water to the mixing chamber, the pressure of which water forces the mixed gas and water from the mixing chamber to the spigot.

Generally speaking, the invention comprises the elements and combinations thereof set forth in the accompanying claims.

Reference should be had to the accompanying drawings forming a part of this specification, in which—

Figure 1 shows the carbonating machine and cooling device for the carbonated water, in elevation, the casing which surrounds the machine being shown in section; Fig. 2 is a front elevation of the carbonating machine; Fig. 3 is a top plan view of the base, the pumps and connecting pipes, with the motor and mixing chamber removed; Fig. 4 is a side elevation of the spigot with the end cap and a portion of the operating handle removed, showing the electrical switch; Fig. 5 is a central vertical section through the head of the spigot and the associated parts; Fig. 6 is a section taken upon the line 6—6 of Fig. 5; Fig. 7 is a face view of the valve member which coöperates with the head of the spigot, and Fig. 8 is a central section of a portion of the spigot operating handle and a portion of the yoke.

In Fig. 1 is represented an arrangement of carbonating machine, cooling device for the carbonated water, spigot for delivering

the carbonated water and a casing which incloses the carbonating machine and cooler, and at the same time forms a counter below upon which the vessel to receive the carbonated water may be placed.

Upon the base 1 (see Fig. 3) is mounted two pumps 2 which are exactly similar in their construction. At one end these pumps communicate with pipes 3, which are joined to a single pipe 4, which pipe is in communication with a source of water. At the opposite ends, the pumps communicate with pipes 5, which are connected to the union 6 which is in turn connected to a vertical pipe 7. Upon the base 1 are mounted two pairs of uprights 8 which are joined at their upper ends by yokes 9. Bearing journal boxes are supported upon the opposite yokes and a shaft 10 is supported within the journal boxes. At the opposite ends of the shaft 10 are crank arms 11 which carry crank pins 12. Associated with the crank pins are links 13 which are pivoted upon a yoke member 14 carried by the pump piston 15, which operates within the cylinder of the pump. The crank arms 11 are arranged at an angle of 180 degrees with respect to each other upon the shaft 10, so that the pumps 2 work alternately in supplying water to the mixing chamber.

Upon the base 1 is mounted a motor 16 which, in the present instance, is an electrical motor of standard type. The motor carries upon its shaft a gear 17 which meshes with a gear 18, which is secured upon the shaft 10.

Upon one of the uprights 8, the bracket 19 is supported, which bracket is provided with an extending arm 20 upon which the mixing chamber 21 is mounted. The mixing chamber is somewhat cylindrical in shape at the lower portion and more or less elliptical in shape at the upper portion. The casing is formed in two parts, respectively secured together. The lower part of the casing is formed with an outlet link 22 which has a nut or boss 23 upon the lower part thereof. This nut or boss 23 rests upon the upper part of the extending arm 20 of the bracket. Below the bracket a pipe 24 extends, which is joined to the lower part of the mixing receptacle by means of a union 25. The union 25 and the nut 23 unite to clamp the mixing receptacle upon the arm 20 of the bracket.

The pipe 7, which, as will be remembered,

is the pipe that conducts the water that has passed through the pumps, is connected to the upper part of the mixing receptacle by means of a suitable connection and delivers the pumped water to the interior of the mixing receptacle. Within the receptacle is journaled a shaft 26, indicated in dotted lines in Fig. 2. Upon the shaft is mounted a suitable agitating device 27. The shaft 26 extends beyond the walls of the receptacle, and to its outer end is secured a gear 28, which is in mesh with the gear 18, previously mentioned.

From the above description it will be obvious that as the motor is set in motion, it will actuate the gear 17, which through the gear 18 will rotate the shaft 10 and through the connection of the gears 18 and 28 will rotate the agitators within the mixing receptacle.

Situated conveniently to the base is a gas tank 29, which tank is adapted to hold carbon di-oxid under pressure. This tank is connected with the mixing receptacle by means of the pipe 30 so that gas under pressure is supplied to the interior of the mixing receptacle. As before stated, the carbonated water is conducted away from the mixing receptacle 21 through the pipe 24, which connects with a coiled pipe 31, housed within a suitable receptacle 32. This receptacle may be packed with ice or cooling mixture so that the carbonated water passing through the coil 31 will be cooled in its passage.

The upper end of the coil 31 connects with a pipe 33, which extends through the spigot 34, and is delivered through the nozzle 35 upon the operation of the handle 36. The spigot 34 is formed with a head 37, which has recessed portions on both sides, in one of which portions is fitted a valve member 38. This valve member is held in position by means of a cap 39 which is fitted to close the recessed end in the head and interposed between said valve member and the surface with which it coöperates is a washer of suitable packing material. The valve member 38 is secured upon a stub shaft 40, which in turn is connected upon one arm of a yoke 41. For convenience in assembling the spigot, the yoke 41 is made in two parts secured together at their inner ends by a screw 41^a, as shown in Fig. 8. A stud 36^a is firmly clamped between the parts of the yoke for the purpose of supporting the operating handle 36.

Extending through the central portion of the spigot body is a passageway 42 which connects with the pipe 33 bearing carbonated water. This passage 42 connects with a side passageway 43 which is formed in the head of the spigot, and forms the center of the circle within which the valve member 38 rotates. A curved passage 44 in the valve member 38 extends from the center

thereof to near its outer edge. Consequently the passageways 43 and 44 are in constant communication, regardless of the rotary movement which may be imparted to the valve member through the operation of the handle 36. The outer end of the passage is formed with an opening 45 which is adapted to communicate with other openings in the spigot head.

By reference to Fig. 7 the construction of the passage 44 and the opening 45 will be understood, and in Fig. 6 is shown the various ports with which the port 45 is adapted to communicate. The port 46, shown in Fig. 6, communicates with a passage 47, shown in dotted lines in Fig. 5, while the port 48 communicates with a passage 49, also shown in Fig. 5, so that as the handle 36 is turned and by this means the valve member 38 is also turned, the port 45 may be made to coincide with either of the ports 46 or 48 and supply carbonated water to either of the passages 47 or 49.

The passage 47 communicates with the recessed portion 50 which is formed in the lower part of the spigot head and will flow out through the nozzle 35 giving a thick heavy stream of carbonated water, while the passage 49 communicates with an extended mouth-piece 51, which mouth-piece extends substantially to the lower portion of the part 35. Through the central part of the extension 51 is a small opening 52 which, as is well known in the art, will supply a thin forceful stream of carbonated water.

The port 45 is brought into register with the ports 46 and 48 by movement of the handle forward or toward the operator. However, the handle 36 may be operated to the rear of the vertical position or away from the operator when the port 45 will be brought into communication with a port 53, which by means of a suitable passage, similar in all respects to the passage 47, will permit the carbonated water to flow through the recessed portion 50 and through the nipple 35. The purpose of this construction will be later explained.

Upon the side of the spigot head, opposite to that already described, is a recess similar to the one previously described. This recess is likewise closed by means of a cap 54 through which extends a stub shaft 55 to which is secured one of the members of the yoke 41, joined to the handle 36. Within the cap and upon the shaft 55 is secured a coiled spring 57 which, as shown in Fig. 4, has at the end thereof a head-piece 58. This head-piece is formed with a projecting finger 59 and the end of the head is slightly bent so as to form a projecting curved portion.

In the head of the recess is secured a disk 60, which is of insulating material. Upon this disk is secured an electrode 61 which, as

shown in Fig. 4, forms a projecting portion 62, which has the outer end thereof bent to form a curved extension which is adapted to cooperate with the curved extension upon the head 58.

Upon the interior of the head and above the electrode 62 is secured a stop member 63. The stop member 63 will engage the finger 59 when the handle 36 is in substantially upright position. When the handle 36 is drawn in the direction of the arrow A, the shaft 55 will be turned in a counter-clockwise direction which will cause the spring 57 to be flexed and when the tension becomes sufficient the finger 59 will be dislodged from its engagement with the stop 63 and the head 58 will be projected into engagement with the parts 62 upon the electrode 61. The projecting portion 62 is provided with a slight, transverse depression, and the end of the head 58 is turned downward to engage said depression when the two parts are in connection. Therefore, when the stub shaft 55 is rotated in a direction to break the connection between the spring 57 and the electrode 61, the depression 62 will prevent the withdrawal of the down-turned portion of 58 until the spring has been placed under sufficient tension to not only disengage the parts, but to swing the projection 59 beyond the stop 63. Therefore, the disengagement will be instantaneous and the distance of separation between the parts great enough to prevent arcing.

The electrode 62 is connected by means of a suitable insulated connection with one of the binding posts upon the motor. Another electrical conductor is connected with the other binding post for the motor and is electrically connected with the spring 57 secured to the stub shaft 55 but insulated therefrom in any suitable manner. In this conductor is interposed a battery X, indicated in Fig. 4. The conductors pass through holes bored in the spigot, as indicated in dotted lines in Fig. 4.

It will be apparent from the foregoing description that when the handle 36 is pulled forwardly in the direction of arrow A, the members 58 and 62 will engage which will complete the electrical circuit through the battery X and supply an electric current to the motor, which in turn will pump water through the mixing receptacle where it will be impregnated with gas, and further, will force the carbonated water through the cooling coils 31, pipe 33 and through the passageway 42 in the spigot. If the handle 36 be drawn forwardly such a distance that the port 45 is in connection with the port 46 then the carbonated water will pass through the passageway 47 and will be delivered through the nipple 35 in a thick slow stream. Should the handle 36 be pulled forward far enough so that the port 45 registers with the

port 48, then the carbonated water will be delivered through the passageway 49, through the member 51 and issue from the nipple 35 in a thin stream with great velocity.

It may happen that when it is desired to draw carbonated water from the carbonating machine that the pressure within the mixing receptacle is already as great as the machine is designed to stand, so that if the spigot were merely opened, the carbonated water would issue with sufficient force without the employment of the pump. To accommodate such a contingency, the arrangement heretofore described of bringing into register the port 45 and the port 53 by the movement of the handle 36 in the direction indicated by arrow B, has been provided. As before described, when the parts are brought into such relation, the carbonated water may issue through the nozzle 35 and as the handle is being moved in the direction opposite to that necessary to make electrical connection, the projection 59 on the head 58 of the switch-spring will leave the stop 63 and swing idly to the rear. For the purpose of ascertaining the pressure of the carbonated water within the coil 31 and the mixing receptacle 21, a pressure gage 64 is provided and is mounted upon the body of the spigot 34 in convenient position for the user of the device to observe the recorded pressure.

From this description it will be seen that, if desired, water may be drawn from the spigot without the operation of the pumps; or water may be pumped into the system to a certain pressure, indicating on the pressure gage, without drawing it from the spigot by turning the operating handle in the direction of the arrow A a distance sufficient to operate the switch, but not sufficient to bring it to register the ports 45 and 46. Or water may be drawn at the same time it is being pumped by simply advancing the handle farther in the same direction until the port 45 is brought into communication with either of the ports 46 or 47, and the members 58 and 62 of the switch will remain in contact while the spring 57 yields to accommodate the excess movement of the stub shaft 55.

It will be apparent that various changes may be made in the arrangement of parts of the carbonating machine, as shown, without departing from the spirit of the invention, and I do not limit myself further than that which is specifically recited in the claims.

Having thus described my invention, what I claim is:

1. In a device of the character described, a mixing receptacle, an agitator within said receptacle, means for operating said agitator, a source of gas under pressure connected with the said receptacle, mechanism for forcing the water into the said receptacle, means for operating said mechanism,

in combination with a faucet, means connecting the said faucet with the mixing receptacle for conducting the fluid from the mixing receptacle, a handle upon said faucet and operative connections between the said faucet handle and the means for operating the water forcing mechanism and the agitator, whereby, when the handle is moved to permit the discharge of the fluid through the faucet, the said means for operating the water forcing mechanism and the agitating device will be put in operation.

2. In a device of the character described, a mixing receptacle, an agitating device within said mixing receptacle, a pump for forcing water into the interior of said receptacle, a motor for operating the said pump and the said agitating device, a source of gas under pressure connected with the interior of the mixing receptacle in combination with a faucet having a handle, connections between said faucet and the mixing receptacle to conduct the carbonated water, electrical connections between the faucet handle and the motor, whereby the motor will be actuated when the handle is moved to discharge the carbonated water.

3. In a device of the character described, a mixing receptacle, an agitating device within said mixing receptacle, a source of gas under pressure connected with the interior of the mixing receptacle, a pump for forcing water into the interior of the receptacle, a motor operatively connected to said pump and to the agitating device, in combination with a faucet having a handle, connections between said faucet and the mixing receptacle for conducting the contents of the mixing receptacle to the faucet, one element of an electric switch carried by the faucet handle, the second element of an electric switch mounted upon the body of the faucet, conductor wires connected with the elements of the electric switch and with the motor, whereby, when the handle is moved to open the faucet, the said switch members will be brought into contact, whereby the electric motor will be actuated and cause the operation of the pump and the agitating device.

4. In a device of the character described, a mixing receptacle, an agitating device within said mixing receptacle, a source of gas under pressure connected with the interior of the receptacle, a pump, a pipe connecting the pump with the mixing receptacle, a motor, operative connections between the motor and the pump and the agitating device, in combination with a faucet having a handle, a conducting pipe connected with the agitating device and the faucet, said faucet being provided with a handle, a valve member connected to said handle, ducts in the valve member and in the body of the faucet adapted to be brought

into register when the handle is moved in one direction to permit the discharge of the material from the mixing chamber, one element of an electric switch carried by the handle of said faucet, another element of an electrical switch carried by the body of the faucet, said switch members being brought into contact when the handle is moved to permit the discharge from the faucet in the manner described, electrical conductors connected with both switch members and with the motor, whereby the motor will be actuated when the handle is moved as described.

5. In a device of the character described, a mixing receptacle, an agitating device within said mixing receptacle, a source of gas under pressure connected with the interior of the receptacle, a pump, a pipe connecting the pump with the mixing receptacle, a motor, operative connections between the motor and the pump and the agitating device, in combination with a faucet, a conducting pipe connected with the mixing receptacle and the faucet, said faucet being provided with a handle, a valve member connected to said handle, ducts in the valve member and in the body of the faucet adapted to be brought into register when the handle is moved in one direction to permit the discharge of the material from the mixing chamber, one element of an electric switch carried by the handle of said faucet, another element of an electrical switch carried by the body of the faucet, said switch members being brought into contact when the handle is moved to permit the discharge from the faucet in the manner described, electrical conductors connected with both switch members and with the motor, whereby the motor will be actuated when the handle is moved as described, other ducts in the faucet body besides those previously mentioned, said ducts being connected with the ducts in the valve member to permit the discharge from the faucet when the handle is moved in the opposite direction to that previously described, the switch contact members being moved away from each other during the last mentioned operation of the handle.

6. In a device of the character described, a mixing receptacle, an agitating device within said mixing receptacle, a source of gas under pressure connected with the interior of the receptacle, a pump, a connection between the pump and the mixing receptacle, a motor, operative connections between the motor and the pump, in combination with a faucet, a conducting pipe connected with the mixing receptacle and the faucet, said faucet being provided with a handle, a valve member connected to said handle, ducts in the valve member and in the body of the faucet adapted to be brought into register when the handle is moved to

5 permit the discharge of the material from the mixing chamber, one element of an electric switch carried by the handle of the faucet, another element of an electric switch carried by the body of the faucet, said switch members being brought into contact just ahead of the time when the ducts in the valve and the faucet body come into contact whereby the motor may be operated without discharge of material from the mixing chamber, the said electrical switch elements being still in contact when the ducts in the valve body and the faucet body come into contact whereby the motor will be operated to operate the pump while the material is being discharged from the mixing chamber, substantially as specified.

7. In a device of the character described, a holding receptacle, a pump for forcing the fluid into the interior of such receptacle, a motor for operating said pump, in combination with a faucet having a handle, the said faucet being connected with the holding receptacle, an electrical switch, one member of said electrical switch being operatively connected with the faucet handle, electrical connections between said switch and the motor whereby the motor will be actuated when the handle is moved in a direction to discharge the carbonated water.

8. In a device of the character described, a mixing receptacle, a source of gas under pressure with said receptacle, mechanism for forcing the water into the said receptacle, means for operating said mechanism, in combination with a faucet, means connecting the said faucet with the mixing receptacle for conducting the fluid therefrom, a valve in said faucet, operative connections between the said faucet valve and the means for operating the water forcing mechanism thereby when the handle is moved to permit the discharge of the fluid through the faucet, the said means for operating the water forcing mechanism will be put in operation.

9. In a device of the character described, a mixing receptacle, a pump, connections between said pump and the mixing receptacle, a source of water connected with the pump, a source of gas under pressure connected with the mixing receptacle, a motor for operating said pump and the agitating device within

the mixing receptacle, in combination with a faucet, a connecting conduit between said faucet and the mixing receptacle, said faucet being provided with an opening through the body portion thereof which connects with the conducting conduit just mentioned, an operating handle for said faucet, said handle comprising a yoke which is pivotally mounted upon the head of the faucet, one of said yoke members being operatively connected to a valve member, there being ducts in the body portion of the faucet and a duct in the valve member, whereby, when the valve member is moved, the ducts will be brought into proper position to discharge the faucet, the other of said yoke members carrying a flexible electrical contact member, a stop upon the body portion of the faucet which engages the flexible contact member when the yoke and handle are in position occupied by them when the faucet is closed, a second contact member mounted upon the faucet but insulated therefrom, said flexible contact member being adapted to be disengaged from its stock and to engage with the last mentioned contact member when the handle is moved to open the faucet, electrical conductor members connecting each of the contact members with the motor, whereby the motor will be set in operation when the contact members meet.

10. In a device of the character described, the combination of a receptacle, a pump for forcing fluid into the interior of such receptacle, a motor for operating said pump, a faucet connected with said receptacle, a handle for said faucet, an electrical switch one member of which is operatively connected with said handle and the other member of which is adapted to be engaged by the former member when the handle is moved from its normally closed position, and electrical connections between said switch and said motor.

In testimony whereof, I hereunto affix my signature in the presence of two witnesses.

LOUIS CAUL.

Witnesses:

M. E. TAIT,
O. M. KAPPLER.