

W. S. MINOR.  
RAILWAY ROAD BED.  
APPLICATION FILED NOV. 12, 1910.

997,078.

Patented July 4, 1911.

2 SHEETS—SHEET 1.

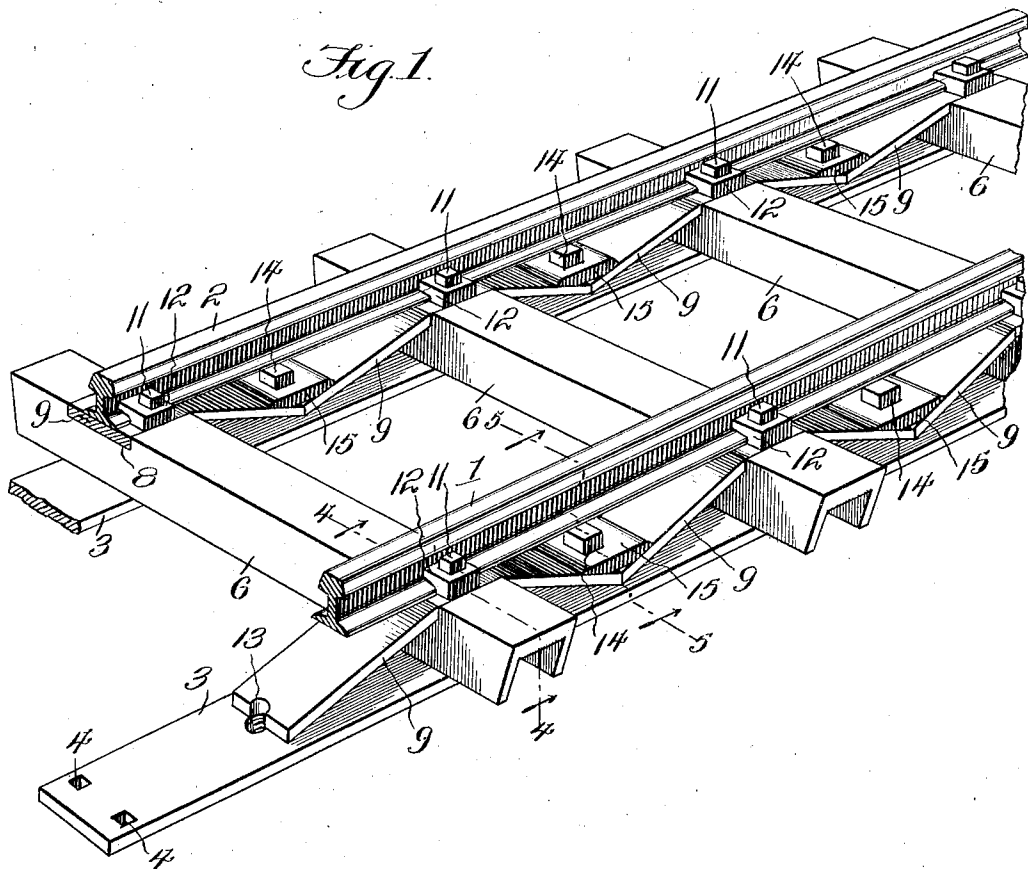
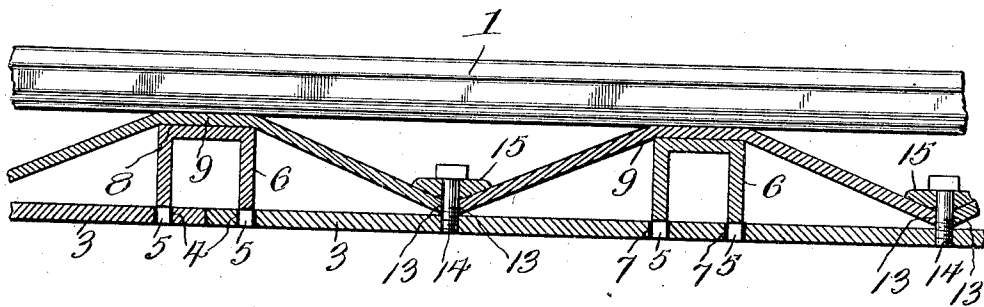

Fig. 2.



Witnesses

*J. L. Wright*  
*Edwards*

Inventor  
*William S. Minor*

By *Victor J. Evans*  
Attorney

W. S. MINOR.  
RAILWAY ROAD BED.  
APPLICATION FILED NOV. 12, 1910.

997,078.

Patented July 4, 1911.

2 SHEETS—SHEET 2.

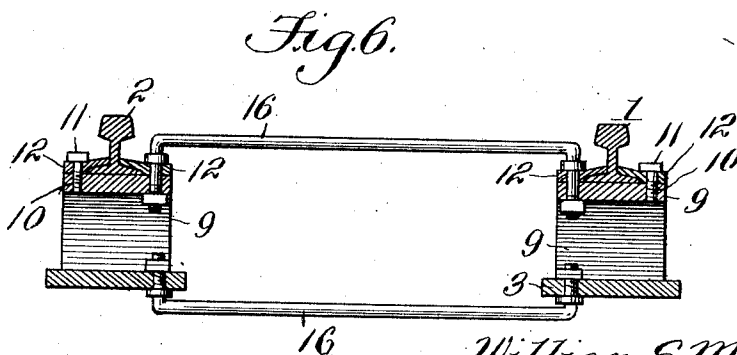
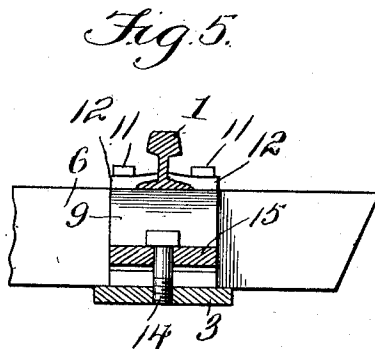
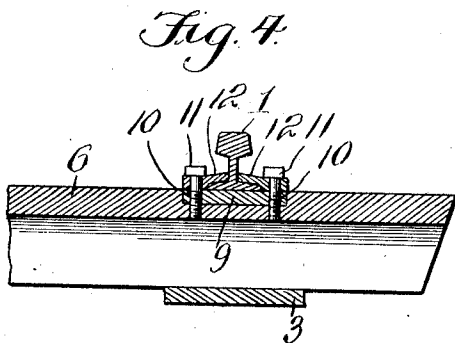
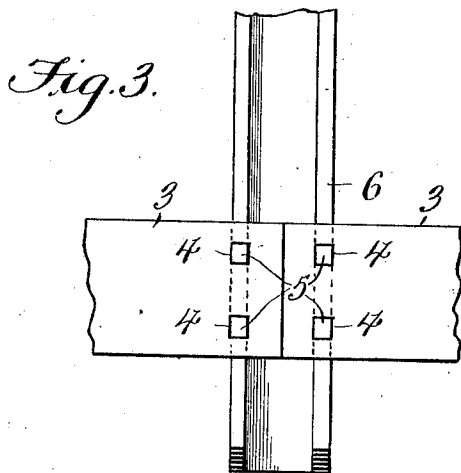

Witnesses  
*J. T. Wright*  
*Edw. von Staup*

Inventor  
*William S. Minor,*

By *Victor J. Evans,*  
Attorney

# UNITED STATES PATENT OFFICE.

WILLIAM S. MINOR, OF NORTHVILLE, NEW YORK.

## RAILWAY ROAD-BED.

997,078.

Specification of Letters Patent.

Patented July 4, 1911.

Application filed November 12, 1910. Serial No. 592,008.

*To all whom it may concern:*

Be it known that I, WILLIAM S. MINOR, a citizen of the United States, residing at Northville, in the county of Fulton and State of New York, have invented new and useful Improvements in Railway Road-Beds, of which the following is a specification.

This invention relates to railway roadbeds and more particularly to the construction of rail mountings.

The object of the invention is the provision of means for simply, cheaply and conveniently mounting the rails so as to dispense with the use of wooden ties and all their necessary paraphernalia.

A further object of the invention is the provision of means for dispensing with the use of wooden ties and for connecting and mounting the rails in such a manner that a more rigid and durable structure will be produced and which may be maintained at a considerably lower cost than roadbeds constructed with wooden ties.

A still further object of the invention is the provision of the use of metallic ties and stringers and inter-connecting braces between the ties and stringers which obviate or eliminate the use of approximately half of the ties which are used now.

Further objects of the invention will appear as the following specific description is read in connection with the accompanying drawings which form a part of this application, and in which:

Figure 1 is a perspective view of a section of track. Fig. 2 is a longitudinal sectional view of a portion of one of the rails and rail supports. Fig. 3 is a bottom plan view of the adjoining ends of a pair of stringers and a portion of tie which connects them. Fig. 4 is a transverse sectional view on the line 4-4 of Fig. 1. Fig. 5 is a similar view on the line 5-5 of Fig. 1. Fig. 6 is a sectional view showing a modification.

Referring more particularly to the drawing 1 and 2 represent the separate rails of the track and 3 represents the stringers which are placed in a roadbed in sections and run parallel with the rails. These stringers are preferably constructed of

suitable sheet metal and have apertures 4 formed on opposite sides thereof adjacent their ends so as to receive the depending lugs 5 arranged upon the lower side edges of the ties 6. The stringers are also provided with apertures 7 arranged at intervals throughout their length and in double pairs to receive the lugs 5 of the ties which are arranged intermediate the ends of the stringers. The ties which are adjacent the ends of the stringers have their lugs 5 connecting the two stringers together while the lugs 5 on the intermediate ties perform no function except to maintain the ties in position. All of the ties are constructed of substantially U-shape sheet steel or other suitable metal and have formed in their upper faces adjacent their ends the recesses 8 in which lie the upper portions of the braces 9. These braces are arranged over each tie and are supplied with apertures 10 in their upper faces to receive the attaching bolts 11 which are threaded into the ties and carry the washers or clips 12 which bear against the base of the rails and hold the same in position thereon. These bolts also prevent endwise movement of the braces upon the ties and assist the lugs 5 in keeping the ties in position.

The braces 9 extend from their connection with the ties diagonally downward in each direction so that the ends of the adjacent braces meet at a point intermediate the adjacent ties upon the stringer. Their ends are provided with suitable notches 13 which, when in register form a bolt receiving aperture adapted to permit the passage of clamping bolts 14 which carry washers 15 adapted to engage both of the braces and hold them in proper position upon the stringer. The braces are made in the form of cantalivers in that they extend from bolt to bolt over the ties and thereby remove most of the weight from the ties which may be conveniently dispensed with and simple connecting rods 16 are bridged between the braces 9 on opposite sides of the track, and between the separate stringers, as shown in Fig. 6. With the cantaliver braces pressure on the stringers is distributed over a greater area and thereby the wear upon the roadbed is materially lessened. The hereindescribed

construction may be embedded in any suitable roadbed, such as a cement or granolithic bed.

5 Having thus described the invention, what is claimed is —

10 In a roadbed construction, the combination with a pair of rails, of stringers arranged beneath the rails and separated therefrom, said stringers being arranged in sections, ties interconnecting the stringers and

rails, means carried by certain of said ties for joining the sections of the stringers, and braces interconnecting the stringers and rails and passing over the ties.

In testimony whereof I affix my signature 15 in presence of two witnesses.

WILLIAM S. MINOR.

Witnesses:

JOHN J. BANNAN,  
JAMES R. MONK.

---

Copies of this patent may be obtained for five cents each, by addressing the "Commissioner of Patents, Washington, D. C."

---