

(19) World Intellectual Property Organization
International Bureau



(43) International Publication Date
7 July 2005 (07.07.2005)

PCT

(10) International Publication Number
WO 2005/060882 A1

(51) International Patent Classification⁷: **A61F 5/00, 2/06**

(21) International Application Number:
PCT/US2004/017591

(22) International Filing Date: 1 June 2004 (01.06.2004)

(25) Filing Language: English

(26) Publication Language: English

(30) Priority Data:
60/528,084 9 December 2003 (09.12.2003) US
60/544,527 13 February 2004 (13.02.2004) US

(71) Applicant (for all designated States except US): **GI DYNAMICS, INC.** [US/US]; 150 California Street, Newton, MA 02458 (US).

(72) Inventors; and

(75) Inventors/Applicants (for US only): **MEADE, John, C.**

[US/US]; 85 Millville Road, Mendon, MA 01756 (US). **LEVINE, Andy, H.** [US/US]; 1105 Walnut Street, Newton, MA 02461 (US). **MELANSON, David, A.** [US/US]; 5 Schaefer Circle, Hudson, NH 03051 (US). **CVINAR, John, F.** [US/US]; 94 Ridge Street, Winchester, MA 01890 (US).

(74) Agents: **SMITH, James, M.** et al.; Hamilton, Brooks, Smith & Reynolds, P.C., 530 Virginia Road, P.O. Box 9133, Concord, MA 01742-9133 (US).

(81) Designated States (unless otherwise indicated, for every kind of national protection available): AE, AG, AL, AM, AT, AU, AZ, BA, BB, BG, BR, BW, BY, BZ, CA, CH, CN, CO, CR, CU, CZ, DE, DK, DM, DZ, EC, EE, EG, ES, FI, GB, GD, GE, GH, GM, HR, HU, ID, IL, IN, IS, JP, KE, KG, KP, KR, KZ, LC, LK, LR, LS, LT, LU, LV, MA, MD, MG, MK, MN, MW, MX, MZ, NA, NI, NO, NZ, OM, PG, PH, PL, PT, RO, RU, SC, SD, SE, SG, SK, SL, SY, TJ, TM, TN, TR, TT, TZ, UA, UG, US, UZ, VC, VN, YU, ZA, ZM, ZW.

[Continued on next page]

(54) Title: APPARATUS TO BE ANCHORED WITHIN THE GASTROINTESTINAL TRACT AND ANCHORING METHOD

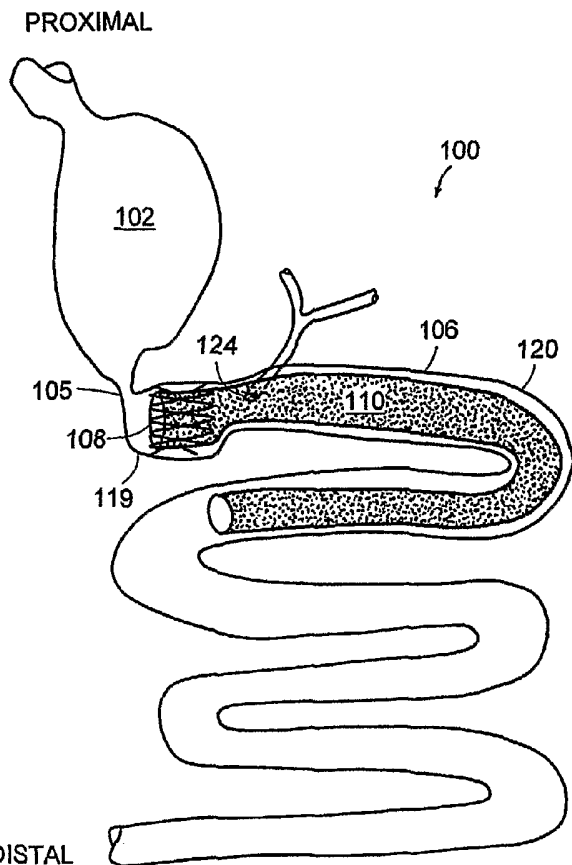

(57) Abstract: The present invention relates to an anchor (108) configured for minimally-invasive implantation and sized to remain securely positioned within at least a portion of the gastrointestinal tract (119) of an animal. The anchor includes a radial spring (100) formed from an elongated resilient member shaped into an annular wave pattern about a central axis (115). The anchor defines a central lumen and provides an outward radial force, while allowing for substantial flexure about its perimeter. The anchor is generally removable, but can include fasteners, such as barbs (640), to further secure it to the surrounding anatomy. In some embodiments, the anchor includes a connector (1405) coupling a fixed portion to a removable portion. Further, the anchor can be used to secure a medical device within the body, such as a flexible sleeve (110) within the intestine.

WO 2005/060882 A1



(84) **Designated States** (unless otherwise indicated, for every kind of regional protection available): ARIPO (BW, GH, GM, KE, LS, MW, MZ, NA, SD, SL, SZ, TZ, UG, ZM, ZW), Eurasian (AM, AZ, BY, KG, KZ, MD, RU, TJ, TM), European (AT, BE, BG, CH, CY, CZ, DE, DK, EE, ES, FI, FR, GB, GR, HU, IE, IT, LU, MC, NL, PL, PT, RO, SE, SI, SK, TR), OAPI (BF, BJ, CF, CG, CI, CM, GA, GN, GQ, GW, ML, MR, NE, SN, TD, TG).

For two-letter codes and other abbreviations, refer to the "Guidance Notes on Codes and Abbreviations" appearing at the beginning of each regular issue of the PCT Gazette.

Published:

— with international search report

APPARATUS TO BE ANCHORED WITHIN THE GASTROINTESTINAL TRACT AND ANCHORING METHOD

RELATED APPLICATIONS

This application claims the benefit of U.S. Provisional Application
5 No. 60/528,084, filed on December 9, 2003; and U.S. Provisional Application
No. 60/544,527, filed on February 13, 2004. The entire teachings of the above
applications are incorporated herein by reference.

BACKGROUND OF THE INVENTION

According to the Center for Disease Control (CDC), over sixty percent of the
10 United States population is overweight, and almost twenty percent are obese. This
translates into 38.8 million adults in the U.S. with a Body Mass Index (BMI) of 30
or above. The BMI is defined as a person's weight (in kilograms) divided by height
(in meters), squared. To be considered clinically, morbidly obese, one must meet at
least one of three criteria: (i) BMI over 35; (ii) 100 lbs. overweight; or (iii) 100%
15 above an "ideal" body weight. There is also a category for the super-obese for those
weighing over 350 lbs.

Obesity is an overwhelming health problem. Because of the enormous strain
associated with carrying this excess weight, organs are affected, as are the nervous
and circulatory systems. In 2000, the National Institute of Diabetes, Digestive and
20 Kidney Diseases (NIDDK) estimated that there were 280,000 deaths directly related
to obesity. The NIDDK further estimated that the direct cost of healthcare in the
U.S. associated with obesity is \$51 billion. In addition, Americans spend \$33 billion
per year on weight loss products. In spite of this economic cost and consumer
commitment, the prevalence of obesity continues to rise at alarming rates. From
25 1991 to 2000, obesity in the U.S. grew by 61%. Not exclusively a U.S. problem,
worldwide obesity ranges are also increasing dramatically.

One of the principle costs to the healthcare system stems from the co-
morbidity associated with obesity. Type-2 diabetes has climbed to 7.3% of the

population. Of those persons with Type-2 diabetes, almost half are clinically obese, and two thirds are approaching obese. Other co-morbidities include hypertension, coronary artery disease, hypercholesteremia, sleep apnea and pulmonary hypertension.

5 Although the physiology and psychology of obesity are complex, the medical consensus is that the cause is quite simple - an over intake of calories combined with a reduction in energy expenditures seen in modern society. While the treatment seems quite intuitive, the institution of a cure is a complex issue that has so far vexed the best efforts of medical science. Dieting is not an adequate long-
10 term solution for most people. Once an individual has slipped past the BMI of 30, significant changes in lifestyle are the only solution.

 There have been many attempts in the past to surgically modify patients' anatomies to attack the consumption problem by reducing the desire to eat. Stomach saplings, or gastroplasties, to reduce the volumetric size of the stomach, therein
15 achieving faster satiety, were performed in the 1980's and early 1990's. Although able to achieve early weight loss, sustained reduction was not obtained. The reasons are not all known, but are believed related to several factors. One of which is that the stomach stretches over time increasing volume while psychological drivers motivate patients to find creative approaches to literally eat around the smaller
20 pouch.

 There are currently two surgical procedures that successfully produce long-term weight loss; the Roux-en-Y gastric bypass and the biliopancreatic diversion with duodenal switch (BPD). Both procedures reduce the size of the stomach plus shorten the effective-length of intestine available for nutrient absorption. Reduction
25 of the stomach size reduces stomach capacity and the ability of the patient to take in food. Bypassing the duodenum makes it more difficult to digest fats, high sugar and carbohydrate rich foods. One objective of the surgery is to provide feedback to the patient by producing a dumping syndrome if they do eat these food products. Dumping occurs when carbohydrates directly enter the jejunum without being first
30 conditioned in the duodenum. The result is that a large quantity of fluid is discharged into the food from the intestinal lining. The total effect makes the patient

feel light-headed and results in severe diarrhea. For reasons that have not been determined the procedure also has an immediate therapeutic effect on diabetes.

Although the physiology seems simple, the exact mechanism of action in these procedures is not understood. Current theory is that negative feedback is provided from both regurgitation into the esophagus and dumping when large volumes of the wrong foods are eaten. Eventually, patients learn that to avoid both these issues they must be compliant with the dietary restrictions imposed by their modified anatomy. In the BPD procedure, large lengths of jejunum are bypassed resulting in malabsorption and therefore, reduced caloric uptake. In fact, the stomach is not reduced in size as much in the BPD procedure so that the patient is able to consume sufficient quantities of food to compensate for the reduced absorption. This procedure is reserved for the most morbidly obese as there are several serious side effects of prolonged malabsorption.

Unfortunately, these procedures carry a heavy toll. The morbidity rate for surgical procedures is alarmingly high with 11% requiring surgical intervention for correction. Early small bowel obstruction occurs at a rate of between 2-6% in these surgeries and mortality rates are reported to be approximately 0.5-1.5%. While surgery seems to be an effective answer, the current invasive procedures are not acceptable with these complication rates. Laparoscopic techniques applied to these surgeries provide fewer surgical complications but continue to expose these very ill patients to high operative risk in addition to requiring an enormous level of skill by the surgeon.

Devices to reduce absorption in the small intestines have been proposed (See U.S. Patent Number 5,820,584 (Crabb), U.S. Patent Number 5,306,300 (Berry) and U.S. Patent Number 4,315,509 (Smit)). However, these devices have not been successfully implemented.

SUMMARY OF THE INVENTION

One of the primary challenges in using medical devices to treat obesity is securing the device within the gastrointestinal tract. The natural lumens of the esophagus, stomach, and intestine provide relatively large diameters compared to the dimensions of delivery devices, such as endoscopes and/or catheters that are sized to

minimize trauma to the natural lumen. Further complicating matters are the natural muscular contractions of that portion of the anatomy that subject devices implanted therein to substantial stresses and strains. Additionally, other forces such as gas bubbles within the intestine can compound matters by further increasing a local
5 diameter of the intestine.

Thus, the combination of the large, varying diameters and muscular contractions tend to dislodge devices implanted therein. Additionally, the natural peristaltic contractions of the intestine attempt to push any device implanted therein either distally along with the normal passage of chyme, or proximally due to
10 retrograde contractions.

Non-surgical methods of implantation, such as endoluminal placement are attractive, but offer further challenges for inserting devices configured to attach to such large-diameter lumens. These devices have installed diameters of about 20-30 millimeters (mm) and are preferably inserted through substantially smaller
15 apertures. Minimally-invasive techniques for accessing the gastrointestinal tract include insertion through natural body lumens (e.g., per-oral, per-rectal). Further, to reduce trauma to the lumen, the access channel is preferably smaller in diameter than the lumen itself. Thus, access to the intestine may be limited by the interior diameter of a working catheter, or about 12 mm.

The present invention solves these problems by providing an anchor
20 configured for catheter-based implantation and sized to remain securely positioned within at least a portion of the gastrointestinal tract, including the intestine. The anchor includes a radial spring formed from an elongated resilient member shaped into an annular wave pattern about a central axis. Thus, the anchor provides an
25 outward radial force, but allows substantial flexure about its perimeter. Such flexure is important to allow catheter-based delivery and to provide compliance, thereby ensuring that the device will conform to the surrounding anatomical structure.

The annular wave element defines a lumen along its central axis formed between two open ends of the anchor. When implanted, the central axis of the
30 anchor is substantially aligned with the central axis of the gastrointestinal tract, allowing chyme to pass through the device. Additionally, the anchoring device minimizes trauma to the tissue by providing sufficient flexibility and compliance,

which minimizes the likelihood of tissue erosion and yet provides a solid anchoring and sealing point in the tissue.

The anchor can be removably attached within the body using mechanical fasteners such as barbs, surgical staples, and sutures and/or other fasteners, such as surgical adhesives. In an alternative embodiment, the anchor includes a portion that is fixedly attached within the body. A connector can also be provided and configured to attach a removable portion to the fixed portion. At least one application includes the treatment of obesity. Additional applications include the treatment of intestinal disorders. For these applications, the anchor enables a sleeve, or barrier, to be securely implanted within the intestine. When implanted, the sleeve acts to block the uptake of food in that portion of the intestine and/or the triggering of normal hormone response to food.

The invention relates to a gastrointestinal implant device including a wave anchor compressible in a radial direction. The wave anchor is formed by an elongated resilient member about a central axis and defines a central lumen. The resilient member defines an oscillating pattern between the first end and the second end of the device. The wave anchor is configured for insertion within a natural lumen of a gastrointestinal tract of an animal body. The central lumen can be the intestine, such as the esophagus, the stomach, the duodenum, the jejunum, the ileum and/or the colon.

In some embodiments, the oscillating pattern of the wave anchor has at least four oscillations. Generally, the resilient member is formed from a metal, an alloy, a plastic, or combinations of these materials. For example, the resilient member can include a shape-memory alloy, such as a Nickel-Titanium alloy commonly referred to as Nitinol.

In some embodiments, the elongated resilient member includes a plurality of strands. Moreover, some of the plurality of strands can have different physical properties. More generally, the elongated resilient member can include a first length having an associated physical property and a second length having a different associated physical property. For example, the physical property can be resiliency, thickness, and/or cross-sectional profile.

The central lumen of the wave anchor defines a diameter that is variable between a relaxed state and a compressed state. Also, an axial length separates the first end and second end of the anchor. Notably, the ratio of the implanted axial length to diameter ratio is at least about one (e.g., 30x30 mm, or 40x 40 mm). In a relaxed state (i.e., before implantation) the length-to-diameter ratio can be as low as 0.8. In some embodiments, the relaxed diameter is about 45 mm, which compresses to about 30 mm when implanted.

Further, the device can include a feature for securing the wave anchor within a natural lumen of the gastrointestinal tract. For example, the feature can include an interference fit formed between the wave anchor and the natural lumen. Alternatively, or in addition, the feature can include a mechanical fastener, a chemical fastener, or combinations thereof. Chemical fasteners include surgical adhesive; whereas, mechanical fasteners include barbs, sutures, staples, and combinations thereof.

In some embodiments, the implant device is secured within the natural lumen using a number of barbs. These barbs can be arranged around one of the ends of the device. Further, the implant device can also be secured using a number of barbs arranged around the same end, or the other end of the device. Generally, each barb includes an elongated member, attached at one end to the device with its other end extending away from the device being sized to engage muscular tissue of the natural lumen. In some embodiments, the barbs are bioerodible. Such bioerodible barbs are well suited for implantation as they serve to temporarily secure an anchor to the surrounding tissue. Then, after degrading, the anchor is free to detach, and for intestinal applications, natural peristalsis can assist in removing the anchor from the body without the need for a second surgical procedure.

The invention also relates to a method of treatment using an unsupported, flexible sleeve having a wave anchor coupled to its proximal end. The sleeve is configured for implantation into a natural lumen of a gastrointestinal tract of an animal body.

Further, the invention relates to a gastrointestinal implant device including a first annular element configured for insertion into a natural lumen of a gastrointestinal tract of an animal, a fastener for fixedly securing the first annular

element within the natural lumen, a gastrointestinal implant, and a connector for removably coupling between the first annular element and the gastrointestinal implant. The fastener can be a mechanical fastener, a chemical fastener, and combinations thereof. For example, the mechanical fastener can be one or more
5 barbs, sutures, staples, and combinations thereof.

Additionally the gastrointestinal implant can include a second annular element. The second annular element can include an elongated sleeve having a proximal end and a distal end and defining a central lumen therebetween. The connector can be a clasp attached to one of the first annular element and the
10 gastrointestinal implant and configured for engaging a feature of the other of the first annular element and the gastrointestinal implant. Alternatively, or in addition, the connector can be actuated by magnetic attraction. For example, the connector can include a magnet attached to one of the first annular element and the gastrointestinal implant and configured for engaging a feature of the other of the first annular
15 element and the gastrointestinal implant.

Still further, the invention relates to a process for implanting a gastrointestinal device. The process includes inserting a first annular element into a natural lumen of a gastrointestinal tract of an animal. The first annular element is then fixedly secured within the natural lumen. Next, a gastrointestinal implant is
20 provided and removably coupled to the first annular element. Notably, fixedly securing the first annular element can include providing a fastener, such as a mechanical fastener, a chemical fastener, or combinations thereof. For example, the mechanical fastener can be a barb, a suture, a staple, or combinations of any of these fasteners.

25 In some embodiments, the gastrointestinal implant includes a second annular element, such as an elongated sleeve having a proximal end and a distal end and defining a central lumen therebetween.

Removably coupling can include providing a clasp, attaching the clasp to one of the first annular element and the gastrointestinal implant, and engaging with the
30 clasp a feature of the other of the first annular element and the gastrointestinal implant. Alternatively, or in addition, removably coupling includes providing a connector actuated by magnetic attraction. The connector is coupled to one of the

first annular element and the gastrointestinal implant, and magnetically engages a connector a feature of the other of the first annular element and the gastrointestinal implant.

5 BRIEF DESCRIPTION OF THE DRAWINGS

The foregoing and other objects, features and advantages of the invention will be apparent from the following more particular description of preferred embodiments of the invention, as illustrated in the accompanying drawings in which like reference characters refer to the same parts throughout the different views. The drawings are not necessarily to scale, emphasis instead being placed upon
10 illustrating the principles of the invention.

FIGS. 1A and 1B are respectively schematic diagrams of an end-view and a side view of one embodiment of the invention in a relaxed state;

FIG. 1C is a schematic diagram of a side view of the embodiment of the
15 invention illustrated in FIGS. 1A-1B in a compressed state;

FIG. 2A is a schematic diagram of a perspective view of the invention illustrated in FIGS. 1A-1B;

FIG. 2B is a schematic diagram of a perspective view of an alternative embodiment of the invention;

FIGS. 3A through 3D are schematic diagrams of exemplary alternative
20 embodiments of a wave pattern;

FIG. 4 is a schematic diagram of a side view of an embodiment of the invention including an elongated sleeve;

FIGS. 5A-5C are schematic diagrams showing alternative types of
25 reinforcement of the embodiment of the invention shown in FIG. 4.

FIG. 6 is a schematic diagram of an embodiment of the invention illustrated in FIG. 4 implanted within a natural lumen of a gastrointestinal tract of an animal body;

FIG. 7 is a more-detailed cross-sectional diagram of one embodiment of the
30 invention inserted within a natural lumen;

FIG. 8A is a more detailed schematic diagram of an embodiment of the barbs illustrated in FIG. 7;

FIG. 8B is a more detailed schematic diagram of the tip of one of the barbs illustrated in FIG. 8A;

FIGS. 8C-8D are schematic diagrams of insertion of the embodiment of the invention illustrated in FIGS. 8A and 8B within a natural lumen;

5 FIG. 8E is a schematic diagram of an alternative embodiment of barbs;

FIG. 9 is a schematic diagram of a side view of an alternative embodiment of the invention including sleeve barbs;

FIGS. 10A-10B are more detailed schematic diagrams of one embodiment of sleeve barbs;

10 FIGS. 11A-11B are more detailed schematic diagrams of an alternative embodiment of sleeve barbs;

FIGS. 12A-12B are more detailed schematic diagrams of yet another alternative embodiment of sleeve barbs;

15 FIG. 13 is a graph of representative compliance curves for different embodiments of the invention;

FIGS. 14A-14B are schematic diagrams respectively of an embodiment of a connector engaged, and engaging;

FIG. 15A is a perspective view of one portion of a magnetically-coupled wave anchor device;

20 FIG. 15B is a perspective view of a mating portion of the magnetically-coupled wave anchor device of FIG. 15A;

FIG. 15C is a side view of both portions of the magnetically-coupled wave anchor device shown in an uncoupled configuration;

25 FIGS. 15D and 15E are respectively a side and end view of a magnetically-coupled wave anchor device shown in a coupled configuration;

FIG. 16 shows one embodiment of the invention including barbs that are integrally-formed; and

FIG. 17 shows an alternative embodiment of the invention including barbs that are integrally-formed.

30

DETAILED DESCRIPTION OF THE INVENTION

A description of preferred embodiments of the invention follows.

The present invention relates to an anchor configured for minimally-invasive implantation and sized to remain securely positioned within at least a portion of the gastrointestinal tract of an animal. The anchor includes a radial spring formed from an elongated resilient member shaped into an annular wave pattern about a central axis. Thus, the anchor provides an outward radial force, but allows substantial flexure about its perimeter. Such flexure is important to allow catheter-based delivery (e.g., endoluminal) and to provide compliance, thereby ensuring that the device will conform to the surrounding anatomical structure.

When implanted, the central axis of the anchor is substantially aligned with the central axis of the gastrointestinal tract allowing chyme to pass through the device. Further, the device is resilient and sized to fit snugly within the intestine, yet compliant enough to allow the intestine to flex. Further, the wave pattern allows for radial compression of the anchor by a substantial amount thereby allowing it to fit within a working channel of catheter. Still further, the anchor presents a small surface area in contact with the intestine to minimize irritation.

The anchor can be removably attached within the body using mechanical fasteners such as barbs, surgical staples, and sutures and/or other fasteners, such as surgical adhesives. In an alternative embodiment, the anchor includes a fixed portion fixedly attached within the body and a connector configured to removably couple to a removable portion. At least one application includes the treatment of obesity and other intestinal disorders. For these applications, the anchor enables a sleeve, or barrier, to be securely implanted within the intestine. When implanted, the sleeve can act to block the uptake of food for that portion of the intestine covered by the sleeve.

Still further, the anchoring device is designed to minimize trauma to the tissue by providing sufficient flexibility and compliance. Thus, the anchoring device minimizes the likelihood of tissue erosion, while providing a solid anchoring point in the tissue. In fact, it is possible to vary the compliance of the anchoring devices quite readily by varying at least one of the material, shape, and/or dimensions.

One embodiment of a device configured for insertion within a natural lumen of a gastrointestinal tract of an animal body is shown in FIGS. 1A and 1B. The device includes a radial spring 100 including an elongated resilient member formed

about a central axis 115 and defining a central lumen. The radial spring 100 has a first end 105 and a second end 110 separated along the axis 115. Notably, the resilient member defines an oscillating pattern between the first end and the second ends 105, 110. In one embodiment, the radial spring 100 referred to generally as an anchor 100 includes a number of interconnected segments, legs, or struts 120', 120'' (generally 120). For example, the anchor 100 shown includes ten legs 120.

Beneficially, the wave anchor implanted in a natural lumen adjusts to the diameter of the surrounding anatomy. Exemplary relaxed diameter D_1 can range from a substantial diameter of about 25 to 45 mm, representing the size of an adult human's intestine. Advantageously, the radial spring is collapsible, capable of being compressed from the relaxed diameter D_1 to an exemplary compressed diameter D_2 of about 12 mm, or even less. Once inserted at a desired location within the natural lumen, the external force can be released, allowing the radial spring 100 to expand to a deployed state. Ideally, the deployed diameter D_3 of the radial spring 100 is between the relaxed diameter D_1 and the compressed diameter D_2 , such that the radial spring 100 provides a biasing outward force against the natural lumen.

A schematic diagram of a side view of the embodiment of the invention in a compressed state is shown in FIG. 1C. As shown in the figures, the geometry of the radial spring 100 lends itself to providing a substantial ratio of the diameters between the relaxed spring state and the compressed spring state. For example, this ratio of the diameters can be substantial, such as 2-to-1 to greater than 3-to-1. Further, the two ends 105, 110 of the radial spring 100 are separated by a distance L_1 in its relaxed state, and a slightly longer distance L_2 in its compressed state. A minimum length of the anchor can be selected to provide resistance to twisting, tending to keep the central axis of the anchor substantially aligned with the central axis of the natural lumen within which it is implanted. Further, a maximum length of the anchor can also be selected to ensure that the anchor is no longer than necessary, for example, to prevent blockage of the bile duct opening when implanted in the proximal duodenum. Exemplary relaxed lengths L_1 can range from about 1 to 2 inches. In some embodiments, the L_1 is between about 1.25 and 1.5 inches. Additionally, the wave anchor can be tapered so that one end is larger than the other end (e.g., the proximal opening is larger than the distal opening). Tapering in this

manner provides some resistance to the device moving proximally and reinforces engagement of any proximally-located barbs with the surrounding tissue. Thus, for an anchor implanted within the duodenum, the tapered profile would resist the anchor from migrating through the pylorus and into the stomach.

5 The outward force of the radial spring can be controlled by the dimensions and material used. In some applications, the radial spring 100 provides an anchor for securing a medical device within the gastrointestinal tract. For example, the anchor can be used for securing a feeding tube. In some applications, such as those intended for insertion within an intestine, the dilation force is sufficient to maintain
10 the anchor 100 in communication with the lumen of the intestine at all times, yet not too great to cause substantial irritation to the surrounding tissue. Further, the less dilation force of the anchor, the less likely the device will erode through the tissue.

 The compliance of the anchor 100 is selectable depending upon the number of nodes (pitch) and the diameter of the filament or wire used. Generally, the more
15 nodes included in the oscillating pattern, the more compliant the device will be. Additionally, the larger the filament or wire diameter, the less compliant the device will be. In some embodiments, such as laser-cut devices, both the width and thickness of the wire (e.g., rectangular profile) can be varied. Thus, the overall compliance of the device is determined at least from the wave pattern and the wire
20 shape and/or diameter. In some embodiments, the radial spring uses 0.012-0.020 inches diameter wire and at least five nodes.

 A perspective view of one embodiment of a wave anchor 200 is shown in FIG. 2A. A central lumen defined by the wave anchor 200 is aligned with the z-axis
25 215. The wave pattern is generally formed along an imaginary cylinder residing at a predetermined radial distance from the z-axis 215. The wave shape extends between maximum and minimum values along the z-axis 215. Notably, the wave anchor 200 can include a number of nodes, such as the five nodes illustrated. Generally, more than three nodes are used to define a central lumen. Also, as shown, the two ends of the element forming the wave anchor 200 can be joined or otherwise coupled
30 together at a joint 225. A weld, a bond, a mechanical crimp, a constricting sleeve, and combinations thereof can be used to form the joint 225.

The wave anchor 200 can be formed from a single filament, such as a single strand of solid wire. Alternatively, the wave anchor 200 can be formed from a number of filaments, such as a multi-stranded wire. Additionally, the individual strands of the multi-stranded wire can be selected to have different physical properties (e.g., diameter, resilience). Thus, the overall compliance and resilience of the wave anchor 200 can be controlled by selecting and combining individual strands having different properties. Further, the wave anchor 200 can be formed from a contiguous element forming the entire wave pattern (typically with one joint connecting two ends of an elongated member), or from a number of interconnected segments, together forming the wave pattern.

The wire and/or filaments can be made from any biologically compatible resilient material. For example, the material can be a metal, an alloy, a plastic, and combinations of these materials. In some embodiments, the material is a spring metal, such as stainless steel. In other embodiments, the material is an alloy. Preferably, the alloy is a superelastic alloy capable of withstanding the application of large forces and large movements and being able to recover from such large strains.

One example of a superelastic alloy is Nickel-Titanium (NiTi) compound commonly referred to as Nitinol. In one particular embodiment, the wave anchor 200 is made from a single Nitinol wire having a diameter from about 0.012 inches to about 0.020 inches. As the dilation force may not be sufficient to securely fasten the device to the local anatomy, some embodiments include anchoring features. For example, referring to FIG. 2B, a number of anchors 250 are coupled to the wave anchor 200. Thus, the ability of the wave anchor is to remain securely fastened to the body is enhanced by the addition of hooks and/or barbs 225.

FIGS. 3A through 3D are schematic diagrams of exemplary alternative embodiments of a five-node wave pattern. In FIG. 3A, the wave pattern is sinusoidal, extending along the z-axis between a maximum value of one-half of the device length (i.e., $+L/2$) to a minimum value of minus one half of the length (i.e., $-L/2$). As indicated, the pattern is traced over a radial distance of 2π radians along an imaginary cylinder having a radius equal to half the diameter of the device (i.e., $D/2$). FIG. 3B illustrates an oscillating pattern formed by linear segments of alternating pitch in which adjacent segments are joined together at their ends by a

curved segment. FIG. 3C illustrates a similar oscillating pattern formed by adjacent linear segments of alternating pitch in which adjacent segments are joined together at their ends by exaggerated curved segments. Such exaggerated curved segments can reduce the stresses experienced at the ends of the device, thereby reducing the chances of material fatigue. Finally, referring to FIG. 3D, one embodiment of the device includes a number of substantially linear segments of alternating pitch in which adjacent segments are joined together using a loop. The loop can be formed by bending the elongated member beyond π radians at the each of the nodes.

Advantageously, an anchor device formed from a wire is simple to manufacture. For example, the device can be formed from a single Nitinol wire fashioned into any of the annular waves shown in FIGS. 2 and 3. The two ends of the wire can be joined, or otherwise secured together to form a continuous wire structure. For example, the ends of the wire can be joined together using a weld, a bond, a mechanical crimp, a constricting sleeve, and combinations thereof. Notably, the shape, selection of materials, and construction of the device allow it to be radially compressed by a substantial amount without losing its original shape and dimensions. For example, the device can accommodate a very large diameter D_1 , such as the diameter of an adult human's intestine of up to about 45 mm, while advantageously allowing it to be radially compressed, or packed into a delivery system having a smaller diameter D_2 of 12 mm or less. Also, the radial force provided by the device can be controlled by the wire diameter from which it is made.

FIG. 4 is a schematic diagram of a side view of an embodiment of the invention in which an anchor is attached to a medical device. In the exemplary embodiment, the medical device is an elongated sleeve. As shown, the proximal end of the wave anchor 415 forms an annular ring having a wave-like shape formed about its perimeter. Preferably, the sleeve material proximal to the anchor 415 is cut back to match this shape of the anchor 415 (e.g., forming a "tulip" shaped end). Such a configuration facilitates the formation of a seal at the proximal end of the sleeve 400 and also allows for independent movement with flexure of the anchor 415. Thus, proximal ends of the different "petals of the tulip" can flex independently as the sleeve material 410 does not restrain them. Additionally, the

tulip-shaped proximal end, when installed, forms a secure seal along its entire perimeter when implanted in the gastrointestinal tract. Advantageously, such a tailored fit leaves no unsupported material between the edges of the device that food can get behind.

5 Generally, the proximal end of a sleeve device 400 is configured for reversible anchoring within the body. Notably, however, the sleeve device 400 does not require significant dilation force, as it is not supporting an opening into which it is placed (i.e., it is not a stent). Thus, the sleeve device 400 includes at least one anchoring, or securing device 415, attached to the sleeve 410. The purpose of the
10 proximal sleeve anchor 415 is primarily to hold the sleeve 100 in place. Additionally, the anchor 415 provides some radial force to ensure that the sleeve 410 provides a fluid seal against the local anatomy. Such a seal is particularly important for intestinal applications. In the intestine it is desirable to constrain the flow of chyme within the lumen of the sleeve device 400, reducing or eliminating the
15 likelihood of chyme passing around the device. Beneficially, the propulsive force of the stomach acts to push chyme into the device 400, ensuring that most of the chyme will enter the device.

As shown, the anchor device 415 can be fastened to the sleeve 410 at its proximal end. The material can be attached to the anchor 415 by mechanical and/or
20 chemical bonding, welding, and/or using other mechanical fasteners including sutures. In some embodiments the anchor 415 is attached to the sleeve 410 by sandwiching it between an inner and outer layer of the sleeve 410. Thus, in some embodiments, the material of the sleeve 410 extends around the radial exterior of the anchor device 415. In this manner, the material can be folded back to a length L_2
25 measured from the proximal end of the device 400. Generally, the length L_2 is greater than the axial extent of the anchor 415, L_1 . Advantageously, the double layer of material 410 extends a distance L_3 measured in a distal direction from the distal end of the anchor 415. The overlapping material 410 can be fastened together near the end of the overlap 420. For example, the two layers can be stitched together
30 along the line 420. Alternatively, the two layers can be chemically or thermally bonded together along the same line 420.

Generally, the sleeve is unsupported, having material properties selected to minimally irritate, or otherwise affect normal operation of the intestine. Thus, the material 410 is thin, light weight, supple and biocompatible. For example, the sleeve 410 can be formed from an elastomeric material such as urethane and/or
5 silicone rubber. Alternatively, the sleeve 410 can be formed from a substantially non-elastomeric material, such as a fluoropolymer and/or polyolefin. Some examples of fluoropolymers include PolyteTraFluoroEthylene (PTFE), expanded PTFE (ePTFE), Fluorinated Ethylene Propylene (FEP), PerFluoroAlkoxy (PFA), Ethylene TetraFluoroEthylene (ETFE), and PolyVinyliDene Fluoride (PVDF).
10 Some examples of polyolefins include polyethylene and polypropylene. The intestinal sleeve 410 is preferably thin-walled, unsupported and made of a flexible material that can be collapsed with minimal pressure from the outside. Thus, the unsupported, thin-walled material is naturally in a collapsed state and is opened only by pressure formed within the lumen of the sleeve 410. In some embodiments, the
15 thickness of the sleeve material is less than about 0.001 inch. The sleeve is preferably formed from a low friction material having a coefficient of friction of less than about 0.3. More preferably, the coefficient of friction is less than about 0.2. A low coefficient of friction facilitates insertion of the sleeve 410 within a body, and further facilitates passage of chyme therethrough.

20 Notably, as there is no network of struts with this design, the only substantial force on the surrounding tissue is along the outer surface area of the wire itself. For example, a five-node sinusoidal wave anchor having a length L_1 of 1 inch, and a diameter D_1 of about 1.8 inches formed from a 0.016 inches diameter wire provides a surface area of about 0.224 square inches. This results in a dramatic reduction in
25 the surface area of the tissue in contact with or otherwise affected by the anchor 415 (i.e., only the tissue in contact with the wire anchor), compared to typical, stent-type devices. It is therefore very unlikely that the ampulla of Vater 124, which empties into the duodenum, would be blocked by this anchor when implanted within the upper intestine in the vicinity of the ampulla of Vater 124, even though the sleeve
30 410 extends across and beyond the ampulla of Vater 124. Longer and more stent-like devices would be more likely to lie over the ampulla of Vater 124 potentially blocking it. More generally, the sleeve can be anchored at other locations within the

gastrointestinal tract. For example, the anchor can be placed in the stomach with the sleeve extending into the intestine. Alternatively or in addition the sleeve can be anchored in the duodenum below the ampulla of Vater 124, or even in more distal portions of the intestine, such as the jejunum or ileum.

5 Such light-weight material is prone to reflux in the proximal direction. In some instances, the reflux results in a part of the material 410 extending beyond the proximal end of the anchor 415. This situation is generally undesirable resulting from back pressure originating in the distal intestine. Beneficially, the overlap described above provides additional strain relief at the proximal end of the sleeve
10 410 to resist such reflux.

A cross-section of a portion of the proximal end of an unsupported sleeve including a proximal anchor is shown in FIGS. 5A – 5C. The proximal anchor 450 can be sandwiched between two layers of the sleeve material 410. As shown, the proximal end of the sleeve 410 can be folded back upon itself, substantially
15 enclosing the anchor 450 therein. An extended double layer of the sleeve 455 can be continued for a predetermined length extending distally from the distal end of the anchor 450. Such a double layer can provide additional strain relief. To secure the sleeve configuration, the two layers 410, 455 can be attached together. For example, the layers 410, 455 can be attached using sutures, staples, and/or chemical or
20 thermal bonding 420. In an alternative embodiment shown in FIG. 5B, the sleeve 410 can be folded forming more than two layers 455, thus providing even greater support and rigidity than the double layer. Still further, the sleeve 410 can be folded about a supporting member 460.

Referring now to FIG. 6, one embodiment of the invention is shown
25 implanted within a natural lumen of a gastrointestinal tract of an animal body. In the exemplary implantation, an anchor 108 anchors an unsupported flexible sleeve 110 within the duodenum 106. In particular, the anchor is placed within the duodenal bulb 119, which is located just distal to a pylorus 105. At least one advantage to anchoring in the duodenal bulb 119 is that there is relatively less motion compared
30 to other parts of the duodenum 106. Further, the motion in the duodenal bulb 119 tends to be limited contractions, rather than contractions and linear movements. Still further, the surrounding muscular tissue of the duodenal bulb 119 is relatively thick,

thinning as one moves away from the pylorus 105, facilitating attachment of the anchor 108. The thick tissue is particularly advantageous in anchors using barbs.

At least one advantage resulting from anchoring at the duodenal bulb 106 is that the pylorus 105 is allowed to open and close normally. As described above, the length of the anchor 108 is minimal to ensure that the ampulla of Vater 124 is not blocked. This distance in an average adult human between the pylorus 105 and the ampulla of Vater 124 is at least about 2 inches. Thus, the length of the anchor 108 is preferably less than about 2 inches. Additionally, as described above a flare can be provided at the proximal end of the anchor 108 functioning as a stop against the distal side of the pylorus 105 to resist reflux of the device 110 into the stomach 102. The flare also helps direct chyme flowing from the stomach 102 into the center of the anchor 108 and sleeve 110. Still further, the flare helps reinforce engagement of any proximally-located barbs with the surrounding tissue

FIG. 7 is a more-detailed cross-sectional diagram of one embodiment of the invention inserted within a natural lumen. Generally, the natural lumen 610 is formed within the interior of a hollow organ, such as the intestine 600. The cross-section of the intestine 600 includes a number of different layers. For example, the intestine 600 includes muscular layer 605 including muscular tissue for aiding in the passage of food. Additionally, the intestine includes a mucosal layer 615 along the interior surface of the lumen. In the intestine, the mucosal layer 615 is a mucosa layer formed of loose tissue. A gastrointestinal implant 620, similar to the one shown in FIG. 4 is shown secured within the intestine 600. Thus the gastrointestinal implant 620 includes a wave anchor 630 coupled to the proximal end of an elongated sleeve 625. The proximal end of the gastrointestinal implant 620 includes a number of barbs arranged in at least two layers: a proximal layer of barbs 640', 640'' (generally 640) located near the proximal end of the anchor 630; and a distal layer of barbs 645', 645'' (generally 645). In some embodiments, the distal barbs 645 are located near the distal end of the anchor 630. In other embodiments, distal barbs 646', 646'' (generally 646) are located closer to the proximal end of the anchor 630 and can even be just distal to the proximal barbs 640. As shown, the barbs 640, 645 preferably penetrate the mucosa layer 615 extending into but not through the muscular layer 605.

In more detail, referring now to FIG. 8A, barbs 740, 745 can be attached directly to the wave anchor 730. For example, one or more barbs 740, 745 can be fastened to one or more of the legs or struts 730 of the wave anchor. The barbs 740, 745 can be fastened to the struts 730 by welding, bonding, or crimping means.

5 Additionally, the barbs 740, 745 can be fastened to the struts 730 using a mechanical fastener, such as a clasp or splice 700. In some embodiments, the barbs 740, 745 can be formed contiguous with the struts 730. Alternatively, or in addition, the barbs 740, 745 can be molded onto the struts 730. For example, barbs can be formed by injection molding a first material onto the supporting struts 730. The
10 barbs can be injection molded onto a completely formed anchor 730, and/or injection molded onto a substrate, such as a wire, that is later formed into the anchor 730. Such injection molding techniques are well adapted to forming erodible barbs of a first material upon the supporting anchor 730 formed from a second material, such as stainless steel or Nitinol. For example, the erodible barbs can be formed
15 from PolyLactide (PLA), PolyGlycolic Acid (PGA), and/or PolyparaDioxanone (PDS). Advantageously, depending on the configuration of the erodible materials, they can be formed to erode after a predetermined period of implantation. In some embodiments, a large number of barbs 740, 745 (e.g., 80 barbs) are provided around the wave anchor.

20 In some embodiments, the barbs 740, 745 reside within a plane containing the central axis of the anchor 730. Thus, the barbs extend outward containing an axial component and a radial component, but not a transverse component. Alternatively, the barbs can extend outward from the central axis in a direction having a transverse component. For example, the barbs could reside substantially in
25 a plane perpendicular to the central axis. Barbs having a transverse component can prohibit twisting of the anchor about its central axis.

The barbs 740, 745 can be fabricated from a shape-memory material, or a superelastic material. For example the barbs can be formed from a Nitinol wire having a diameter between about 0.016-0.025 inches. The barbs 740, 745 can also
30 be formed from a rigid, yet resilient material such as stainless steel. Preferably, the barbs 740, 745 are designed to penetrate into the surrounding intestine wall, but not through it. Accordingly, the length of the exposed barb 740, 745 is controlled

depending on the application. For example, for placement within the upper intestine, the barbs 740, 745 are approximately 3 mm long and extend outward from the device at an angle of about 45 degrees to a height (i.e., penetration depth) of about 2 mm. This ensures that the barbs 740, 745 penetrate the mucosa layer of the intestine and attach to the underlying tissue.

The angle of each of the barbs 740, 745 can also be varied depending on the desired effect. In some embodiments, proximal barbs 740 extend from the anchoring device 630 in a proximal direction; whereas, distal barbs 745 extend from the anchoring device 630 in a distal direction. An angle is defined between the axis of each barb 740, 745 and the surface of the wave anchor. In some embodiments the distal barbs 745 form a first angle θ_1 , while the proximal barbs 740 define a second angle, θ_2 . In some embodiments, the first angle is a shallow angle, such as $\theta_1 = 10$ degrees, while the second angle is substantially steeper (e.g., closer to 90 degrees). In other embodiments, both angles are about 45 degrees. In addition to the angle, the barb heights h_1 , h_2 control the respective depths of penetration into the surrounding tissue. For example for intestinal applications, a height of about 2 mm is preferred to penetrate into the muscular layer of the intestine without necessarily puncturing the outer surface of the intestine.

A more detailed schematic diagram of the tip of one of the distal barbs 745 is illustrated in FIG. 8B. Notably, the end surface of the barb 745 can be fashioned with a predetermined profile. For example, the tip of the barb 760 can be blunt, tapered, and/or pointed. Additionally, the tip of the barb 760 can be directionally pointed, as shown. Thus, an angle formed between the axis of the barb 745 and its end surface area α is selected to provide a sharp profile along its leading edge 755 and a blunt profile along its trailing edge 760. Thus, movement of the distal barb 745 in a proximal direction will not pierce the surface of the natural lumen; whereas, movement in a distal direction will result in the leading edge 755 tending to pierce the tissue of the natural lumen. Such a directional profile can aid in implanting the device at a desired location. That is, the device can first be placed distal to the desired location, then drawn proximally to the desired location and finally pushed distally again to set the distal barbs 745 into the tissue.

FIGS. 8C-8D are schematic diagrams of one the embodiment of the invention being inserted within a natural lumen. Generally, during implantation, the distal barbs are set first. The compressed device is inserted into a predetermined location with the lumen and the distal end of the anchor is released allowing the
5 distal barbs to come into contact with the tissue of the lumen. Then, as described above, distal movement of the device along the axis of the lumen causes the distal barb 745 to insert itself into the tissue 750. Once set, the proximal end of the anchor is released from its compressed state allowing the proximal barbs to pierce into the surrounding tissue 750. As the movement of the barb is substantially perpendicular
10 to the surface of the lumen, the high angle results in the barb approaching the surface tissue at a substantially perpendicular angle. Once implanted, the barbs 740, 745 operate to secure the device to the surrounding tissue 750 resisting axial movement along the lumen, and also securing the anchor during radial expansion of the lumen.

15 To remove the anchoring device, it can be grasped at its proximal end and collapsed radially. Further, the radially collapsed anchoring device itself can be drawn into a sleeve or catheter for removal. Thus, the proximal barbs 740 being more vertical are easier to remove from the tissue 750 as the proximal end of the device is radially collapsed. Once the proximal end is collapsed, the device can be
20 pulled proximally allowing the distal barbs 745 to slide out of the tissue 750 due to their lower angle. In some embodiments, the proximal and distal barbs 740, 745 are formed having substantially the same angle.

In some embodiments, the barbs include hooks 770, 775 to grasp the tissue of the surrounding anatomy, such as those shown in FIG. 8E. The hooks 770, 775
25 can be attached to one or more legs 730 of the anchor. For example, the hooks 770, 775 can be welded, bonded, or crimped to one or more of the legs 730 of the device. As shown, the hooks 770, 775 can be formed from a single filament of wire attached to one of the legs 730 using a crimp sleeve 760. Thus, different materials can be used for hooks 770, 775 and the anchor itself. Alternatively, the hooks can be
30 formed from different material, with each hook independently being attached to the leg 730.

In some embodiments, the hooks 770, 775 are fabricated from a shaped-memory material, such as Nitinol wire. Preferably, the shaped-memory alloy is set for phase transition at around body temperature. Thus, the hooks 770, 775 can be cooled before insertion and configured in a substantially straight configuration to
5 pierce the tissue of the surrounding anatomy. Then, when inserted into the tissue, a resulting raise in temperature to body temperature leads to a phase transition resulting in the hooks 770, 775 re-shaping into hook-shape to grasp the tissue. For removal, the anatomy in the region of the hooks 770, 775 can be cooled below body temperature, and below the phase-transition temperature to again straighten the
10 hooks 770, 775 thereby facilitating removal from the tissue. For example, the hooks 770, 775 can be cooled with cold-water injection to soften the hooks 770, 775 for installation and also for removal from the body. The hooks 770, 775 can also be Nitinol, superelastic wires that are flattened during delivery and when released, they spring into the tissues.

15 If shape memory, they lay flat at room temperature to be collapsed for easy insertion into the body. The hooks take shape at body temperature to anchor into the tissue. If superelastic, they are forced flat and placed in a tube for loading and the anchors spring to shape as they are pushed out of the delivery tube. Fig. 4C illustrates pre-deployed barbs. Fig. 4D illustrates deployed barbs and Fig. 4E
20 illustrates the collapsed system for delivery.

FIG. 9 is a schematic diagram of a side view of an alternative embodiment of the invention 900 including a wave anchor 920 coupled to the proximal end of an elongated sleeve 910. In some embodiments securing devices 940', 940'' are provided on the sleeve 910, not necessarily at its proximal anchor 920. For example,
25 as shown in FIG. 9, a sleeve device 900 includes a flexible sleeve 910 having a first anchoring device 920, such as a wave anchor, at its proximal end. In some embodiments, the wave anchor 920 can maintain its position within the gastrointestinal tract by relying on its radial force exerted upon the surrounding tissue. Alternatively, the wave anchor 920 can include one or more anchoring
30 elements, such as a number of barbs 930 similar to those described above in relation to FIGS. 8A-8E, to further secure the proximal end of the device 900.

Additional anchoring elements 940', 940'' can be positioned along the flexible sleeve 910, separate from the wave anchor 920. For example, anchoring strips 940', 940'' (generally 940) can be attached to the sleeve 910. Each anchoring strip includes one or more barbs. For example, a strip 940 can include multiple
5 barbs linearly arranged along the strip 940.

FIGS. 10A-10B are more detailed schematic diagrams of one embodiment of sleeve barbs 940. An anchoring strip 1000 includes a mounting frame 1010 and a number of barbs 1020, each of the barbs 1020 coupled at one end to the frame 1010. Preferably, the strip 1000 is compliant and flexible. For example, the strip 1000 can
10 be formed from a thin strip of shape memory material, such as Nitinol, or stainless steel, having a thickness 't' selected to ensure the desired flexibility. In some embodiments, the barbs 1020 can be attached to the mounting frame 1000 by mechanical fasteners, welding, and/or chemical bonding. In other embodiments, the barbs 1020 can be formed from the material of the strip 1000. For example, the
15 barbs can be formed by cutting a shape, such as a triangle into strip 1000, then bending the triangles outward from the strip, such that the barbs 1020 will engage the surrounding tissue when implanted. To ensure that the anchoring strip 1000 is flexible, the width of the strip 'W₁', including the width measured from the edge of the strip 1010 to the edge of the barb 'W₂' is controlled to a minimum distance.

In some embodiments, all of the barbs 1020 of a strip 1000 are oriented in
20 the same direction to prevent movement in a one direction. In this manner multiple anchoring elements 1000 can be mounted to a single sleeve 910, with all of the anchoring elements 1000 providing barbs 1020 substantially aligned in the same direction. Alternatively, the orientations of the multiple anchoring elements 1000
25 can be varied, such that some barbs 1020 are aligned in one direction, while other barbs 1020 are aligned in another direction. In other embodiments, the barbs are formed substantially perpendicular to the surface of the strip 1010 to prevent motion in either direction.

Alternatively, the barbs can be formed with different orientations on the
30 same strip as shown in FIGS. 11A and 11B. Thus, an anchoring device 1100 includes a mounting strip 1110 containing a first barb 1120 oriented in a first direction and a second barb 1130 oriented in a different (e.g., opposing) direction.

In other embodiments, as shown in FIGS. 12A and 12B, an anchoring strip 1200 can be formed having a mounting strip 1210 formed from a moldable material, such as a polymer. In this manner, one or more barbs 1220 can be attached to the mounting strip 1210 by including a portion that is anchored within the strip 1210 itself. For example, as illustrated, the barbs 1220 can be formed from a segment of wire, such that a first portion of the wire segment is embedded within the mounting strip 1210, while a second portion of the wire segment protrudes from the mounting strip 1210, being adapted to engage the surrounding tissue when implanted.

An advantage of the wave design is the ability to form an anchor having a very flat compliance curve over a very long range of diameters. In general, referring now to FIG. 13, exemplary compliance curves show the radial force exerted by different devices as they are radially compressed. This means that the force against the tissue is substantially constant, even as the intestine contracts. Such a compliant device is less traumatic to the surrounding tissues. Exemplary spring rates of the above-described wave anchors are an order of magnitude less than mesh-type stents. Additionally, the resulting spring rates of the wave anchors are about half that of a typical Nitinol stent made from tubing. Further, the range of motion of commercial stents is less than about 0.5 inches whereas the wave anchors can operate in a range of up to about 1.5 inches with a substantially flat compliance curve. Exemplary test results are provided in Table 1 for known stent and for a number of other devices including wave anchors.

Table 1. Test Results

	Mesh-type Stent	Wave-0.014	Wave-0.016	Laser-cut 1	Laser-cut 2
Spring Rate (lbs./inch):	1.714	0.0438	0.0722	0.168 (long) 0.240 (short)	0.253
Approx. Range (inches):	0.3	1.0	1.0	0.5	0.35

25

Depending upon the application, it may be necessary at times to periodically remove the medical device (e.g., sleeve) from the body. For example, an intestinal sleeve may be periodically removed to provide a rest period from material contact

with the intestine, to adjust the therapy with a longer or shorter sleeve, and/or to replace the sleeve material before its useful life is over. Additional means to facilitate insertion, removal, and reinsertion, a two-part anchor includes a first portion fixedly attached within the body and a second portion adapted to removably engage the first portion. Thus, the first portion or permanent anchor can be fixedly attached (i.e., implanted) within a patient. Thus, a permanent anchor can be fastened to the patient using mechanical and/or chemical fasteners. Additionally, the permanent anchor can be configured to promote tissue in-growth to secure it within the body.

10 A second fastener can then be used to removably engage a medical device to the permanent anchor. For example, the second fastener can include a clip 1405 as illustrated in FIGS. 14A and 14B. Such a design enables a medical practitioner to easily fasten (e.g., “click”) the medical device into and/or out of its position. Additionally, should a device, such as an intestinal sleeve become obstructed, it would be advantageous to allow the sleeve to dislodge itself and pass through the patient thereby avoiding potentially catastrophic consequences. Accordingly, in some embodiments, the fastening means release when the linear forces acting upon it increase sufficiently above a threshold to avoid harming the surrounding tissue. Thus, the permanent anchor remains in place, while the fastening means are designed to break away at a predetermined force, such as about 2 lbs. Once the device breaks away, it can be withdrawn (e.g., through the esophagus), or can pass normally through the bowel, while the permanent anchor remains in place, ready to accept another device.

25 The clip, or clasp 1405 can be formed by a loop defined at least in part by a spring member 1410. The loop also includes an opening 1415 that can be expanded by flexing the spring member 1410. Preferably the opening 1415 is normally closed when the spring member 1410 is not being flexed. Thus, a feature of a mating device, such as the sleeve, can be inserted into the clasp 1405, thereby securing the sleeve to the permanent anchor 1400 as described above. For example, the proximal end of the sleeve can include or more loops 1420 such as loops formed by the nodes of a wave anchor. Upon removal, the one or more loops 1420 can be extracted from the clasp 1405 allowing the sleeve to be separated from the permanent anchor 1400

and removed from the body. The permanent anchor 1400 remains within the body and can be used again in a similar fashion. In an alternative embodiment, the removable device includes one or more clasps configured to engage a feature, such as a loop, of the permanent anchor 1400.

5 In an alternative embodiment of a two-piece anchor can be fastened together using a magnetic fastener. For example, a permanent anchor can be provided with one or more magnets. A second, removable anchor can be provided with corresponding magnetically-attracted features configured to attach to the one or more magnets of the permanent anchor. Thus, the permanent and removable
10 anchors are removably coupled together via magnetic attraction. Alternatively, the removable anchor can be provided with one or more magnets and the permanent anchor provided with corresponding magnetically-attracted features, the two anchor removably coupled together via magnetic attraction. Still further, each of the permanent and removable anchors can be configured with both magnets and
15 magnetically-attracted features configured to magnetically couple with corresponding features of the other anchor.

 In one embodiment illustrated in FIGS. 15A-15E, a first anchor component 1500 can be secured to an internal lumen of the gastrointestinal tract using any of the above-described means. The first anchor component 1500 includes a first and a
20 second magnets 1505', 1505". The second anchor component 1510 can be secured to a medical device, such as an elongated sleeve. The second anchor component 1510 includes a first and a second magnetically-attracted feature 1515', 1515". The two anchor components 1500, 1510 when brought into proximity with each other as shown in FIG. 15C magnetically couple together as described above. A side view
25 and an end view of the coupled anchors 1500, 1510 are respectively shown in FIGS. 15D and 15E.

 In some embodiments, the wave anchor is formed from a wire or cable strand. In other embodiments, as shown in FIGS. 16 and 17, the wave anchor can be cut from tubular stock. For example, the wave anchor can be laser cut from a
30 Nitinol tube. Advantageously, the wave pattern can be formed so that a number of substantially identical wave anchors can be cut from the same tube with minimal waste. Further, mechanical fasteners, such as barbs or staples can also be cut from

the same tube, so that the wave anchor and the barbs are contiguous. When formed in this manner, the barbs would be bent or angled away from the axis of the wave anchor to engage muscular tissue as described above generally.

While this invention has been particularly shown and described with
5 references to preferred embodiments thereof, it will be understood by those skilled in the art that various changes in form and details may be made therein without departing from the scope of the invention encompassed by the appended claims.

CLAIMS

What is claimed is:

1. A gastrointestinal implant device comprising:
an unsupported, flexible sleeve, open at both ends, and adapted to
5 extend into the intestine; and
a wave anchor coupled to a proximal portion of the sleeve, and
adapted for attachment within an animal body.
2. The gastrointestinal implant device of claim 1, wherein the wave anchor is
10 adapted for attachment in the intestine.
3. The gastrointestinal implant device of claim 2, wherein the wave anchor is
adapted for attachment in the duodenum.
- 15 4. The gastrointestinal implant device of claim 2, wherein the wave anchor is
adapted for attachment in the duodenal bulb.
5. The gastrointestinal implant device of claim 1, wherein the wave anchor is
adapted for removable attachment in the intestine.
- 20 6. The gastrointestinal implant device of claim 1, wherein the wave anchor
includes an elongated resilient member formed about a central axis, the wave
anchor having a first end and a second end and defining a central lumen
therebetween, the resilient member defining an oscillating pattern about the
25 central axis alternating between the first and second ends.
7. The gastrointestinal implant device of claim 6, wherein the wave pattern has
at least four oscillations.
- 30 8. The gastrointestinal implant device of claim 6, wherein the resilient member
comprises a material selected from the group consisting of: metals, alloys,
plastics, and combinations thereof.

9. The gastrointestinal implant device of claim 6, wherein the resilient member comprises a super elastic alloy.
- 5 10. The gastrointestinal implant device of claim 9, wherein the super elastic alloy is a Nickel-Titanium alloy.
11. The gastrointestinal implant device of claim 6, wherein the resilient member includes a plurality of strands.
- 10 12. The gastrointestinal implant device of claim 11, wherein some of the plurality of strands have different physical properties.
13. The gastrointestinal implant device of claim 6, wherein the resilient member comprises a first length having an associated physical property and a second length having a different associated physical property.
- 15 14. The gastrointestinal implant device of claim 13, wherein the physical property is resiliency.
- 20 15. The gastrointestinal implant device of claim 13, wherein the physical property is thickness.
16. The gastrointestinal implant device of claim 13, wherein the physical property is cross-sectional profile.
- 25 17. The gastrointestinal implant device of claim 1, wherein the wave anchor defines a central lumen diameter that is variable between a relaxed state and a compressed state, the ends being separated by an axial length, wherein the ratio of the implanted axial length to diameter is at least about one.
- 30

18. The gastrointestinal implant device of claim 17, wherein the relaxed diameter is about 45 millimeters.
- 5 19. The gastrointestinal implant device of claim 1, further comprising a feature for attaching the wave anchor within a natural lumen of the gastrointestinal tract.
- 10 20. The gastrointestinal implant device of claim 19, wherein the feature for attaching comprises an interference fit formed between the wave anchor and the natural lumen.
- 15 21. The gastrointestinal implant device of claim 20, wherein the feature for attaching is selected from the group consisting of: mechanical fasteners, chemical fasteners, and combinations thereof.
- 20 22. The gastrointestinal implant device of claim 21, wherein the chemical fastener includes a surgical adhesive.
23. The gastrointestinal implant device of claim 21, wherein the mechanical fasteners are selected from the group consisting of: barbs, sutures, staples, and combinations thereof.
- 25 24. The gastrointestinal implant device of claim 20, wherein the implant device is attached using a first plurality of barbs.
- 30 25. The gastrointestinal implant device of claim 24, wherein each of the plurality of barbs comprises an elongated member, attached at one end to the wave anchor, the other end extending generally outward from the central axis, the barb sized to engage muscular tissue of the surrounding intestine.
26. The gastrointestinal implant device of claim 24, wherein the plurality of barbs are erodible.

27. The gastrointestinal implant device of claim 24, wherein the first plurality of barbs are axially distributed and located substantially at one of the ends of the device.
- 5
28. The gastrointestinal implant device of claim 27, further comprising a second plurality of axially-distributed barbs located between the first plurality of barbs and the other end of the device.
- 10 29. A method of treatment comprising the steps of:
 providing an unsupported, flexible sleeve, open at both ends;
 extending at least one end of the sleeve into the intestine of an animal body; and
 attaching a proximal portion the sleeve within the animal body using
15 a wave anchor.
30. The method of claim 29, wherein attaching comprises attaching the wave anchor in the intestine.
- 20 31. The method of claim 30, wherein attaching comprises attaching the wave anchor in the duodenum.
32. The method of claim 30, wherein attaching comprises attaching the wave anchor in the duodenal bulb.
- 25 33. The method of claim 29, wherein the wave anchor is adapted for removable attachment in the intestine.
- 30 34. The method of claim 29, wherein the wave anchor includes an elongated resilient member formed about a central axis, the wave anchor having a first end and a second end and defining a central lumen therebetween, the resilient

member defining an oscillating pattern about the central axis alternating between the first and second ends.

- 5 35. The method of claim 34, wherein the wave pattern has at least four oscillations.
- 10 36. The method of claim 34, wherein the resilient member comprises a material selected from the group consisting of: metals, alloys, plastics, and combinations thereof.
37. The method of claim 34, wherein the resilient member comprises a shape-memory alloy.
- 15 38. The method of claim 37, wherein the shape-memory alloy is a Nickel-Titanium alloy.
39. The method of claim 34, wherein the resilient member includes a plurality of strands.
- 20 40. The method of claim 39, wherein some of the plurality of strands have different physical properties.
- 25 41. The method of claim 34, wherein the resilient member comprises a first length having an associated physical property and a second length having a different associated physical property.
42. The method of claim 41, wherein the physical property is resiliency.
43. The method of claim 41, wherein the physical property is thickness.
- 30 44. The method of claim 41, wherein the physical property is cross-sectional profile.

45. The method of claim 29, wherein the wave anchor defines a central lumen diameter that is variable between a relaxed state and a compressed state, the ends being separated by an axial length, wherein the ratio of the implanted axial length to diameter is at least about one.
- 5
46. The method of claim 45, wherein the relaxed diameter is about 45 millimeters.
- 10 47. The method of claim 29, further comprising providing a feature for attaching the wave anchor within a natural lumen of the gastrointestinal tract.
48. The method of claim 47, wherein the feature for attaching comprises an interference fit formed between the wave anchor and the natural lumen.
- 15
49. The method of claim 47, wherein the feature for attaching is selected from the group consisting of: mechanical fasteners, chemical fasteners, and combinations thereof.
- 20 50. The method of claim 49, wherein the chemical fastener includes a surgical adhesive.
51. The method of claim 49, wherein the mechanical fasteners are selected from the group consisting of: barbs, sutures, staples, and combinations thereof.
- 25
52. The method of claim 29, wherein the implant device is attached using a first plurality of barbs.
53. The method of claim 52, wherein each of the plurality of barbs comprises an elongated member, attached at one end to the wave anchor, the other end extending generally outward from the central axis, the barb sized to engage muscular tissue of the surrounding intestine.
- 30

54. The method of claim 52, wherein the plurality of barbs are degradable.
55. The method of claim 51, wherein the first plurality barbs are axially
5 distributed and located substantially at one of the ends of the device.
56. The method of claim 55, further comprising a second plurality of axially-
distributed barbs located between the first plurality of barbs and the other
end of the device.
- 10 57. A gastrointestinal implant device comprising:
a first annular element configured for insertion into a natural lumen
of a gastrointestinal tract of an animal;
a fastener for fixedly securing the first annular element within the
15 natural lumen;
a gastrointestinal implant; and
a connector for removably coupling between the first annular element
and the gastrointestinal implant.
- 20 58. The gastrointestinal implant of claim 57, wherein the fastener is selected
from the group consisting of: mechanical fasteners; chemical fasteners; and
combinations thereof.
59. The gastrointestinal implant of claim 58, wherein the mechanical fasteners
25 are selected from the group consisting of: barbs; sutures; staples; and
combinations thereof.
60. The gastrointestinal implant of claim 57, wherein the gastrointestinal implant
30 comprises a second annular element.

61. The gastrointestinal implant of claim 60, wherein the second annular element comprises an unsupported, flexible sleeve having a proximal end and a distal end defining a central lumen therebetween.
- 5 62. The gastrointestinal implant of claim 57, wherein the connector comprises a clasp attached to one of the first annular element and the gastrointestinal implant and configured for engaging a feature of the other of the first annular element and the gastrointestinal implant.
- 10 63. The gastrointestinal implant of claim 57, wherein the connector is actuated by magnetic attraction.
64. The gastrointestinal implant of claim 57, wherein the connector comprises a magnet attached to one of the first annular element and the gastrointestinal
15 implant and configured for engaging a feature of the other of the first annular element and the gastrointestinal implant.
65. A method of treatment comprising the steps of:
inserting a first annular element into a natural lumen of a
20 gastrointestinal tract of an animal;
fixedly securing the first annular element within the natural lumen;
providing a gastrointestinal implant; and
removably coupling the gastrointestinal implant to the first annular
element.
- 25 66. The method of claim 65, wherein the step of fixedly securing the first annular element comprises using a fastener is selected from the group consisting of: mechanical fasteners, chemical fasteners, and combinations thereof.
- 30 67. The method of claim 66, wherein the mechanical fastener is selected from the group consisting of: barbs; sutures; staples; and combinations thereof.

68. The method of claim 67, wherein the gastrointestinal implant comprises a second annular element.
- 5 69. The method of claim 68, wherein the second annular element comprises an unsupported, flexible sleeve having a proximal end and a distal end defining a central lumen therebetween.
70. The method of claim 65, wherein the step of removably coupling comprises:
10 providing a clasp;
 attached the clasp to one of the first annular element and the gastrointestinal implant; and
 engaging with the clasp a feature of the other of the first annular element and the gastrointestinal implant.
- 15 71. The method of claim 70, wherein the step of removably coupling comprises:
 providing a connector actuated by magnetic attraction;
 coupling the connector to one of the first annular element and the gastrointestinal implant; and
20 magnetically engaging with the connector a feature of the other of the first annular element and the gastrointestinal implant.

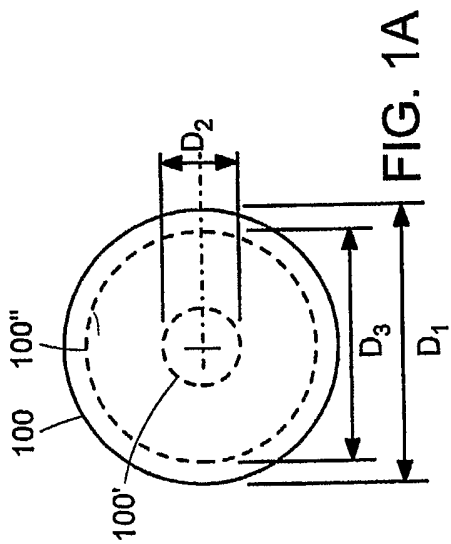

FIG. 1A

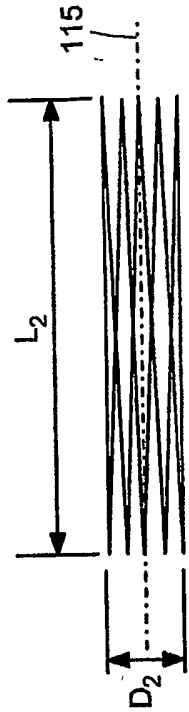

FIG. 1C

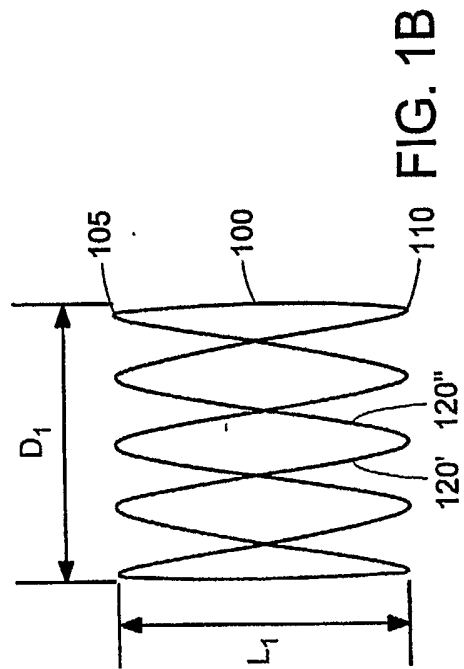

FIG. 1B

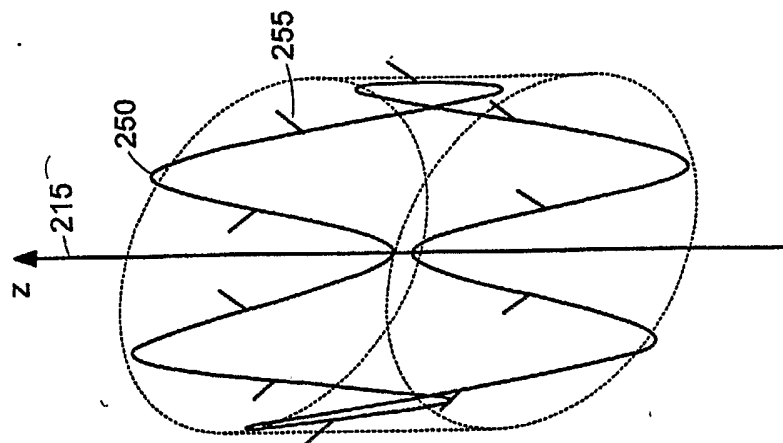

FIG. 2B

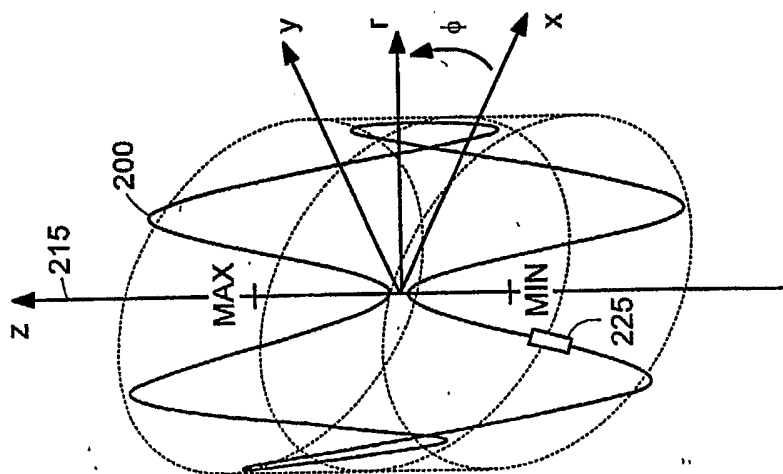
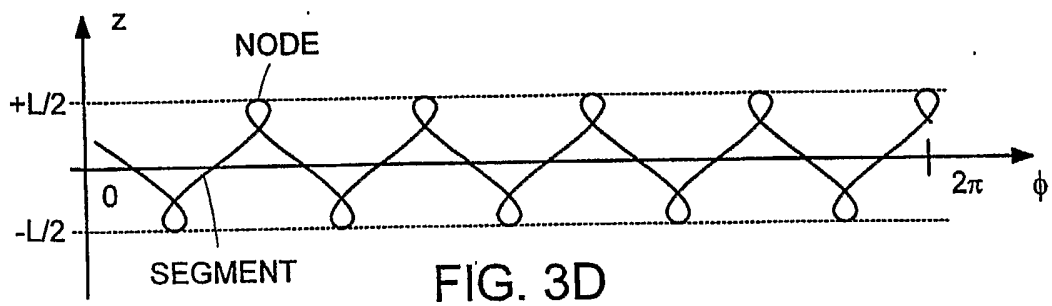
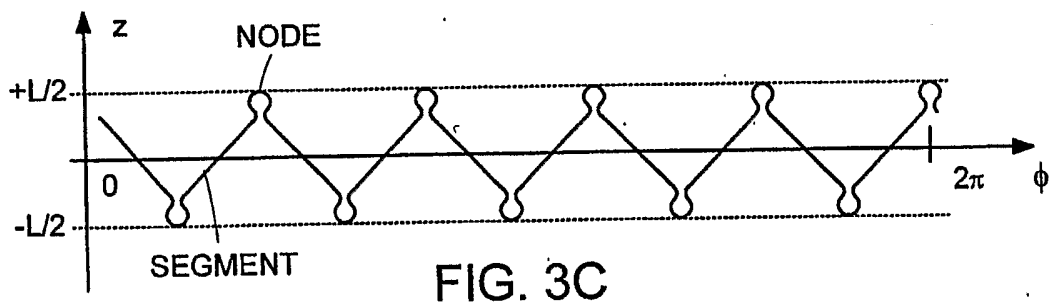
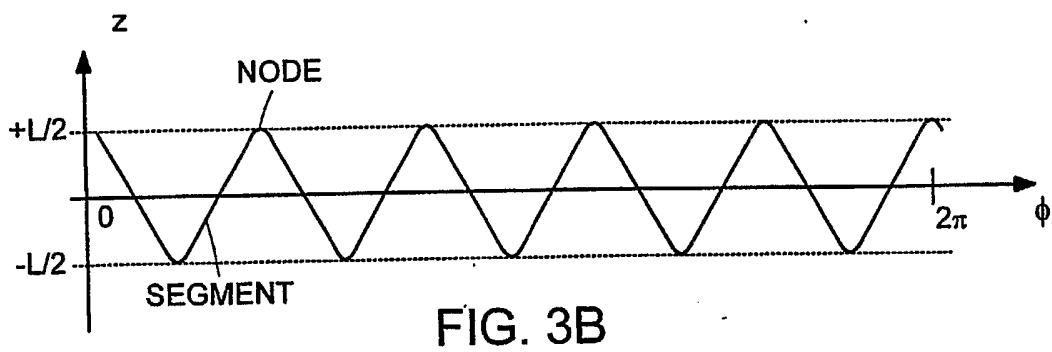
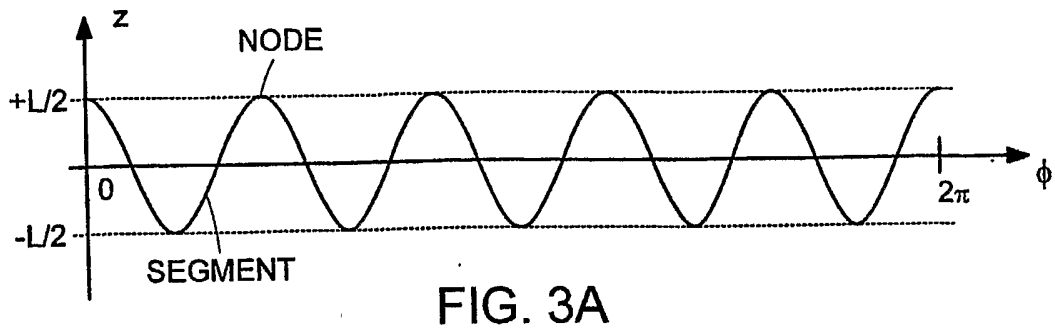

FIG. 2A

3/21



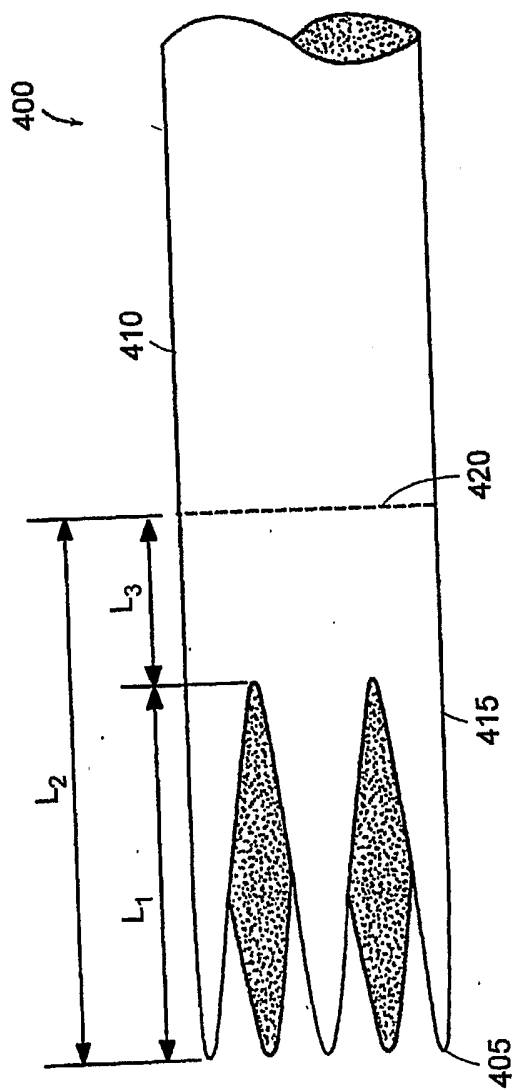

FIG. 4

5/21

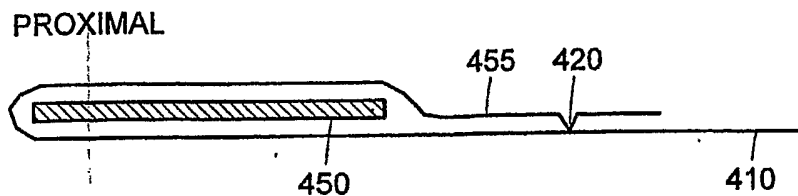

FIG. 5A

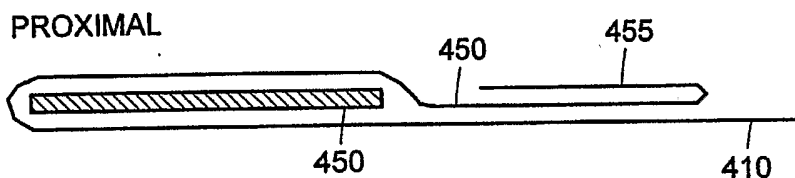

FIG. 5B

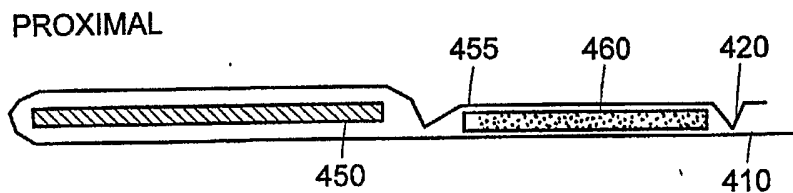

FIG. 5C

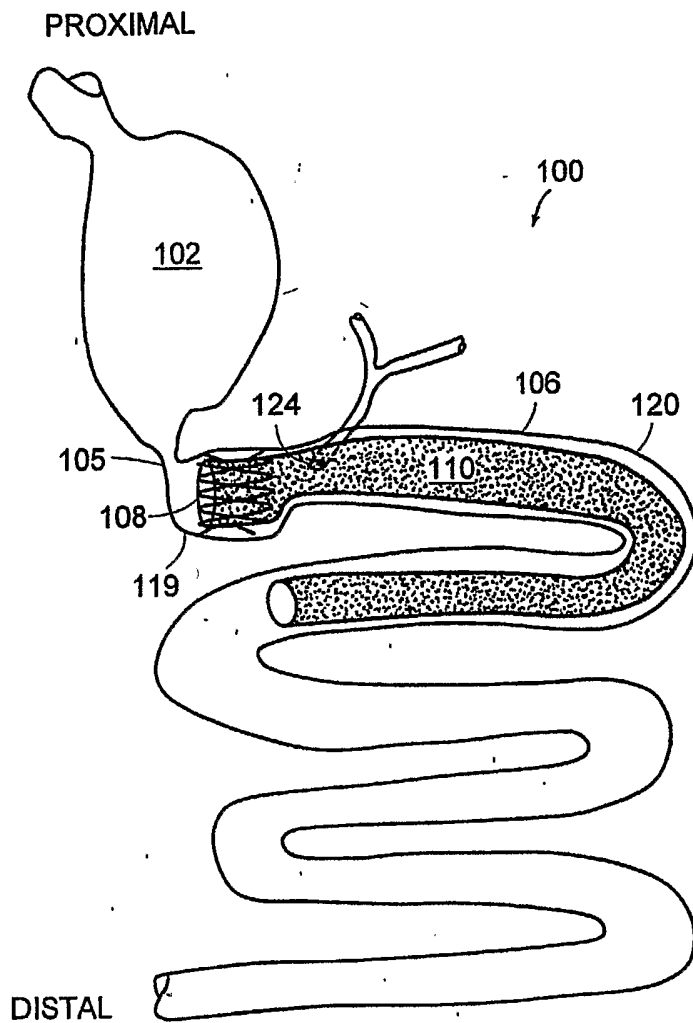

FIG. 6

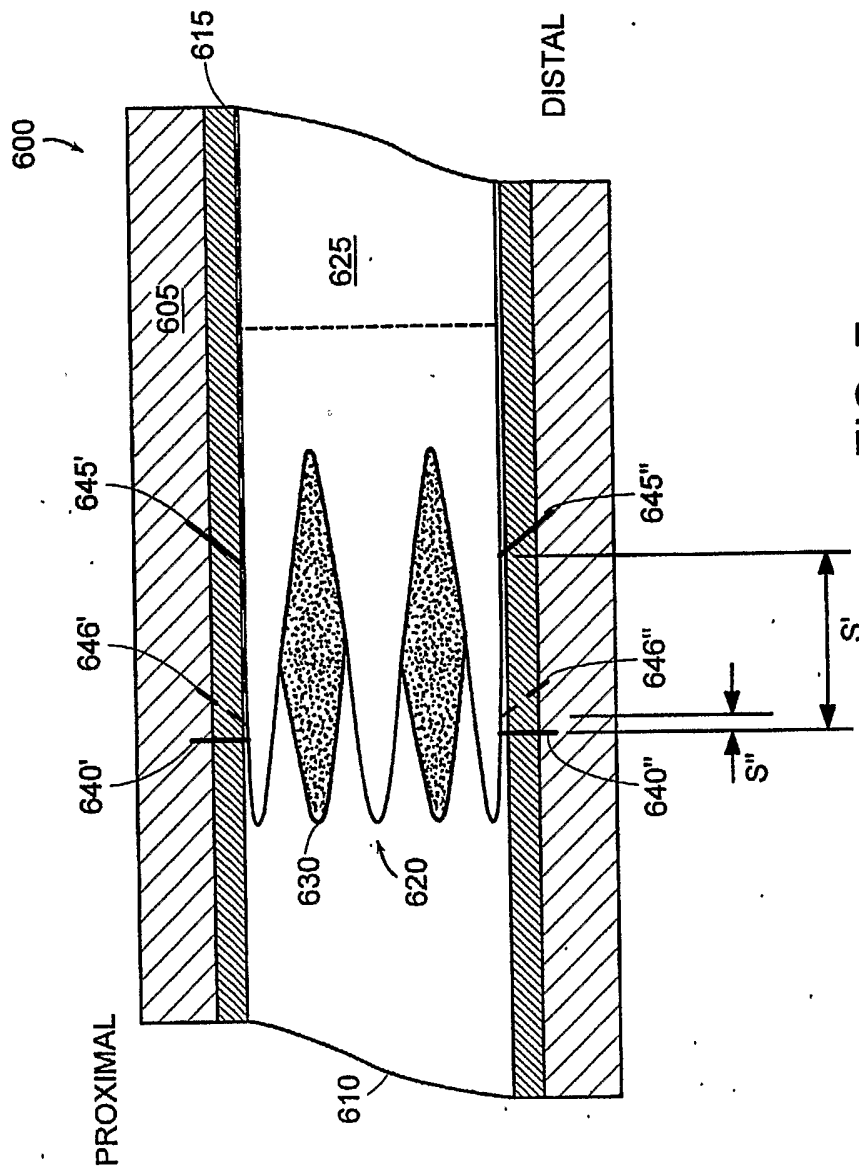

FIG. 7

8/21

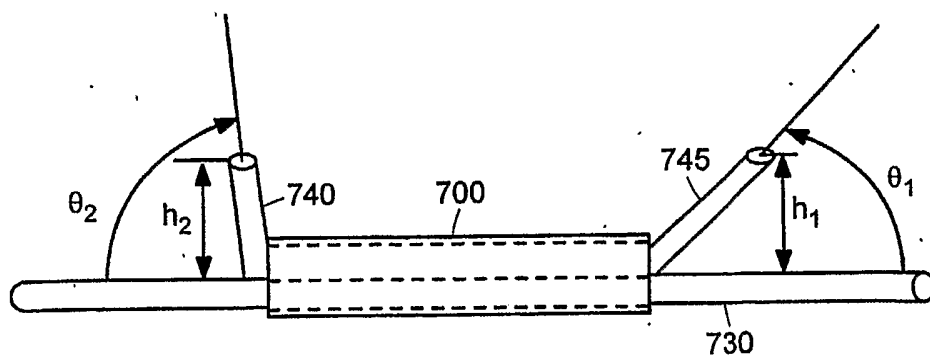

FIG. 8A

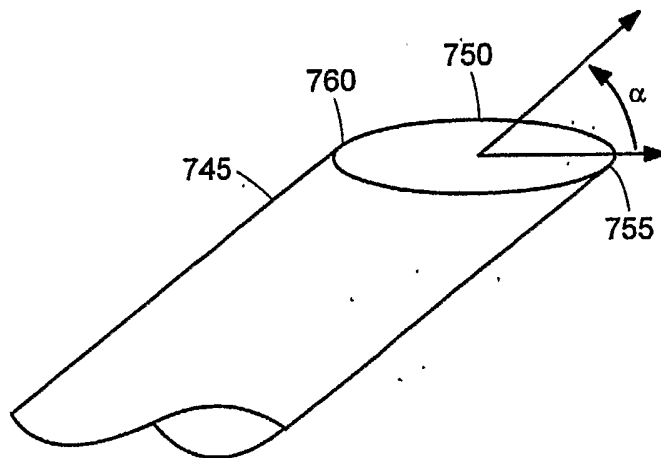

FIG. 8B

9/21

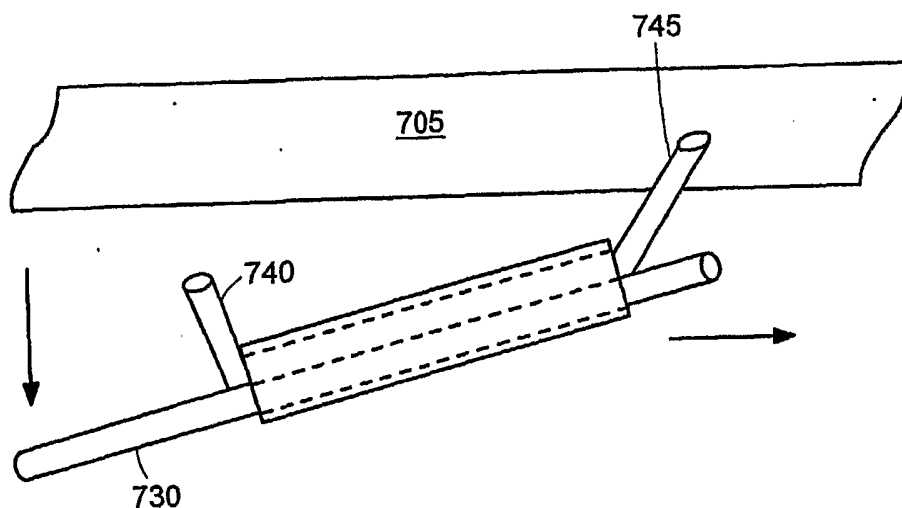

FIG. 8C

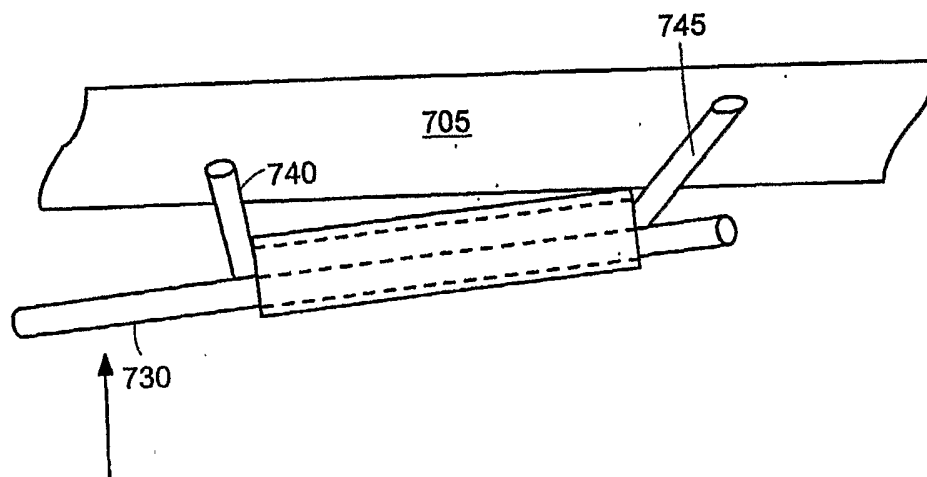

FIG. 8D

10/21

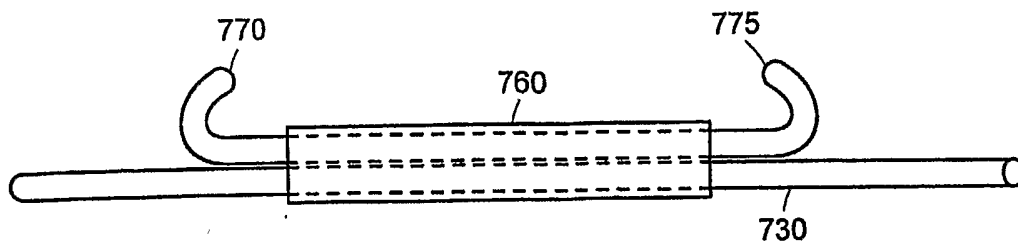

FIG. 8E

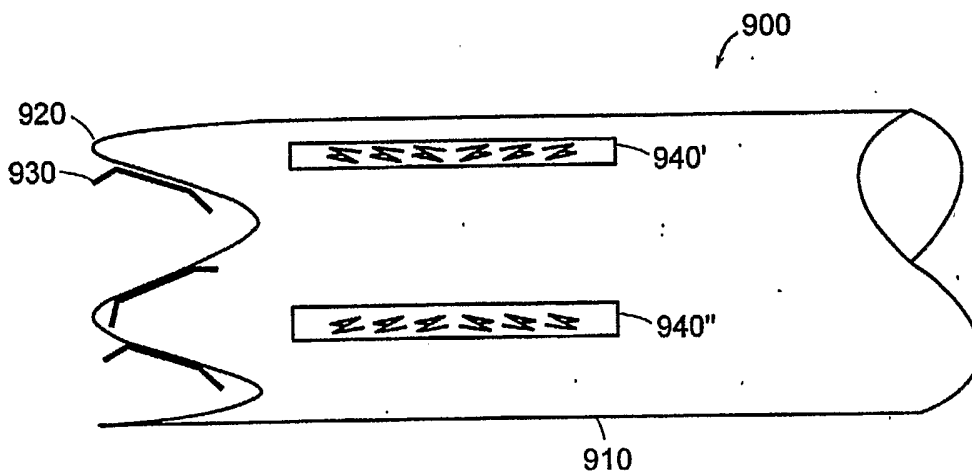

FIG. 9

11/21

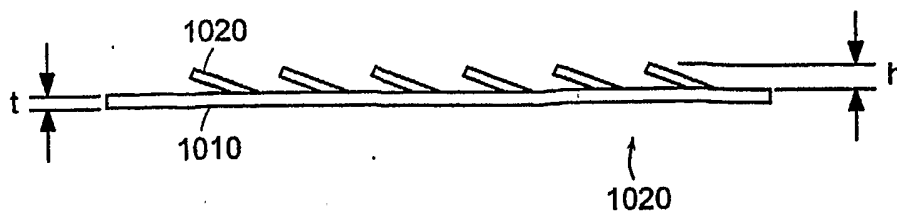

FIG. 10A

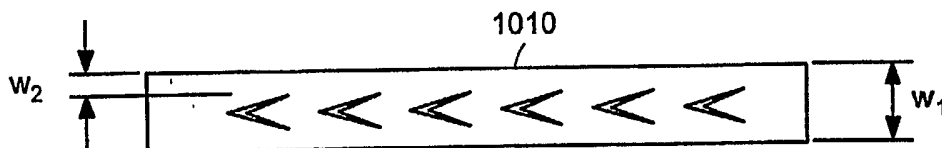

FIG. 10B

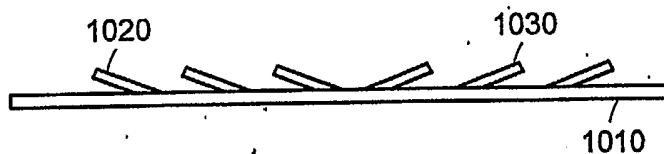

FIG. 11A

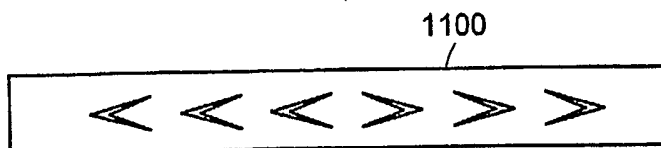

FIG. 11B

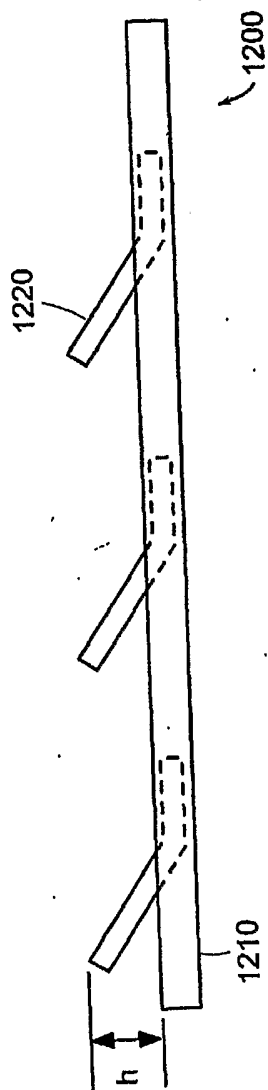

FIG. 12A

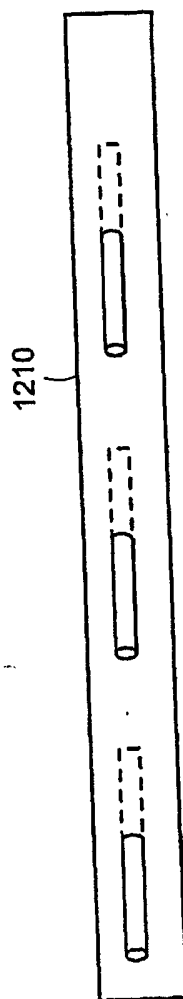

FIG. 12B

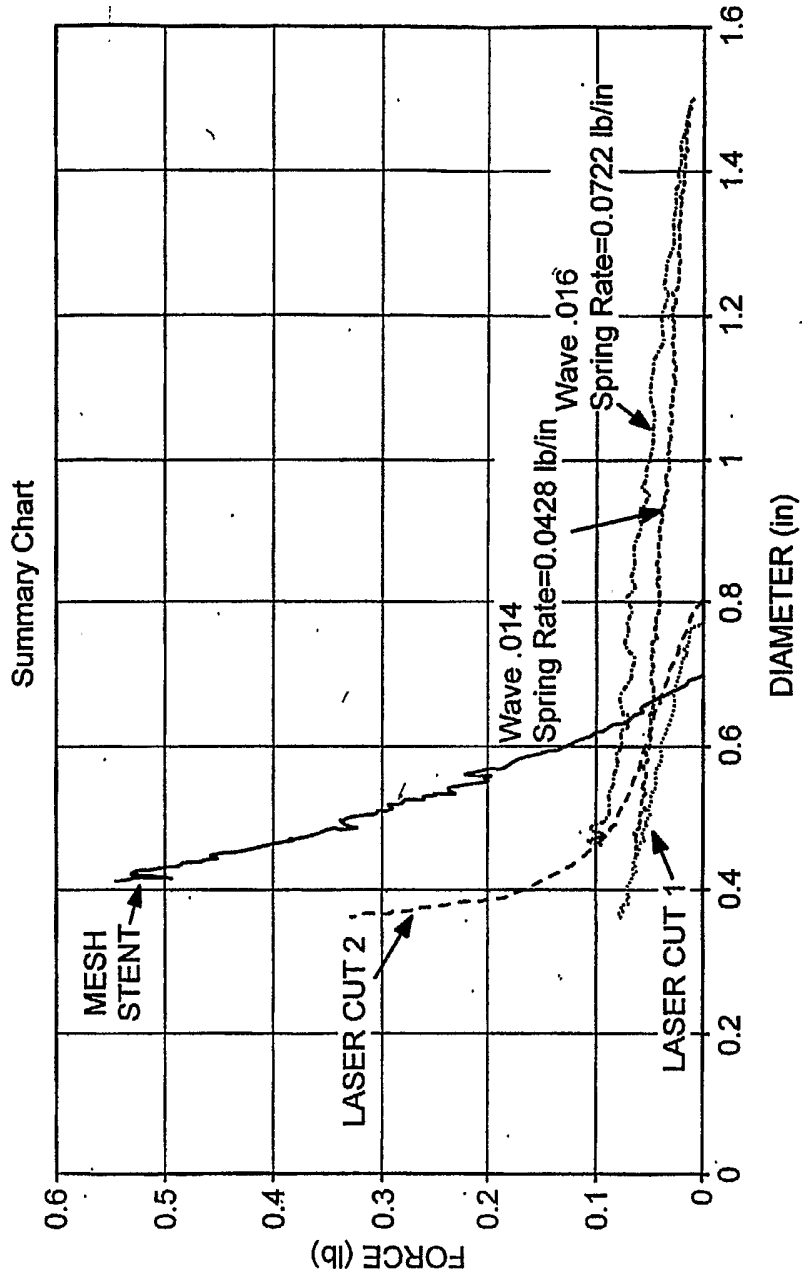

FIG. 13

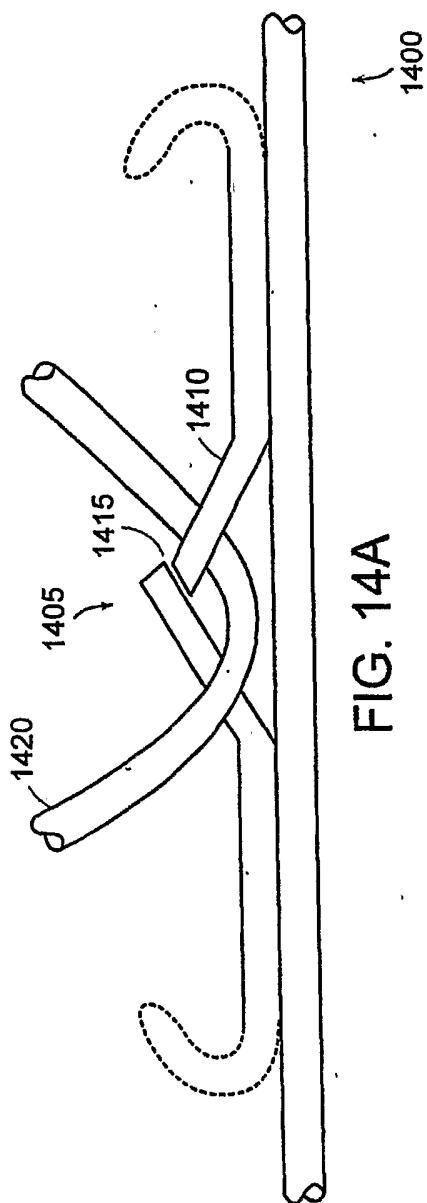

FIG. 14A

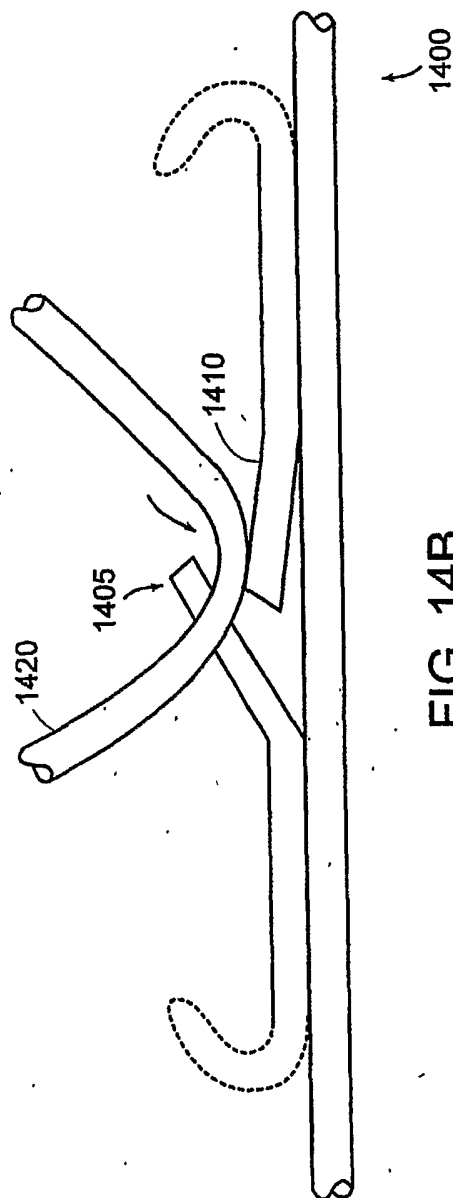

FIG. 14B

15/21

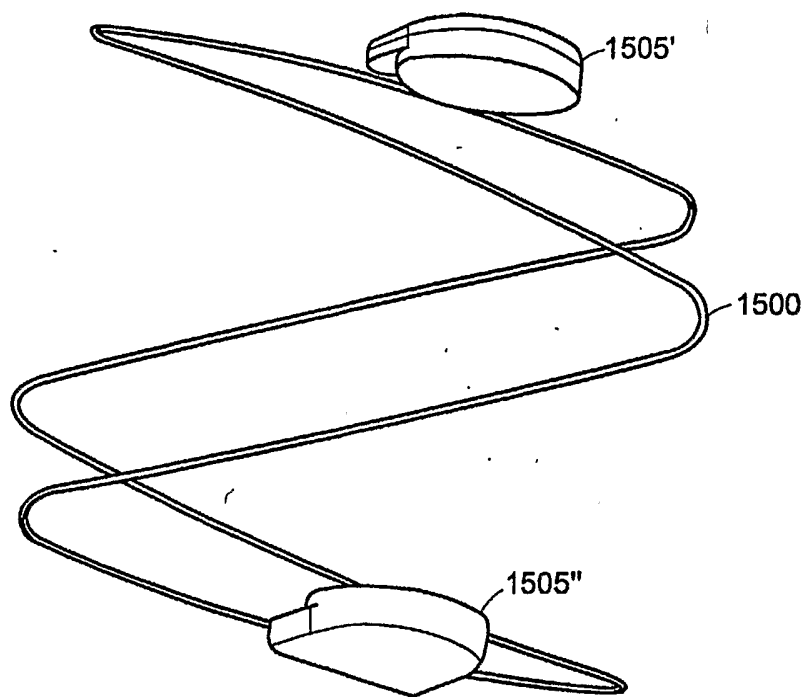

FIG. 15A

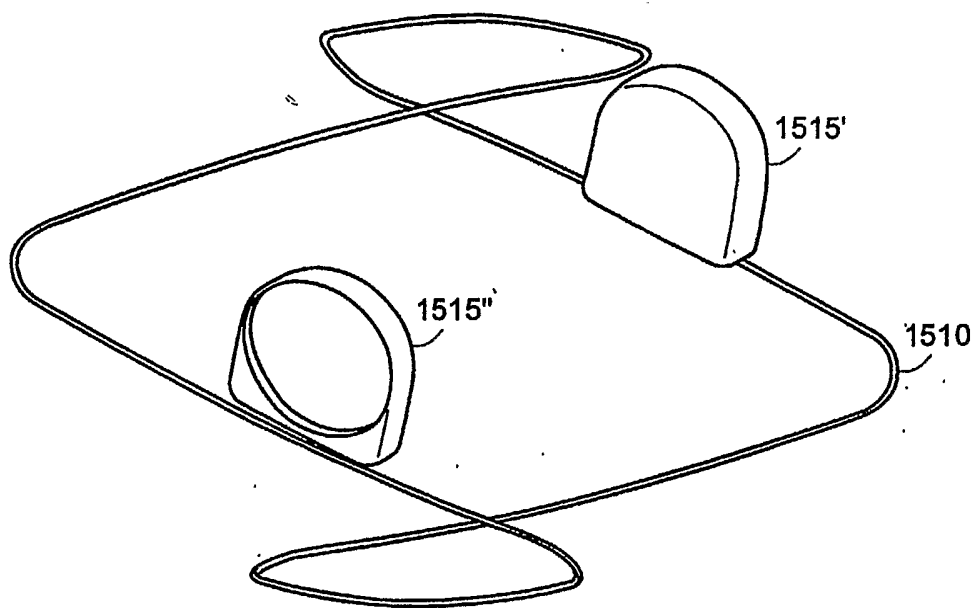

FIG. 15B

17/21

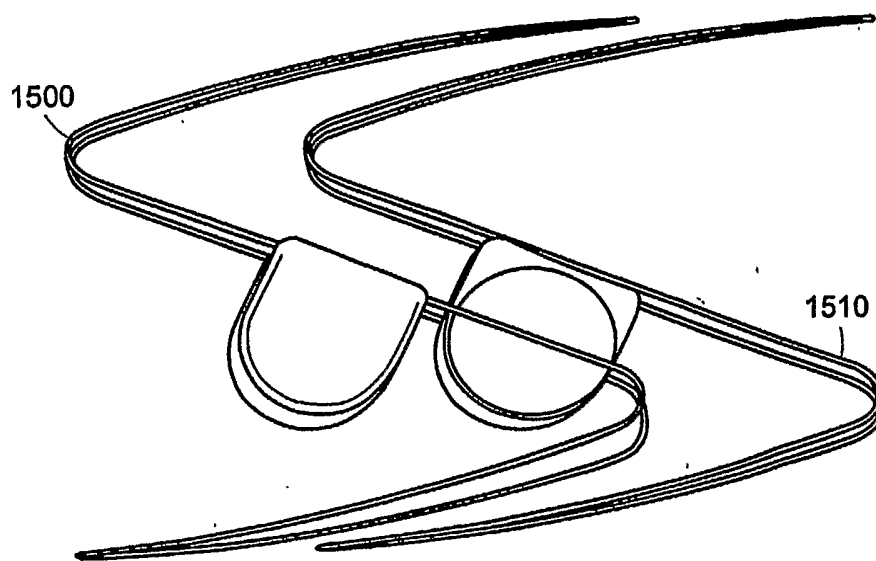

FIG. 15C

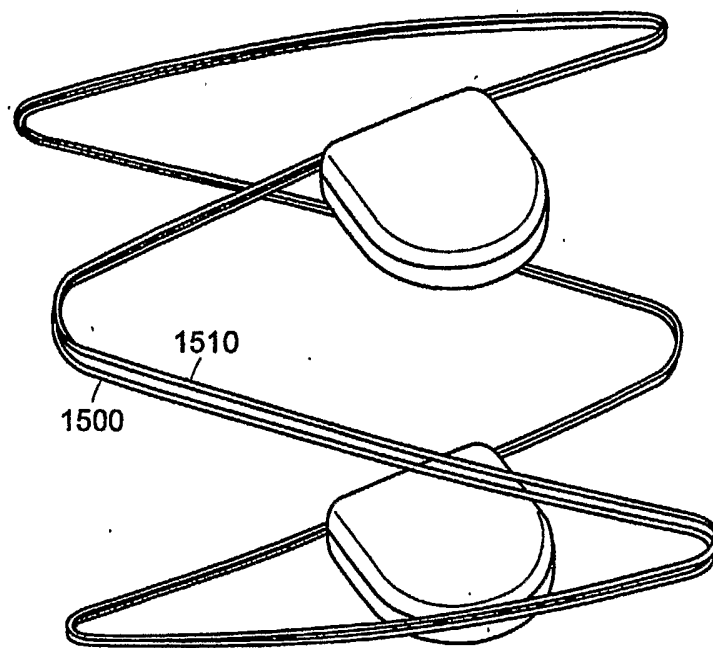

FIG. 15D

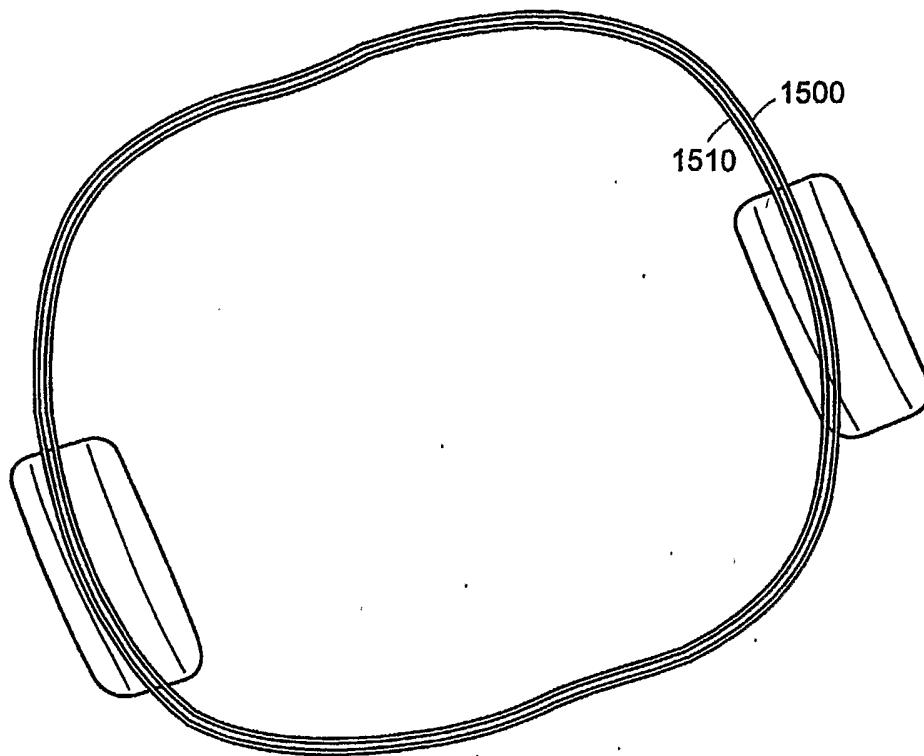

FIG. 15E

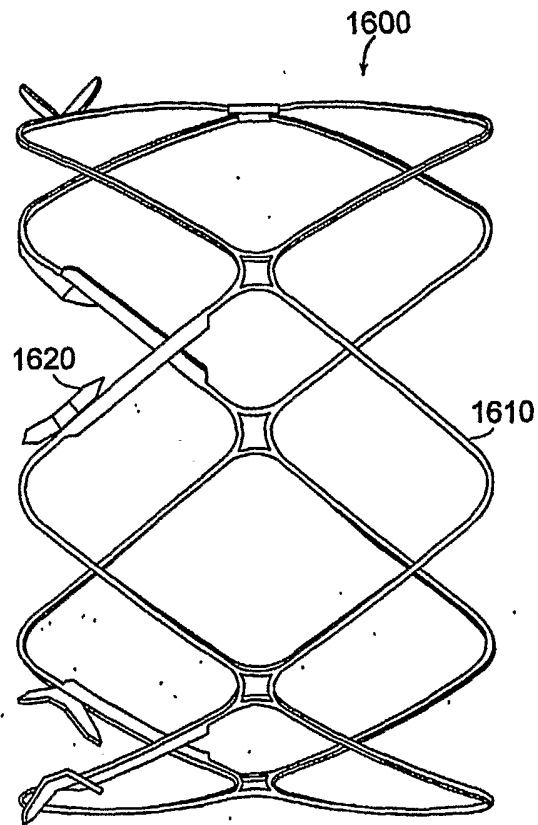

FIG. 16

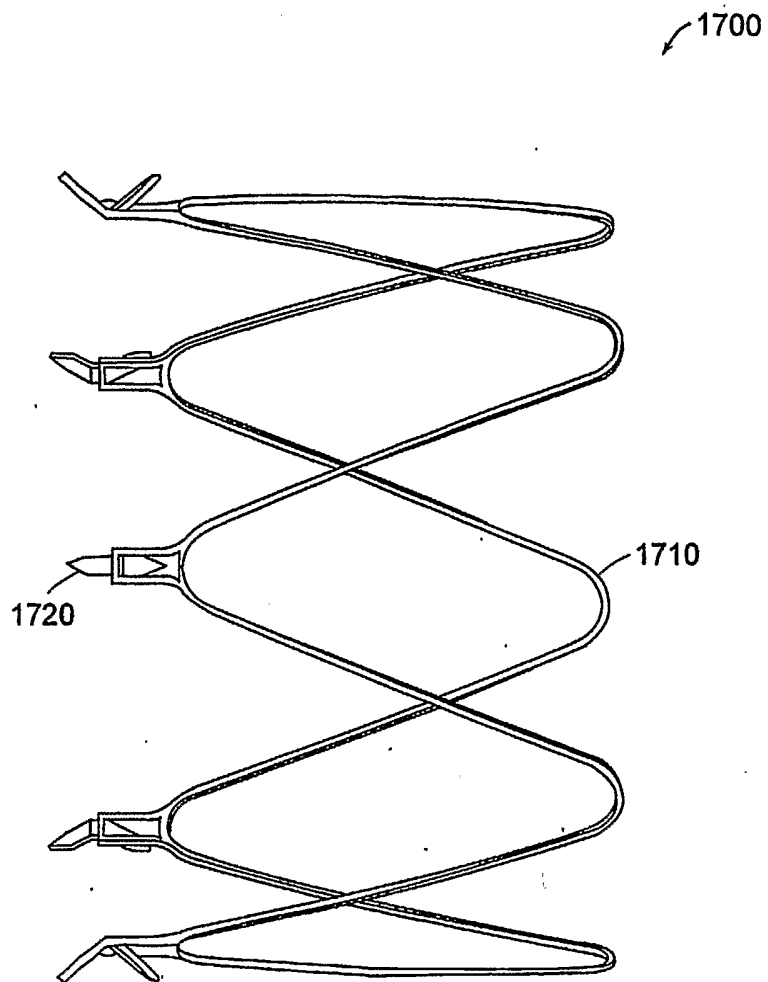

FIG. 17

INTERNATIONAL SEARCH REPORT

International Application No
PCT/US2004/017591

A. CLASSIFICATION OF SUBJECT MATTER
IPC 7 A61F5/00 A61F2/06

According to International Patent Classification (IPC) or to both national classification and IPC

B. FIELDS SEARCHED

Minimum documentation searched (classification system followed by classification symbols)
IPC 7 A61F

Documentation searched other than minimum documentation to the extent that such documents are included in the fields searched

Electronic data base consulted during the international search (name of data base and, where practical, search terms used)

EPO-Internal

C. DOCUMENTS CONSIDERED TO BE RELEVANT

Category °	Citation of document, with indication, where appropriate, of the relevant passages	Relevant to claim No.
Y	WO 03/094785 A (EGAN THOMAS D) 20 November 2003 (2003-11-20) page 13, line 29 - line 31 figure 2	1,6-11
Y A	----- US 6 302 917 B1 (MOORE SCOTT T ET AL) 16 October 2001 (2001-10-16) column 3, line 1 - line 3 column 3, line 42 - line 46 figures 1,5	1,6-11 2,5,6, 17,20,57
A	----- US 2003/109931 A1 (GEITZ KURT) 12 June 2003 (2003-06-12) paragraph [0010] - paragraph [0013] figures 1,2 ----- -/--	1-4

Further documents are listed in the continuation of box C.

Patent family members are listed in annex.

° Special categories of cited documents :

"A" document defining the general state of the art which is not considered to be of particular relevance

"E" earlier document but published on or after the international filing date

"L" document which may throw doubts on priority claim(s) or which is cited to establish the publication date of another citation or other special reason (as specified)

"O" document referring to an oral disclosure, use, exhibition or other means

"P" document published prior to the international filing date but later than the priority date claimed

"T" later document published after the international filing date or priority date and not in conflict with the application but cited to understand the principle or theory underlying the invention

"X" document of particular relevance; the claimed invention cannot be considered novel or cannot be considered to involve an inventive step when the document is taken alone

"Y" document of particular relevance; the claimed invention cannot be considered to involve an inventive step when the document is combined with one or more other such documents, such combination being obvious to a person skilled in the art.

"&" document member of the same patent family

Date of the actual completion of the international search

3 November 2004

Date of mailing of the international search report

23. 03. 2005

Name and mailing address of the ISA

European Patent Office, P.B. 5818 Patentlaan 2
NL - 2280 HV Rijswijk
Tel. (+31-70) 340-2040, Tx. 31 651 epo nl,
Fax: (+31-70) 340-3016

Authorized officer

Amaro, H

INTERNATIONAL SEARCH REPORT

International Application No
PCT/US2004/017591

C.(Continuation) DOCUMENTS CONSIDERED TO BE RELEVANT		
Category *	Citation of document, with indication, where appropriate, of the relevant passages	Relevant to claim No.
A	US 5 720 776 A (CHUTER TIMOTHY A ET AL) 24 February 1998 (1998-02-24) column 11, line 53 - column 12, line 6 figures 2-5 -----	19-21, 23-28
A	US 6 035 856 A (EUTENEUER CHARLES L ET AL) 14 March 2000 (2000-03-14) column 8, line 23 - line 26 figure 7 -----	21,22
A	US 2002/188344 A1 (POLYAK MARK ET AL) 12 December 2002 (2002-12-12) paragraph [0010] figures 1-5B -----	5

INTERNATIONAL SEARCH REPORT

International application No.
PCT/US2004/017591

Box II Observations where certain claims were found unsearchable (Continuation of item 2 of first sheet)

This International Search Report has not been established in respect of certain claims under Article 17(2)(a) for the following reasons:

1. Claims Nos.: 29-56, 65-71
because they relate to subject matter not required to be searched by this Authority, namely:
Rule 39.1(iv) PCT - Method for treatment of the human or animal body by therapy
2. Claims Nos.:
because they relate to parts of the International Application that do not comply with the prescribed requirements to such an extent that no meaningful International Search can be carried out, specifically:
3. Claims Nos.:
because they are dependent claims and are not drafted in accordance with the second and third sentences of Rule 6.4(a).

Box III Observations where unity of invention is lacking (Continuation of item 3 of first sheet)

This International Searching Authority found multiple inventions in this international application, as follows:

see additional sheet

1. As all required additional search fees were timely paid by the applicant, this International Search Report covers all searchable claims.
2. As all searchable claims could be searched without effort justifying an additional fee, this Authority did not invite payment of any additional fee.
3. As only some of the required additional search fees were timely paid by the applicant, this International Search Report covers only those claims for which fees were paid, specifically claims Nos.:
4. No required additional search fees were timely paid by the applicant. Consequently, this International Search Report is restricted to the invention first mentioned in the claims; it is covered by claims Nos.:
1-28

Remark on Protest

- The additional search fees were accompanied by the applicant's protest.
- No protest accompanied the payment of additional search fees.

FURTHER INFORMATION CONTINUED FROM PCT/ISA/ 210

This International Searching Authority found multiple (groups of) inventions in this international application, as follows:

1. claims: 1-28

A gastrointestinal implant device comprising an unsupported flexible sleeve adapted to extend into the intestine and wave anchor coupled thereto.

2. claims: 57-64

A gastrointestinal implant device comprising a gastrointestinal implant, a first annular element provided with a fastener for fixedly securing it to a natural lumen and a connector for removably coupling the gastrointestinal implant and the first annular element.

INTERNATIONAL SEARCH REPORT

Information on patent family members

International Application No

PCT/US2004/017591

Patent document cited in search report		Publication date	Patent family member(s)	Publication date
WO 03094785	A	20-11-2003	AU 2003249628 A1	11-11-2003
			CA 2485249 A1	20-11-2003
			WO 03094785 A1	20-11-2003

US 6302917	B1	16-10-2001	US 2003060894 A1	27-03-2003
			US 2004199262 A1	07-10-2004
			US 2002032487 A1	14-03-2002
			AT 254889 T	15-12-2003
			AU 747060 B2	09-05-2002
			AU 5790699 A	19-06-2000
			CA 2338518 A1	08-06-2000
			DE 69913163 D1	08-01-2004
			DE 69913163 T2	09-09-2004
			DK 1109511 T3	15-03-2004
			EP 1109511 A1	27-06-2001
			ES 2212623 T3	16-07-2004
			JP 2002531169 T	24-09-2002
			PT 1109511 T	31-03-2004
			WO 0032137 A1	08-06-2000

US 2003109931	A1	12-06-2003	US 2004204768 A1	14-10-2004

US 5720776	A	24-02-1998	US 5693084 A	02-12-1997
			US 5387235 A	07-02-1995
			AT 287675 T	15-02-2005
			AU 703150 B2	18-03-1999
			AU 5478096 A	19-12-1996
			CA 2172647 A1	08-12-1996
			DE 69634225 D1	03-03-2005
			EP 0747020 A2	11-12-1996
			JP 9098974 A	15-04-1997
			AU 687304 B2	19-02-1998
			AU 4972296 A	27-08-1996
			CA 2212286 A1	15-08-1996
			DE 69617912 D1	24-01-2002
			DE 69617912 T2	04-07-2002
			DK 808140 T3	25-02-2002
			EP 0808140 A1	26-11-1997
			ES 2169792 T3	16-07-2002
			JP 10513383 T	22-12-1998
			WO 9624308 A1	15-08-1996
			AU 669338 B2	06-06-1996
			AU 5139499 A	23-12-1999
			CA 2081424 A1	26-04-1993
			EP 0539237 A1	28-04-1993
			JP 3324707 B2	17-09-2002
			JP 5305092 A	19-11-1993
			AU 2735392 A	13-05-1993
			US 5562726 A	08-10-1996
			US 5755777 A	26-05-1998
			US 5456713 A	10-10-1995

US 6035856	A	14-03-2000	US 2002092536 A1	18-07-2002
			WO 9838939 A1	11-09-1998
			US 6390098 B1	21-05-2002

US 2002188344	A1	12-12-2002	NONE	
