



⑫ **EUROPEAN PATENT APPLICATION**

⑲ Application number : **91301733.1**

⑤① Int. Cl.⁵ : **F41G 3/02, F42B 12/36**

⑳ Date of filing : **11.03.91**

③① Priority : **10.03.90 GB 9005457**

⑦② Inventor : **Rutt, Harvey Nicholas**
22 Galleyfield
Abingdon, Oxfordshire OX14 3RT (GB)

④③ Date of publication of application :
18.09.91 Bulletin 91/38

⑦④ Representative : **Wood, Paul Austin et al**
United Kingdom Atomic Energy Authority
Patents Branch B329 Harwell Laboratory
Oxfordshire OX11 0RA (GB)

⑧④ Designated Contracting States :
BE DE ES FR IT SE

⑦① Applicant : **UNITED KINGDOM ATOMIC**
ENERGY AUTHORITY
11 Charles II Street
London SW1Y 4QP (GB)

⑤④ **Reconnaissance device.**

⑤⑦ A reconnaissance device (1) comprising, an elongated body (3) having a flight-arresting device at one end, an image-forming device (7) at the other and a telemetry package (9) in the central part of the body of the device. Preferably the device is interchangeable with a standard mortar bomb.

EP 0 447 080 A1

Fig. 1.

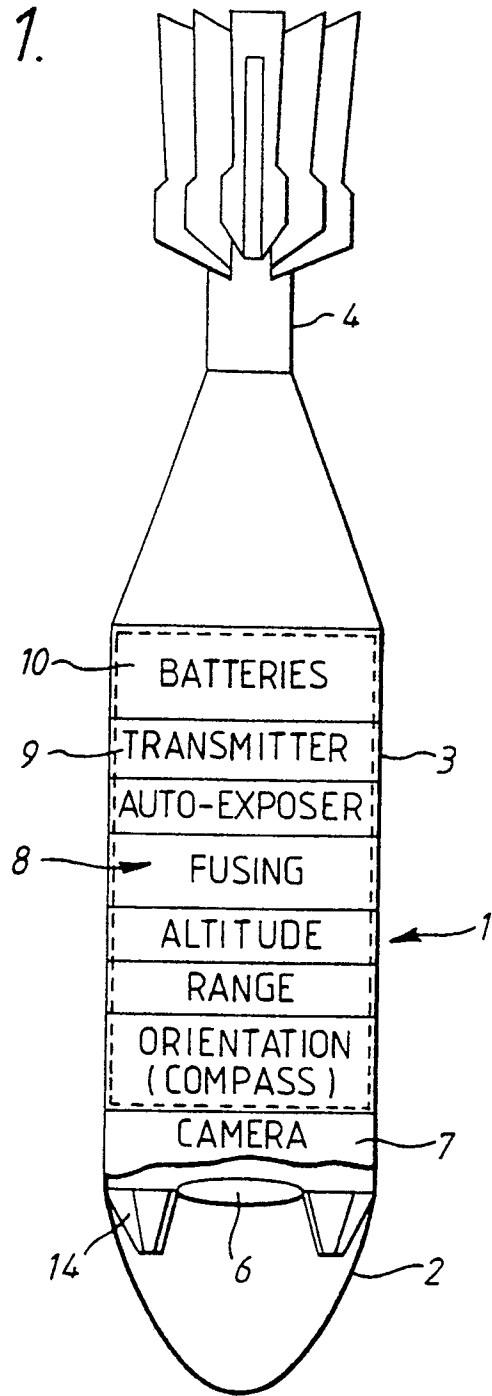

RECONNAISSANCE DEVICE

The present invention relates to a device for tactical reconnaissance and survey.

Existing methods of tactical reconnaissance and survey involve the use of aircraft, manned or remotely controlled, or mobile reconnaissance units, traditionally light cavalry. Both these methods have disadvantages in that very heavy equipment use is involved and they often cannot respond either quickly enough, or on a sufficiently localised scale, particularly in the case where the military situation is very fluid.

There is, therefore a need for a highly mobile, inexpensive, preferably expendable, reconnaissance device which is capable of being used by ground troops when in, or about to become in contact with an adversary.

An aerial reconnaissance device comprising an elongated body having a flight-arresting device at one end, an image-forming device at the other end, a telemetry package adapted to transmit to a receiving station an image of a scene viewed by the image-forming device and means for deploying the flight-arresting device at a suitable point in the flight path of the reconnaissance device when it is in use.

The image-forming device preferably is a solid-state television camera which may be adapted to operate in the visual or infra-red regions of the electromagnetic spectrum.

The telemetry package in addition to being adapted to transmit to a receiving station an image of the scene viewed by the image-forming device, may be adapted also to measure air temperature, wind speed and direction, barometric pressure, and the range of objects in the field of view of the image-forming device.

Preferably the device is in the form of a projectile, most suitably, such that it can be launched from a conventional mortar, although other forms of projectile, or even free-falling devices which can be launched from aircraft, are envisaged.

It is particularly advantageous for the device to be in the form of a mortar bomb of conventional form so that it may be interchangeable with standard rounds of mortar ammunition. Such weapons are simple, highly mobile and used by troops in immediate contact with their adversaries. Also, mortars are high-angle, low velocity, weapons which would give the reconnaissance devices relatively high apogees without subjecting them to excessively large initial accelerations.

The invention will now be described, by way of example, with reference to the accompanying drawings, in which

Figure 1 is a representation of an embodiment of the invention in the form of a mortar bomb, and

Figure 2 shows the embodiment of Figure 1 in use.

Referring to the drawings, a reconnaissance device embodying the invention consists of a casing 1 the overall shape and size of which is such that the reconnaissance device is interchangeable with a round of conventional mortar ammunition. The casing 1 is in three portions, a nose cone 2, a central main body 3 and a tail assembly 4. The complete assembly is adapted to be launched from a trench mortar in the usual way. Both the nose cone 2 and the tail assembly 4 are arranged to be separated from the main body 3 of the casing 1 at an appropriate moment in the flight of the reconnaissance device. The main body 3 of the casing 1 contains a fuse or other control device arranged to jettison the nose cone 2 and tail assembly 4 when desired; an optical system 6, shown schematically as a lens, and an associated solid-state video camera 7. Also contained in the main body 3 of the casing 1 is a telemetry package 8 which includes transponders arranged to provide information as to the range of the device from its launching point, its altitude and possibly its orientation, a radio transmitter 9 and power pack 10. An antenna for the transmitter 9 is incorporated in the cords 11 and canopy 12 of a parachute 13 which is contained in the tail assembly 4 and deployed when the tail assembly 4 is jettisoned, as shown in Figure 2. The optical system 6 is surrounded by a shock-absorbent buffer 14.

The optical system 6, camera 7 and telemetry package 8 are all protected against shock, both to enable them to withstand the launch forces and to enable the main body 3 of the reconnaissance device to be recovered and re-used. This is particularly important if it is used in a training role.

Signals from the transmitter 9 are received at a man-portable command unit 15. The command unit 15 is arranged to produce and display an image of the scene observed by the optical system 6 and its associated camera 7, together with range and bearing information derived from the output of the telemetry package 8. A micro-computer contained in the command unit 15 is arranged to compute correction factors to enable the fall of observed live mortar rounds to be ranged onto selected targets. Wind drift may be derived either by telemetry from the reconnaissance device or by measuring the drift of objects in the displayed image of the scene observed by the reconnaissance device. The command unit 15 may contain also a pattern-recognition facility to assist in target recognition.

The command module 15 may include also a short duration recorder to enable scenes observed by the reconnaissance device to be reviewed if desired. Also, signals from the telemetry package 8 related to

the orientation of the reconnaissance device, particularly if it is being deliberately spun, may be used in the command module 15 to produce a steady image of constant orientation. Also the computer in the command module 15 may be programmed to produce an image on the display of constant size as the height of the reconnaissance device decreases, which may be to the same scale as standard military maps and/or include a scale bar.

The reconnaissance device may be stabilised against spinning by means of subsidiary drogues, or by winglets which are deployed at the same time as the parachute 13. Alternatively, the optical system 6 may be mounted with its optic axis at an angle to the longitudinal axis of the reconnaissance device and the reconnaissance device made deliberately to rotate so as to enable a larger area to be viewed. The same effect could be achieved with a stabilised reconnaissance device by incorporating a scanning mirror in the optical system 6. Other optional features which could be included in the optical system 6, are interchangeable lenses of differing focal lengths or a zoom lens operated by signals from the command unit 15. The telemetry package 8 also may include detectors arranged to pick up and relay to the command unit 14 radio signals and/or vehicle ignition emissions.

A modified form of the device which can be used for covert reconnaissance does not deploy a parachute or a balloon but uses air brakes which form part of the casing 1 of the reconnaissance device.

Claims

1. An aerial reconnaissance device comprising an elongated body having a flight-arresting device at one end, an image-forming device at the other end, a telemetry package adapted to transmit to a receiving station an image of a scene viewed by the image-forming device and means for deploying the flight-arresting device at a suitable point in the flight path of the reconnaissance device when it is in use. 35 40
2. A reconnaissance device according to claim 1 wherein the flight-arresting device is a parachute or balloon. 45
3. A reconnaissance device according to claim 1 or claim 2 wherein the image-forming device is a solid-state television camera. 50
4. A reconnaissance device according to any preceding claim wherein the telemetry package is adapted to measure and transmit information relating to air temperature, wind speed and direction, barometric pressure and the range of objects in the field of view of the image-forming device. 55
5. A reconnaissance device according to any preceding claim wherein the device is adapted to be launched as a projectile.
6. A reconnaissance device according to claim 5 wherein the device is adapted to be fired from a mortar. 5
7. A reconnaissance device according to claim 6 wherein the reconnaissance device is adapted to be interchangeable with standard mortar ammunition. 10
8. An aerial reconnaissance device according to any preceding claim in association with a receiving station wherein the receiving station is adapted to display an image of the scene observed by the reconnaissance device and other parameters transmitted by the telemetry package. 15 20
9. An aerial reconnaissance device according to claim 8 wherein the receiving station includes means for recording the image of the scene observed by the image-forming device and the other parameters transmitted by the telemetry package. 25 30

Fig. 1.

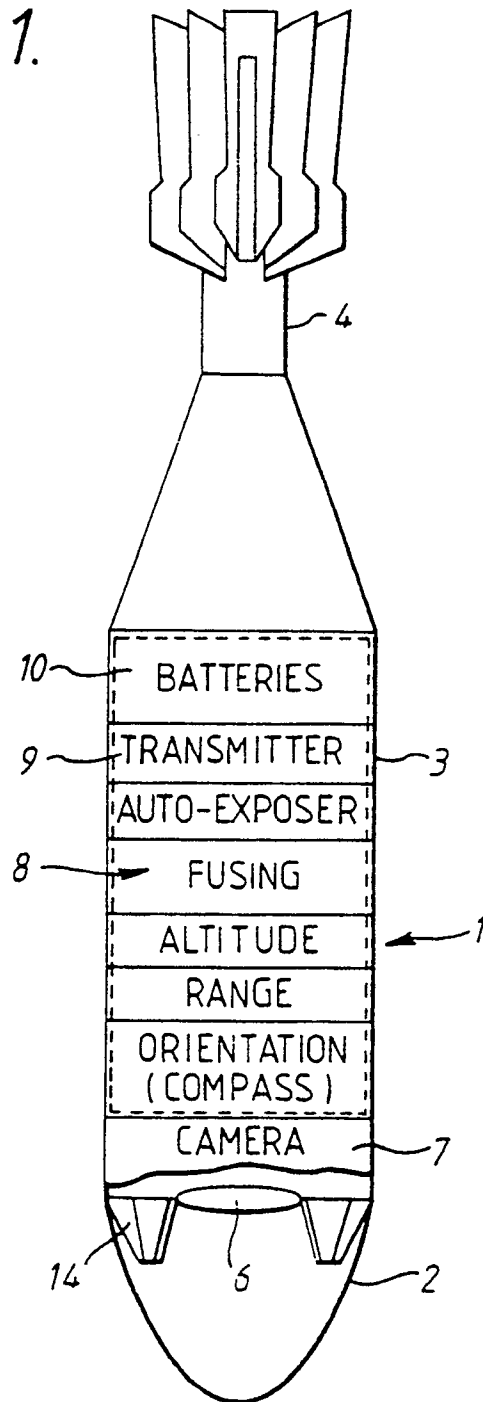
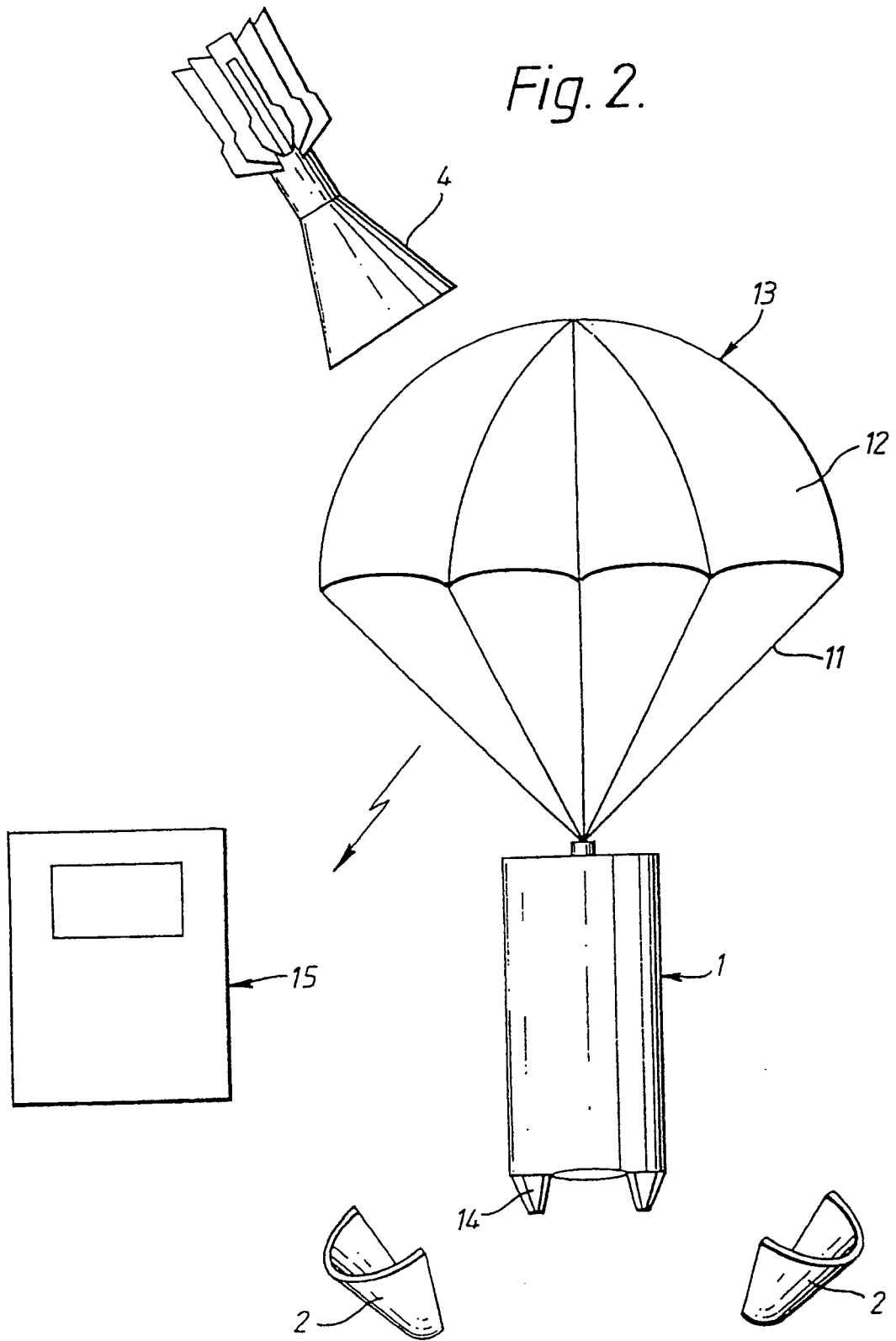

Fig. 2.





European Patent
Office

EUROPEAN SEARCH REPORT

Application Number

EP 91 30 1733

DOCUMENTS CONSIDERED TO BE RELEVANT			
Category	Citation of document with indication, where appropriate, of relevant passages	Relevant to claim	CLASSIFICATION OF THE APPLICATION (Int. Cl.5)
X	US-A-4 267 562 (RAIMONDI) * Abstract; column 2, lines 17-43; column 3, lines 26-35; column 8, lines 17-50; column 11, lines 20-29,51-63; figures 2,3,5 *	1,2,5-9	F 41 F 3/02 F 42 B 12/36
Y	---	3,4	
X	US-A-3 962 537 (KEARNS et al.) * Abstract; column 1, line 5 - column 4, line 13; figures 1-3 *	1-3,5-9	
Y	---	4	
Y	US-A-4 481 514 (BEUKERS et al.) * Abstract; column 1, lines 4-48; figure 1 *	1-9	
X	FR-A-2 541 444 (TH-CSF) * Abstract; page 2, line 16 - page 3, line 3; page 3, lines 22-34; page 7, lines 5-12; page 8, lines 10-17; page 9, lines 5-24; page 12, lines 3-15; page 13, line 31 - page 15, line 11; figures 2,3,7 *	1-3,5-7	
Y	---	4,8,9	
Y	US-A-4 112 753 (CALL) * Abstrat; column 1, lines 5-20; column 3, line 50 - column 4, line 29; column 6, lines 43-58; figures 2,3,13 *	1-9	F 41 G F 42 B B 64 B B 64 D G 01 W
X	PATENT ABSTRACTS OF JAPAN, vol. 12, nr. 435 (E-683),13th July 1988; & JP-A-63 169 200 (SASAKI TATSURO) 06-01-1987 * Whole abstract with its drawing * --- -/-	1,2,8,9	
The present search report has been drawn up for all claims			
Place of search THE HAGUE		Date of completion of the search 17-05-1991	Examiner BLONDEL F.J.M.L.J.
CATEGORY OF CITED DOCUMENTS X : particularly relevant if taken alone Y : particularly relevant if combined with another document of the same category A : technological background O : non-written disclosure P : intermediate document		I : theory or principle underlying the invention E : earlier patent document, but published on, or after the filing date D : document cited in the application L : document cited for other reasons & : member of the same patent family, corresponding document	

EPO FORM 1503 03.82 (P0401)



European Patent
Office

EUROPEAN SEARCH REPORT

Application Number

EP 91 30 1733

DOCUMENTS CONSIDERED TO BE RELEVANT			
Category	Citation of document with indication, where appropriate, of relevant passages	Relevant to claim	CLASSIFICATION OF THE APPLICATION (Int. Cl.5)
Y	IDEM ---	3-7	
X	GB-A-1 284 487 (MULLARD LTD) * Page 1, left hand column, line 9 - page 3, left hand column, line 17; figures 1-4 * -----	1,5-7	
			TECHNICAL FIELDS SEARCHED (Int. Cl.5)
The present search report has been drawn up for all claims			
Place of search THE HAGUE		Date of completion of the search 17-05-1991	Examiner BLONDEL F.J.M.L.J.
CATEGORY OF CITED DOCUMENTS X : particularly relevant if taken alone Y : particularly relevant if combined with another document of the same category A : technological background O : non-written disclosure P : intermediate document		T : theory or principle underlying the invention E : earlier patent document, but published on, or after the filing date D : document cited in the application L : document cited for other reasons ----- & : member of the same patent family, corresponding document	

EPO FORM 1503 03.92 (P0601)