

(No Model.)

J. J. HURLEY.

ANTIFRICTION BEARING FOR LATHE SPINDLES.

No. 560,001.

Patented May 12, 1896.

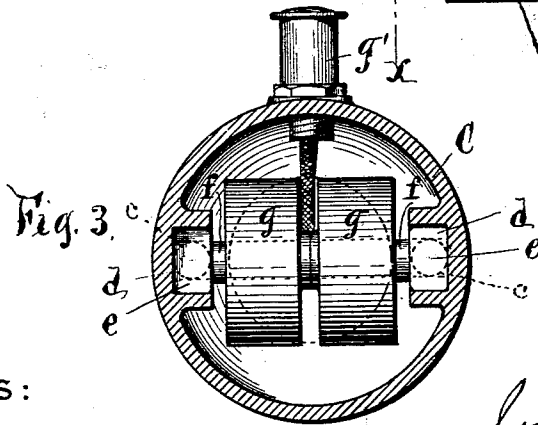
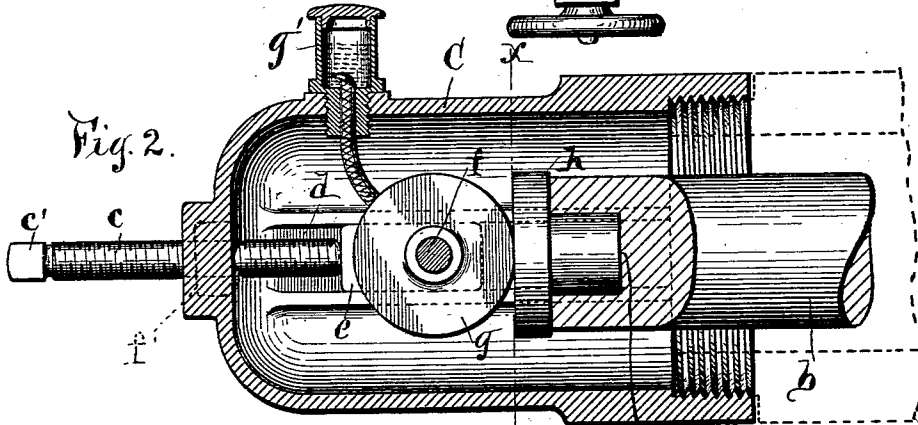
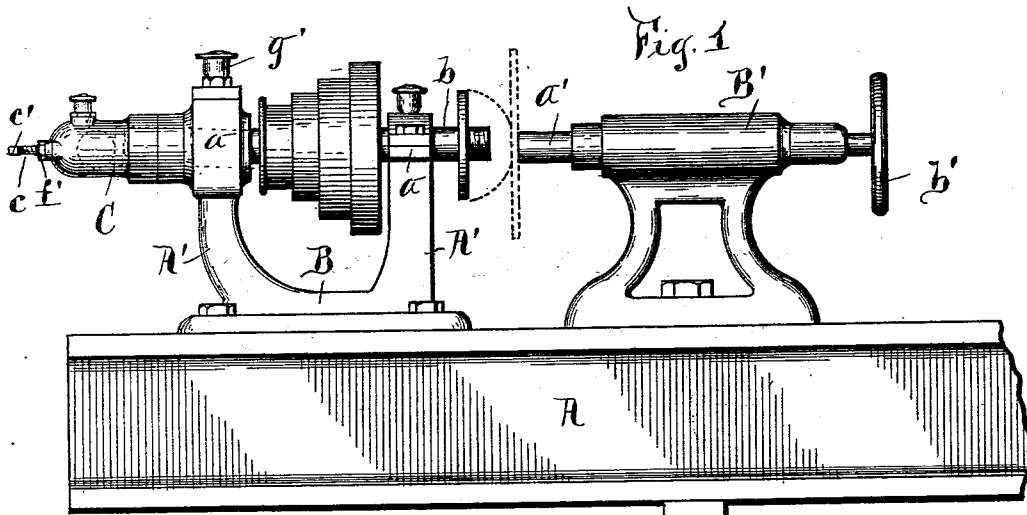

WITNESSES:

W. Robinson.
J. J. Laas.

INVENTOR

John J. Hurley
By *E. Laas*
his ATTORNEY

UNITED STATES PATENT OFFICE.

JOHN J. HURLEY, OF EAST SYRACUSE, NEW YORK, ASSIGNOR OF ONE-HALF
TO EMIL MAGNUS, OF SYRACUSE, NEW YORK.

ANTIFRICTION-BEARING FOR LATHE-SPINDLES.

SPECIFICATION forming part of Letters Patent No. 560,001, dated May 12, 1896.

Application filed September 4, 1895. Serial No. 561,438. (No model.)

To all whom it may concern:

Be it known that I, JOHN J. HURLEY, of East Syracuse, in the county of Onondaga, in the State of New York, have invented new and useful Improvements in Antifriiction-Bearings for Lathe-Spindles, of which the following, taken in connection with the accompanying drawings, is a full, clear, and exact description.

This invention is specially designed for metal-spinning lathes and analogous lathes in which the live-spindle is subjected to pressure endwise thereof.

The object of the invention is to provide more efficient and more readily adjustable means for relieving the said spindle from friction and abrasion on the end thereof, and thus preserve the said spindle; and to that end the invention consists in the improved construction and combination of parts, as hereinafter more fully described, and specifically set forth in the claim.

In the annexed drawings, Figure 1 is a front elevation of a metal-spinning lathe embodying my improvements. Fig. 2 is an enlarged longitudinal section of the casing in which the aforesaid rollers are located; and Fig. 3 is a transverse section on line X X, Fig. 2.

Referring to the drawings, A represents the lathe-frame, on which is mounted the head-stock B, formed of two vertical arms A' A', provided with suitable journal-bearings a a, in which is mounted the horizontal live-spindle b. On the rear arm A' is secured the casing C, formed with two longitudinal guides d d, in which guides are located two longitudinally-shifting blocks e e. Diametrically across said casing extends a shaft f, which is secured to said block and has mounted on it two independently-revoluble rollers g g, which bear with their peripheries against the end of the spindle b on opposite sides of the center thereof, and thus sustain said spindle against end thrust incident to the pressure of the shaping-tool in the operation of spinning the metal held on the end of the live-spindle, as indicated by dotted lines in Fig. 1 of the drawings.

The dead-spindle a' is screw-threaded and

works in a screw-threaded bearing on the head-stock B', and is provided with a hand-wheel b', by which to turn said spindle, so as to set it up to and hold the metal to be operated on.

The rear end of the casing C is provided with screw-threaded eyes, through which pass set-screws c c, which are parallel to the axis of the spindle and bear with their inner ends against the rear of the aforesaid blocks e e, and thereby adjustably sustain the rollers against end pressure of the spindle b, said screws being provided with heads e' e' on their outer ends by which to turn the same, and thus adjust the blocks e e, so as take up the wear on the rollers and spindle and cause the rollers to properly bear on the end of the spindle. Said screws are provided with jam-nuts f' f', which bear against the exterior of the casing C, by which said screws are held in their adjusted position. Said casing is preferably provided with a lubricator g' in its top in proximity to the rollers g g.

The spindle b is provided with a removable end section h, by which it bears against said rollers, said section being held in a socket h', formed in the end of said spindle, as clearly shown in Fig. 2 of the drawings.

The aforesaid rollers g g are provided with a side play on the shaft f, and being pivoted independent of each other, as aforesaid, and bearing on the end of the spindle on opposite sides of its center they revolve in opposite directions.

I do not limit myself to the employment of my improved antifriiction-bearing in connection with the spindle of a metal-spinning lathe or analogous lathes, as the same may be used in connection with a revoluble spindle or shaft in machines of various kinds, and may be used in connection with car-axles by mere modifications.

What I claim is—

The combination with the lathe-spindle b and head-stock B, of the casing C attached to said head-stock and provided with the longitudinal guides d d, the blocks e e seated movably in said guides, the shaft f extending diametrically across said casing and attached to

the aforesaid blocks, the rollers *g g* journaled
on said shaft and bearing on the end of the
spindle, and the set-screws *cc* passing through
the rear end of said casing in lines parallel to
5 the axis of the spindle and bearing on the
rear of the aforesaid blocks substantially as
set forth and shown,

In testimony whereof I have hereunto
signed my name this 2d day of August, 1895.

JOHN J. HURLEY. [L. S.]

Witnesses:

JOHN J. LAASS,
BURT HURLEY.