

March 2, 1943.

A. CALDWELL ET AL
ELASTIC FLUID GENERATOR

2,312,876

Filed Jan. 23, 1942

Fig. 1.

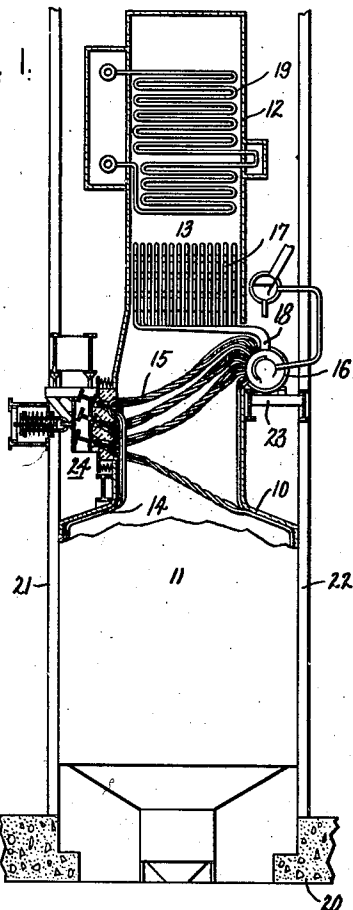
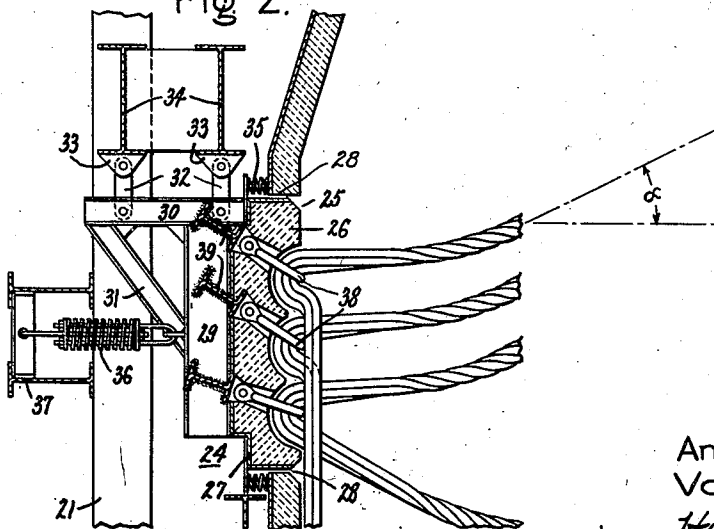

Fig. 2.



Inventors:
Andrew Caldwell,
Vorras A. Elliott,
by *Harry E. Dunham*
Their Attorney.

UNITED STATES PATENT OFFICE

2,312,876

ELASTIC FLUID GENERATOR

Andrew Caldwell, Ballston Lake, and Vorras A. Elliott, Schenectady, N. Y., assignors to General Electric Company, a corporation of New York

Application January 23, 1942, Serial No. 427,960

6 Claims. (Cl. 122-235)

The present invention relates to elastic fluid generators in which an operating medium is heated in a plurality of tubes and discharged therefrom into a drum or liquid vapor separating vessel. More specifically the invention relates to supporting arrangements for boiler tubes which are suspended as catenaries. The invention is of particular importance in connection with mercury boilers operated at high temperatures.

The object of our invention is to provide an improved construction and arrangement of tube supports whereby stresses in the tubes and the elements connected thereto are reduced to a minimum.

For a consideration of what we believe to be novel and our invention, attention is directed to the following description and the claims appended thereto in connection with the accompanying drawing.

In the drawing Fig. 1 illustrates a mercury boiler partly in section in accordance with our invention; and Fig. 2 is an enlarged detail view of a part of Fig. 1.

The mercury boiler illustrated in the drawing has lower walls 10 forming a combustion chamber 11 and upper walls 12 forming a convection chamber for receiving combustion gases discharged from the chamber 11. The walls 10 of the combustion chamber are lined with a plurality of substantially vertically arranged heating tubes 14. Upper portions of at least some of the heating tubes 14 are arranged in groups or bundles 15 which are twisted and extended across the lower portions of the convection space with their ends connected to the side wall of a vessel or mercury liquid separating device 16. The vessel or drum 16 in the present arrangement is located outside the right-hand wall of the convection space.

The groups or bundles of tubes or tube portions 15 form slag screens to reduce the discharge of slag from the combustion chamber into the convection chamber and a stack connected to the latter. Banks of mercury heating tubes 17 are located in the lower portion of the convection space and have discharged ends 18 connected to the top of the drum 16. Ordinarily the inlets of the tubes 17 are connected to the outlets of some of the heating tubes in the combustion chamber 11. A steam superheater 19 is disposed in an upper portion of the convection chamber 13 to utilize available heat energy from the gases discharged from the lower portion of the combustion chamber. A mercury boiler of this type is more fully disclosed in the patent to B. P. Coulson, Jr. 2,202,835, issued June 4, 1940, and assigned to the same assignee as the present application.

The boiler is supported on a foundation 20 and

a plurality of spaced pillars or beams of structural iron 21, 22. The drum 16 is held on the pillars 22 by means including horizontal beams 23.

An important feature of our invention is the arrangement for supporting the groups of tubes 15 which, as stated above, are suspended as catenaries. The right-hand ends of the tubes are fused to openings in the side wall of the drum 16. Thus the drum 16 and its supporting means 22, 23 constitute a substantially rigid support for the discharge ends of the tubes 15. The left-hand portions of the tubes 15 are flexibly or yieldingly held on a supporting arrangement 24. This supporting arrangement includes a wall portion 25 (Fig. 2) made of heat-insulating material 26 covered on its outside by a metal cover or enclosure 27. The wall portion 25 is movably independent on the other portions of the wall 12 and suitably sealed thereto to reduce the discharge of gases from the convection chamber through clearances 28 formed between the wall portion 25 and the other portions of the walls 12. The wall portion 25 is attached to a structure including vertical beams 29 and horizontal beams 30 rigidly secured together by means of slanted structural irons 31. Thus the wall portion 27 with the beams and irons 29, 30, 31 form a rigid structure. This structure is vertically supported by means of a plurality of links 32 having lower ends pivotally connected to the beam 30 and upper ends pivotally held on ears 33 of horizontal beams or rigid supporting elements 34. The wall 27 is biased horizontally outward by means including compression springs 35 held between extensions of the cover 27 and adjacent portions of the stationary walls 12. In addition the wall 26 is biased outward, that is, away from the convection chamber by another compression spring means 36 which has ends suitably linked to the vertical beam 29 and to a supporting structure 37 held on the beams 21.

The left-hand end portions of the groups of tubes 15 are held on links 38 which latter are pivotally supported on irons 39 fastened to the beams 29 and 30. Each tube or groups of tubes forms a catenary and as such exerts horizontal and vertical forces on its supports. Each portion of the tubes themselves is subjected to such forces. The left-hand parts of the tubes are substantially straight and inclined towards the horizontal by an angle alpha. It is desirable to maintain this angle alpha substantially constant because for a certain angle alpha a minimum turning moment is exerted by the tubes on the drum or, from another viewpoint, in order to maintain at a minimum the turning moment exerted by intermediate portions of the tubes on their end portions fused to the drum. The angle alpha is a measure of the sag of the tube, that is, the vertical distance between their upper

ends connected to the drum located at a higher level and their lower portions connected to the flexible support described above and located at a lower level. In accordance with our invention the tubes are connected to a support which biases the tubes horizontally with a force responsive to changes in sag, which increases with rising temperature, causing expansion of the tubes. This is accomplished by the flexible supporting means including the springs 35 and 36 described above. The horizontal force F exerted on a support by a catenary structure is equal to $F = WO^2/8A$ in which W is the weight per foot of the structure, O is the span of the catenary and A is the sag. Thus, this horizontal force is inversely proportional to the sag. An increase in temperature during operation of the boiler causes an increase in sag of the tubes and accordingly a decrease of the horizontal force F . As this force F is equal to or balanced by the force of the springs 35, 36 such springs force the catenary tubes outward, that is, towards the left in the drawing as the sag increases. This outward movement during operation continues until the supporting force exerted by the springs balances the horizontal force exerted by the tubes, resulting in the maintenance of a substantially constant catenary shape with changes of temperature and consequently in a constant turning moment exerted on the discharge portions of the tubes.

Similarly, a decrease in temperature causing contraction of the tubes and a reduced sag effects an increase in the horizontal force F of the tubes. This increased force F is balanced by increased compression of the springs 35 and 36 whereby the wall portion 25 is moved inward, that is, towards the convection chamber until the two forces balance and the tubes 15 assume their original catenary shape.

Thus, with our invention we have accomplished an improved construction and arrangement for supporting boiler heating tubes arranged to form catenaries and subject to varying temperatures during operation. In a preferred embodiment of our invention, as described above, one end of each tube is rigidly connected to a rigid support and another end portion of each tube is connected to a yieldable support. The latter is biased horizontally by means forcing the tube or tubes outward, that is, away from the heating chamber, with a force varying in response to changes of the tube temperature or the sag of the tube. The horizontal biasing means in the example described above is in the form of a plurality of springs connecting a movable wall portion of the boiler for holding the tubes to a rigid support.

Having described the method of operation of our invention, together with the apparatus which we now consider to represent the best embodiment thereof, we desire to have it understood that the apparatus shown is only illustrative and that the invention may be carried out by other means.

What we claim as new and desire to secure by Letters Patent of the United States is:

1. A boiler comprising a wall forming a heating chamber, a heating tube in the chamber forming a catenary, a support secured to the wall for rigidly supporting one end of the tube,

and means for supporting the other end of the tube, said means including a horizontally movable member to maintain the sag of the tube substantially constant.

2. A boiler comprising a wall forming a heating chamber, a tube for heating operating medium extending across the chamber and having the shape of a catenary, means rigidly supporting one end of the tube, and means yieldingly supporting another portion of the tube and exerting a horizontal force thereon varying in response to changes in sag of the tube in order to maintain the sag of the tube substantially constant.

3. A boiler comprising a wall forming a heating chamber, a tube having a catenary shape in the chamber for receiving operating medium to be heated, a rigid support connected to one end of the tube, and means including a spring for supporting the other end of the tube to maintain the catenary shape of the tube substantially constant with changes in temperature.

4. A boiler comprising a wall forming a heating chamber, a liquid vapor separating drum, a plurality of heating tubes having portions lining the wall of the chamber and other portions with a catenary shape extending across the chamber and having discharge ends rigidly secured to the drum, and a supporting structure for the catenary shaped tube portions, said structure including means for exerting a horizontal force on the tubes varying in response to changes in temperature of the tubes to maintain the catenary shape of the other portions substantially constant.

5. A boiler comprising a wall forming a heating chamber, a drum, a plurality of tubes having portions lining the wall in the chamber and other portions shaped as catenaries and extending across the chamber to form slag screens, the other portions having discharge ends rigidly connected to the drum, and a supporting structure for said other tube portions to prevent changes of their catenary shape upon changes of temperature, said supporting structure including a wall portion of the boiler connected to said other tube portions and means biasing the wall portion horizontally with a force varying in response to changes in sag of the other tube portions.

6. A boiler comprising a wall forming a heating chamber, a drum, a plurality of tubes having portions lining the wall in the chamber and other portions shaped as catenaries and extending across the chamber to form slag screens, the other portions having discharge ends rigidly connected to the drum, and a supporting structure for the other tube portions to prevent changes of their catenary shape upon changes of temperature of the tubes, said supporting structure comprising a wall portion horizontally movable independent of the remaining wall of the boiler and linked to the other tube portions, beams secured to and reinforcing said wall portion, means including links vertically supporting the beams and permitting horizontal movement thereof, and means including a spring connected to the beams and biasing the wall portion horizontally against the horizontal force created by the catenary shape of the other tube portions.

ANDREW CALDWELL.
VORRAS A. ELLIOTT.